

- | | | | |
|-----------|-----------------------------|-----------|-------------------------|
| D | Montageanleitung | GB | Assembly instructions |
| FR | Notice de montage | IT | Istruzioni di montaggio |
| NL | Handleiding voor de montage | PL | Instrukcja montażu |
| CZ | Montážní návod | SK | Návod na montáž |
| HU | Szerelési útmutató | RO | Instructiuni de montaj |
| TR | Montaj talimatı | RU | инструкция по монтажу |

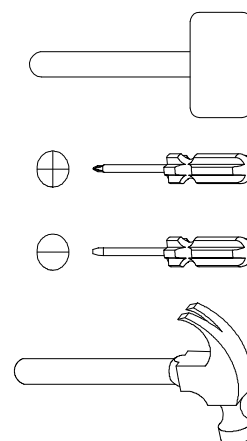

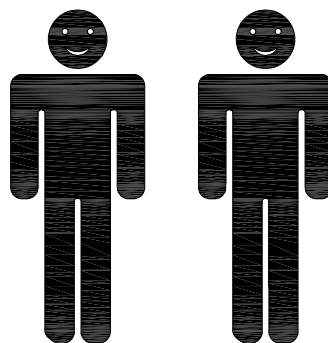







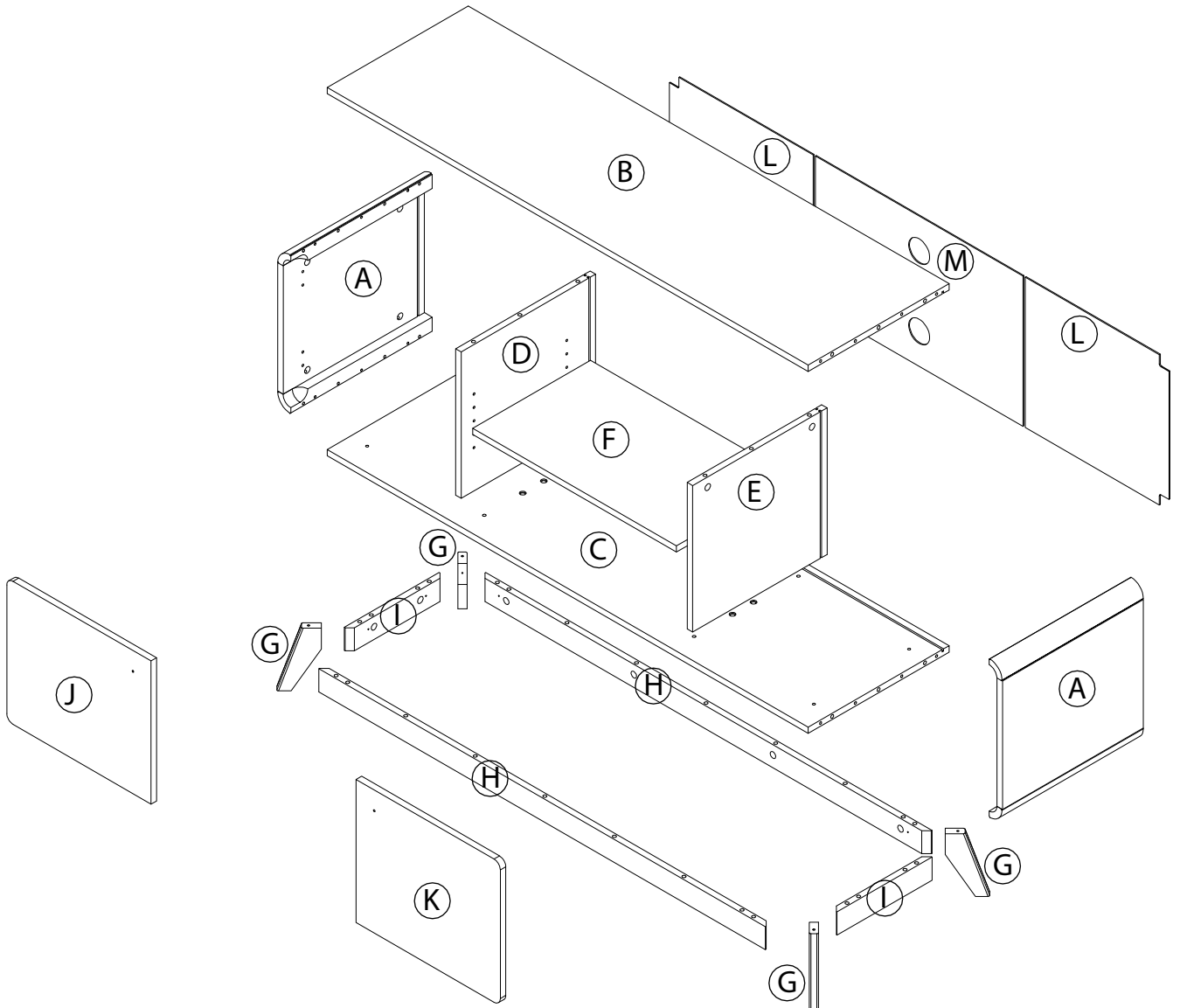
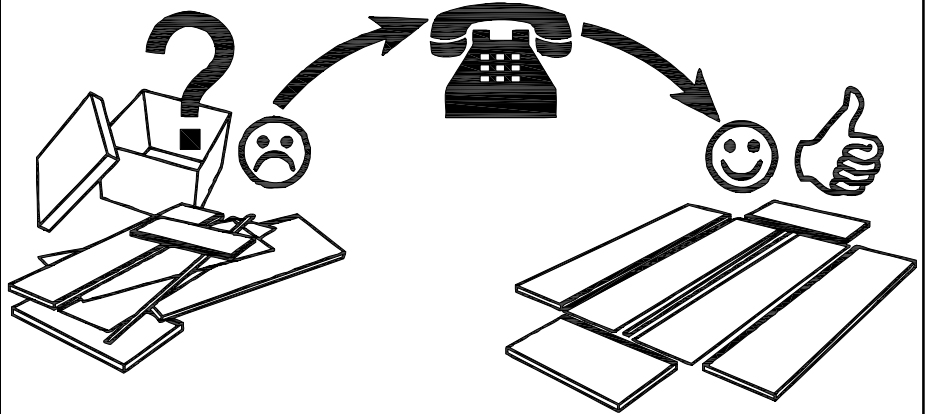
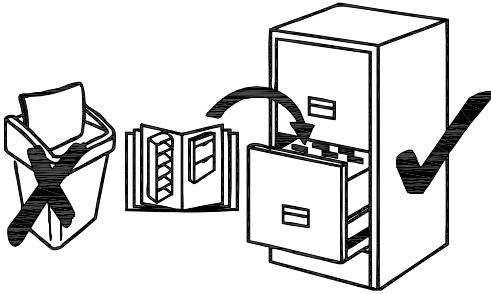

Service • Assistenza • Dienstverlening • Serwis Servis • Szerviz • Сервисная служба



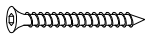



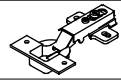

Name • Nom • Nome • Naam •
Nazwa • Jméno • Názov • Név •
Denimire • Isim • Название

Nr. • No. • N° • Номер • Č • Sz

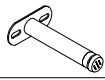
Typ • Type • Tip • Típus • Tipo •
Тип



1		CSK SCREW M3.5 X 15MM	16
2		SCK SCREW M4 X 25MM	4
3		EURO SCREW M6 X 13MM	8
4		JCBC (W) SCREW M6 X 40MM	8
5		JCBC SCREW M6 X 12MM	4
6		JCN NUT Ø6 X L13MM	4
7		WOOD DOWEL Ø6 X 35MM	16
8		WOOD DOWEL Ø8 X 25MM	16
9		MINIFIX M5 x 29MM	28
10		CAM 15/12	28

11		HINGES 7/8	4
12		PLASTIC LEVELLER 10MM	4
13		WOODEN KNOB HANDLE HANDLE SCREW M4 X 25MM	2 SETS
14		T.SHAPE METAL LEG (ADJUSTABLE)	2
15		TABLE CORNER BRACKET (5 HOLES)	4
16		SHELF SUPPORT	4
17		ALIEN KEY M4	1
18		BACKPLY STOPPER	16
19		GLUE	3
20		CSK SCREW M3.1 X 20MM	16

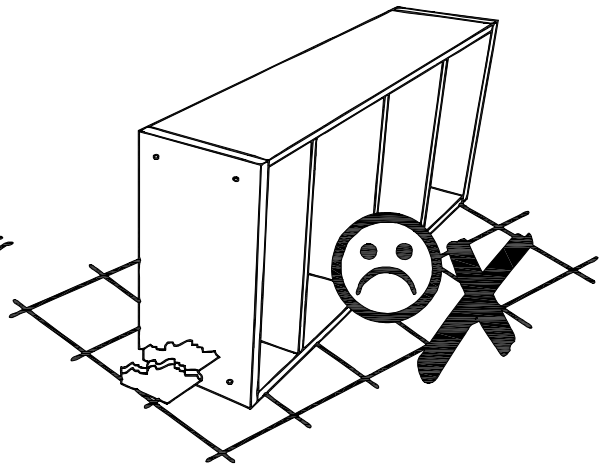
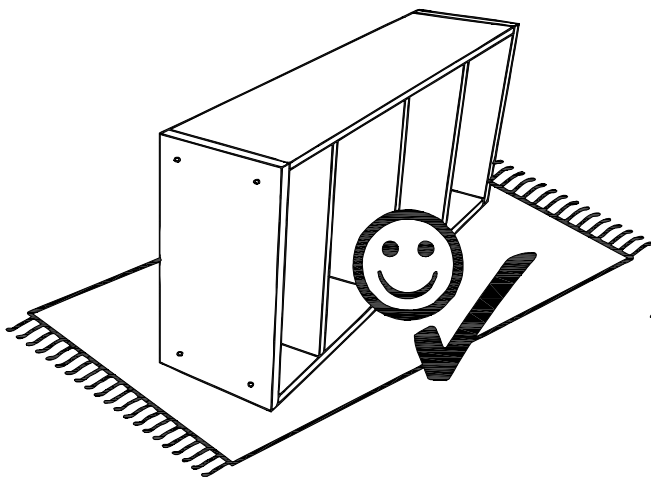

1

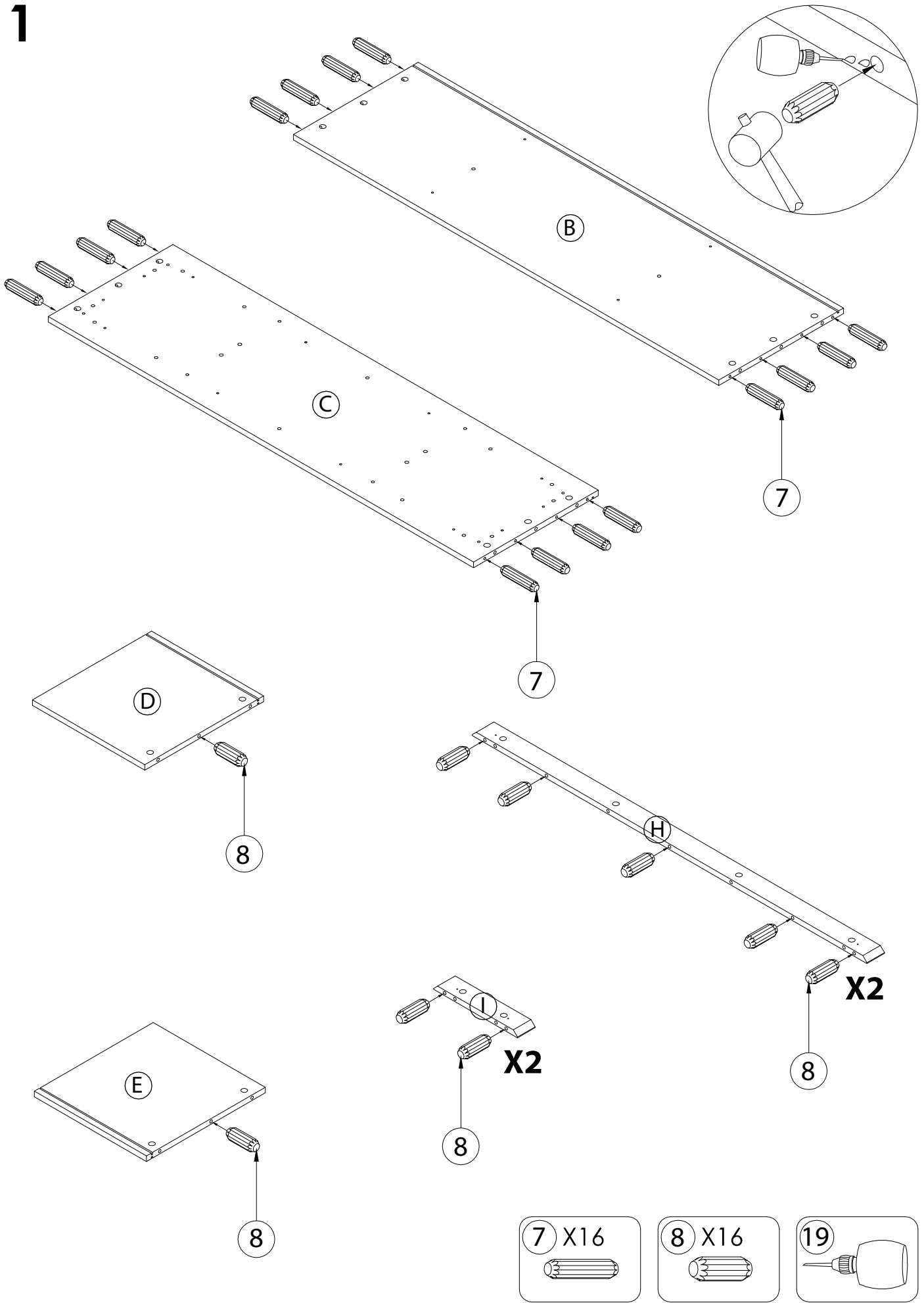

2

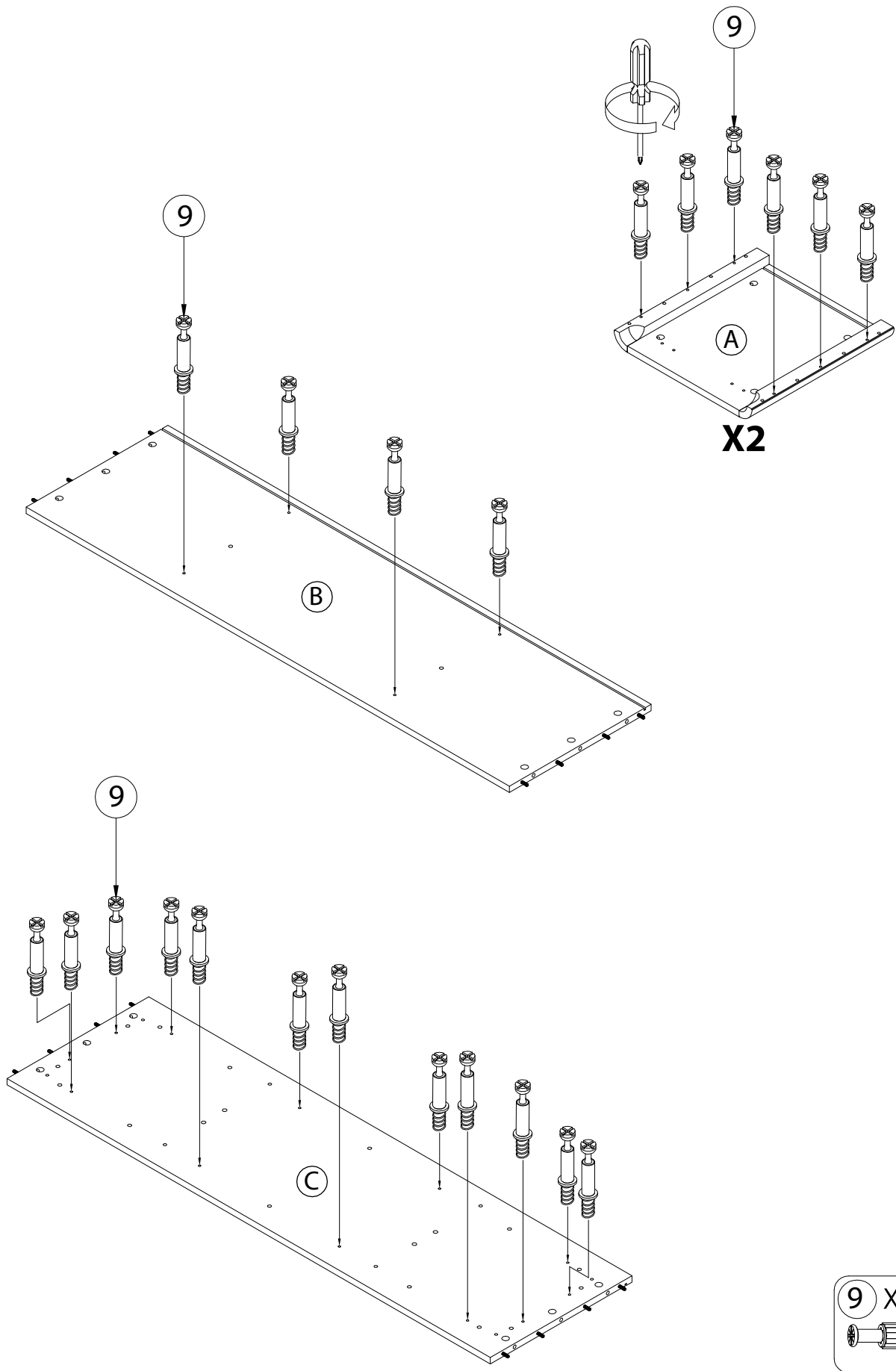

3

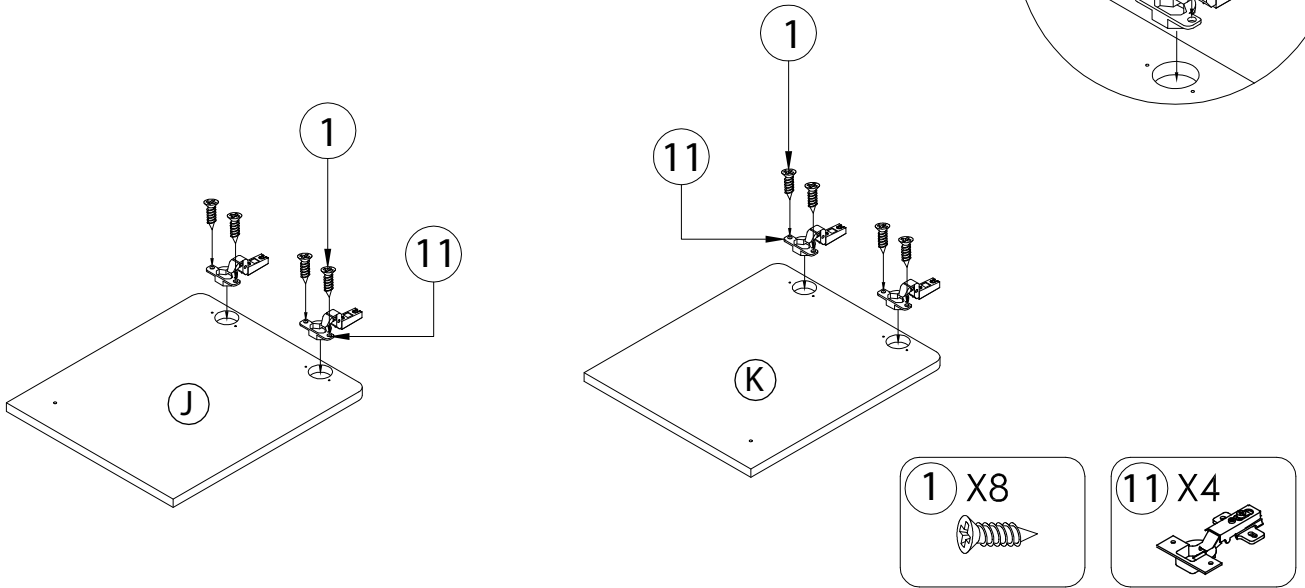

4

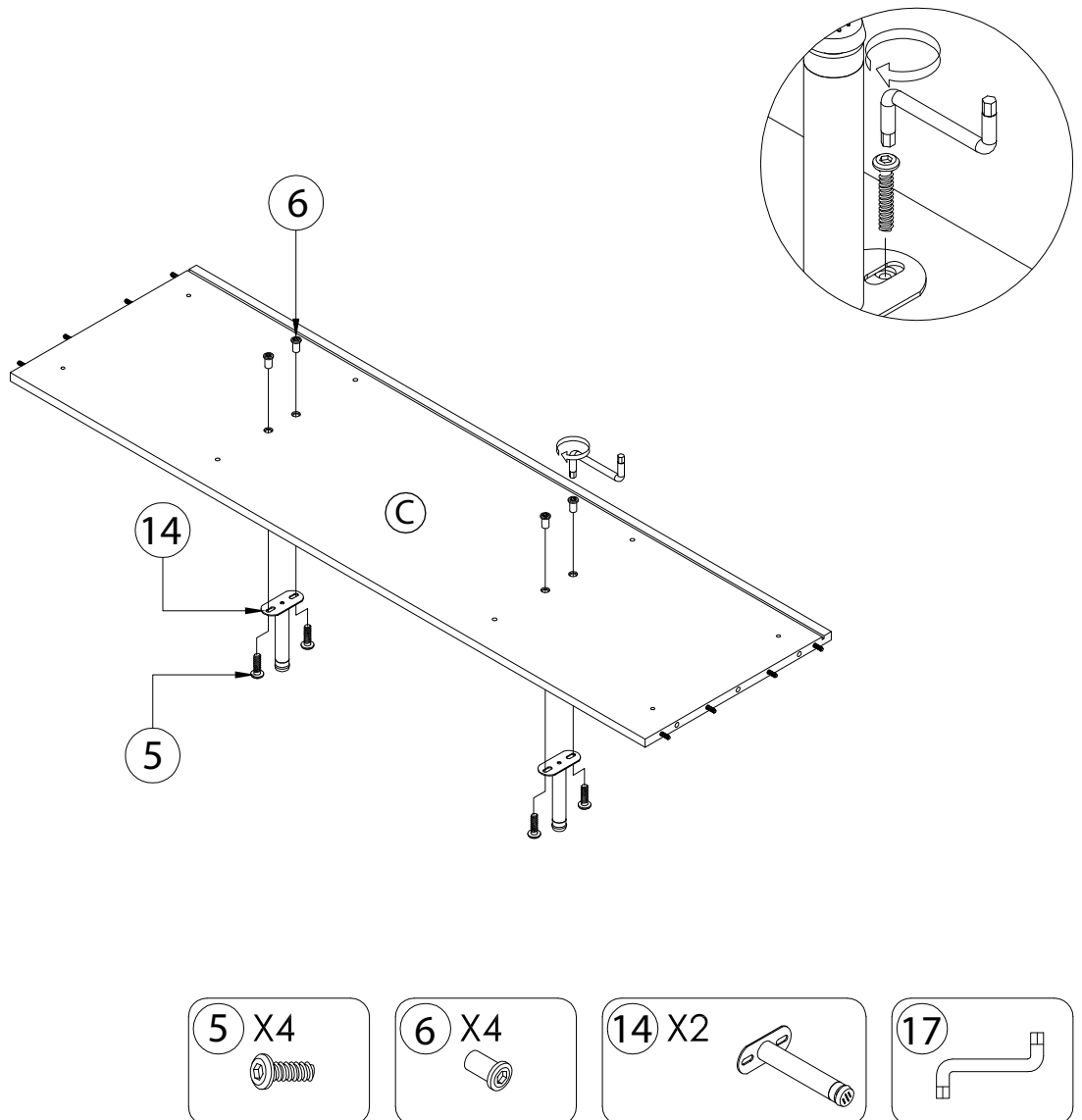

5

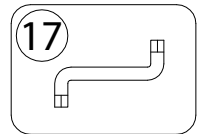
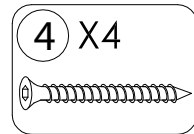
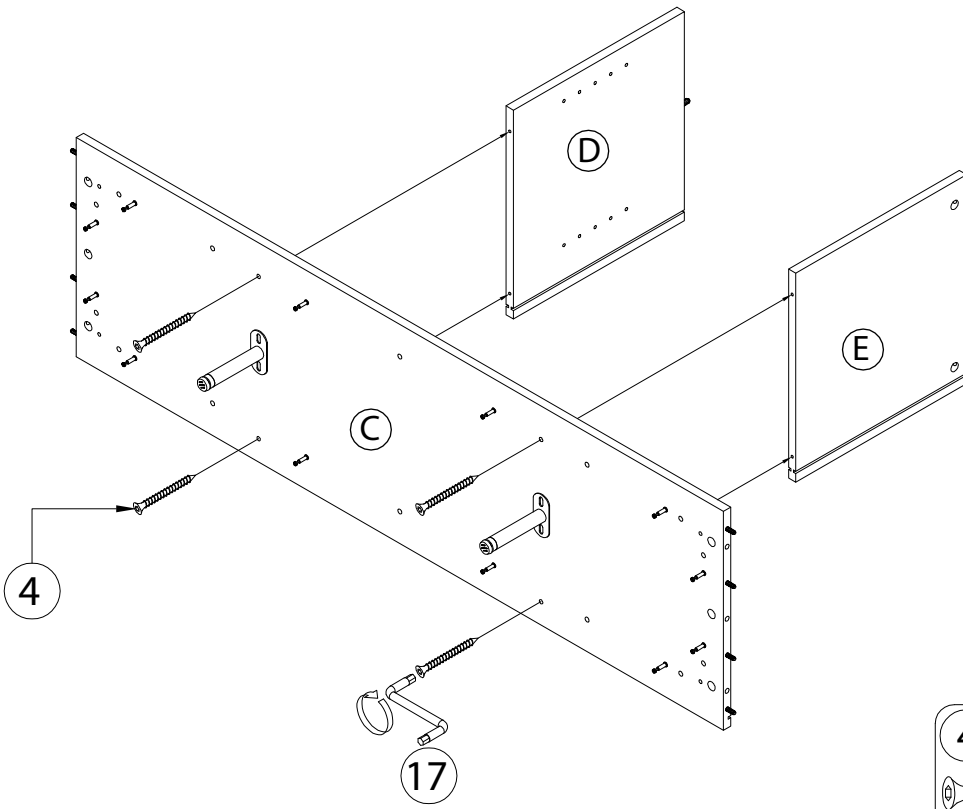

6

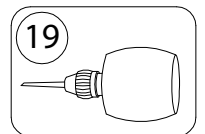
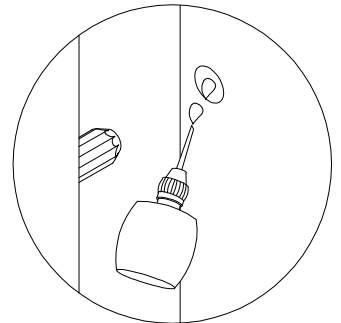
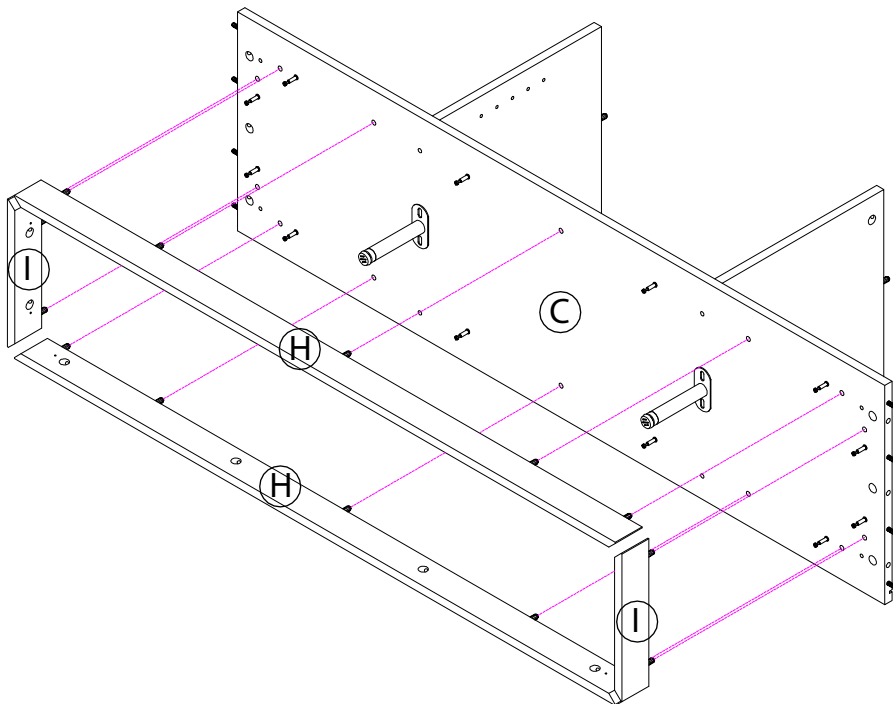

7

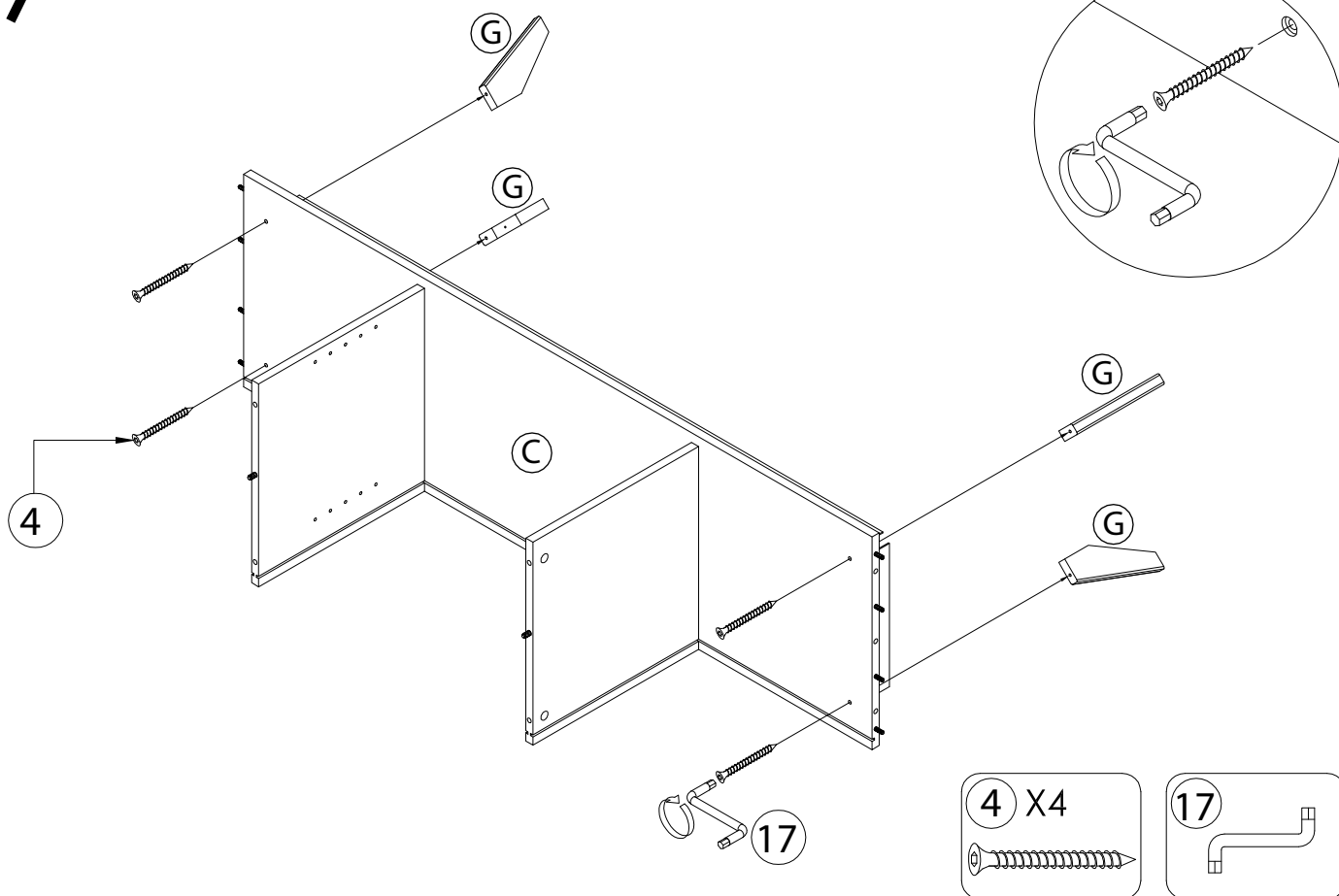

8

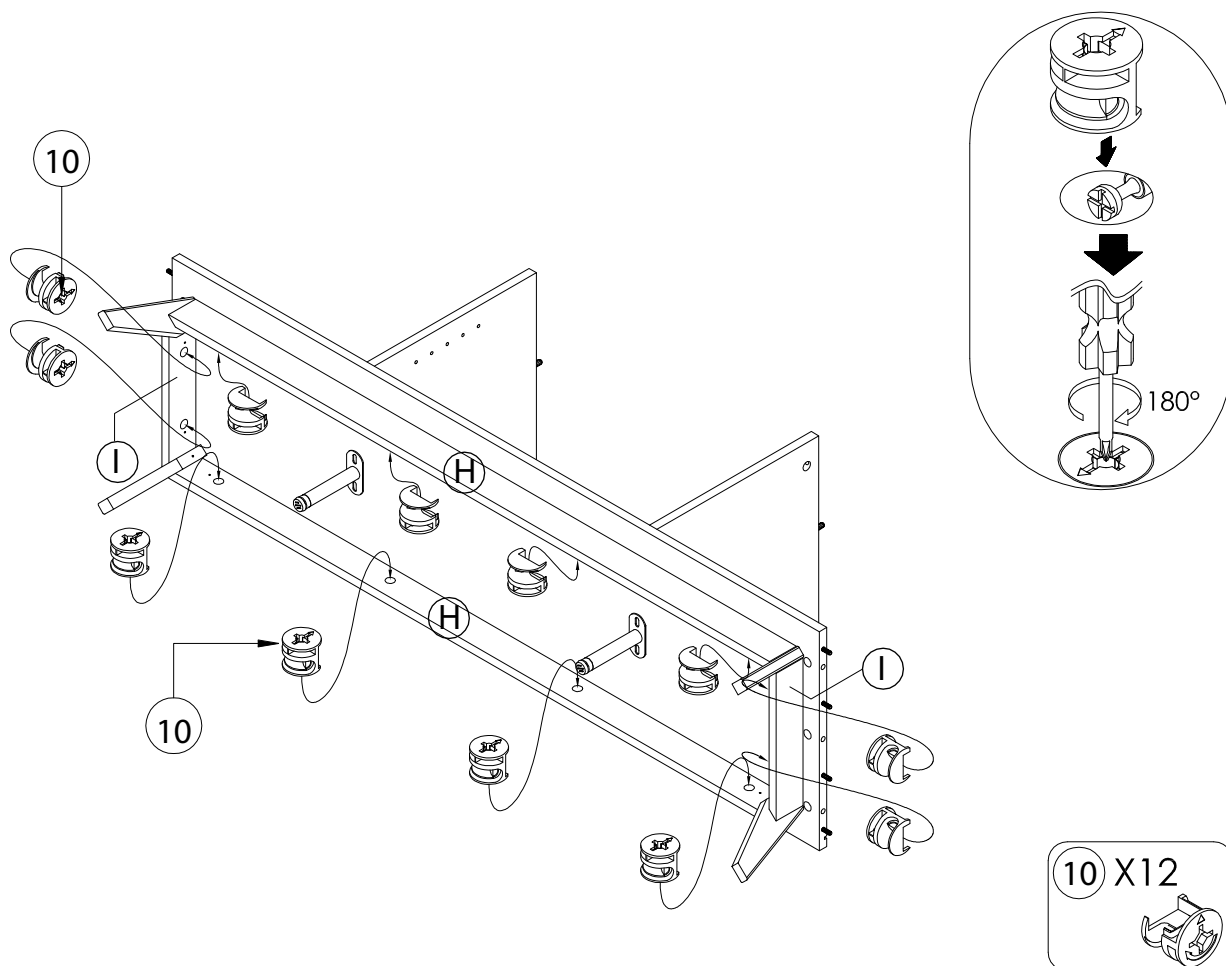

9

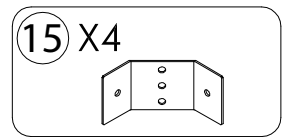
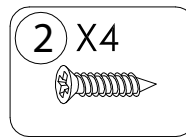
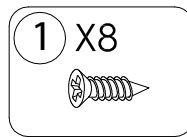
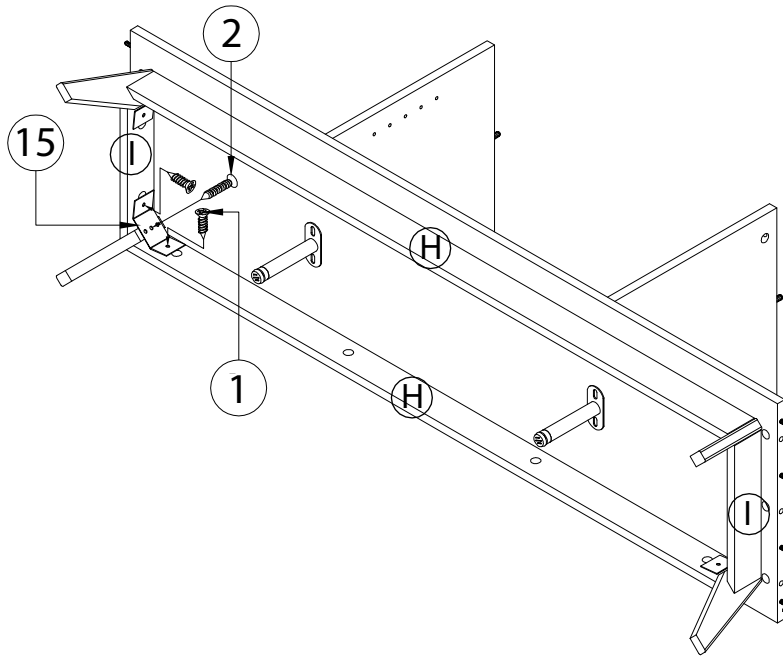

10

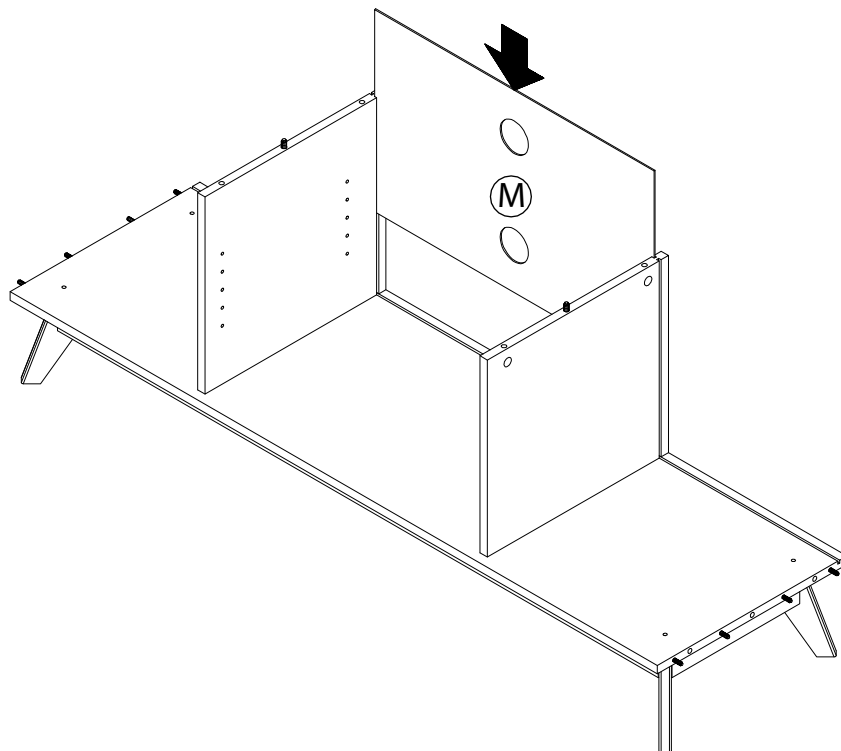

11

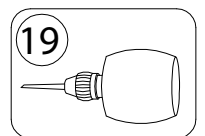
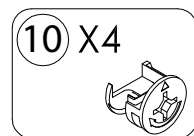
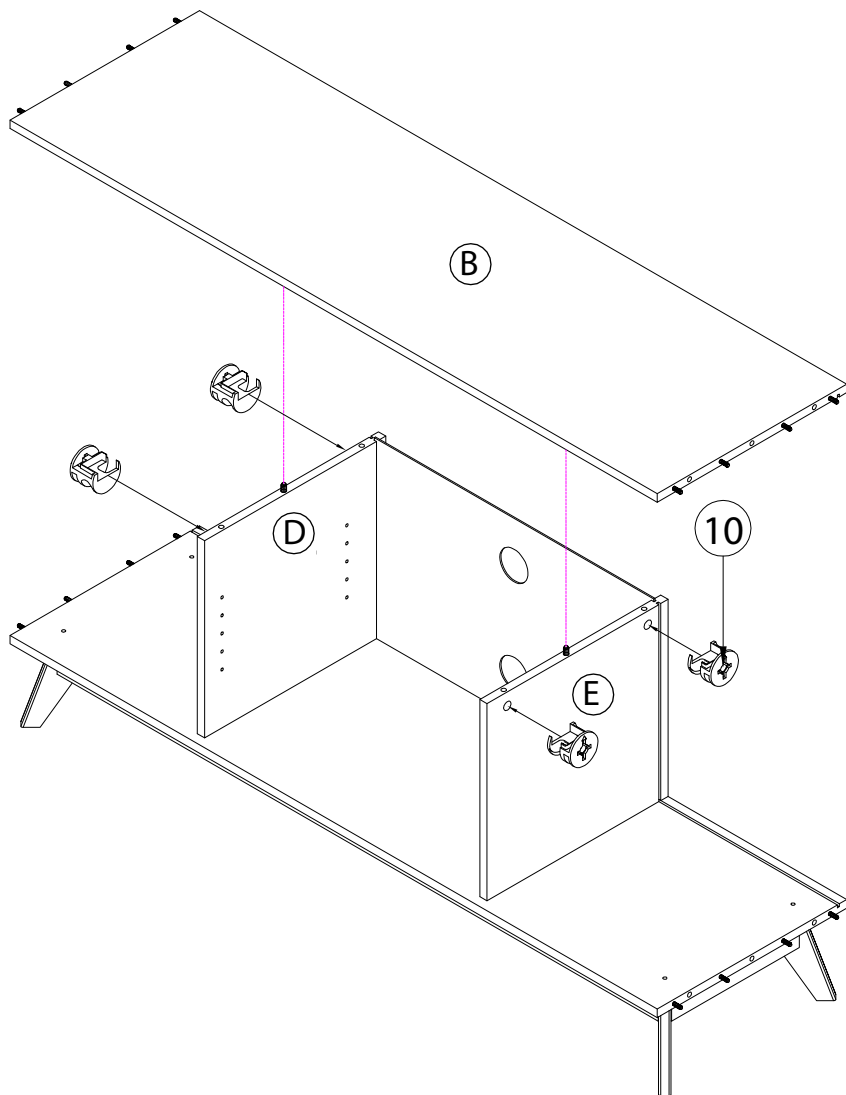
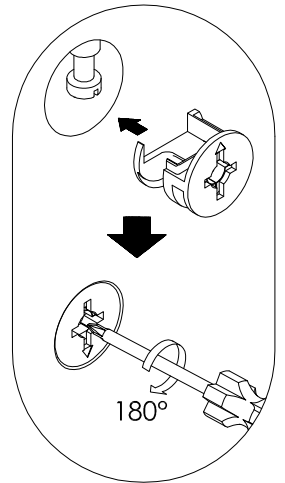
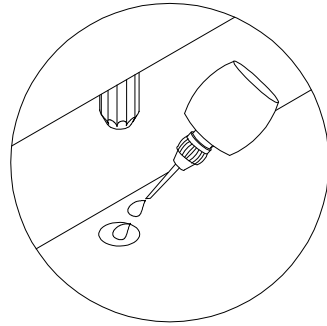

12

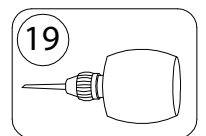
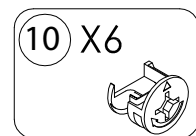
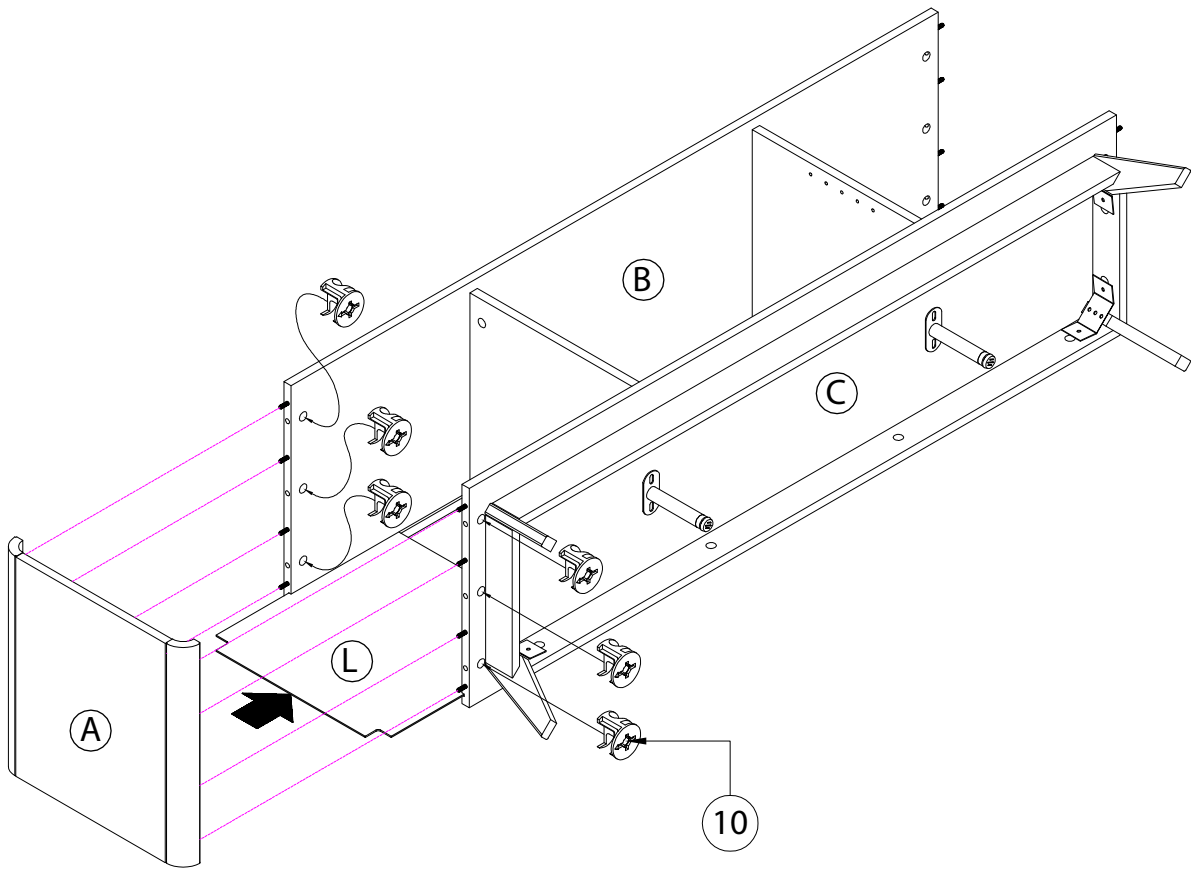
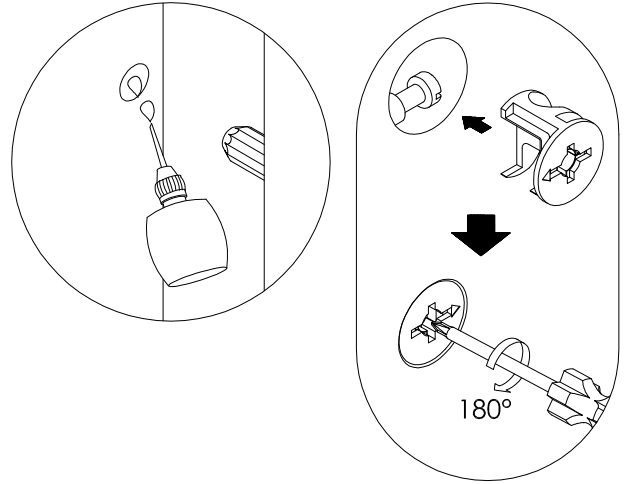

13

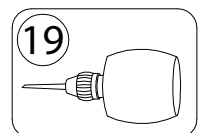
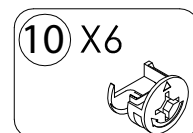
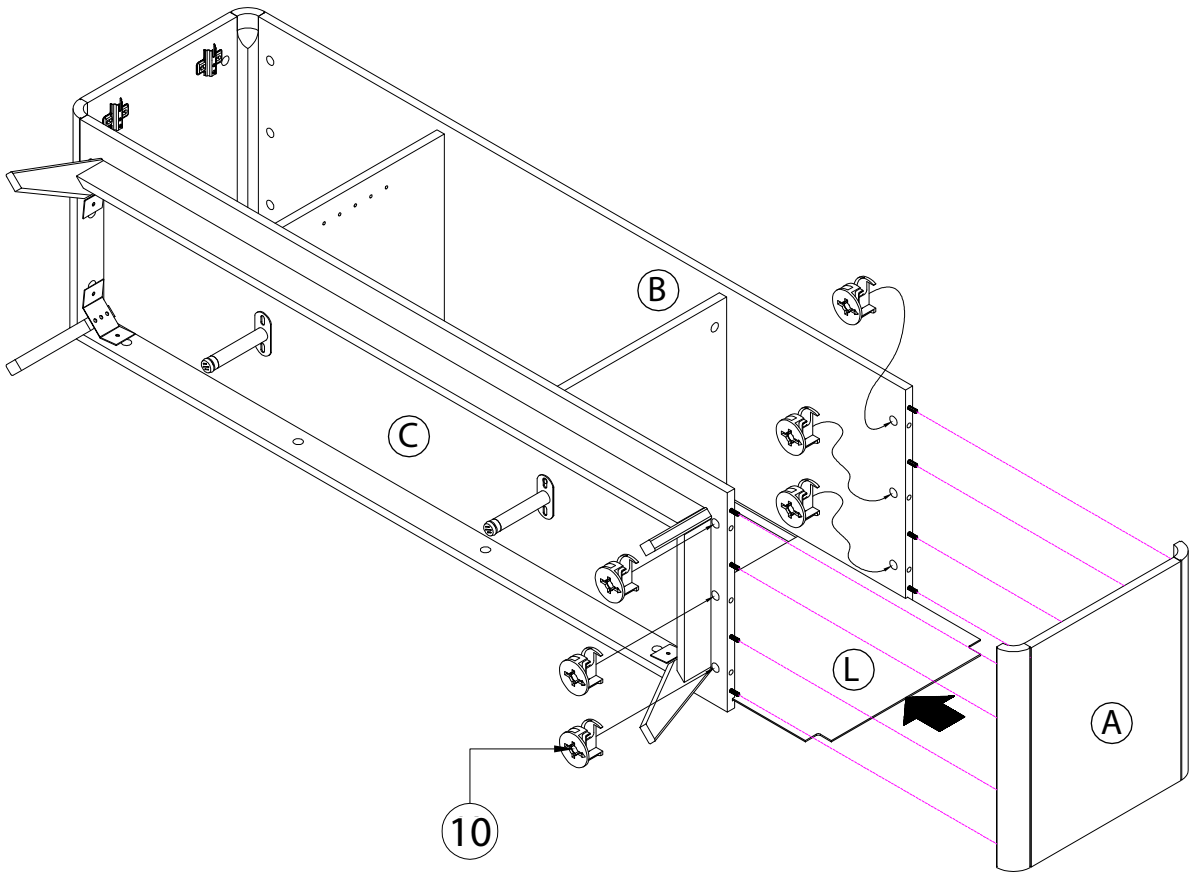
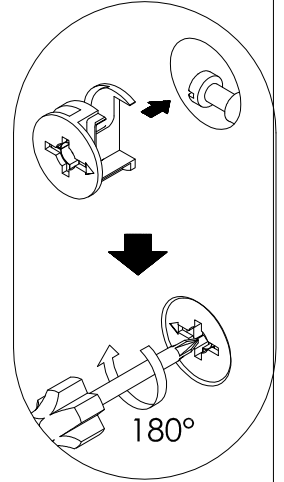
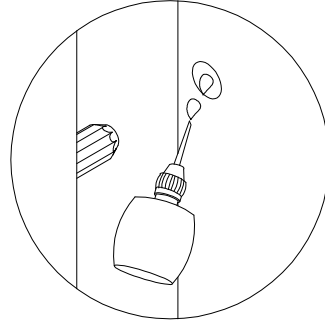

14

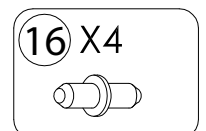
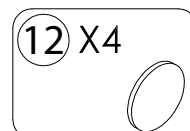
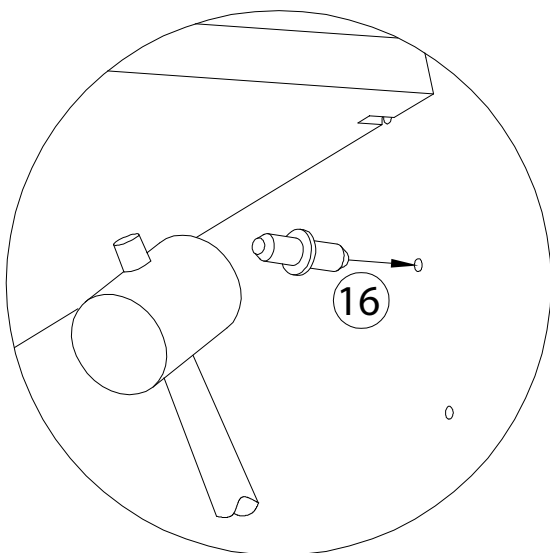
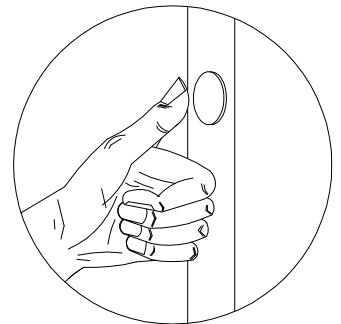
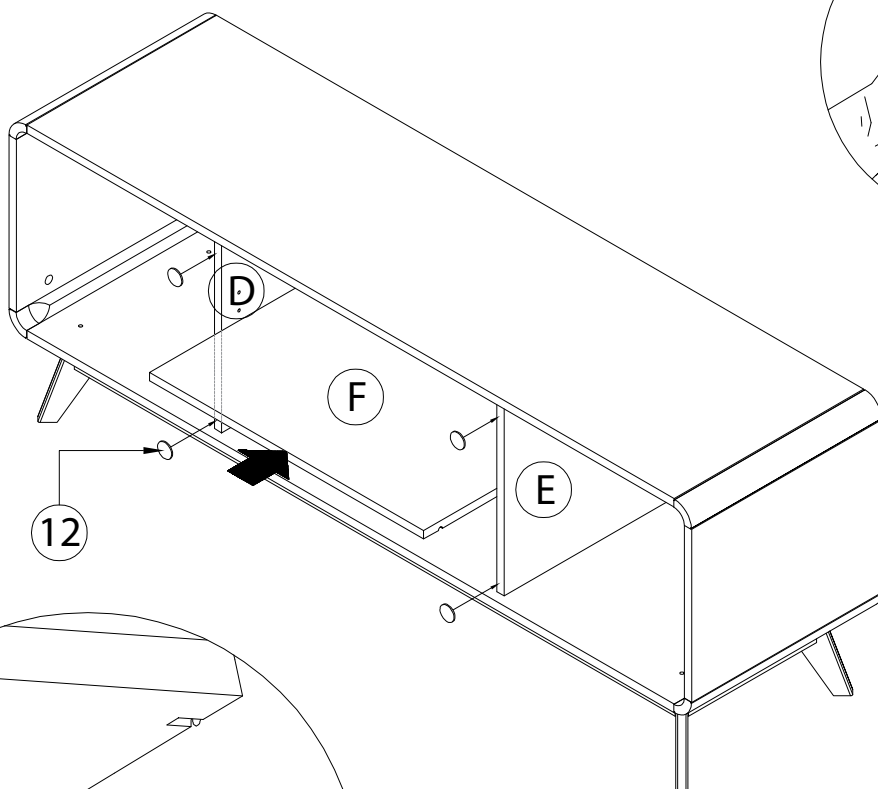



**Achtung • Attention • Attenzione • Opgelet • Uwaga • Pozor • Figyelem • Atenție •
Dikkat • Вниманіе**



(D)	<i>Türen einstellen (Scharniere justieren)</i>
(GB)	<i>Adjusting the doors (adjusting the hinges)</i>
(NL)	<i>Deuren instellen (scharnieren afstellen)</i>
(PL)	<i>Nastawić drzwi (wyrównać zawiasy)</i>
(TR)	<i>Kapıların ayarlanması (menteselerin seviye ayarı)</i>
(RU)	<i>Регулировка дверей (регулировка шарнира)</i>
(FR)	<i>Régler les portes (ajuster les charnières)</i>
(IT)	<i>Sistemare le porte (regolare le cerniere)</i>
(CZ)	<i>Vyrovnejte dvířka (seřďte závěsy)</i>
(SK)	<i>Nastavenie dverí (nastavenie závesov)</i>
(HU)	<i>Állítsa be az ajtókat (állítsa be a zsanérokat)</i>
(RO)	<i>Reglare ușii (ajustare balamale)</i>

15

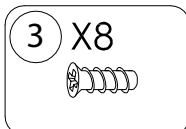
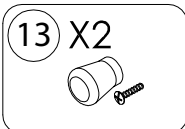
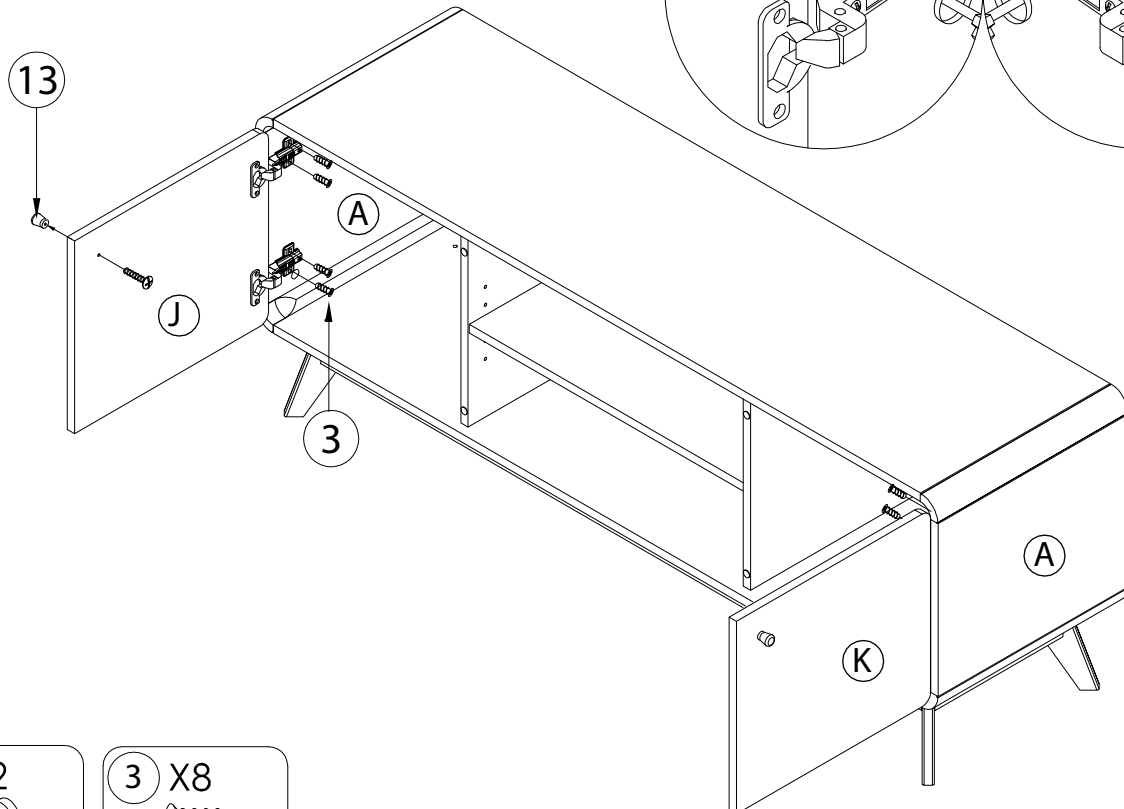
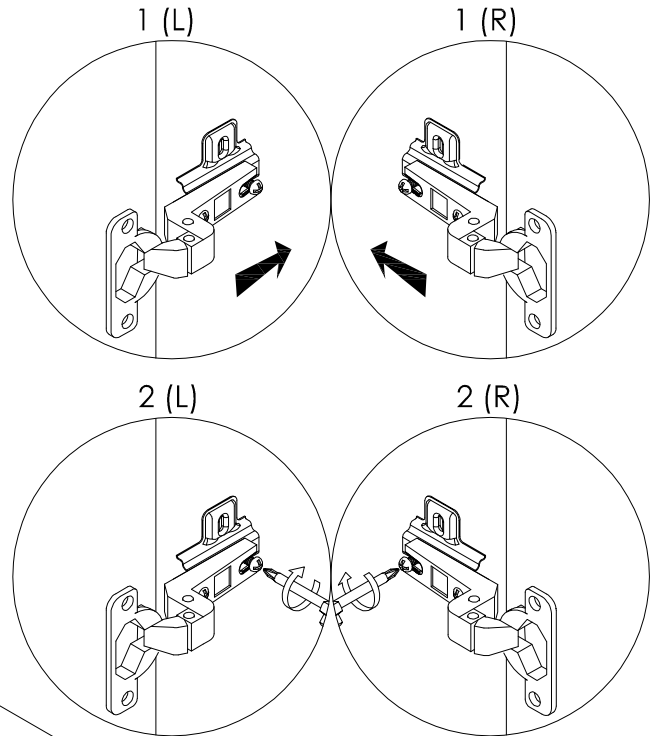
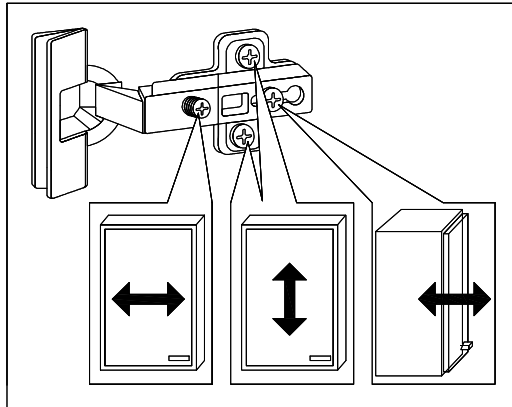

16

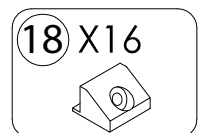
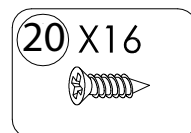
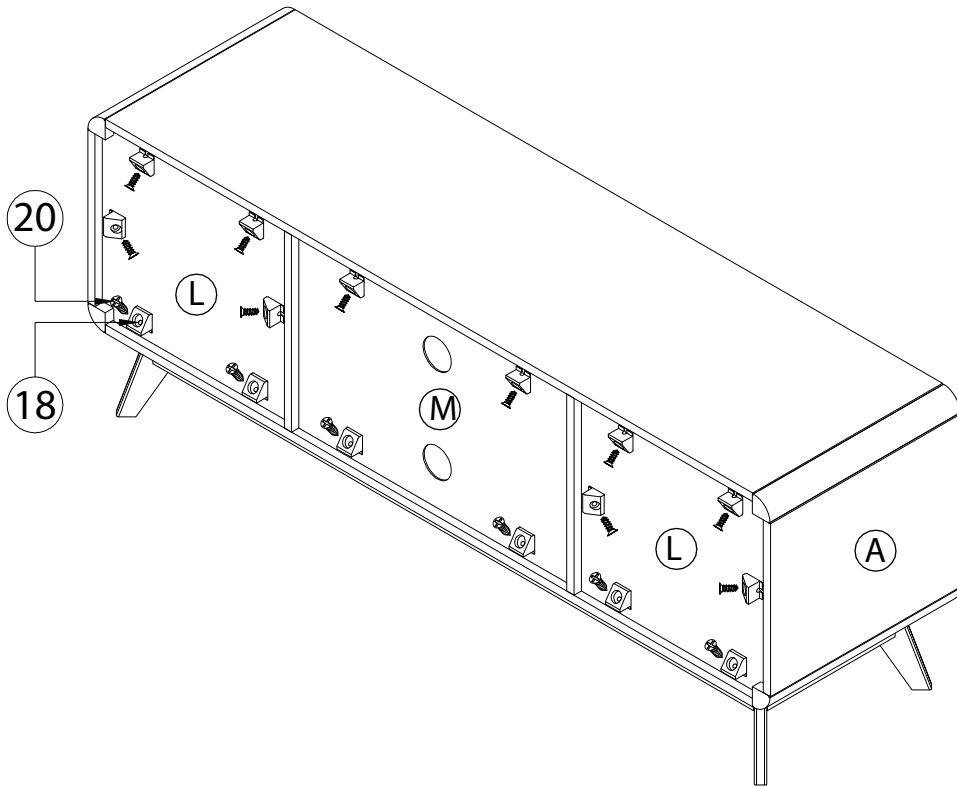
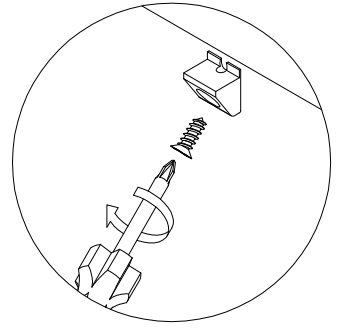

D	Bitte nur mit einem Staubtuch oder leicht feuchtem Lappen reinigen. Keine scheuernden Putzmittel verwenden.
GB	Please only clean with a duster or a damp cloth. Do not use any abrasive cleaners.
FR	Veuillez nettoyer uniquement avec un chiffon à poussière ou un chiffon légèrement humide. Ne pas utiliser de détergent abrasif.
IT	Si raccomanda di pulire solo con un panno per la polvere o uno strofinaccio umido. Non utilizzare detersivi abrasivi.
NL	Reinig alleen met een stofdoek of een lichtjes vochtige doek. Gebruik geen schurende poetsmiddelen.
PL	Czyszczenie należy wykonać wyłącznie za pomocą ściereczki lub lekko nawilżonego ręcznika. Nie stosować środków czyszczących do szorowania.
CZ	Čistěte prosím jen prachovkou nebo lehce navlhčeným hadrem. Nepoužívejte drhňoucí čisticí prostředky.
SK	Na čistenie používajte len prachovku alebo z ľahka navlhčenú utierku. Nepoužívajte žiadne drhňúce čistiace prostriedky.
HU	Kérjük, csak portörli ő kendővel vagy enyhén nedves ronggyal tisztítsa. Ne használjon dörzshatású tisztítószert.
RO	Vă rugăm să utilizați la curățare exclusiv o cârpă de șters praful sau o cârpă ă ușor umezită. Nu utilizați substanțe de curățat abrazive.
TR	Lütfen sadece bir toz beziyle veya hafif nemli yumuşak bir bezle siliniz. A şındırıcı temizlik malzemeleri kullanmayınız.
RU	Очищайте от пыли тряпкой или слегка влажной ветошью. Не допускается применение чистящих средств, не предназначенных для ухода за мебелью.