

“10”

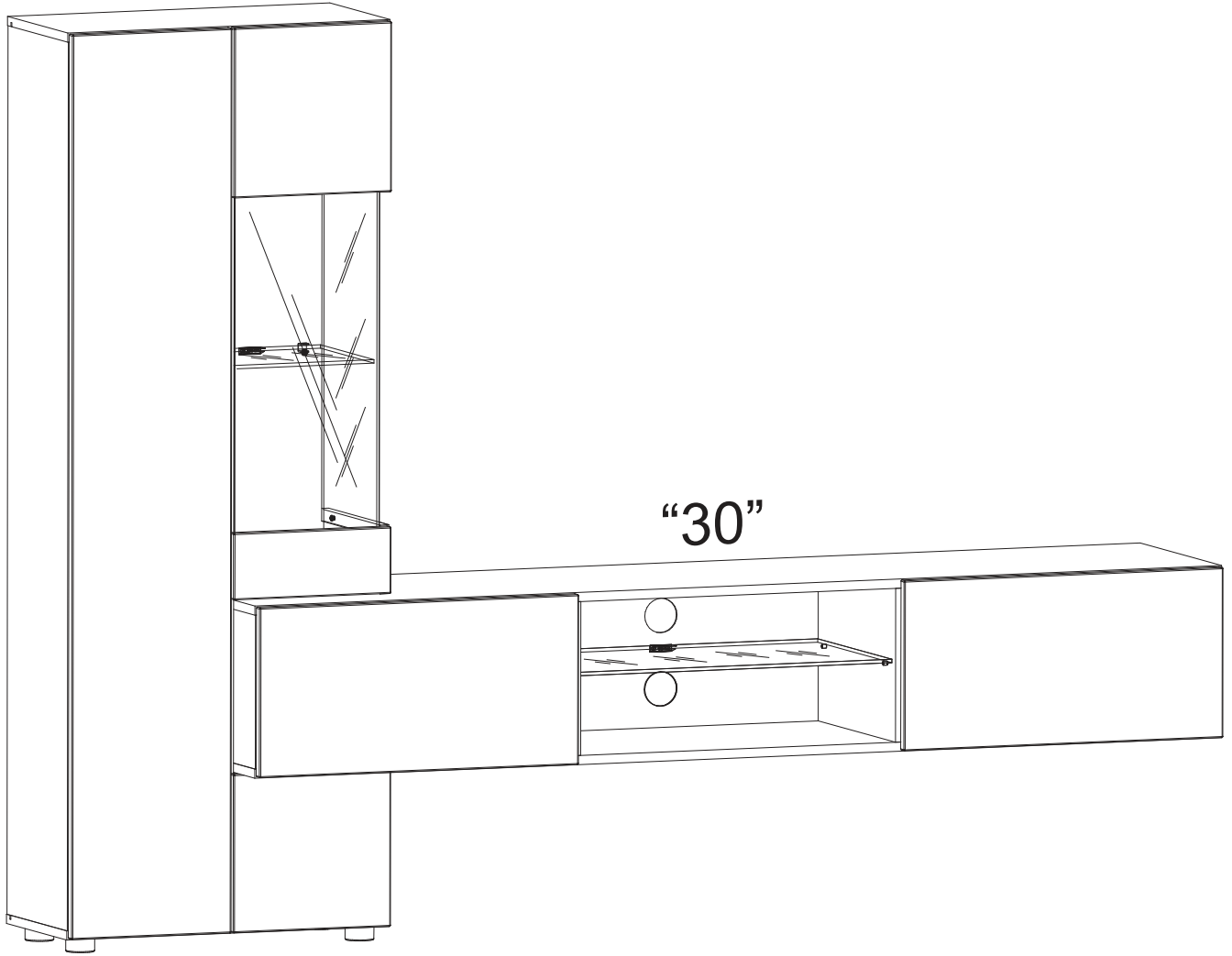

“30”

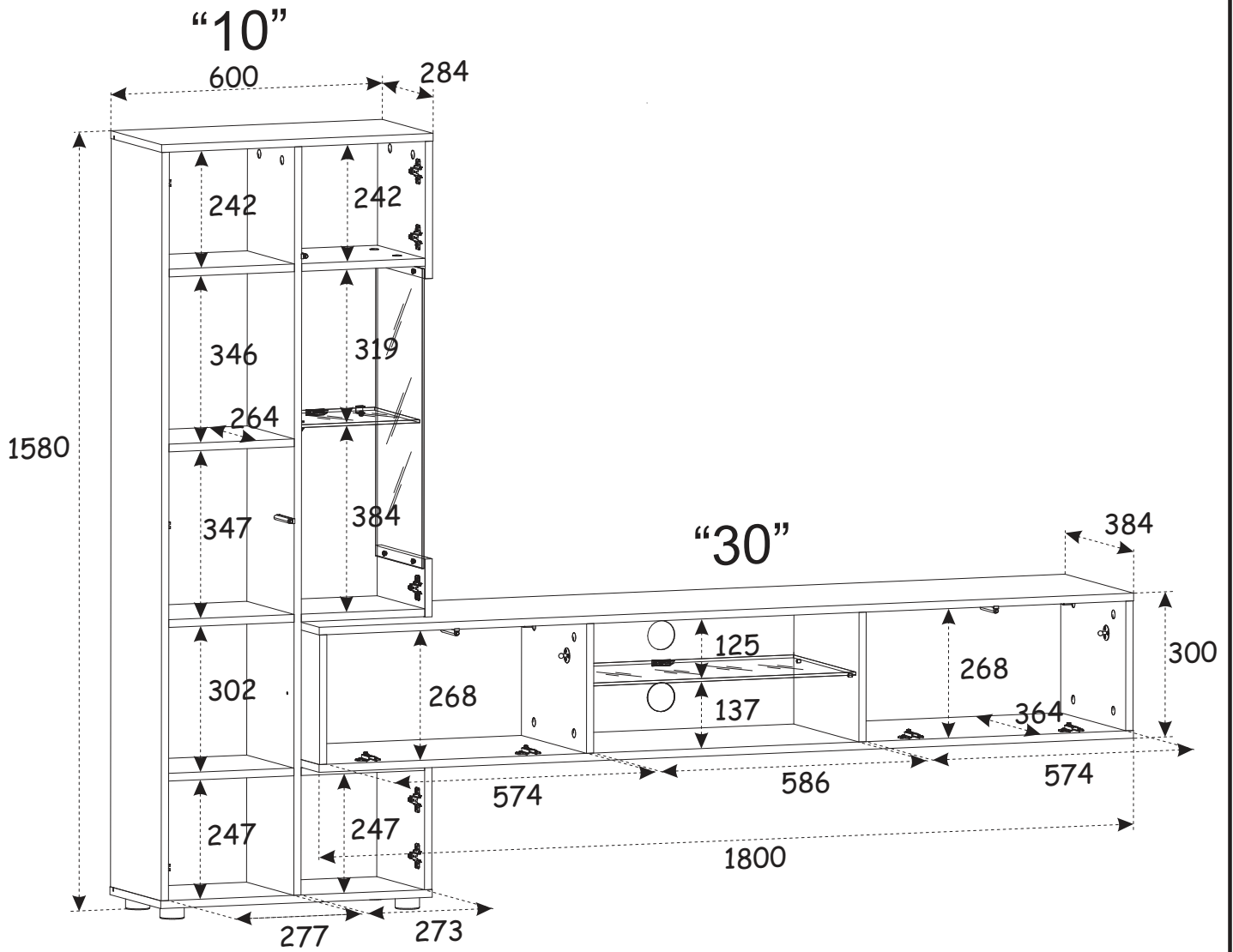

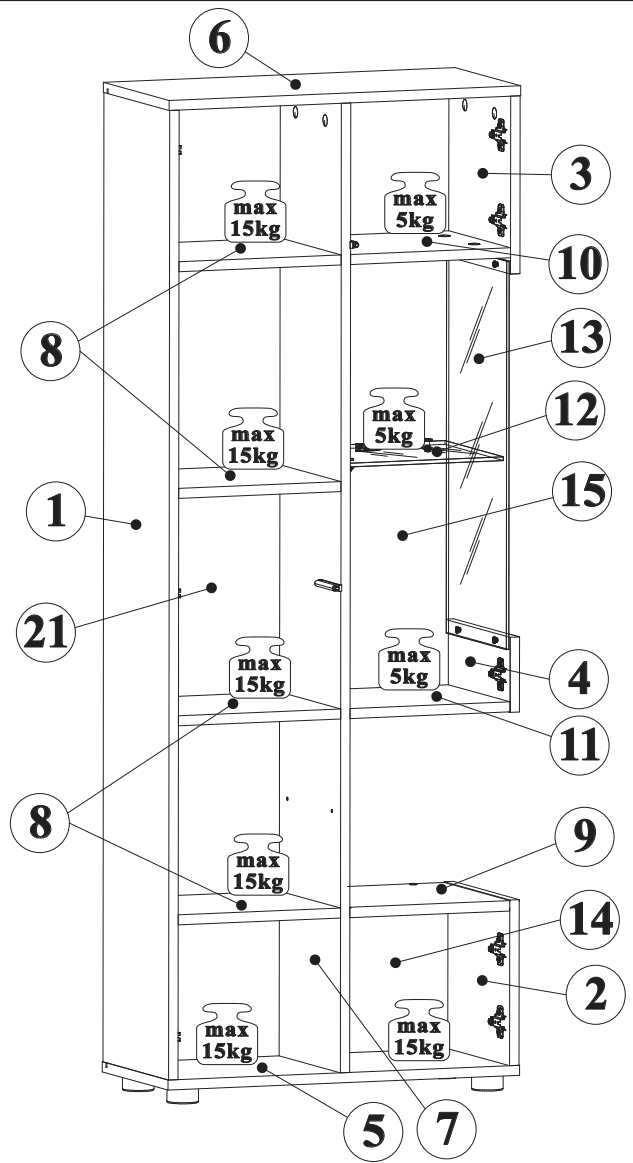
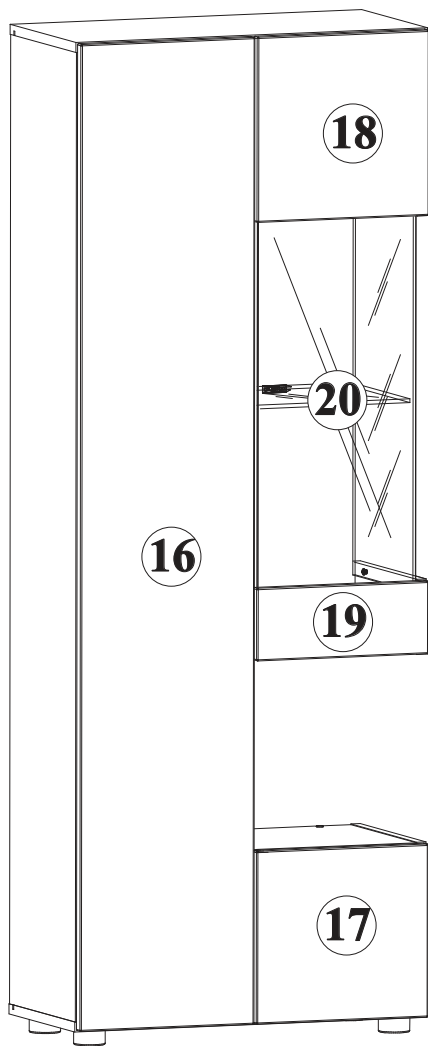

NO	Dim			Col.-No	Qty
1	1548	284	16	2	1
2	264	284	16	1	1
3	284	284	16	1	1
4	284	120	16	1	1
5	600	284	16	1	1
6	600	284	16	1	1
7	1548	284	16	2	1
8	277	264	16	1	4
9	273	284	16	1	1
10	273	267	16	1	1
11	273	267	16	1	1
12	263	252	6	1	1
13	620	260	4	1	1
14	247	273	16	2	1
15	984	273	16	2	1

NO	Dim			Col.-No	Qty
16	297	1576	16	2	1
17	293	276	16	2	1
18	293	296	16	2	1
19	293	116	16	2	1
20	624	269	4	1	1
21	1560	289	3	2	1

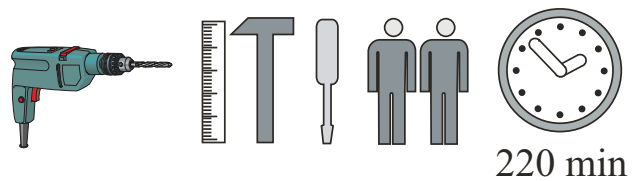



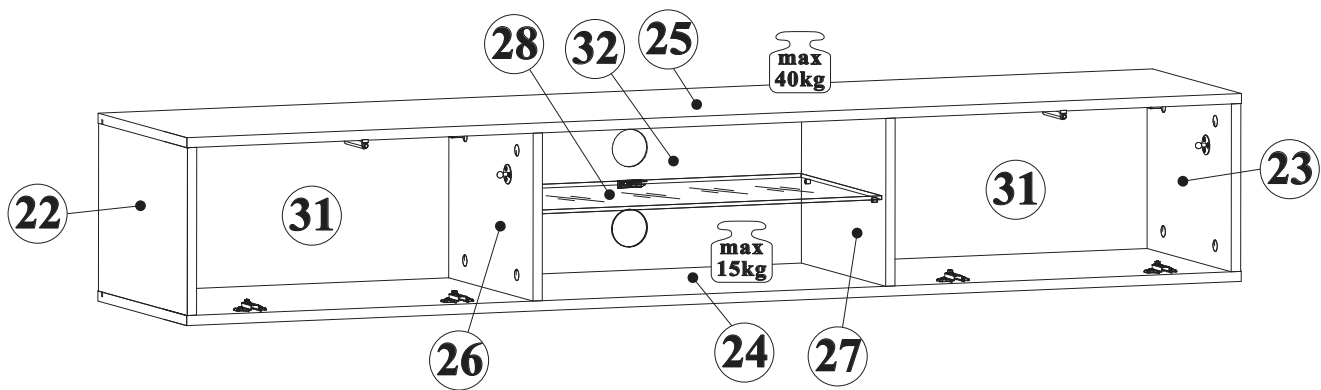
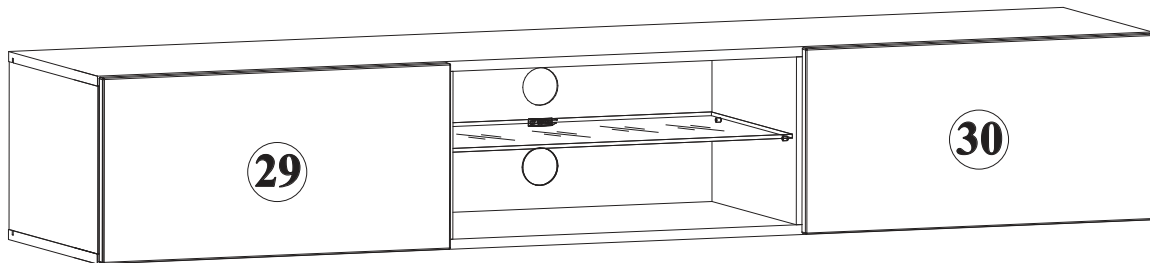



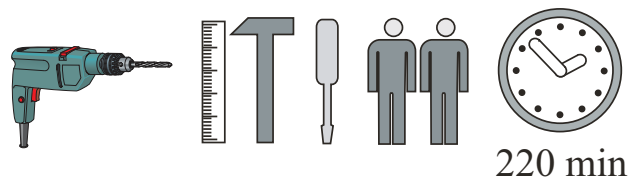

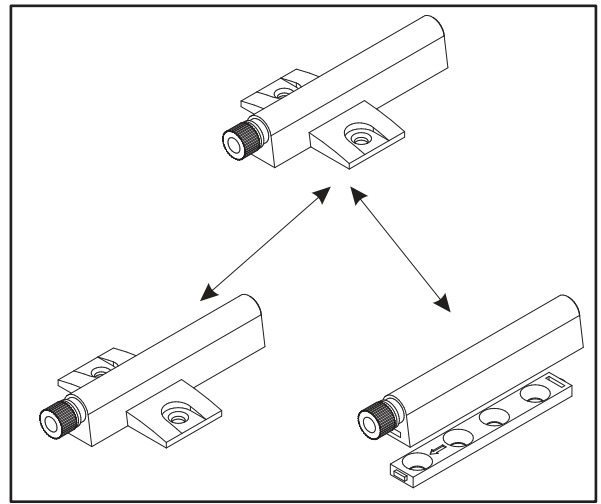
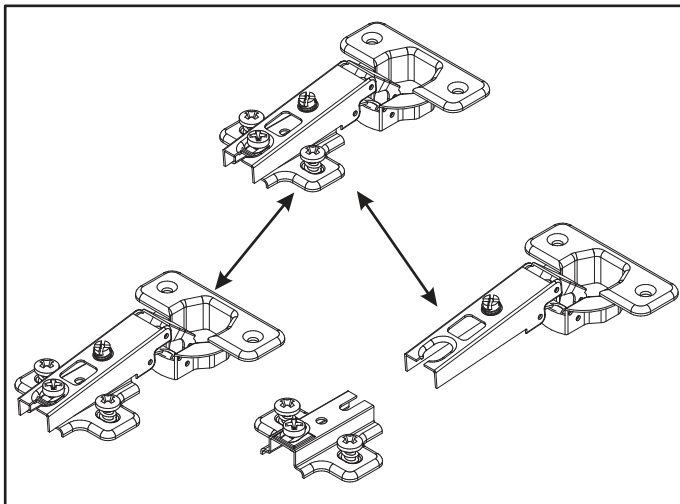
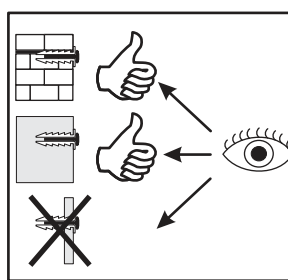
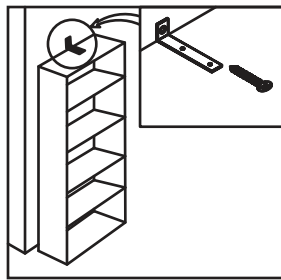
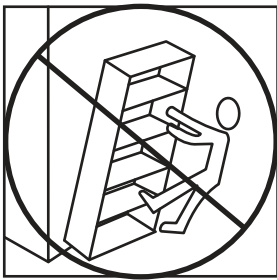
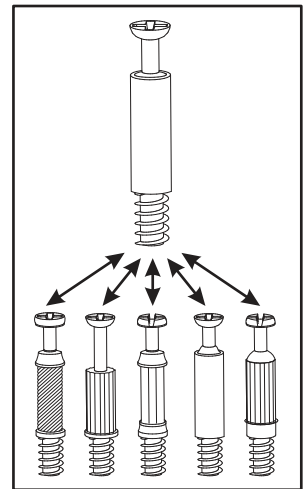
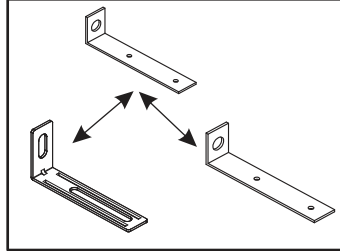
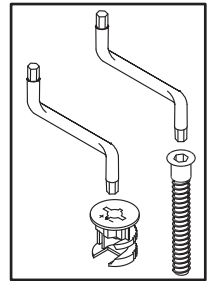
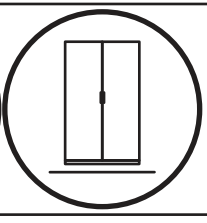
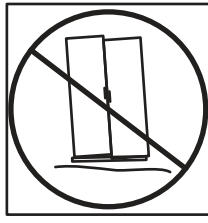
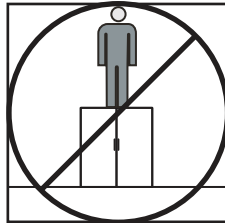
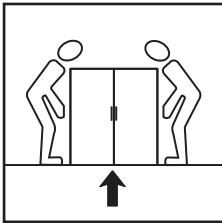
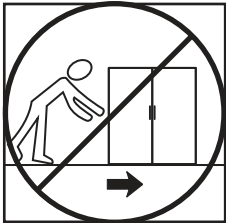
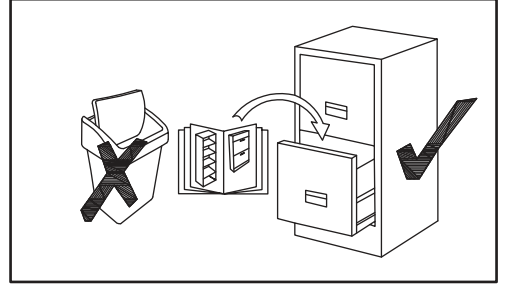
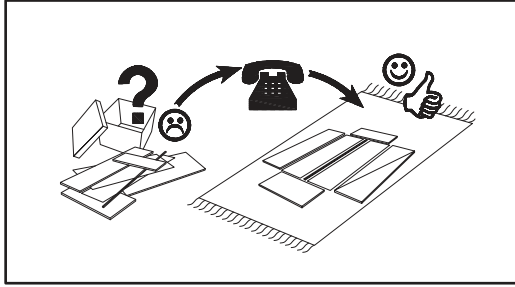
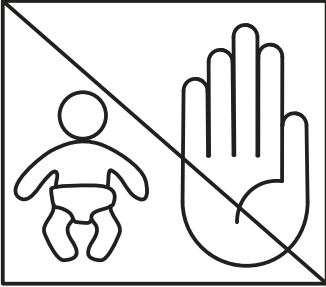
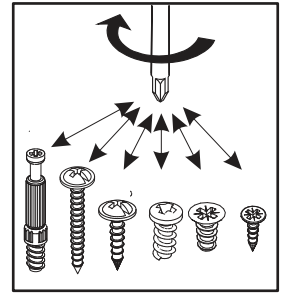
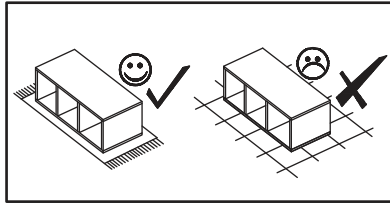
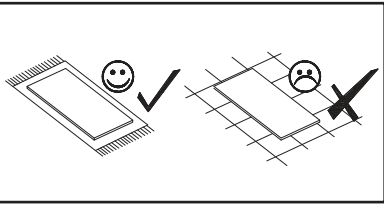

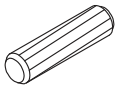

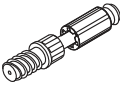

220 min

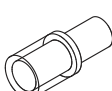
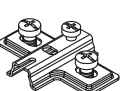
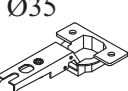
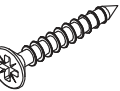
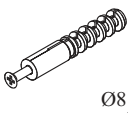
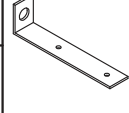
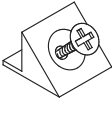
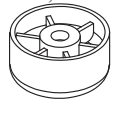

NO	Dim			Col.-No	Qty
22	268	384	16	3	1
23	268	384	16	3	1
24	1800	384	16	3	1
25	1800	384	16	3	1
26	268	364	16	3	1
27	268	364	16	3	1
28	584	349	6	3	1
29	594	296	16	3	1
30	594	296	16	3	1
31	587	280	3	3	1
31	587	280	3	3	1
32	600	280	3	3	1

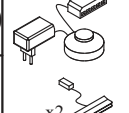
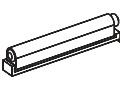
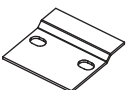

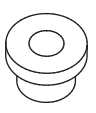
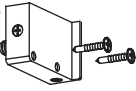
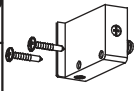
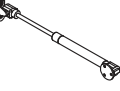
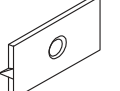

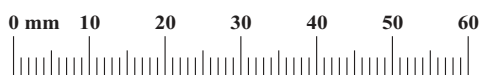
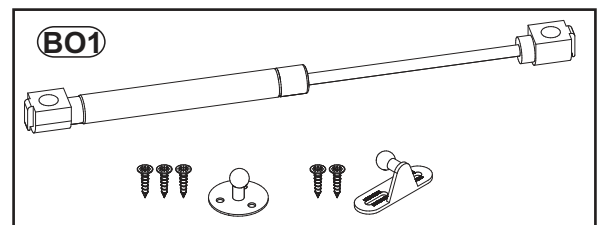
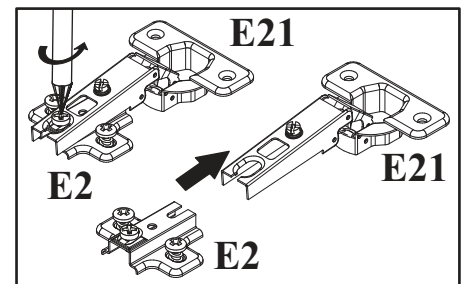

A1 x56  Ø8x36	B11 x14  Ø7x50	G4 x14 	B4 x42 	B6 x6  Ø7x76	B5 x54  Ø15x12
G5 x56 	G8 x2  Ø20	G20 x4 	E2 x12  H=0	E21 x12  Ø35 H=0	D6 x10  USØ3,5x30
KR1 x9  Ø8	L1 x1 	S1 x26 	ST7 x4  Ø50, h=25	UP11 x4  UPØ4x20	D10 x56  USØ3,5x13
UP13 x20  UPØ3x16	LED x1  x2	T1 x5 	SZ7 x4 	G30 x4 	P2 x8 
ZXL x2 	ZXP x2 	BO1 x4 	G16 x4 	G2 x1 	

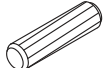

1

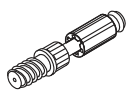
A1	
x4	∅8x36



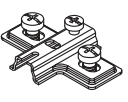

B4	
x8	

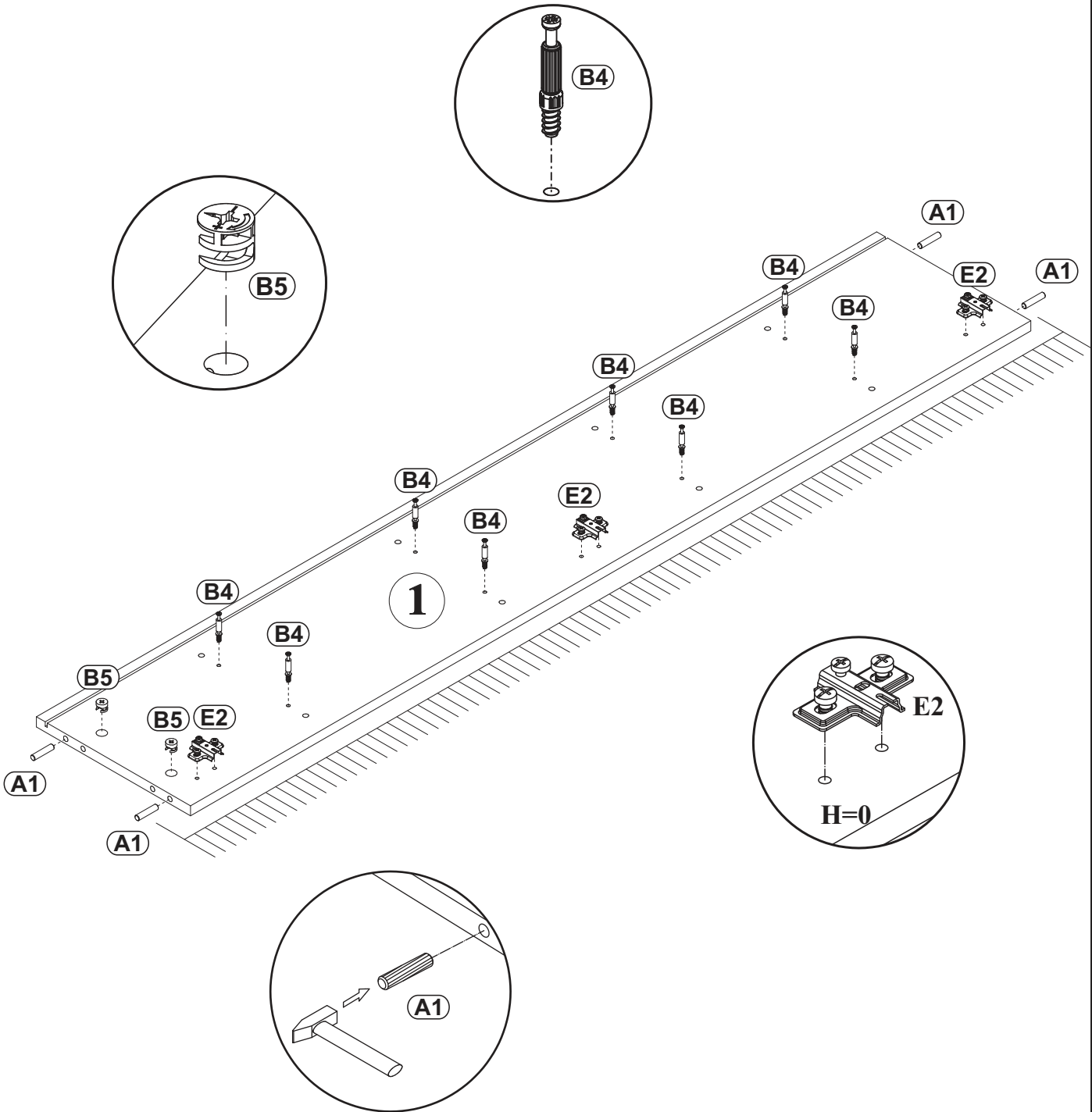
B5	
x2	∅15x12

E2	
x3	H=0

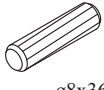
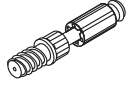
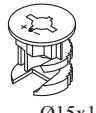

2

A1		B4		B5	
x4	ø8x36	x2		x2	Ø15x12
G30		D10		T1	
x2		x6	USØ3,5x13	x3	

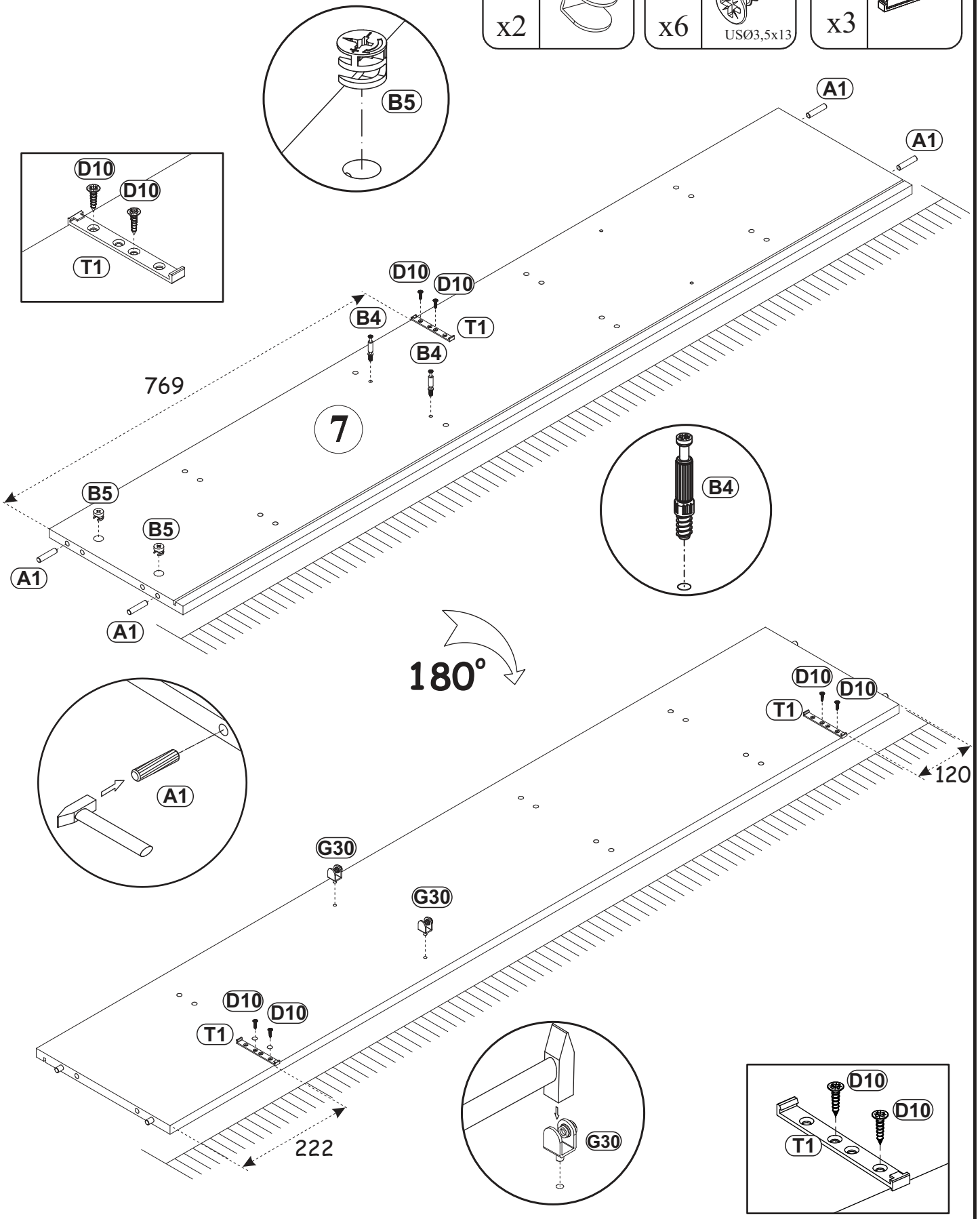

3

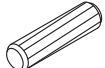
A1	
x4	∅8x36

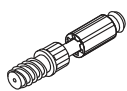
B4	
x8	

B5	
x2	∅15x12

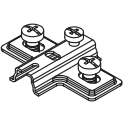
E2	
x5	H=0

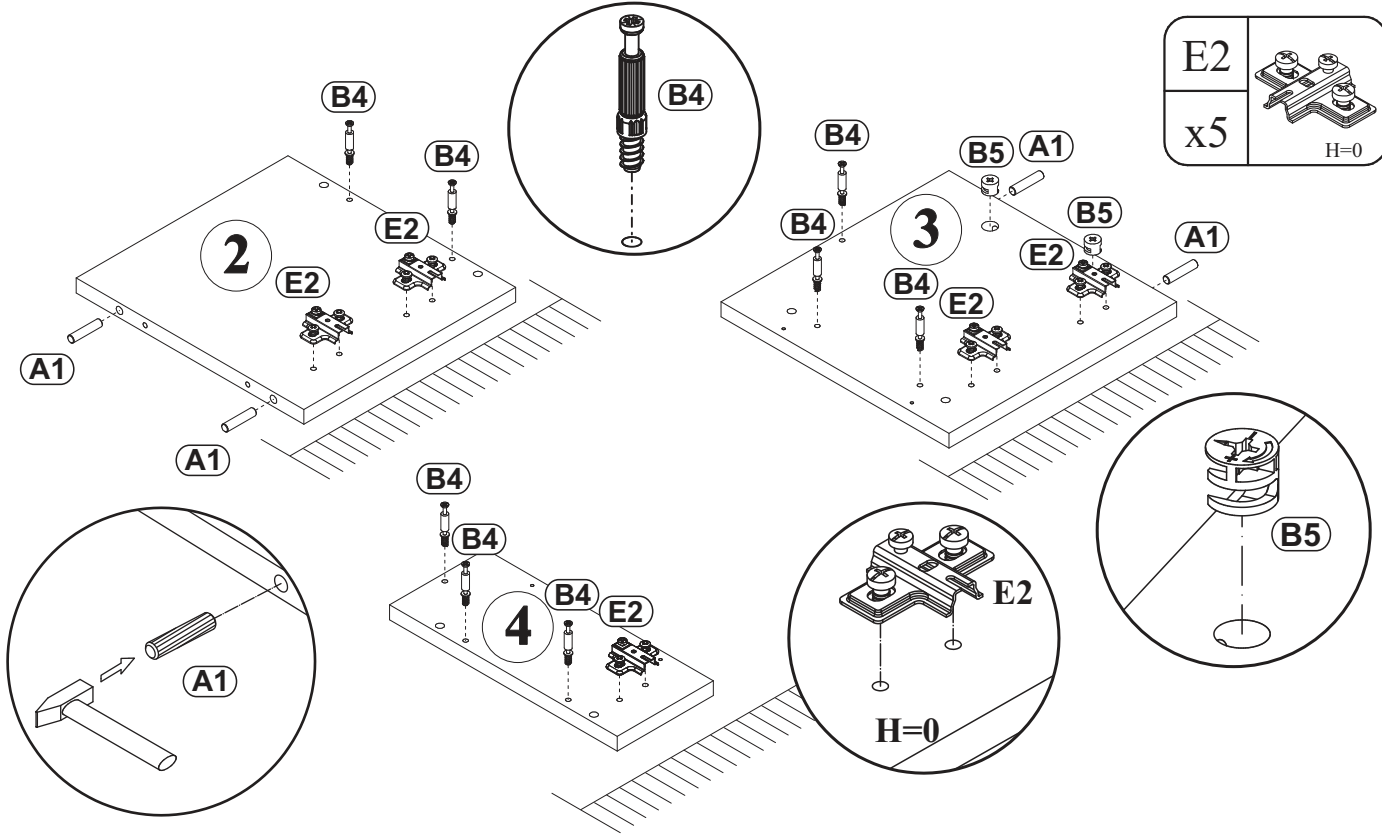

4

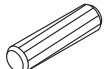
A1	
x24	∅8x36

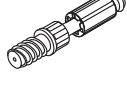
B4	
x8	

B5	
x24	∅15x12

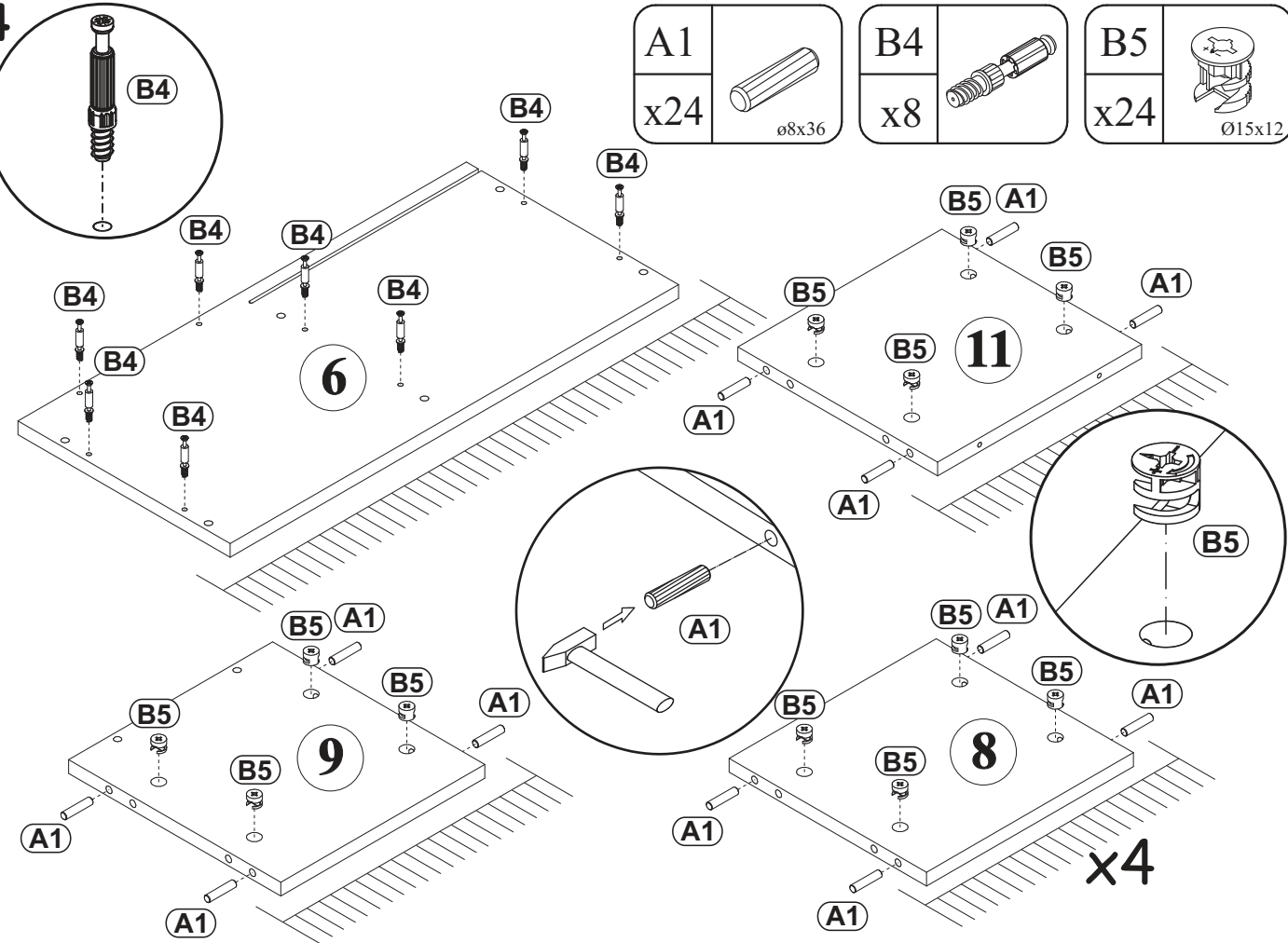

5

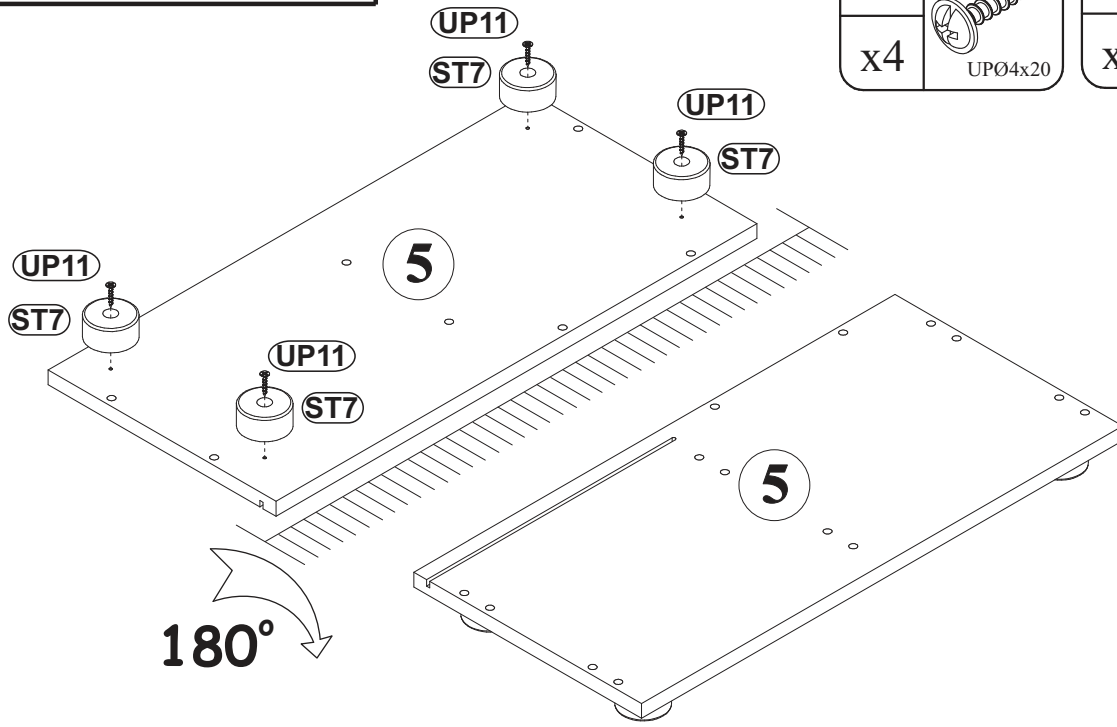

UP11	
x4	UPØ4x20

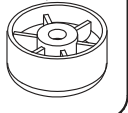
ST7	
x4	Ø50, h=25

6

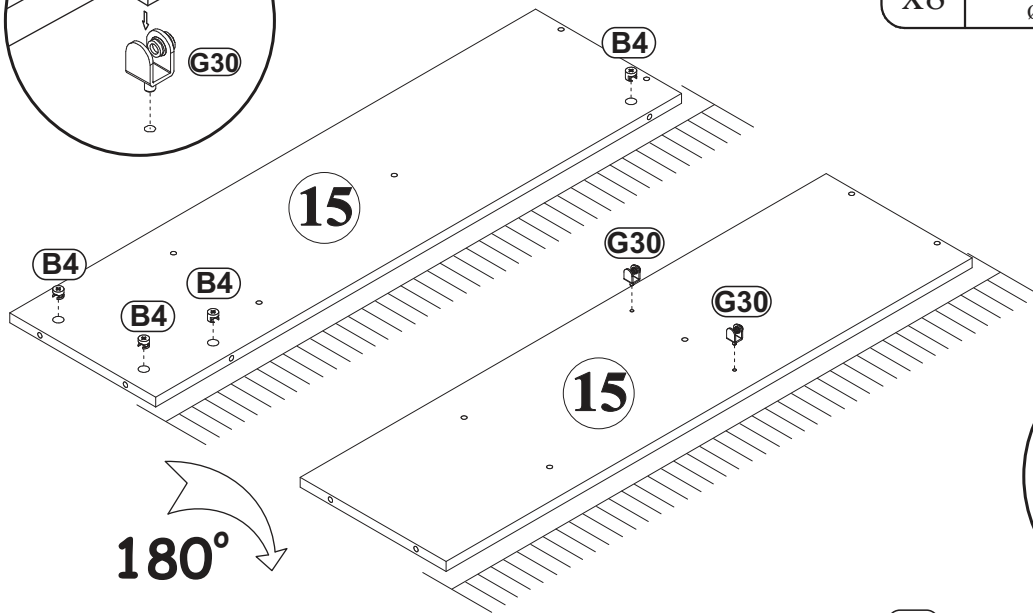
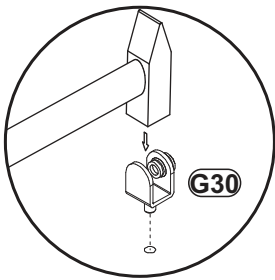

B5	
x8	Ø15x12

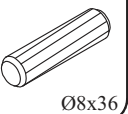
A1	
x4	Ø8x36

G30	
x2	

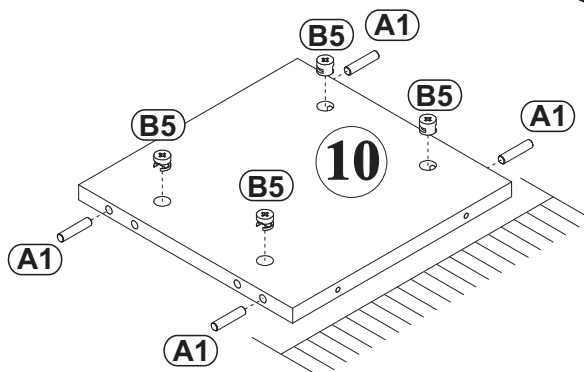
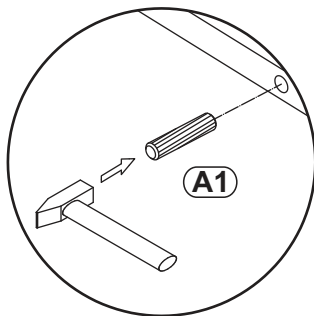
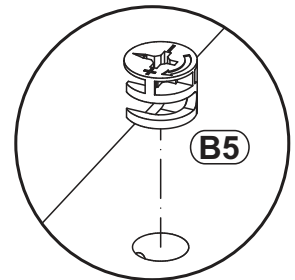

D10	
x4	USØ3,5x13

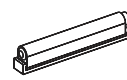
T1	
x2	

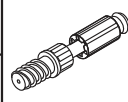
B4	
x8	

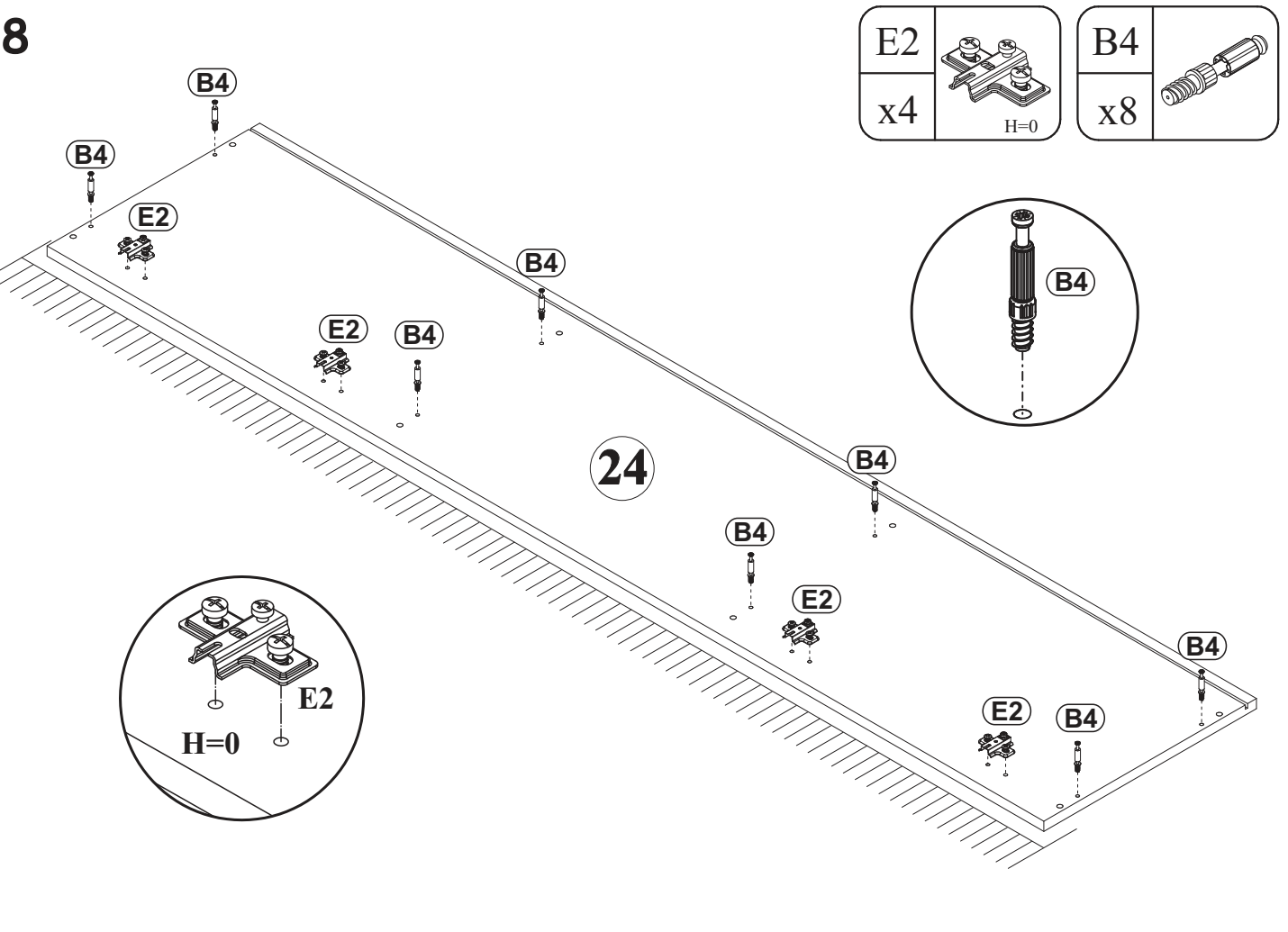
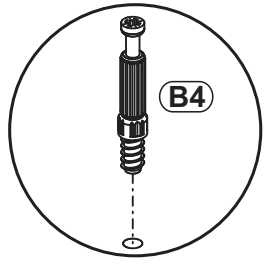
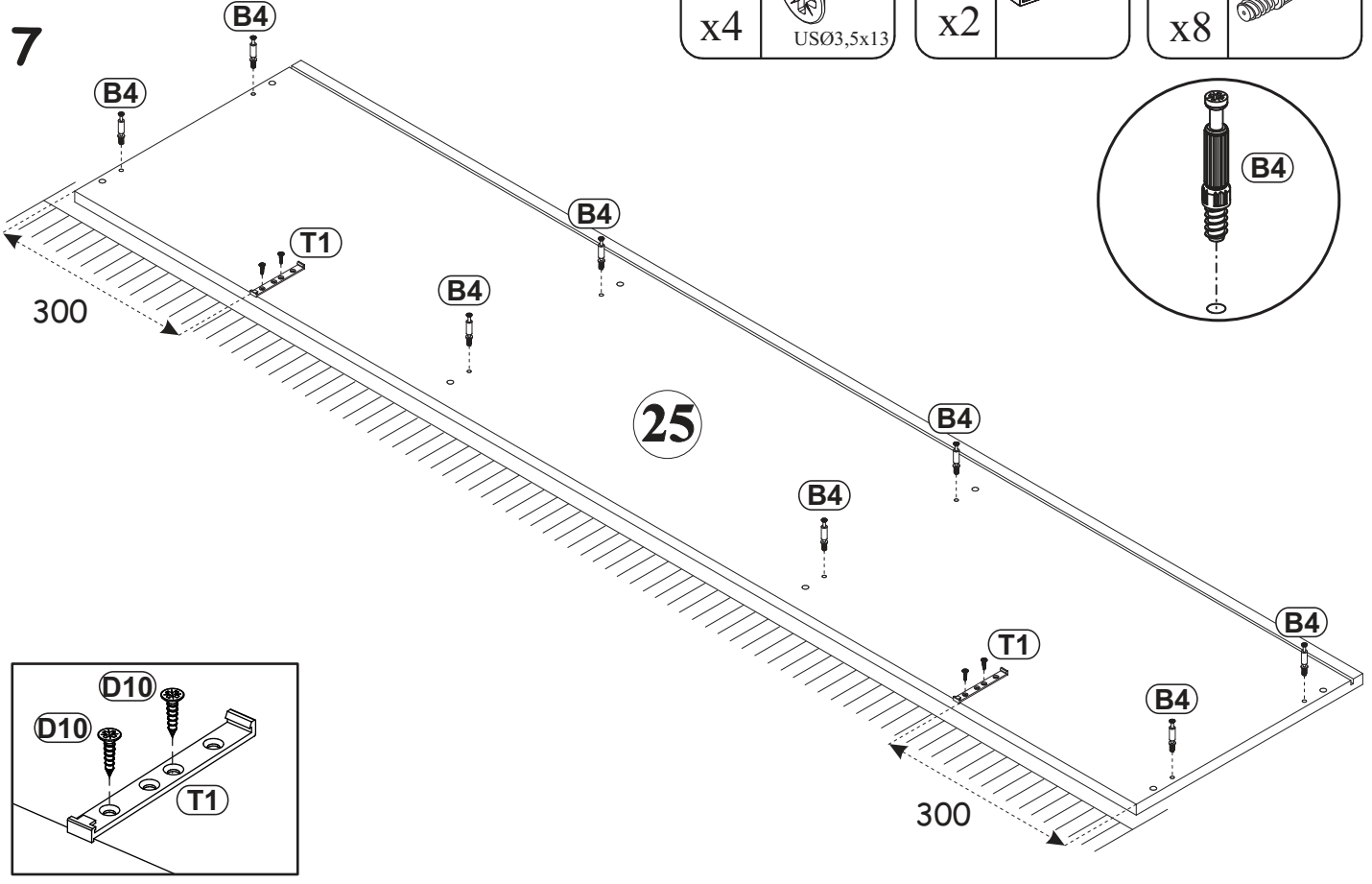

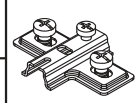
E2	
x4	H=0

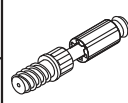
B4	
x8	

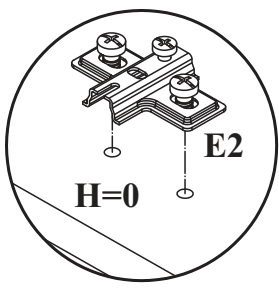
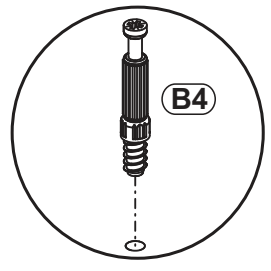

9

A1	
x16	Ø8x36

ZXP	
x2	

ZXL	
x2	

B5	
x16	Ø15x12

BO1	
x4	

D10	
x12	USØ3,5x13

G20	
x4	

D6	
x8	USØ3,5x30

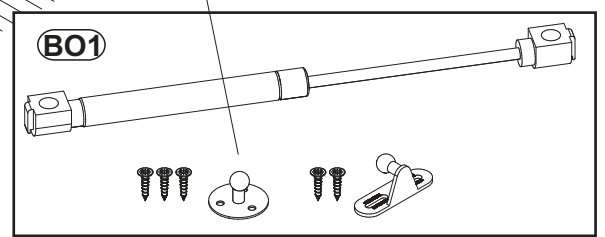
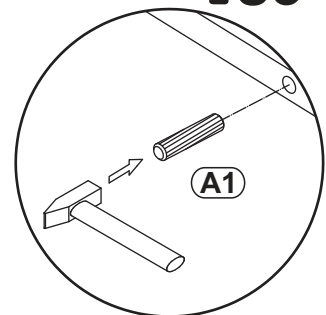
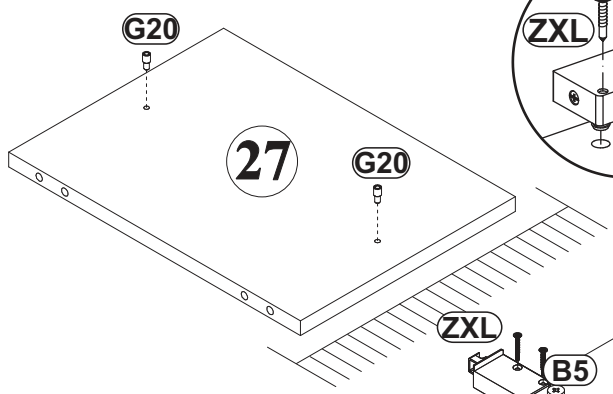
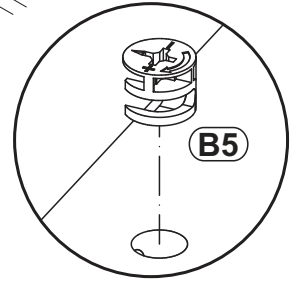
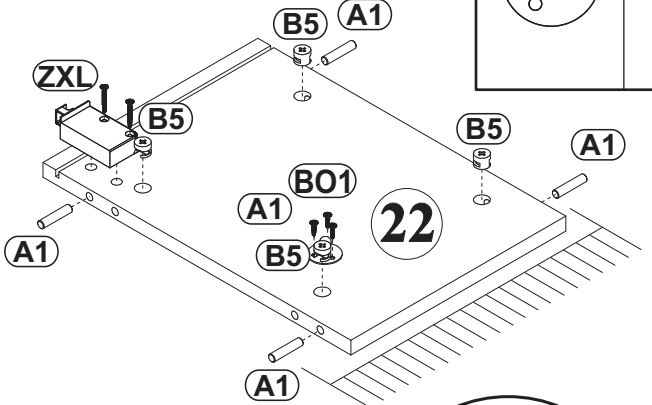
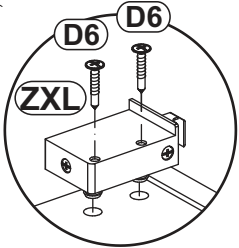
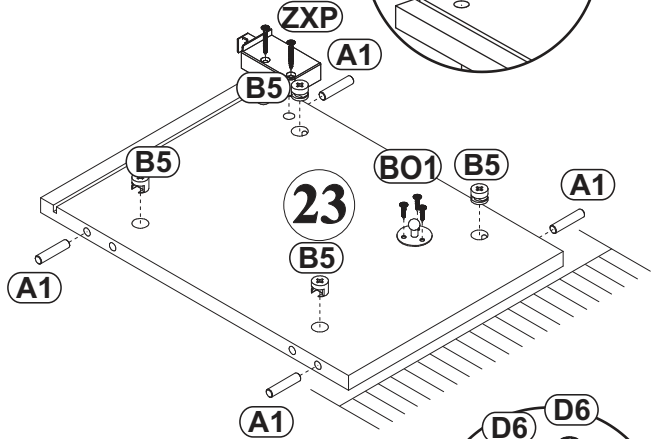
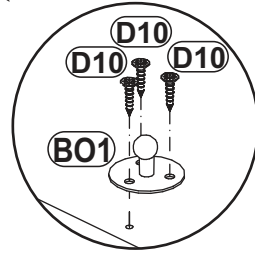
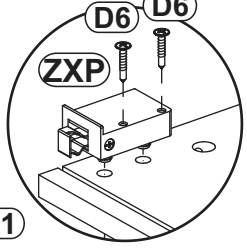
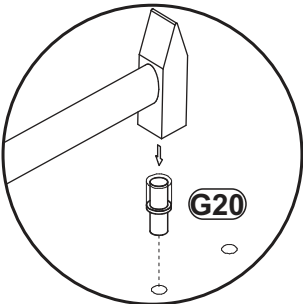
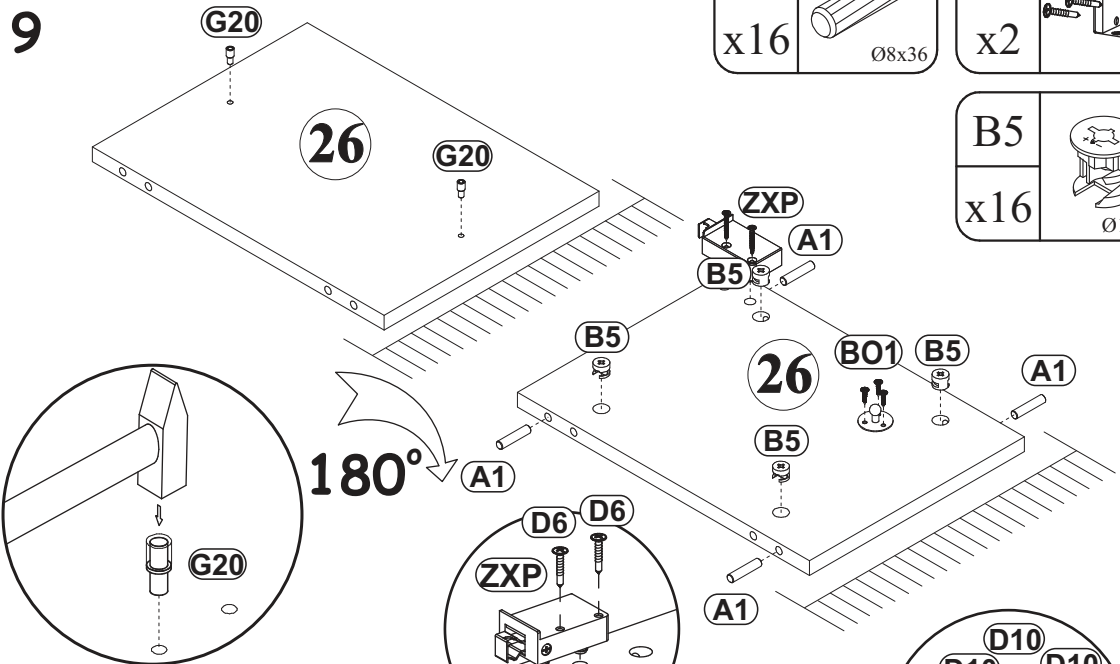
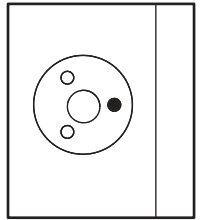

180°

10

D10	
x10	USØ3,5x13

E21	Ø35
x5	H=0

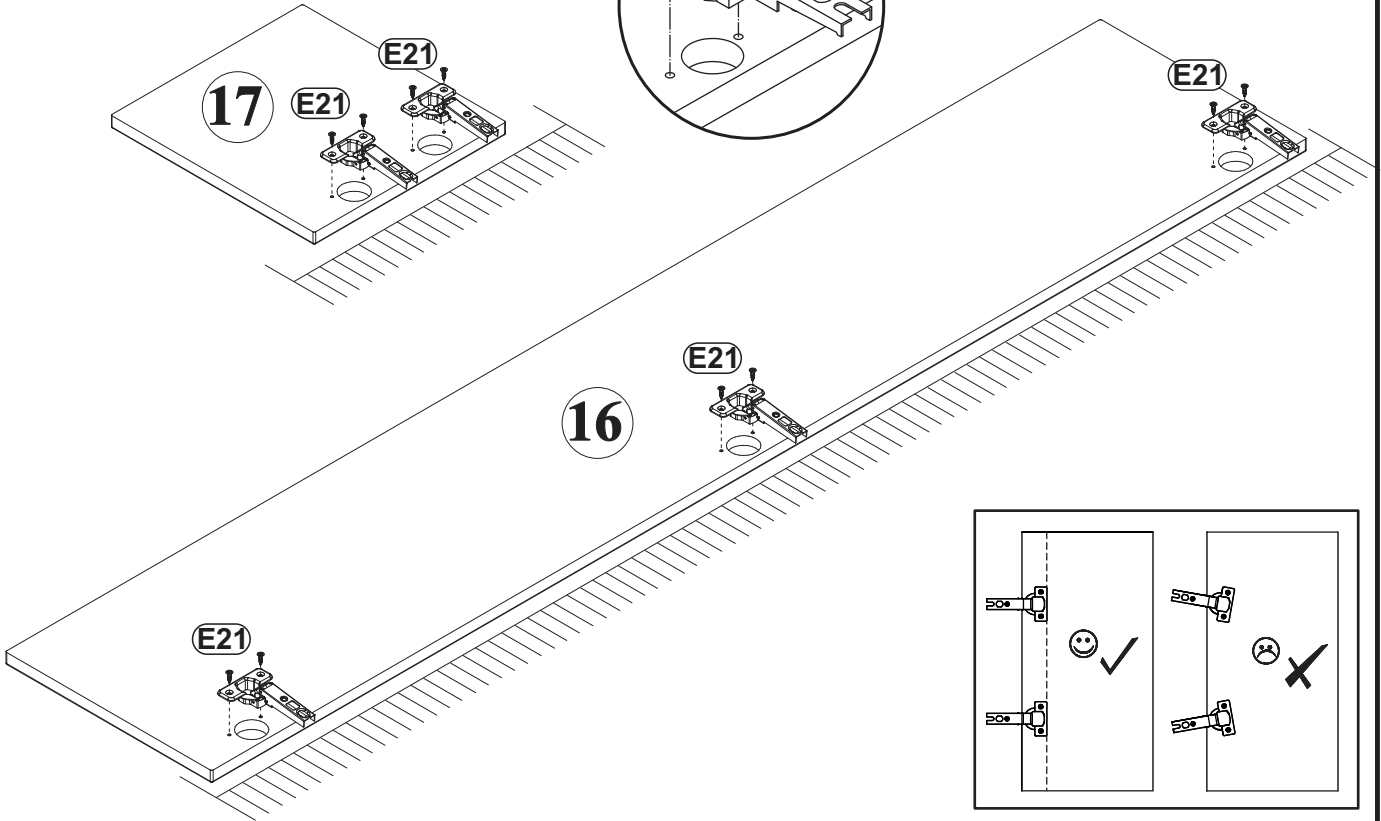
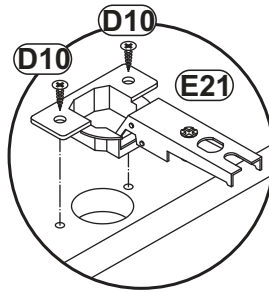

11

E21	Ø35
x4	H=0

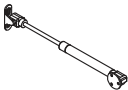
BO1	
x4	

D10	
x16	USØ3,5x13

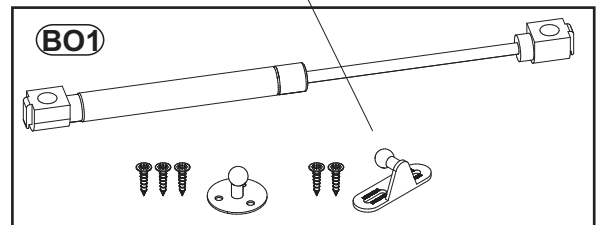
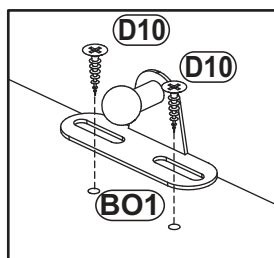
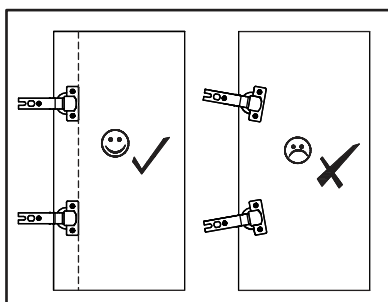
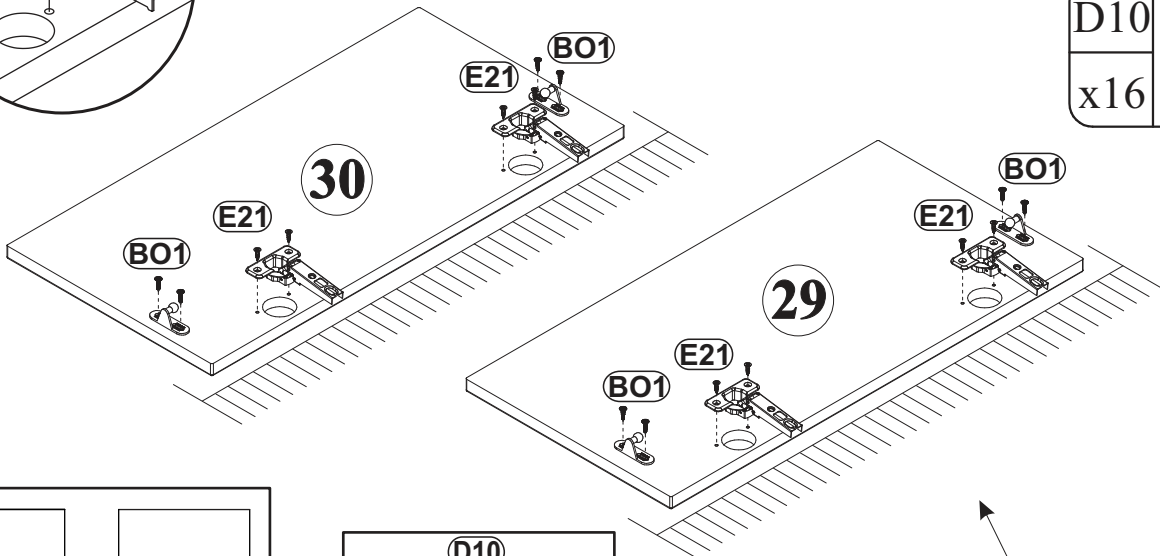
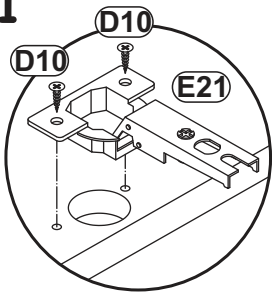

12

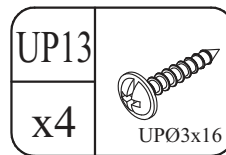
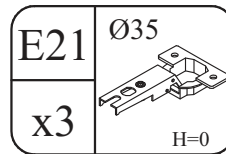
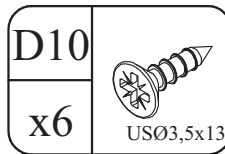
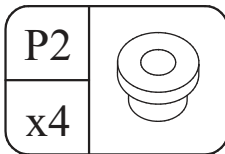

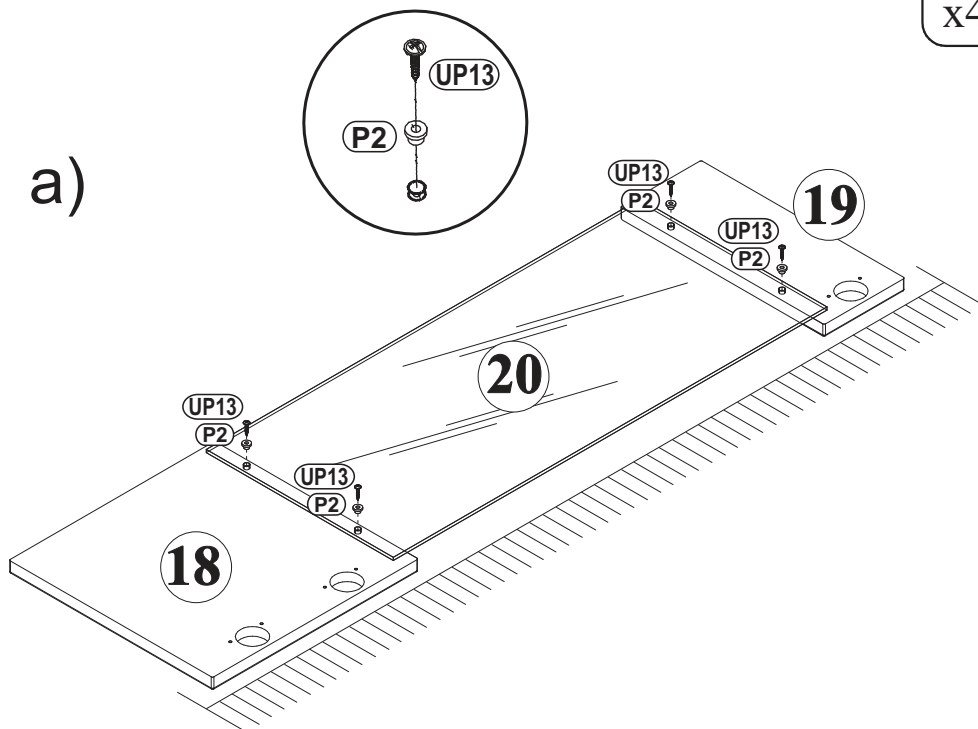

a)

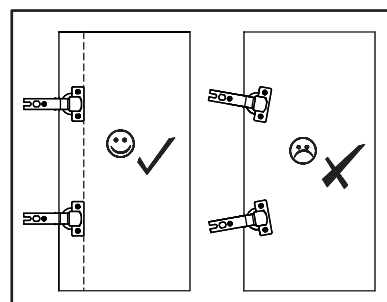
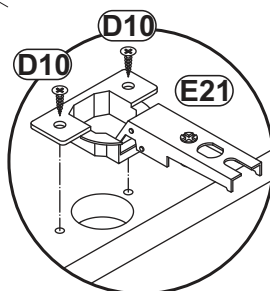
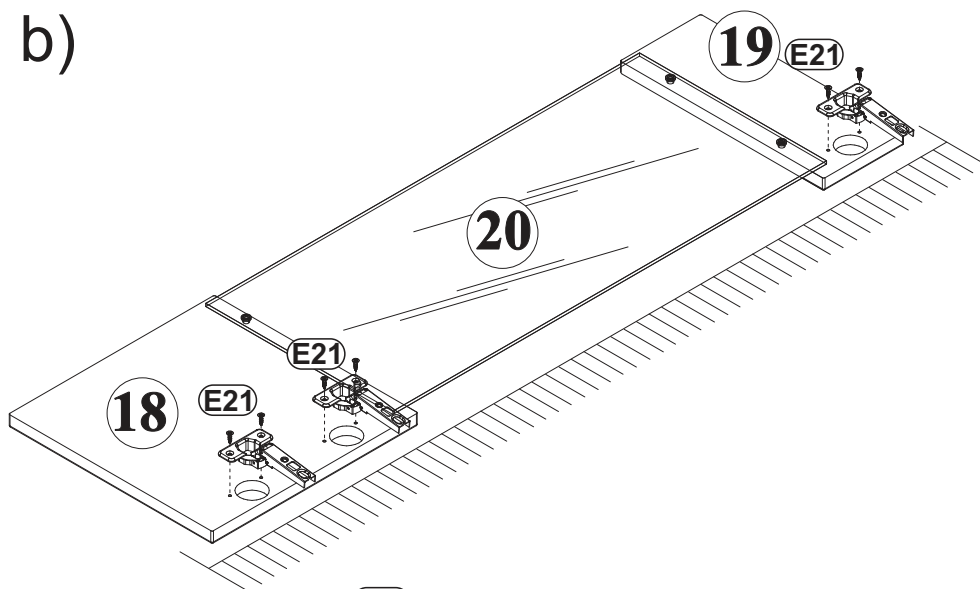

b)



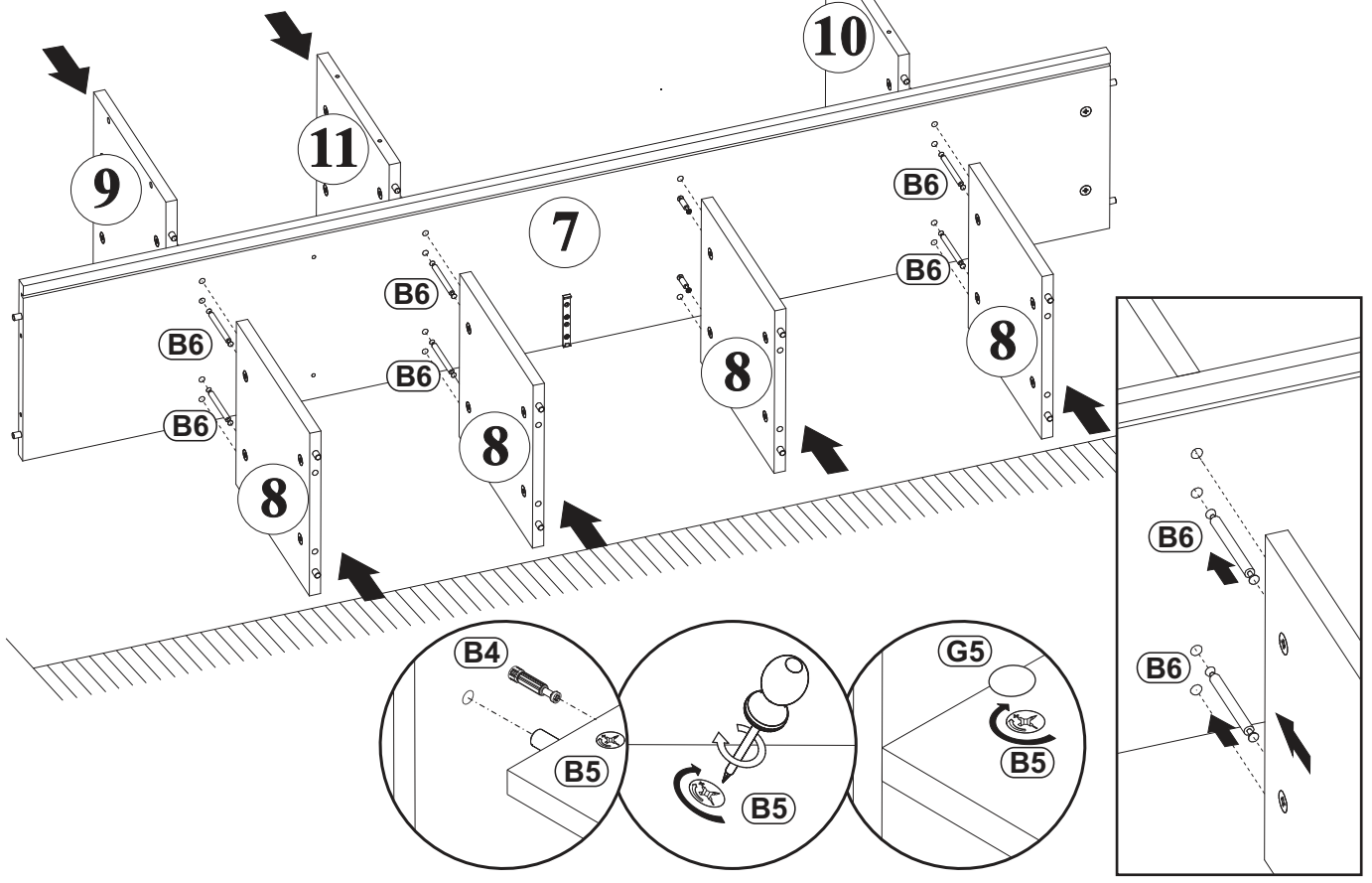

13

B6		G5	
x6	Ø7x76	x14	



14

B11		G4	
x4	Ø7x50	x4	

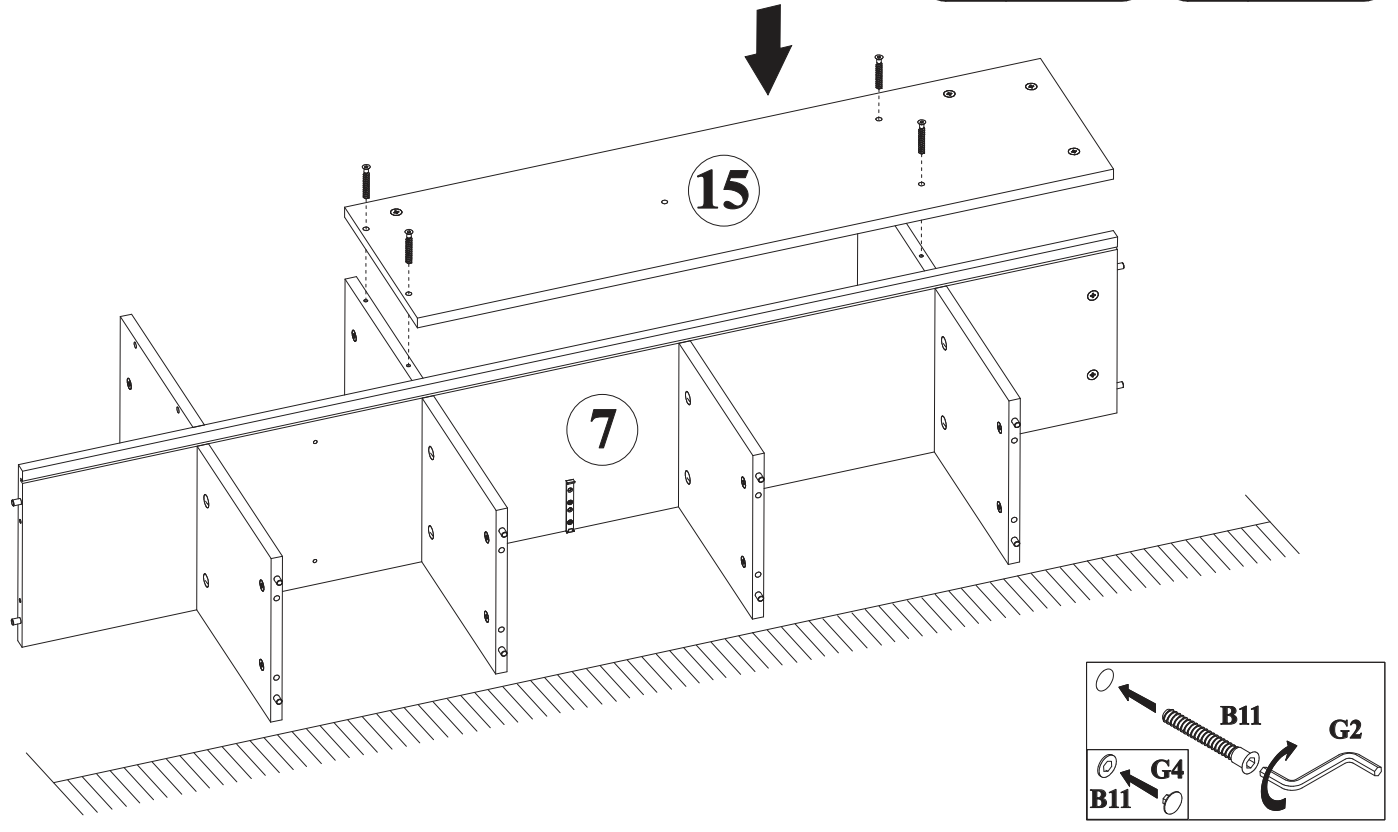

15

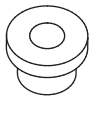
UP13		P2	
x4	UPØ3x16	x4	

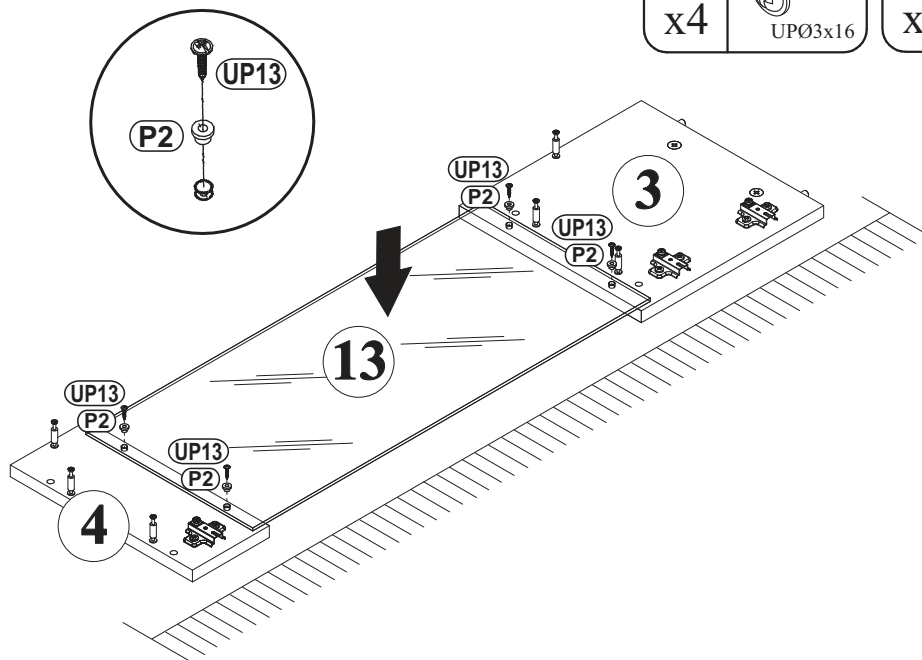

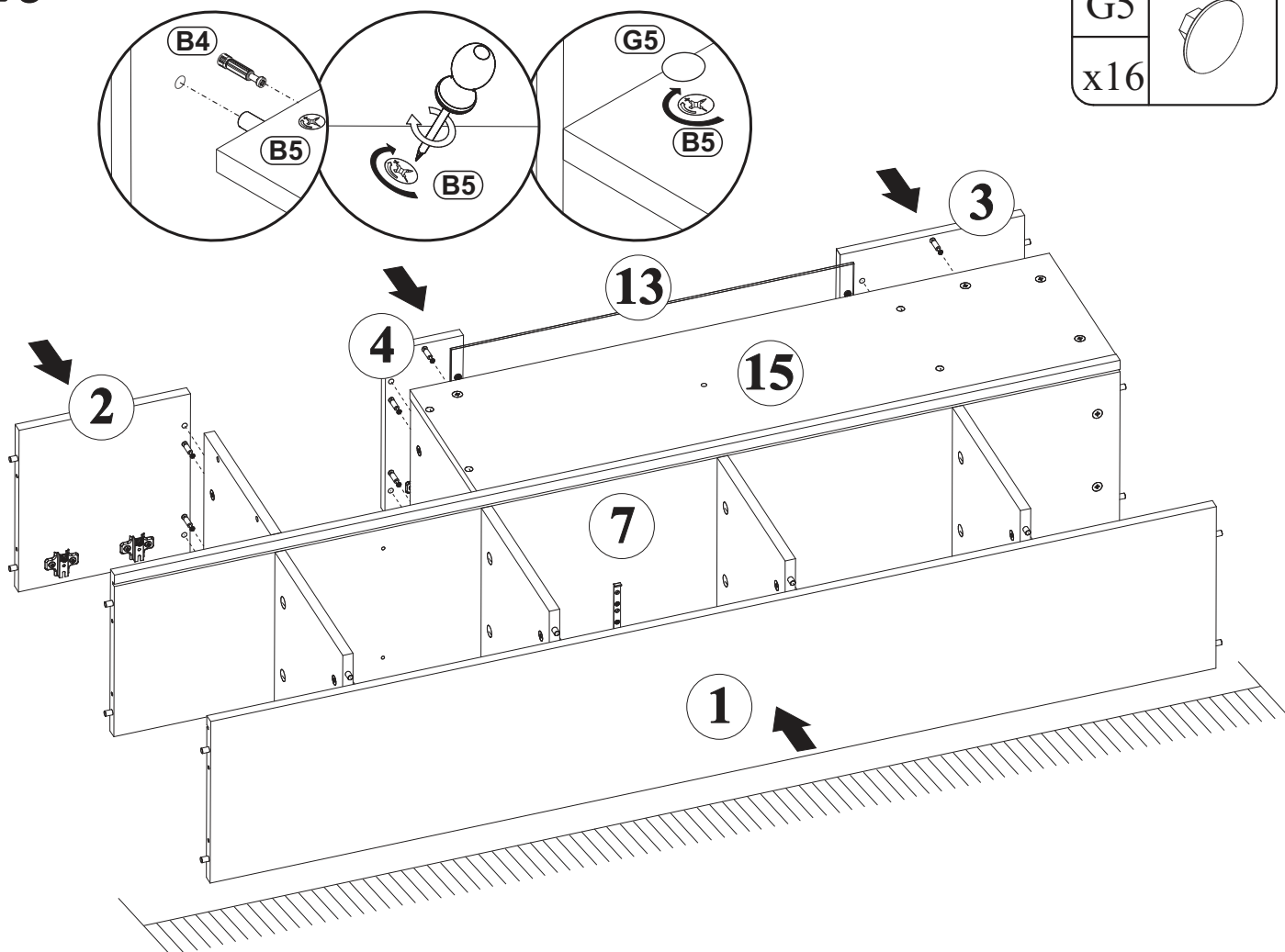

16

G5	
x16	



17

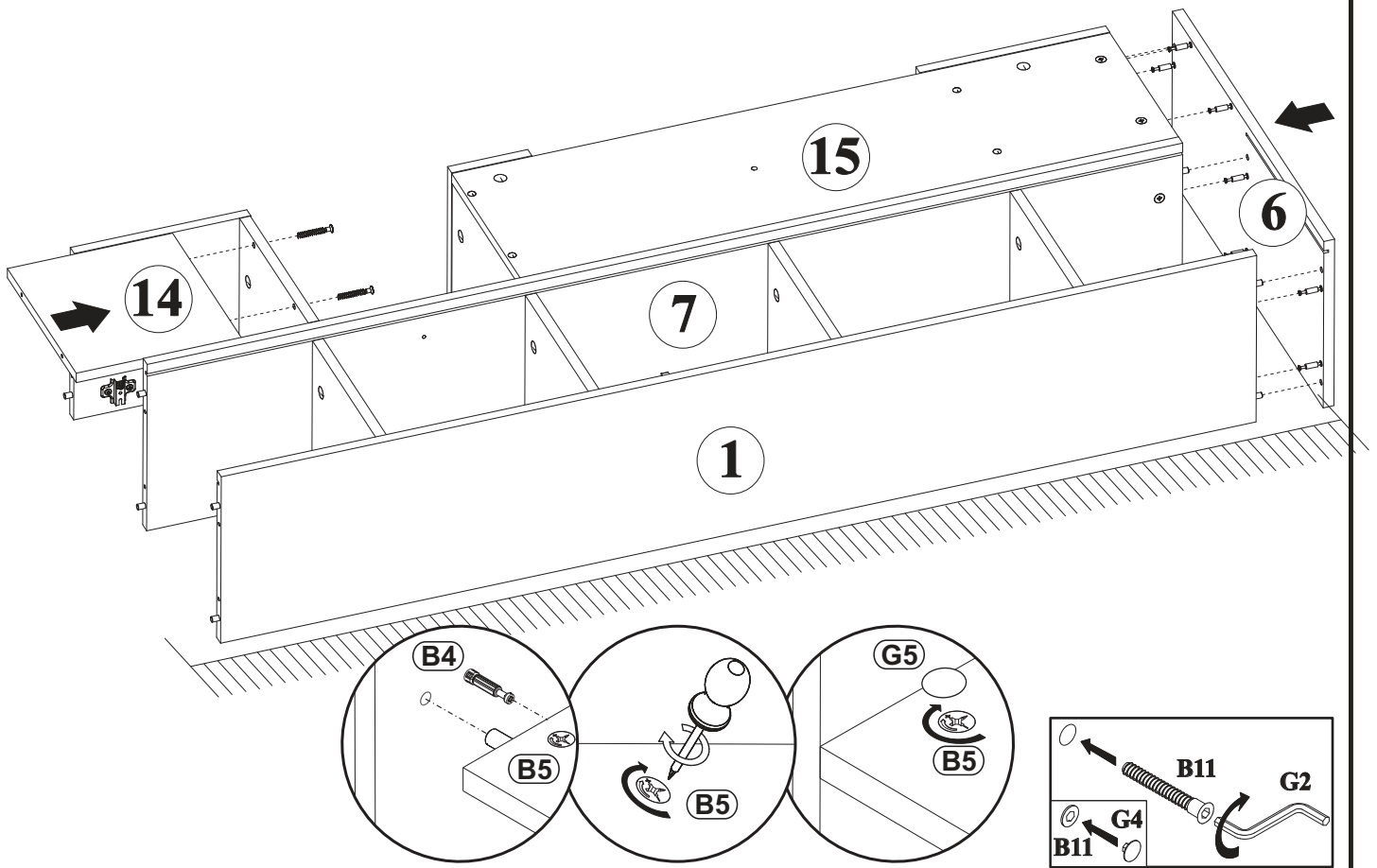

G5		B11	
x8		x2	Ø7x50

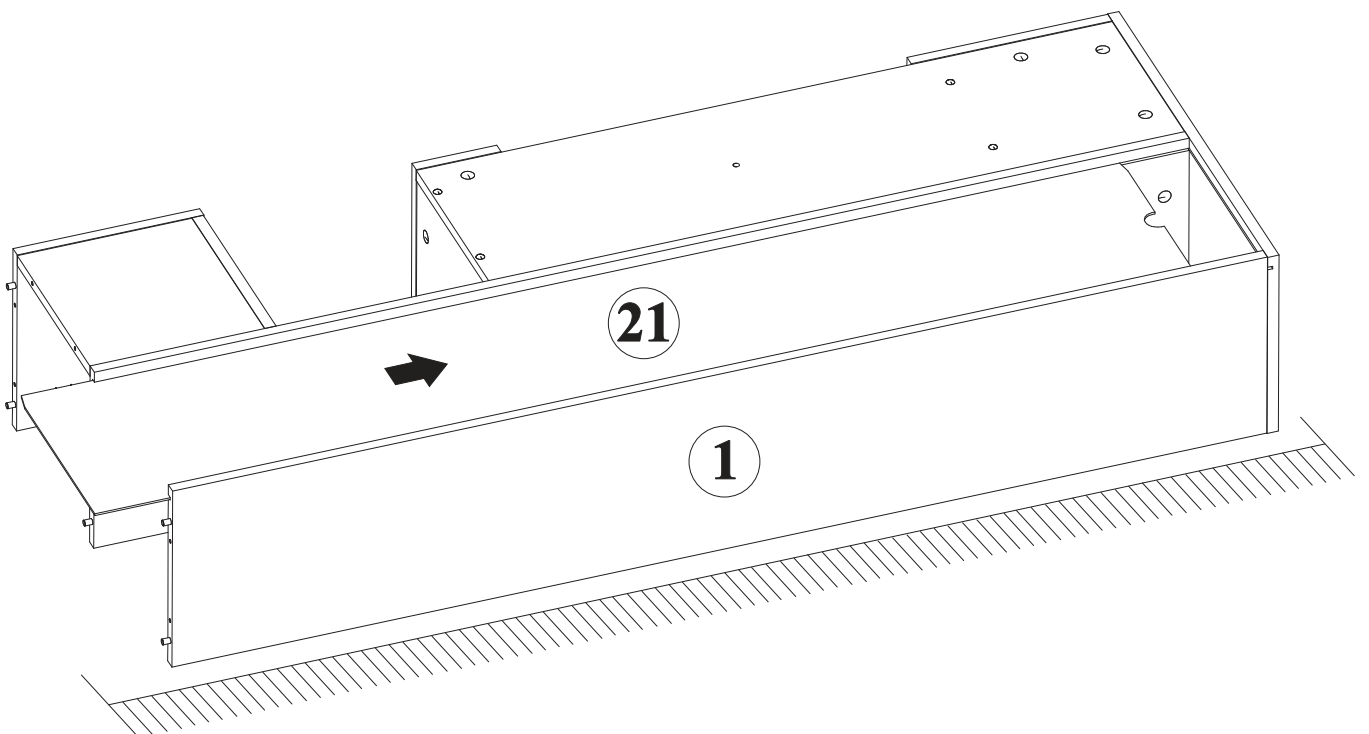

18



19

B11		G4	
x8	Ø7x50	x8	

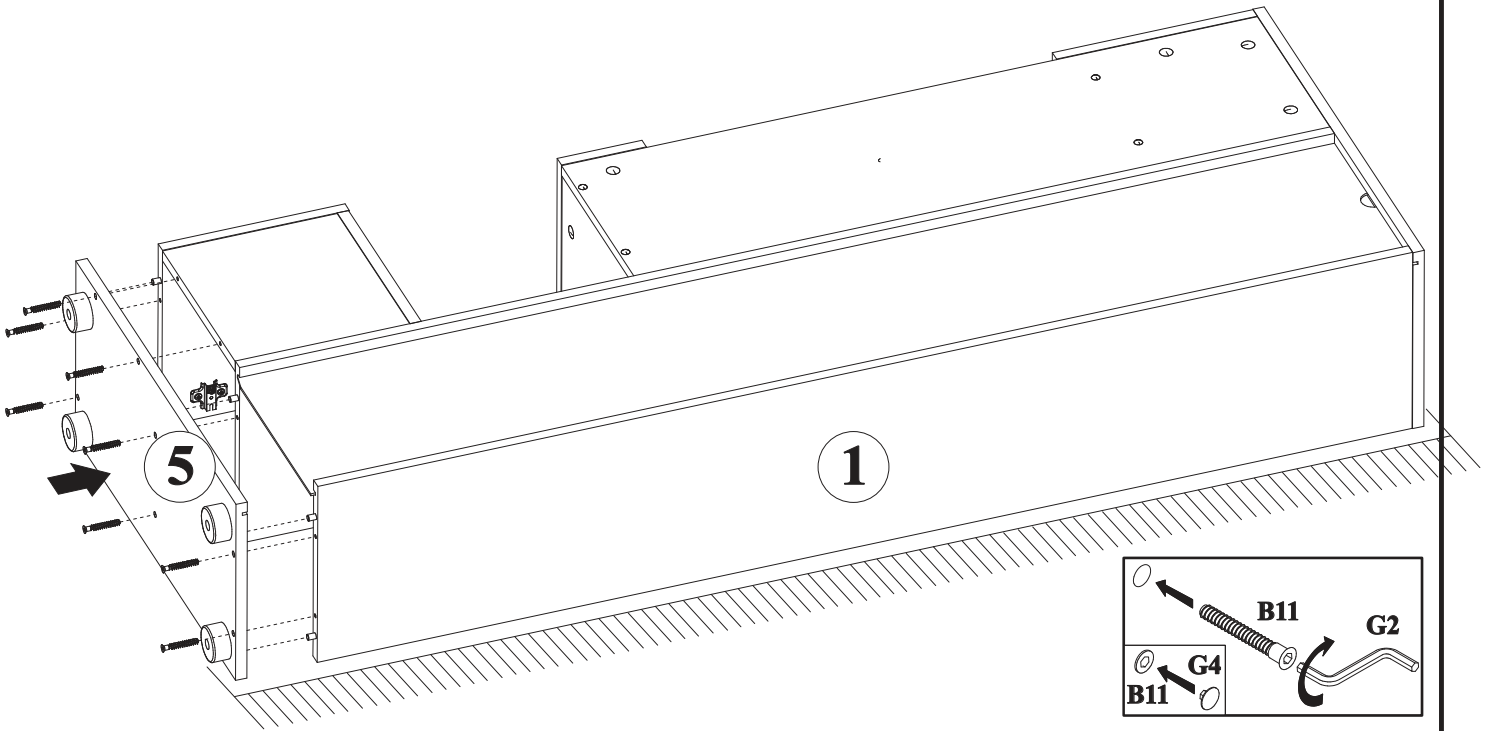

20

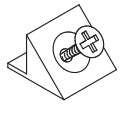
UP13		S1	
x8	UPØ3x16	x12	

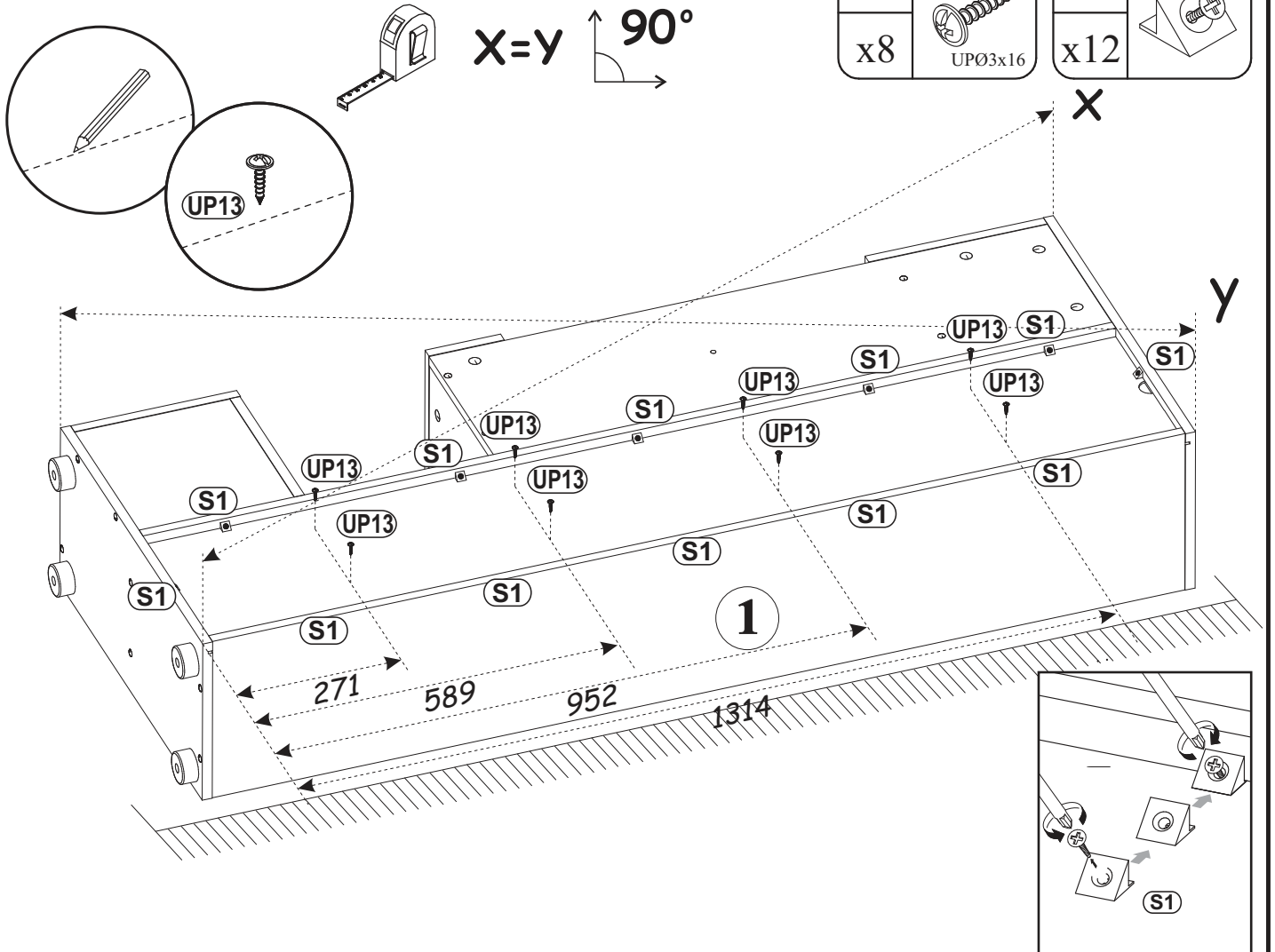

21

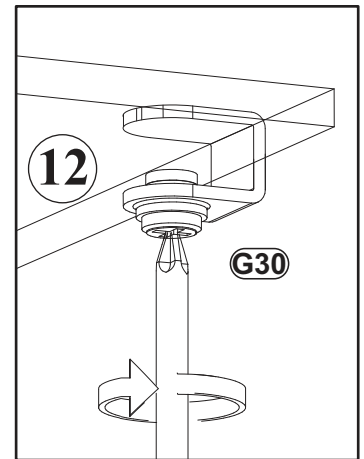
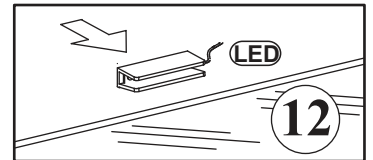
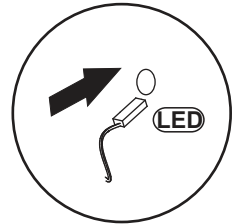
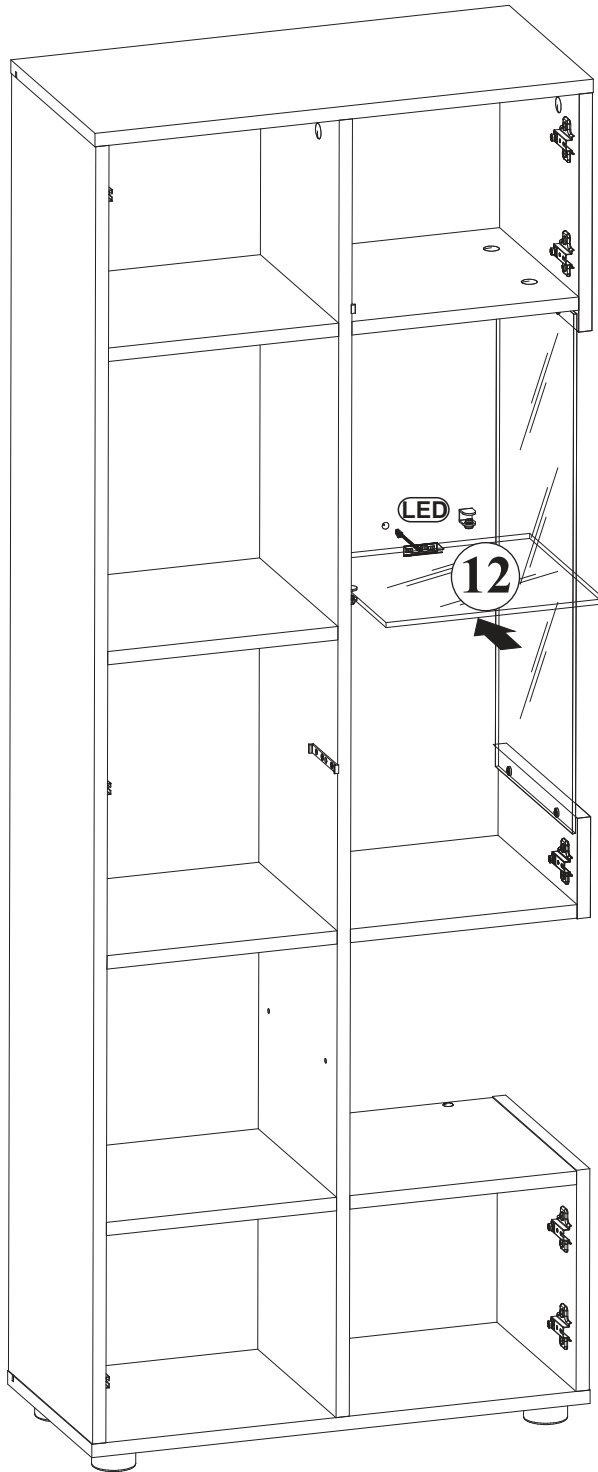
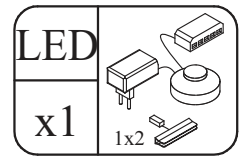

22

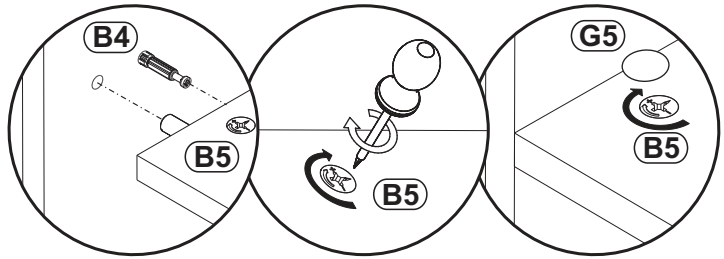
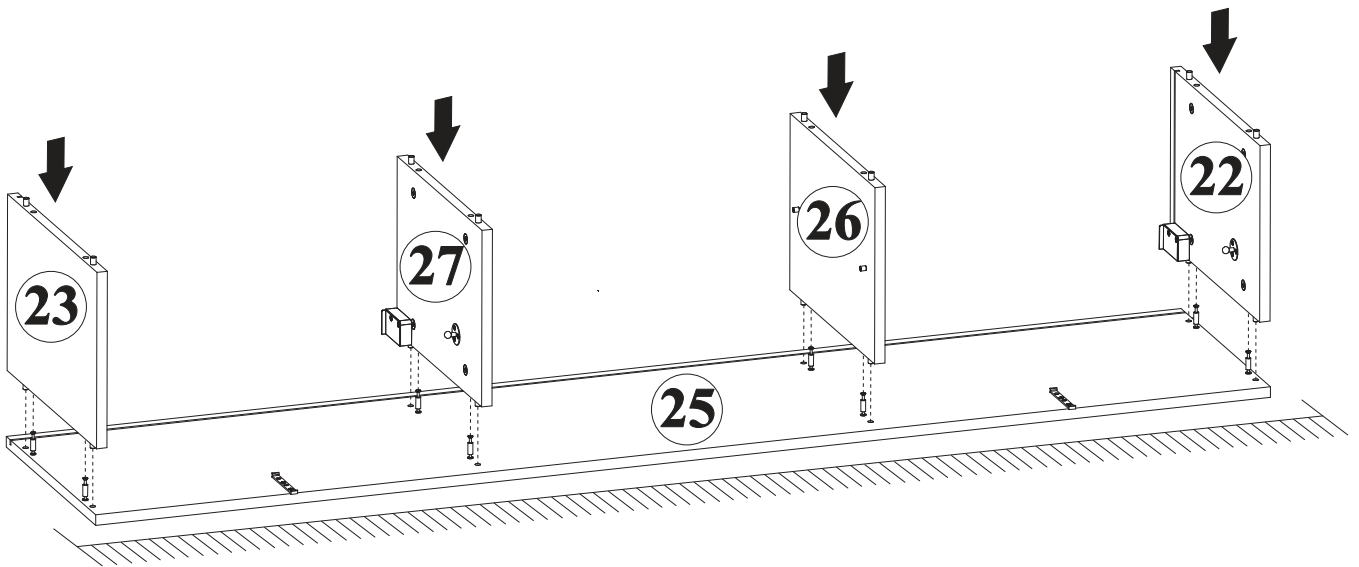
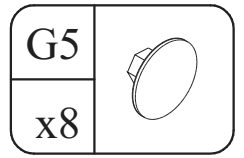

23

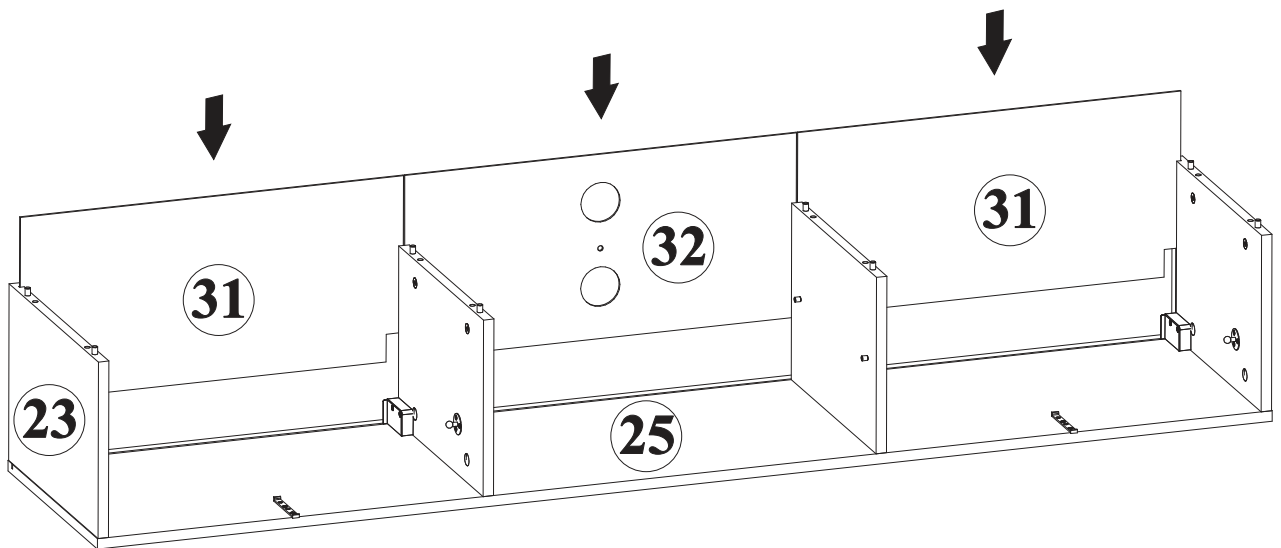

24

G5	
x8	

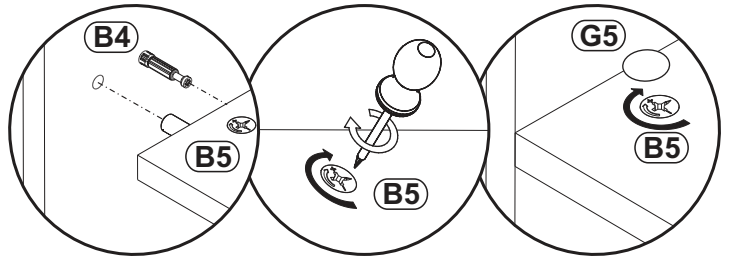
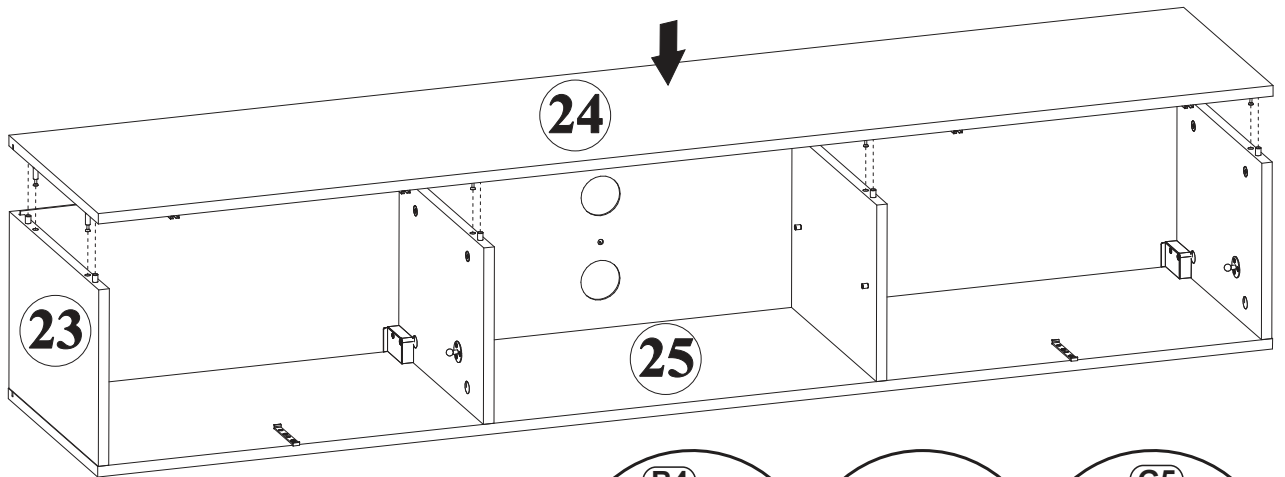

25

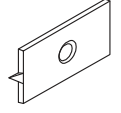

G16	
x4	

UP13	
x4	UPØ3x16

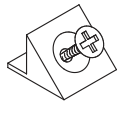
S1	
x14	

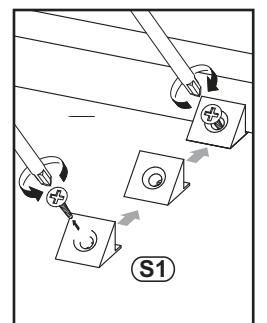
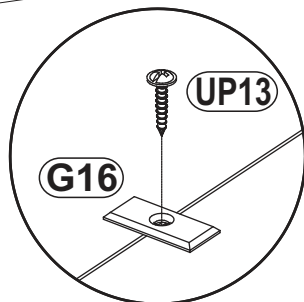
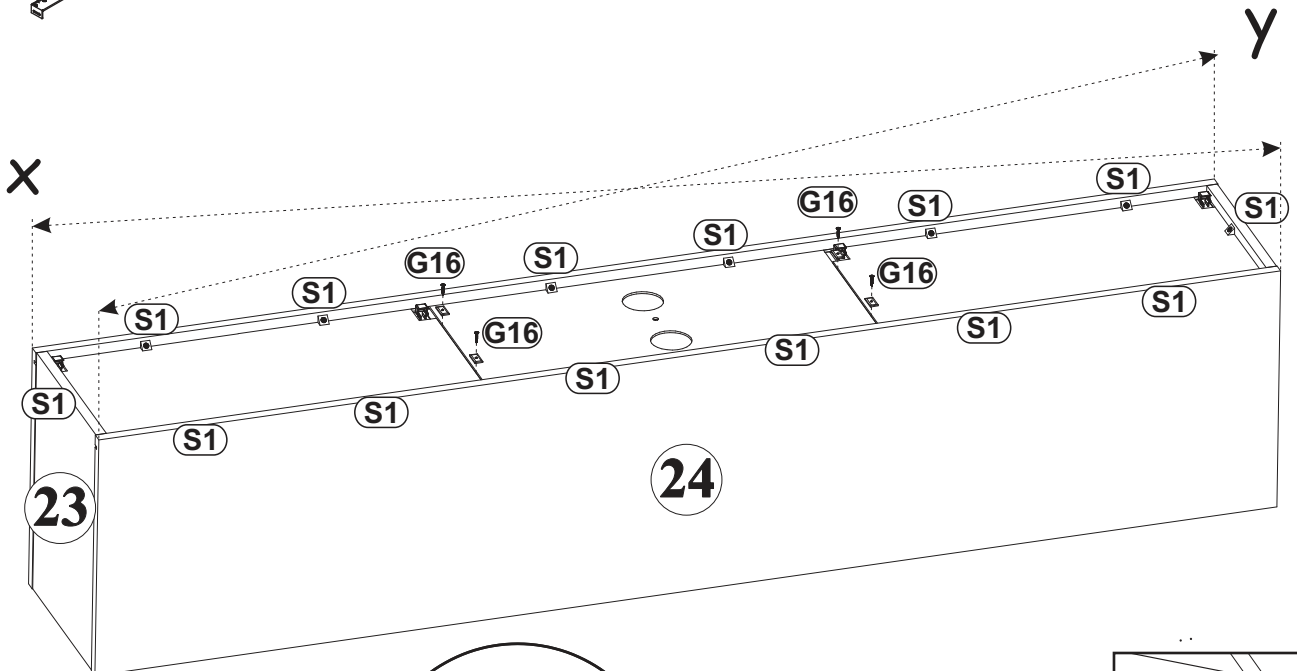

26

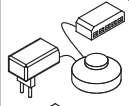
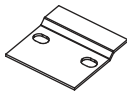
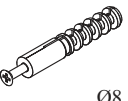
LED		SZ7		KR1	
x1	1x2	x4		X8	Ø8

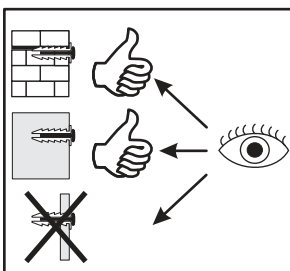
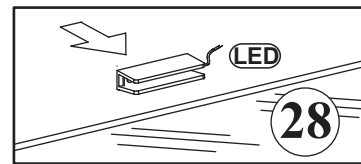
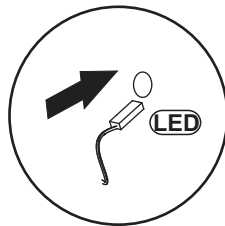
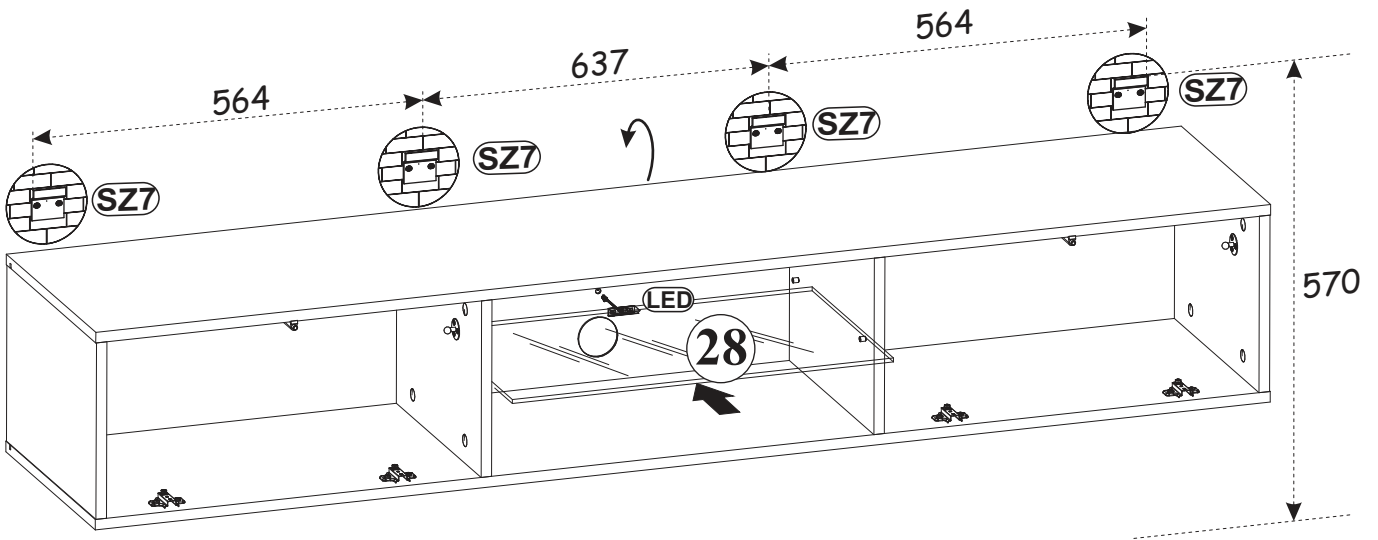
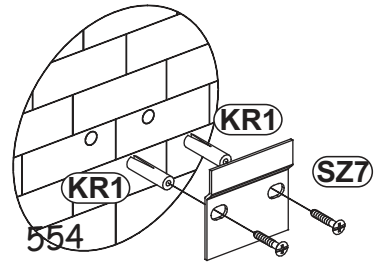
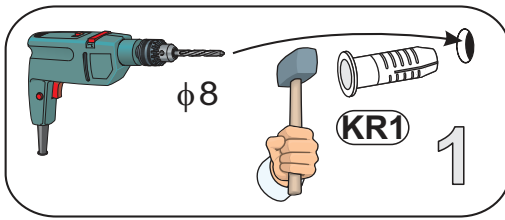

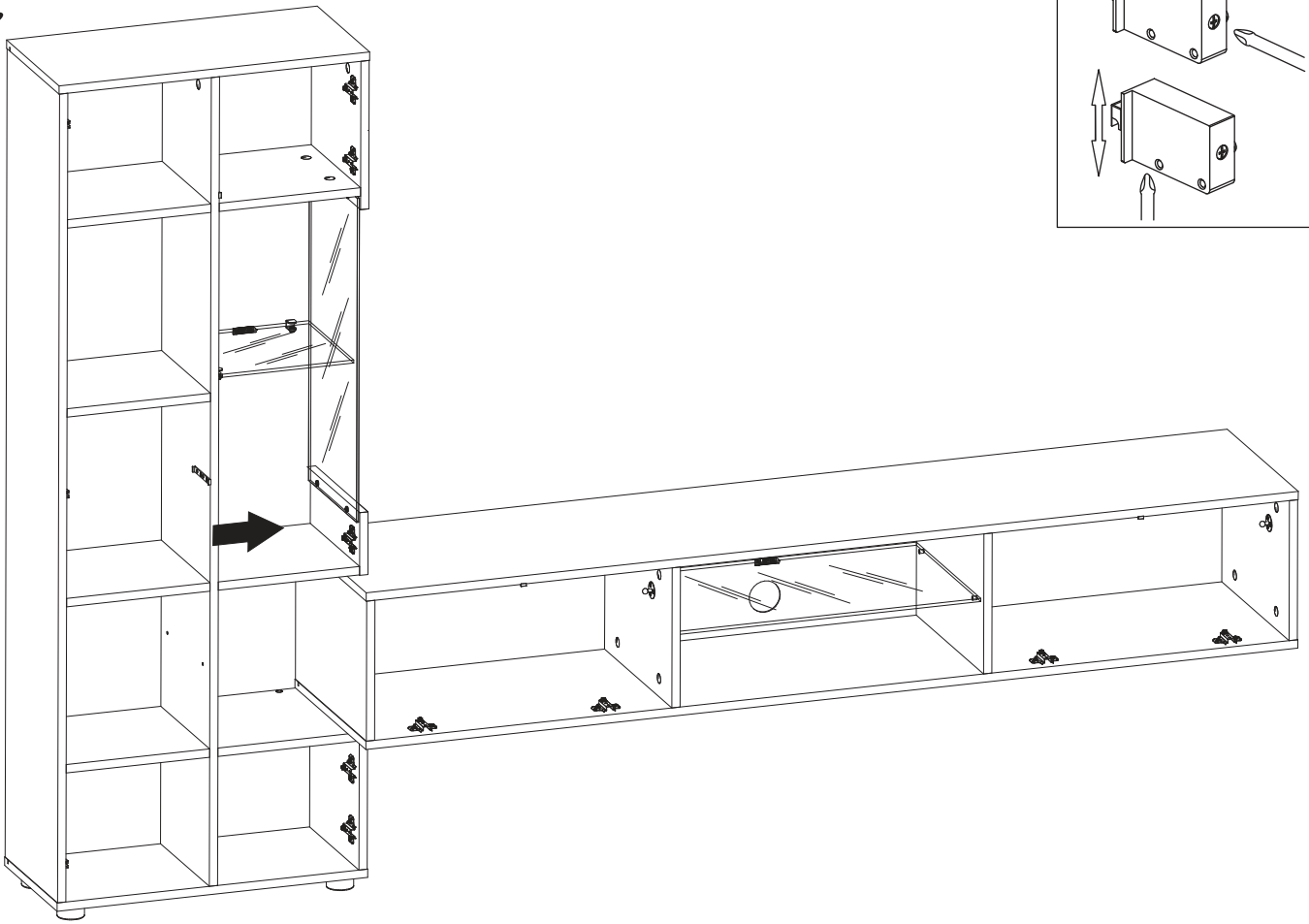

27

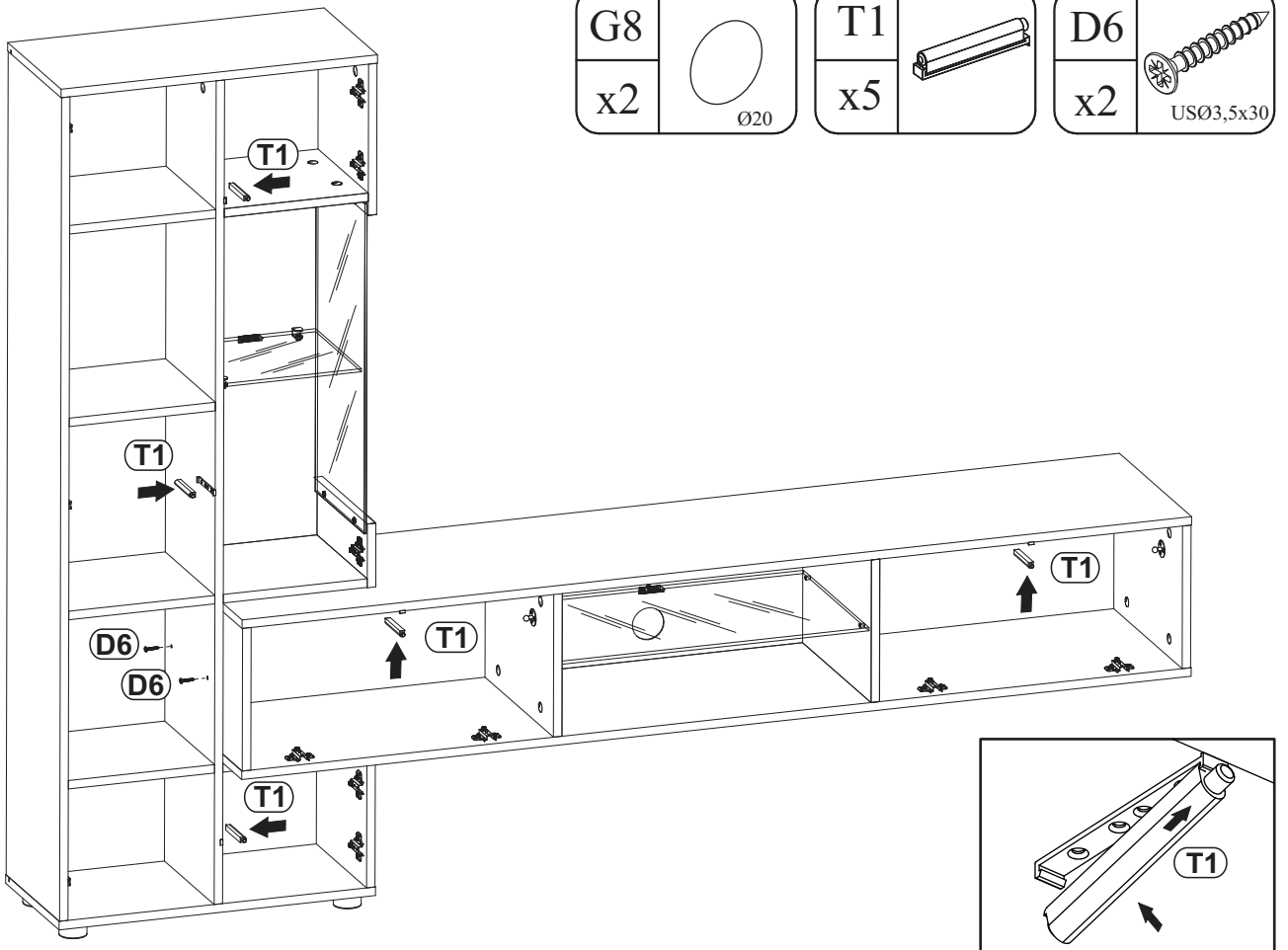

28

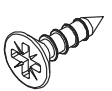
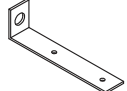

29

D10		L1		KR1	
x2	USØ3,5x13	x1		x1	

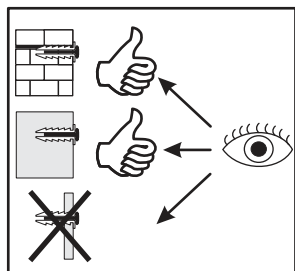
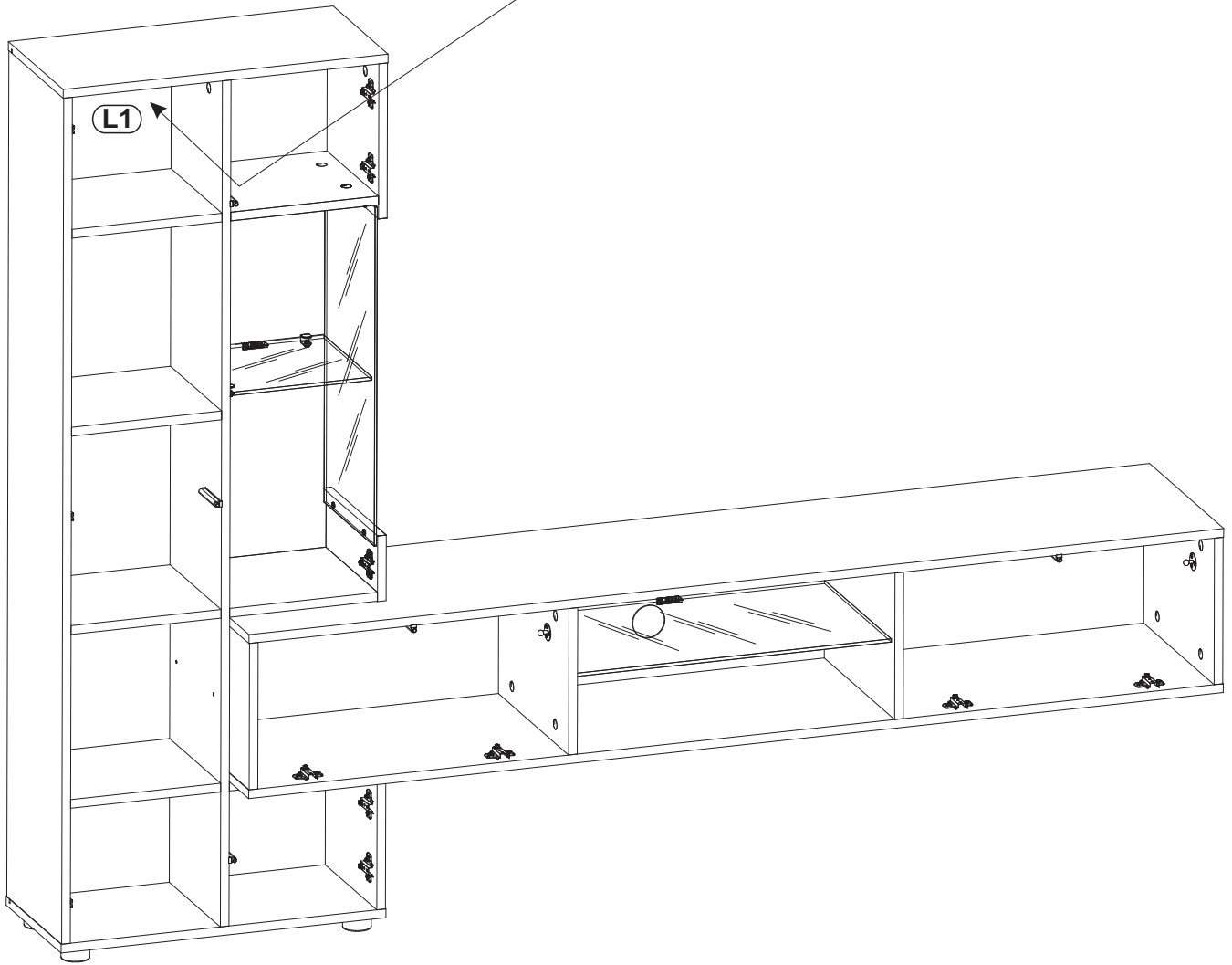
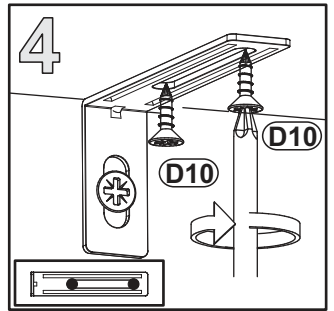
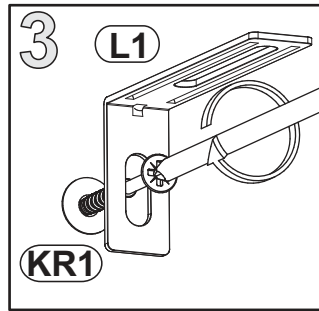
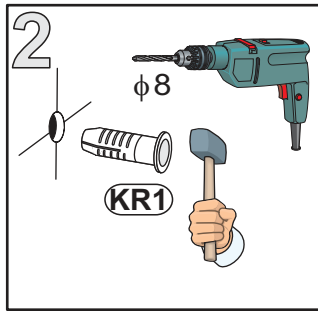
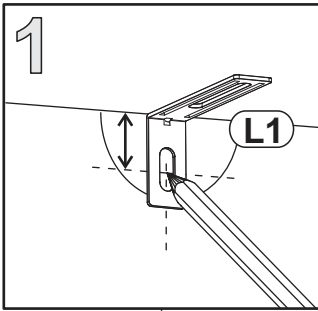

30

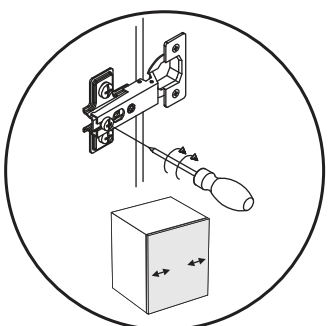
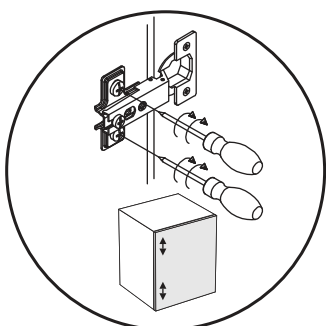
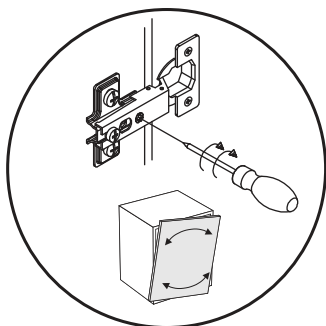
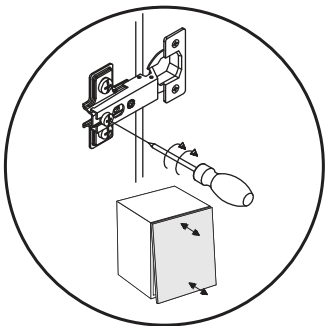
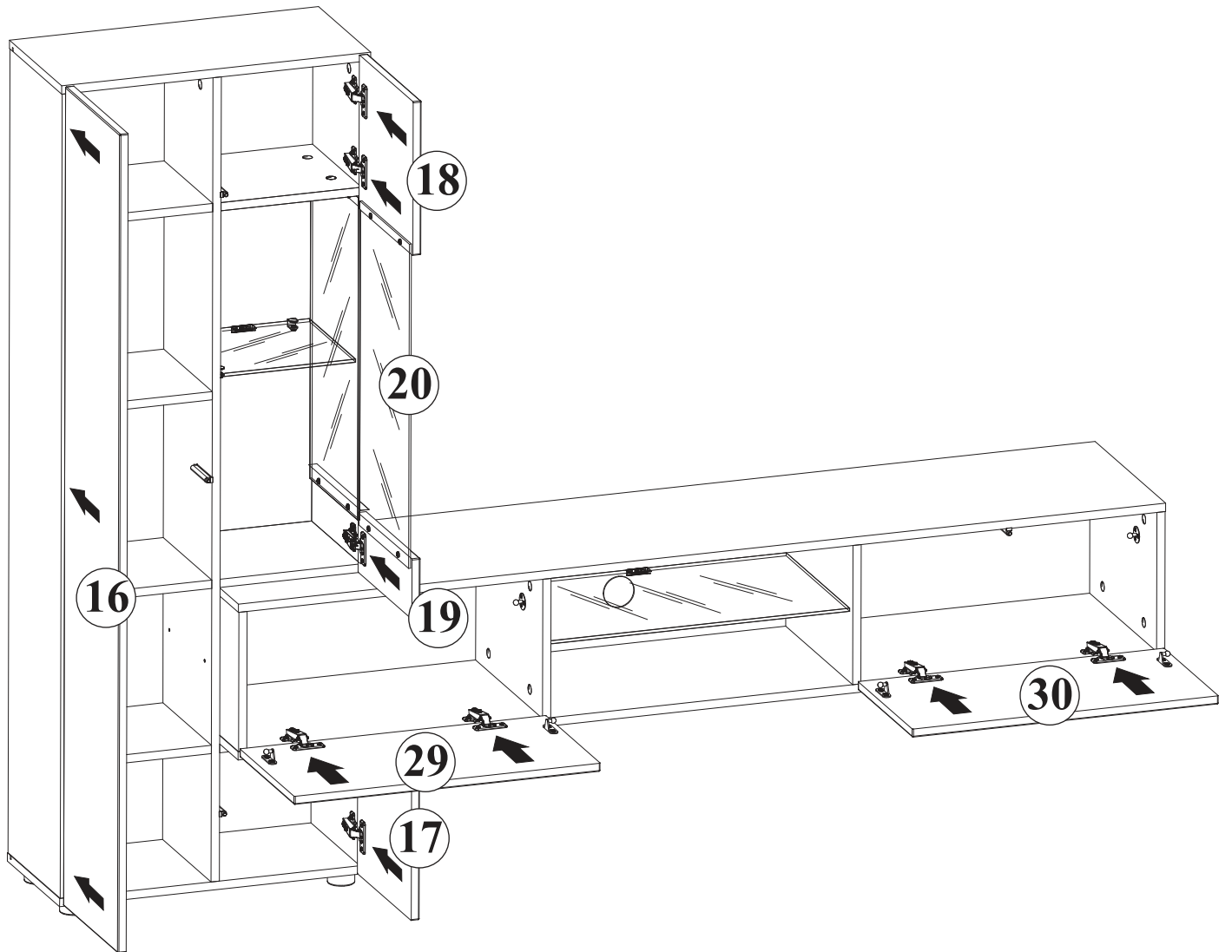

31

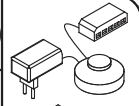
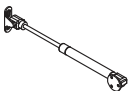
LED		BO1	
x1	1x2	x4	

