

Assembly Instructions

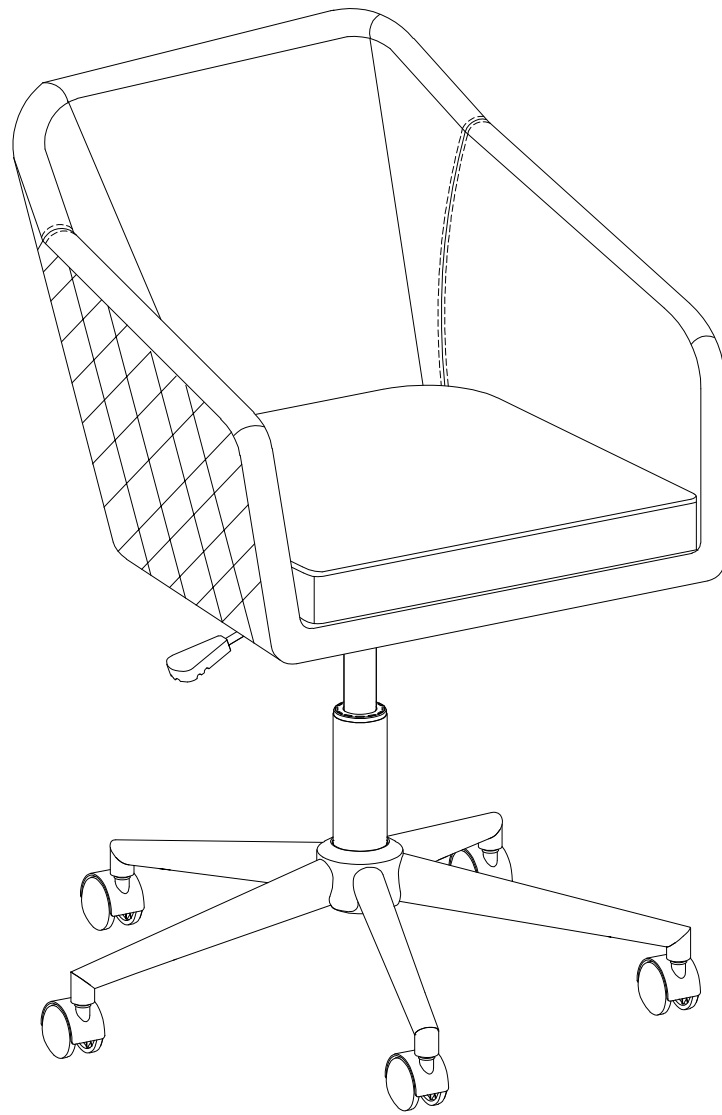

General Assembly Guidelines

- I. Ensure that all parts and hardware are available before beginning assembly.
- II. Follow each step carefully to ensure the proper assembly of this product.
- III. Two people are recommended for ease in the assembly of this product.
- IV. The main type of hardware used to assemble this product are: bolts and screws.
- V. Power tools should not be used to assemble this product.

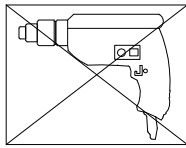

- VI. Drill may be needed for securing product to wall.

Parts List

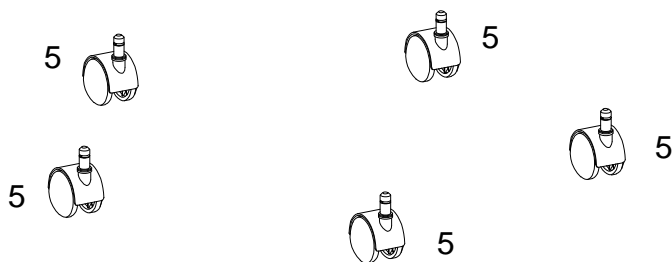
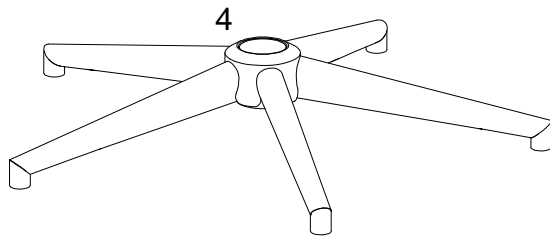
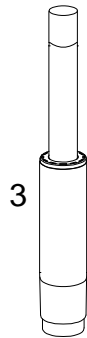
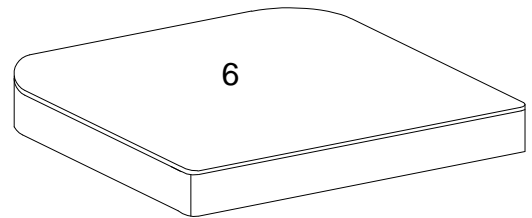
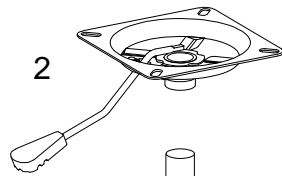
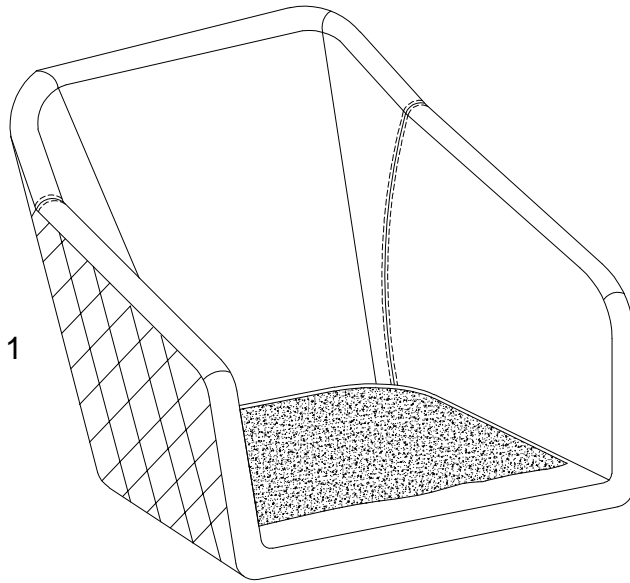

Hardware List

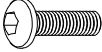
A			Flat washer	4	pcs
B			Lock washer	4	pcs
C		M6x18mm	Bolt	4	pcs
D		M 5	Hex Key	1	pc

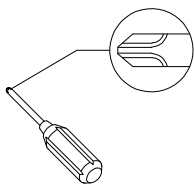

Philips head screwdriver required for assembly
(not included)

*The hardware quantities listed above are required for proper assembly.
Some extra hardware may also have been included.*

Step 1

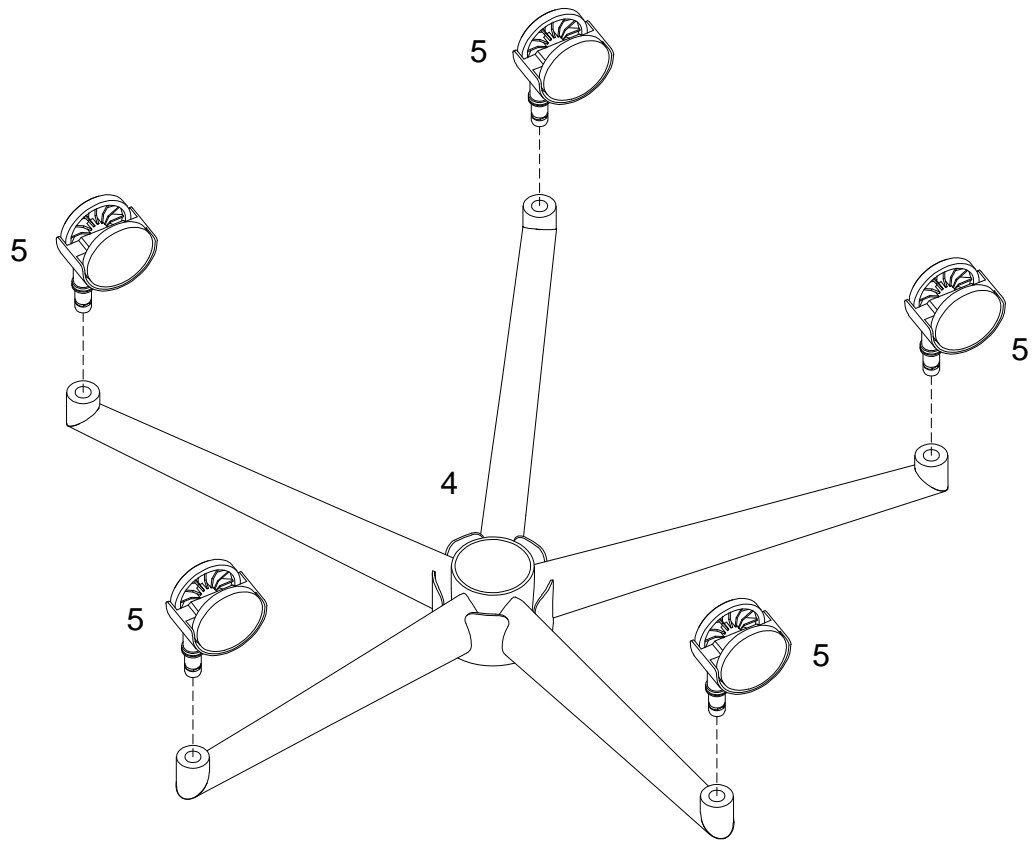

Place parts (5) to the bottom of part (4) as per diagram.

Step 2

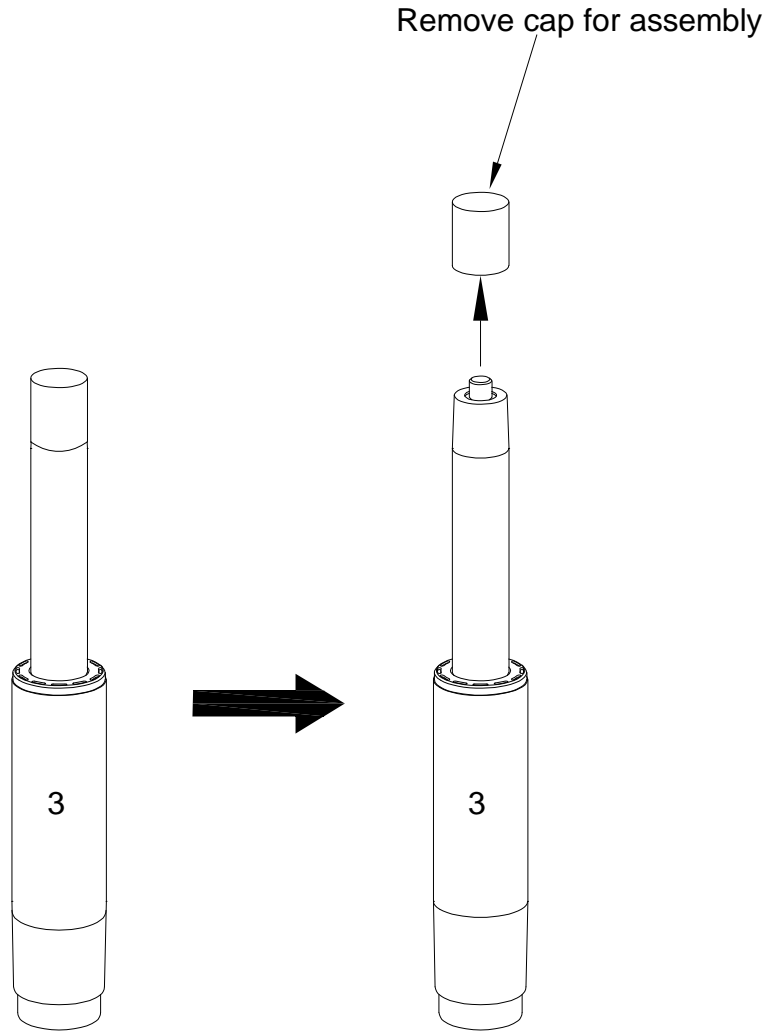

Remove cap at the top of part (3) as per diagram.

Step 3

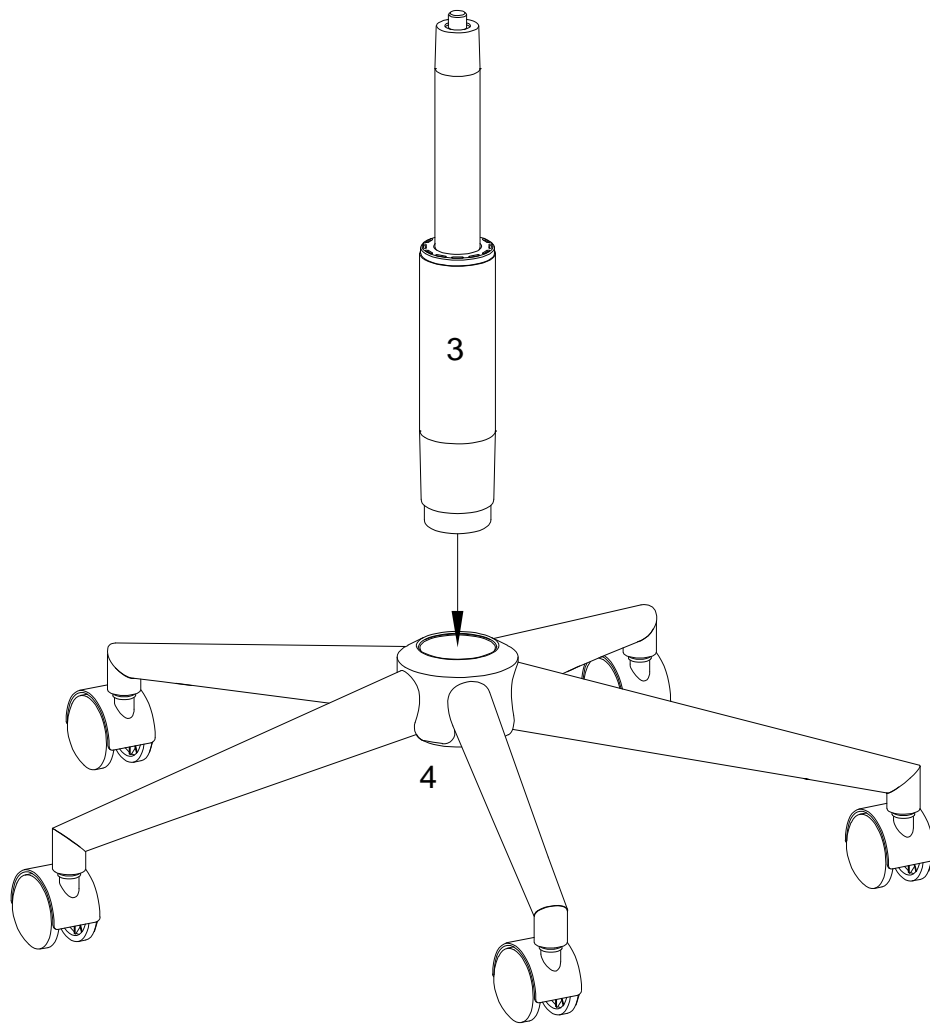

Insert part (3) into part (4) as per diagram.

Step 4

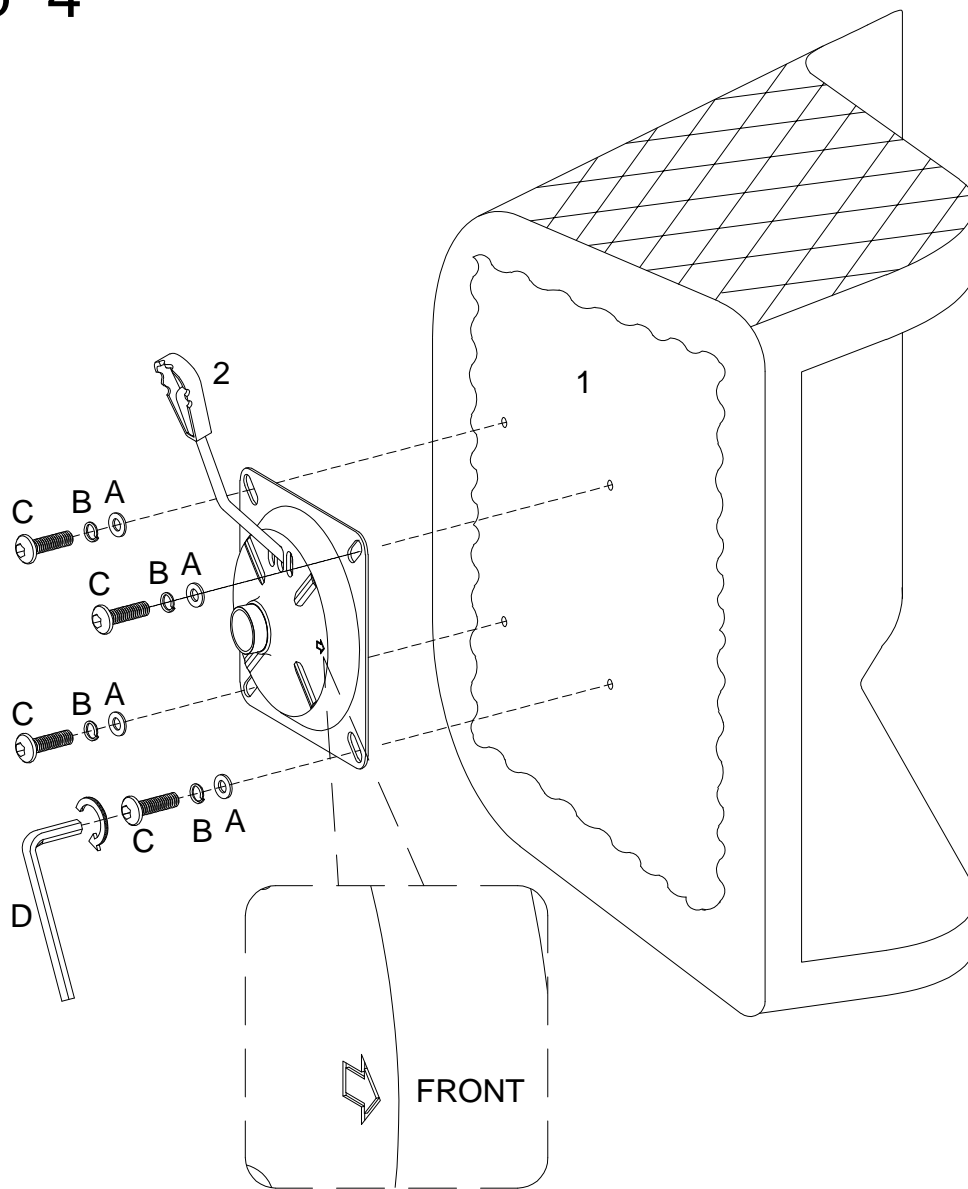

Using bolt (C) insert Lock washer (B) ,Flat Washer (A) into part (2) to part (1) with Hex Key (D) as per diagram.

Step 5

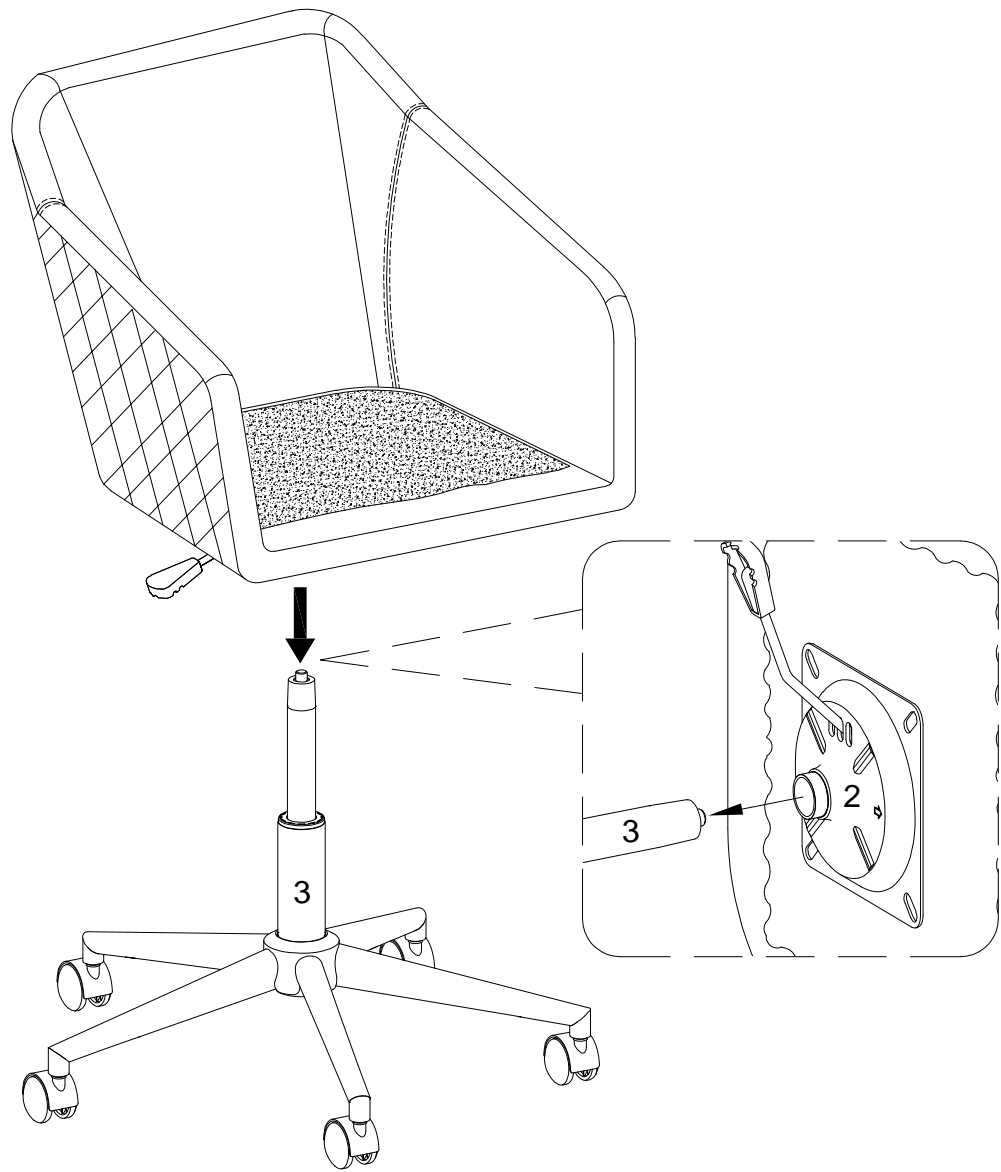

Put part (2) cover the top of part (3) as per diagram.

Step 6

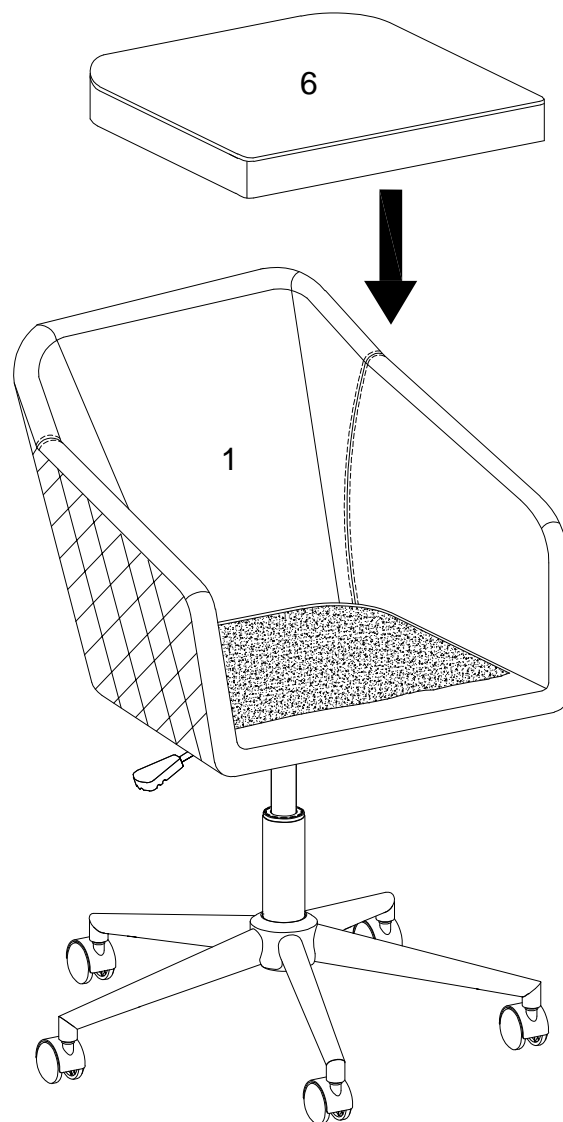

Put part (6) to part (1) as per diagram.

Step 7

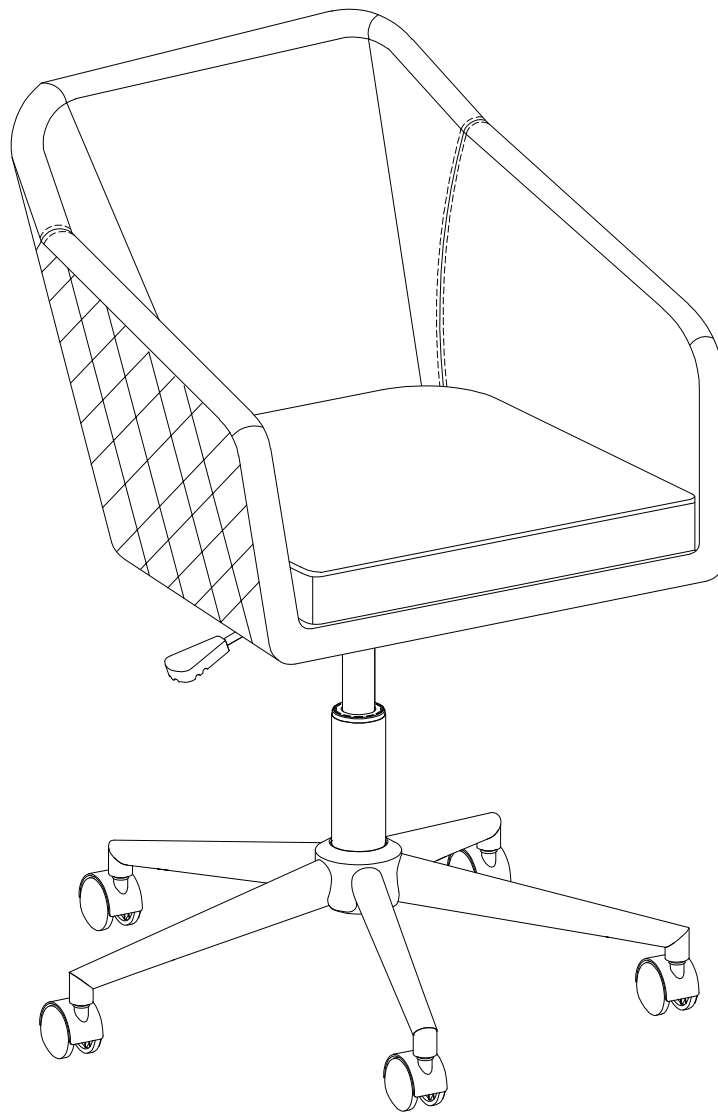

Final Assembly