

Installation & Assembly

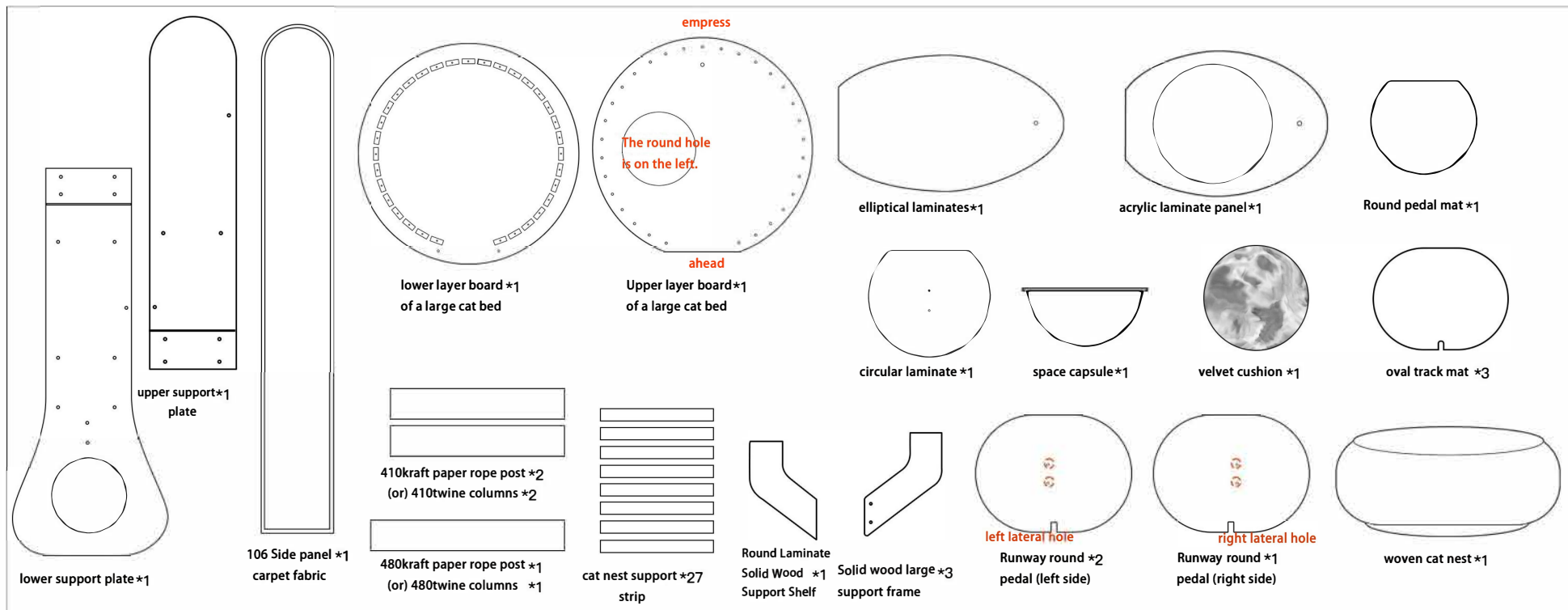

List of panels



Hardware list

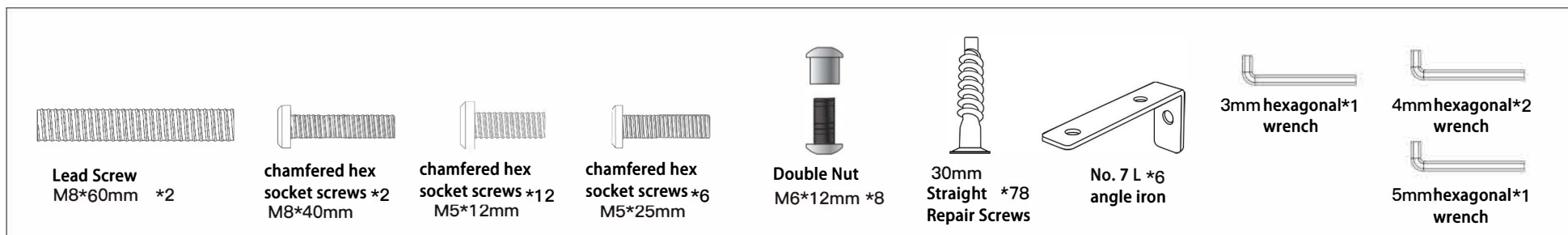

Installation steps

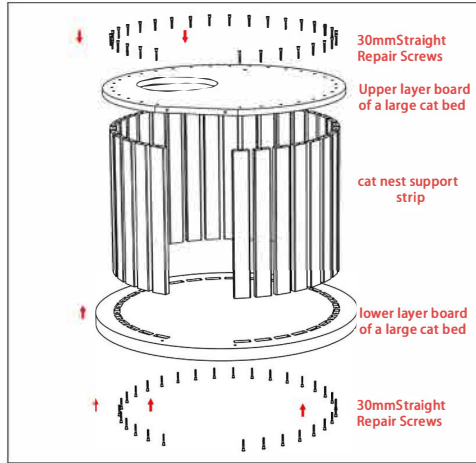

1. Insert the support strips of the cat nest into the lower slots.
2. Use 30mm straight repair screws to secure the support strip to the lower panel, and apply the same method to the other support strips.
3. Align the support strips with the slots on the upper panel, then use 30mm straight repair screws to secure the upper panel to the support strips.

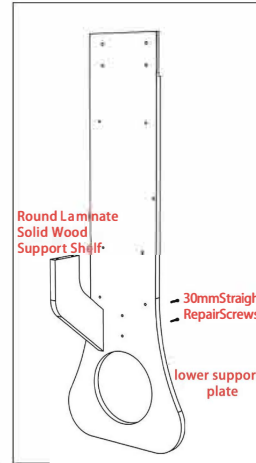

Use 30mm straight repair screws to secure the support frame to the lower support panel.

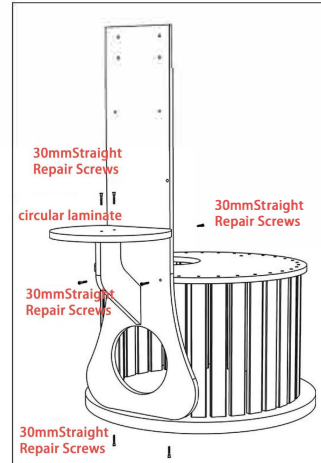

1. Use 30mm straight repair screws to secure the lower support panel to both the lower and upper panels.
2. Use 30mm straight repair screws to secure the circular panel to the support frame.

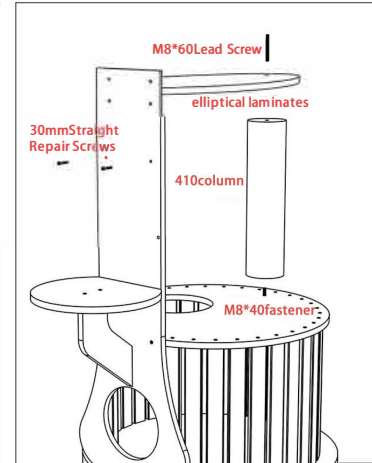

1. Use M8 x 40mm screws to secure the 410 post to the upper panel of the cat house (as shown above).
2. Use 30mm straight repair screws to secure the oval panel to the lower support panel.
3. Use M8 x 60mm threaded rods to secure the oval panel to the 410 paper column.

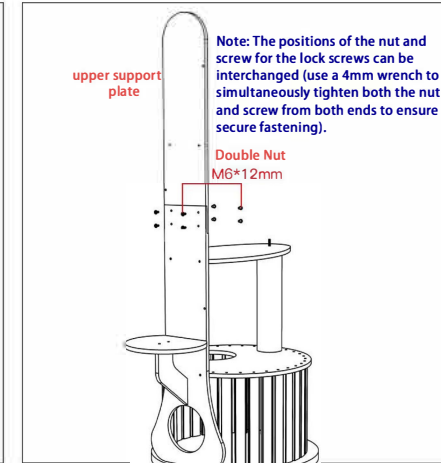

Use M6 x 12mm counter-sunk screws (or "locking screws" if contextually appropriate) to securely fasten the upper support plate to the lower support plate.
(Use a 4mm wrench to simultaneously secure the nut and bolt (or screw) from both the front and rear, then tighten firmly.)

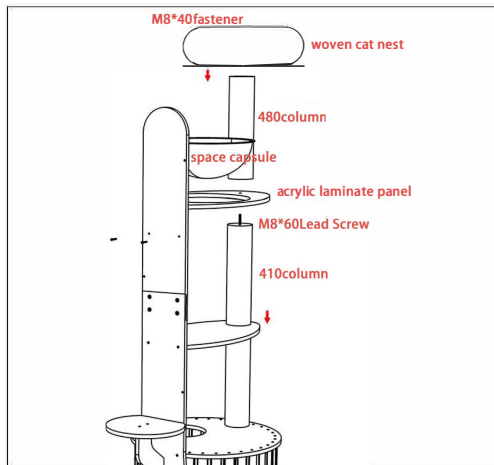

1. Secure the 410 paper column to the elliptical board using a threaded rod.
2. Secure the acrylic panel to the lower support board using 30mm self-tapping screws.
3. Secure the acrylic panel to the 410 column using an M8 x 60mm threaded rod.
4. Secure 480 pillars to the acrylic shelf using threaded rods.
5. Fasten the woven cat bed to the 480 pillars using M8 x 40mm screws.

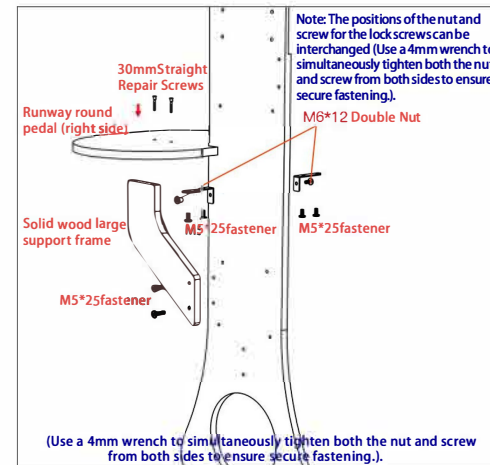

1. Secure the large support bracket to the lower support plate using M5 x 25mm screws.
2. Secure two No. 7 L-brackets to the lower support plate using M6 x 12mm lock screws.
3. Secure the circular track pedal to the large support bracket using 30mm self-tapping screws, then, fasten the circular track pedal to the No. 6 L-bracket using M5 x 12mm screws.
4. Secure the remaining circular track pedals following the same procedure described above.

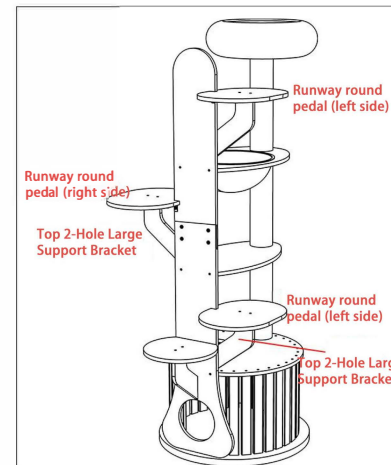

Install the circular track pedal following the same method as the previous step.

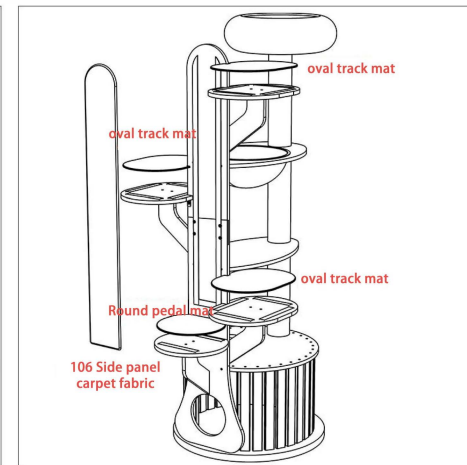

As shown in the figure above