

## SAFETY INFORMATION



Please read and understand this entire manual before attempting to assemble, operate or install the product.



### WARNING

- Some steps are more easily handled with two adults.

### CAUTION

- Before assembly and/or installation, carefully unwrap all parts.
- Locate and set aside the hardware kit before discarding packaging.
- Use care when assembling your new product. Take your time and follow assembly instructions closely.

## INFORMATION DE SÉCURITÉ



Assurez-vous de lire et de comprendre l'intégralité du présent manuel avant de tenter d'assembler, d'utiliser ou d'installer le produit.



### AVERTISSEMENT

- Certaines étapes sont plus faciles à effectuer avec l'aide.

### MISE EN GARDE

- Avant l'assemblage et/ou l'installation, vous devez déballer minutieusement toutes les pièces.
- Localisez et mettez de côté le jeu de quincaillerie avant de jeter l'emballage.
- Soyez vigilant lorsque vous assemblez le nouveau produit. Prenez votre temps et suivez attentivement ces instructions.

## INFORMACIÓN DE SEGURIDAD



Lea y comprenda completamente este manual antes de intentar ensamblar, usar o instalar el producto.



### ADVERTENCIA

- Algunos de los pasos se pueden realizar con mayor facilidad entre dos adultos.

### PRECAUCIÓN

- Antes del ensamblaje y/o instalación, desenvuelva cuidadosamente todas las piezas.
- Localice y separe el equipo de accesorios antes de desechar el embalaje.
- Tenga cuidado al ensamblar el nuevo producto. Tómese su tiempo y siga detenidamente las instrucciones de ensamblaje.

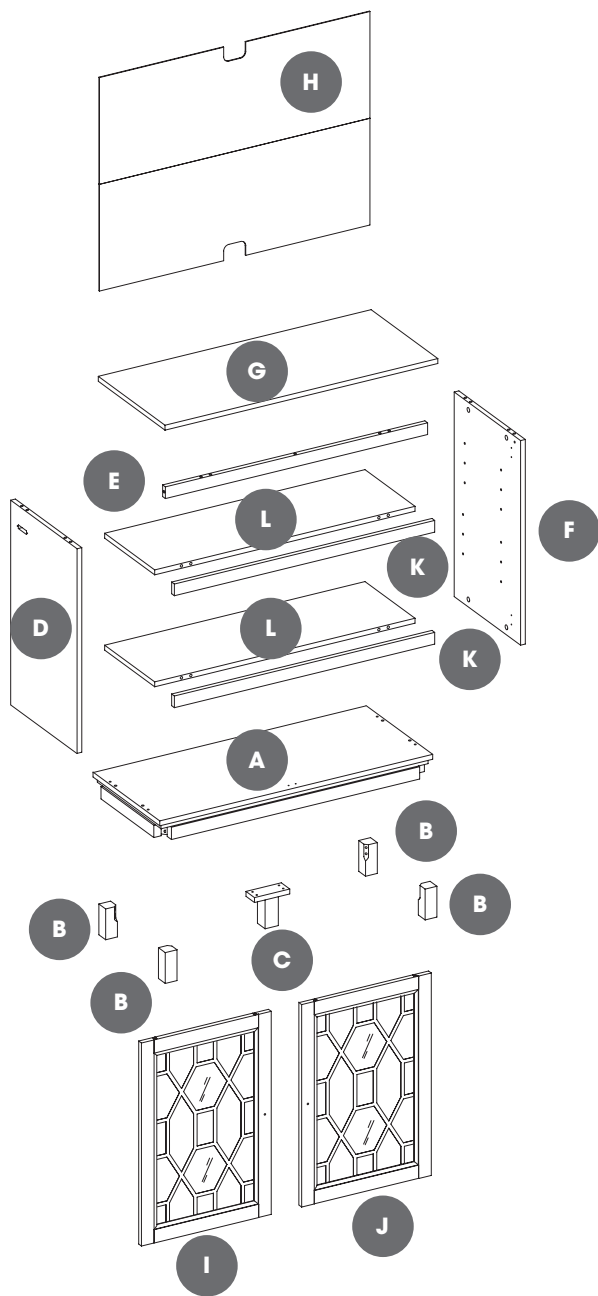

**MAXIMUM LOAD**  
20.4 kg / 45 lb  
**CHARGE MAXIMALE DE**  
20.4 kg / 45 lb  
**CARGA MÁXIMA**  
20.4 kg / 45 lb

**MAXIMUM LOAD**  
20.4 kg / 45 lb  
**CHARGE MAXIMALE DE**  
20.4 kg / 45 lb  
**CARGA MÁXIMA**  
20.4 kg / 45 lb

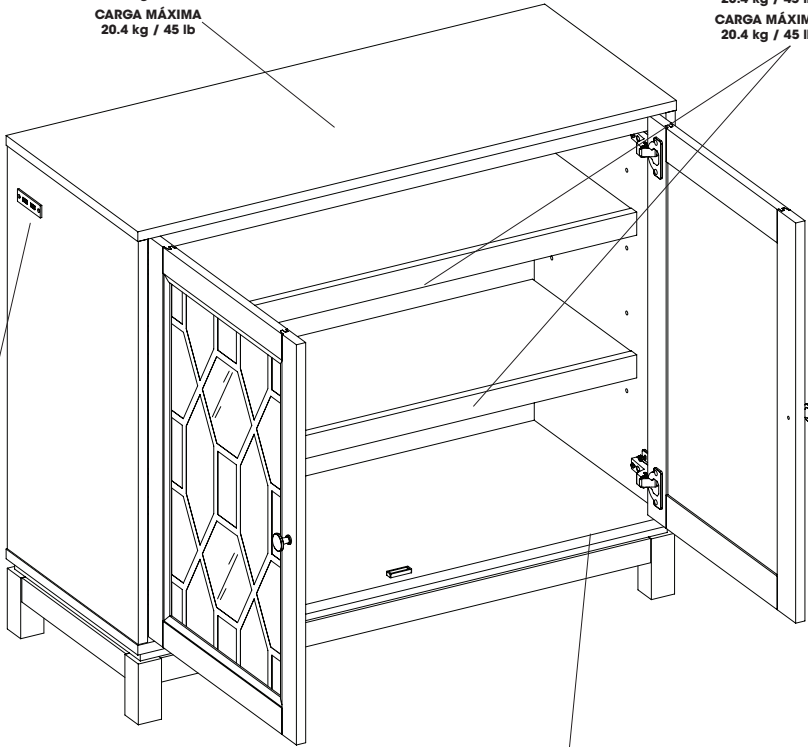

To power this item, plug USB cable into a USB outlet or AC power adapter. AC power adapter (100-240V, 0.3A; output: 5V/2.1A) not included.

Para dar alimentación eléctrica a este elemento, conecte el cable USB a una salida de USB o adaptador de alimentación de CA. Adaptador de alimentación de CA (100-240 V, 0,3 A; salida: 5 V/2,1 A) no incluido.

Pour alimenter cet appareil, branchez le câble USB dans une prise USB ou un adaptateur secteur. Adaptateur secteur (100-240 V, 0,3 A; sortie : 5 V/2,1 A) non inclus.

**MAXIMUM LOAD**  
22.7 kg / 50 lb  
**CHARGE MAXIMALE DE**  
22.7 kg / 50 lb  
**CARGA MÁXIMA**  
22.7 kg / 50 lb



### **WARNING**

Loads heavier than the maximum weights specified may result in instability causing tip over resulting in death or serious injury.

### **ATTENTION**

Des charges dont le poids dépasse les valeurs spécifiées peut entraîner l'instabilité et le basculement pouvant provoquer la mort ou des blessures graves.

### **PRECAUCIÓN**

Cargas mayores que los pesos máximos especificados puede generar inestabilidad y, en consecuencia, desplomes que pueden causar la muerte o lesiones graves.

AA

[x8]

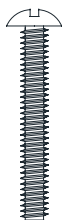

Ø6.3x50mm  
PH-BLTBLK014

BB

[x8]



Ø16mm  
PH-WSRZNC002

CC

[x4]



Ø4 x25mm  
PH-SCRBLK018

DD

[x2]



PH-BMPBLK002

EE

[x4]

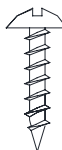

Ø3x15mm  
PH-SCRBLK010

FF

[x1]

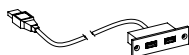

GG

[x2]



Ø3x12mm  
PH-SCRBLK004

HH

[x19]



PH-KDBZNC001

II

[x14]



Ø8x30mm  
PH-DWLNTL001

JJ

[x19]



PH-KDCZNC001

KK

[x20]

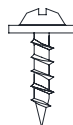

Ø3x12mm  
PH-SCRBLK007

LL

[x3]



PH-WMCWHT003

MM

[x3]

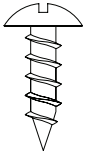

Ø3.5x12mm  
PH-SCRBLK013

NN

[x8]



PH-KDPXXX001

OO

[x4]



PH-HNG2H35CR95

PP

[x8]



Ø3.5x15mm  
PH-SCRBLK008

QQ

[x2]



A4229

RR

[x8]

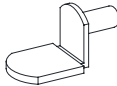

PH-SPNPCSPLB2

SS

[x1]

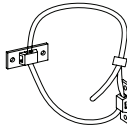

PH-BKTWHT003

## HARDWARE/QUINCAILLERIE/FERRETERÍA

**ATTENTION:** Follow instructions in the order they are given below. This will ensure that your product is properly assembled.

**ATTENTION :** Suivre les instructions dans l'ordre donné ci-dessous. Cela vous assurera d'assembler correctement le produit.

**ATENCIÓN:** Siga las instrucciones en el orden que se indica a continuación. Esto asegurará que su producto se ensamble correctamente.

1

AA  [x8]

BB  [x8]

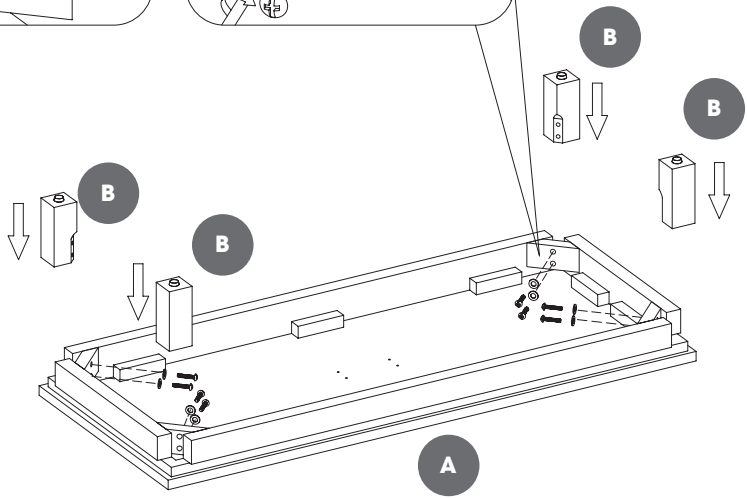
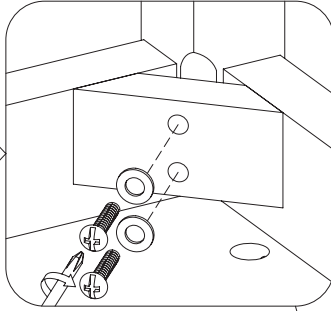
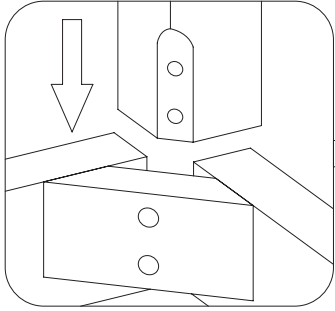

2

CC



[x4]

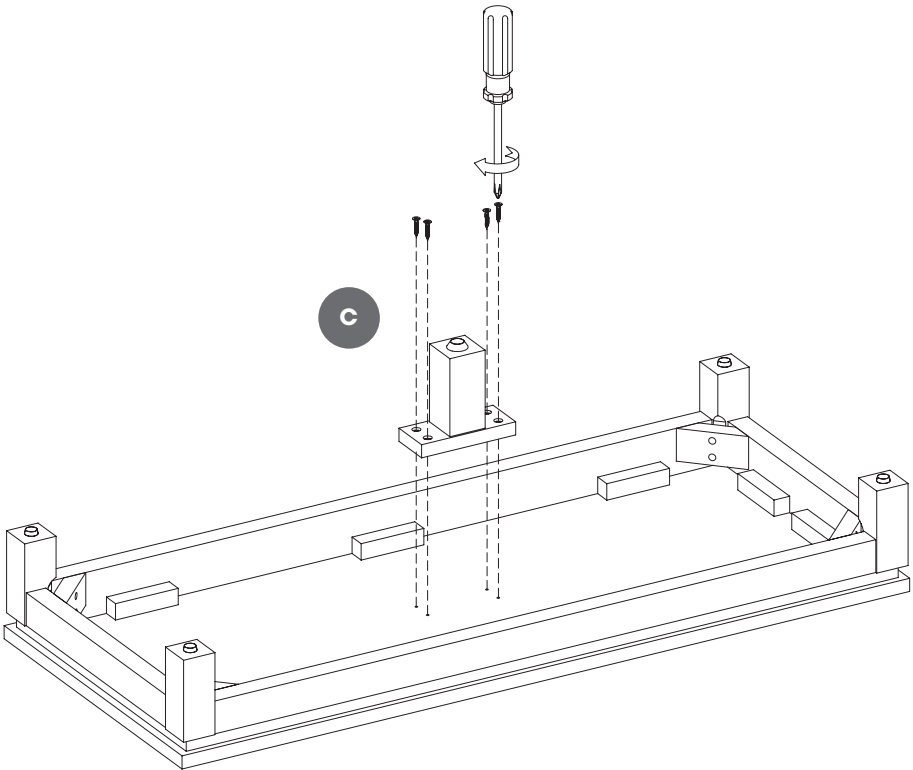

**3**

**DD**

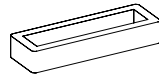

**[x1]**

**EE**

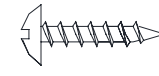

**[x2]**

**HH**

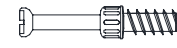

**[x4]**

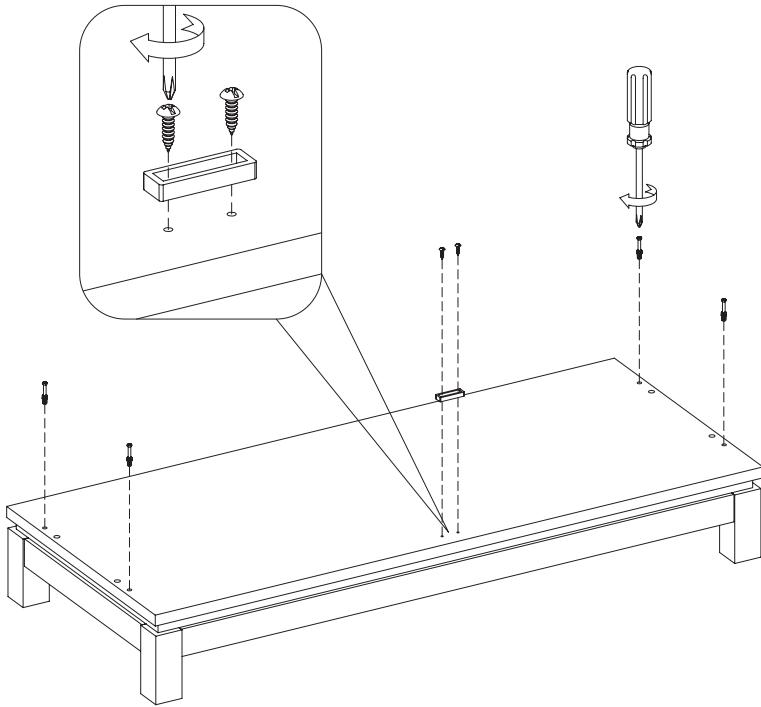

4

FF

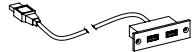

[x1]

GG

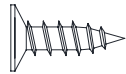

[x2]

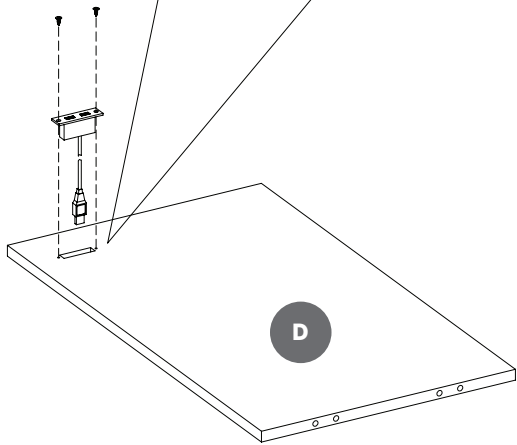
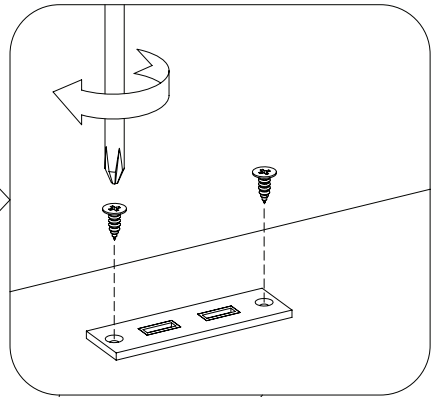
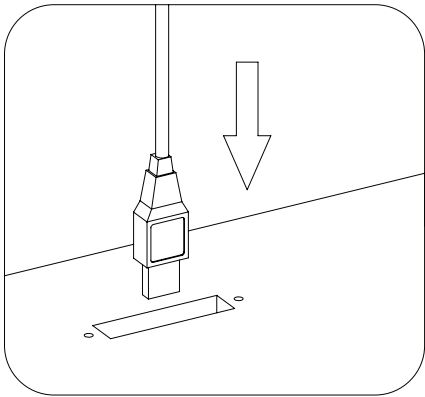

5

- HH [x2]
- II [x4]

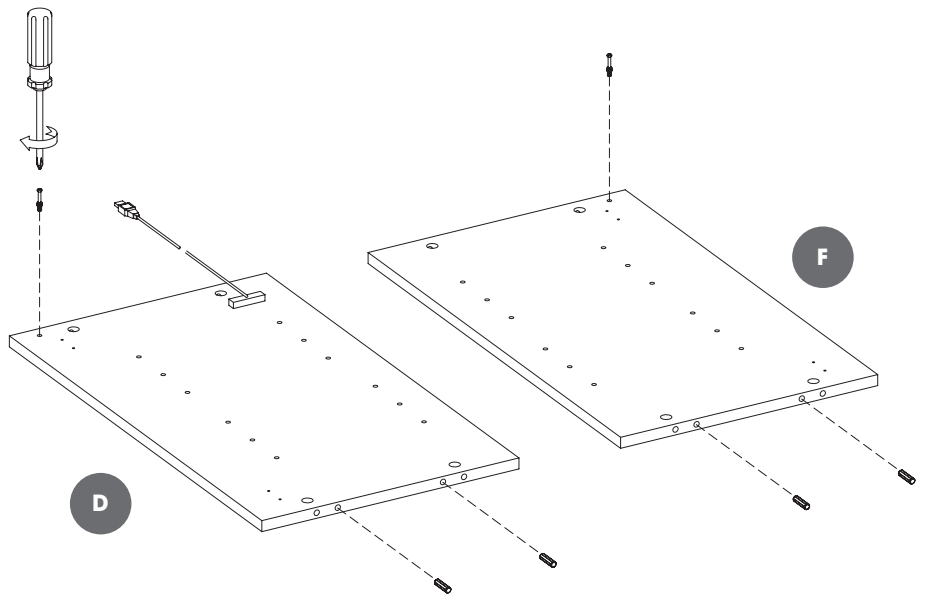

6

JJ



[x2]

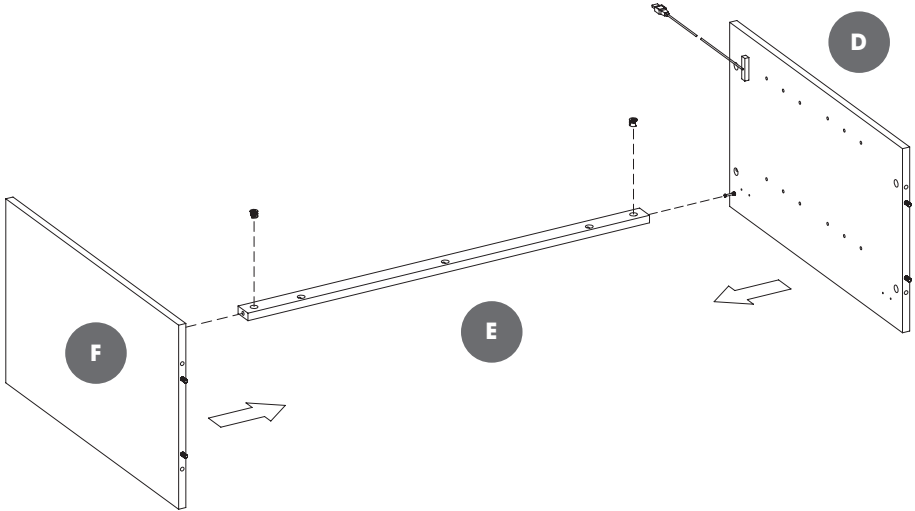
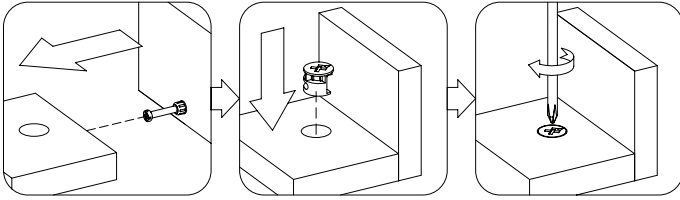

7

JJ



[x4]

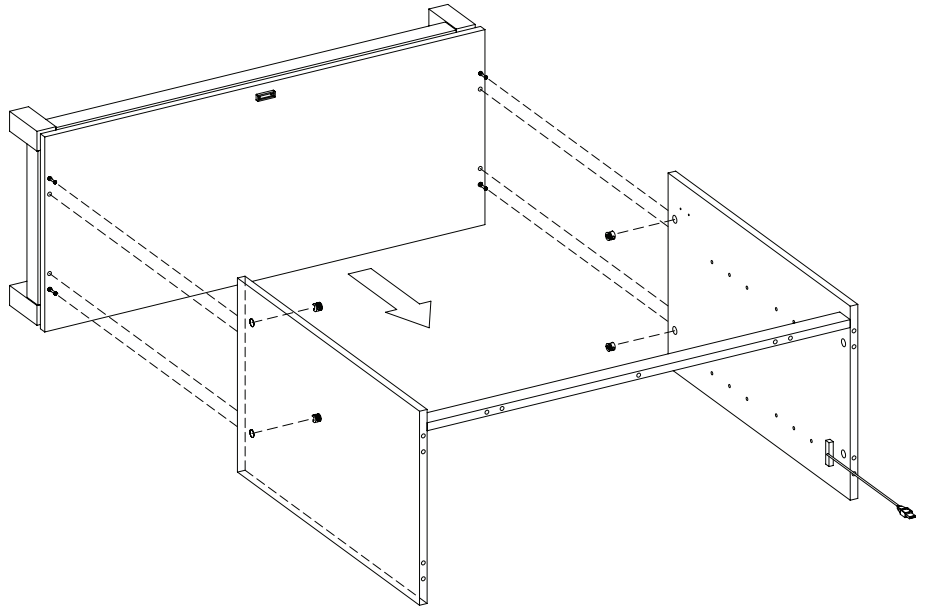
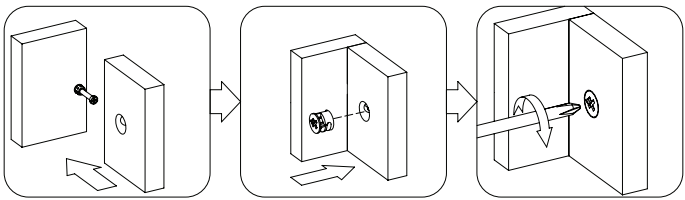

8

||



[x6]

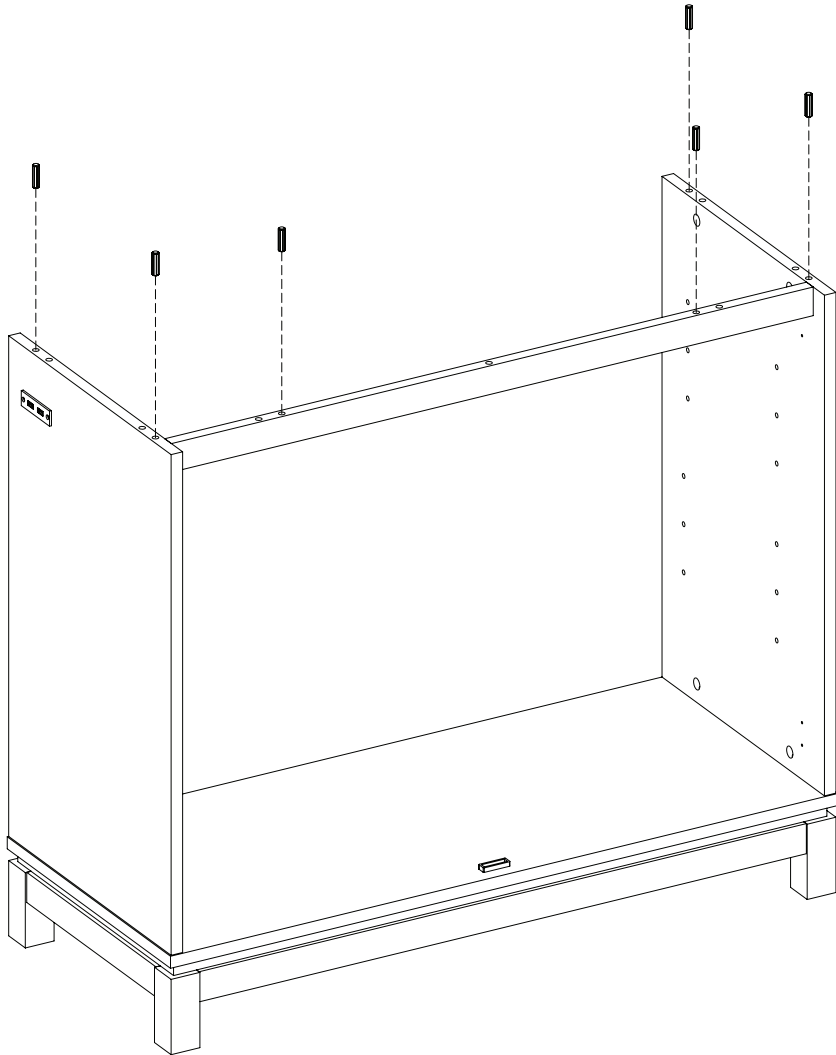

9

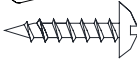
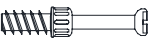
- DD  [x1]
- EE  [x2]
- HH  [x7]

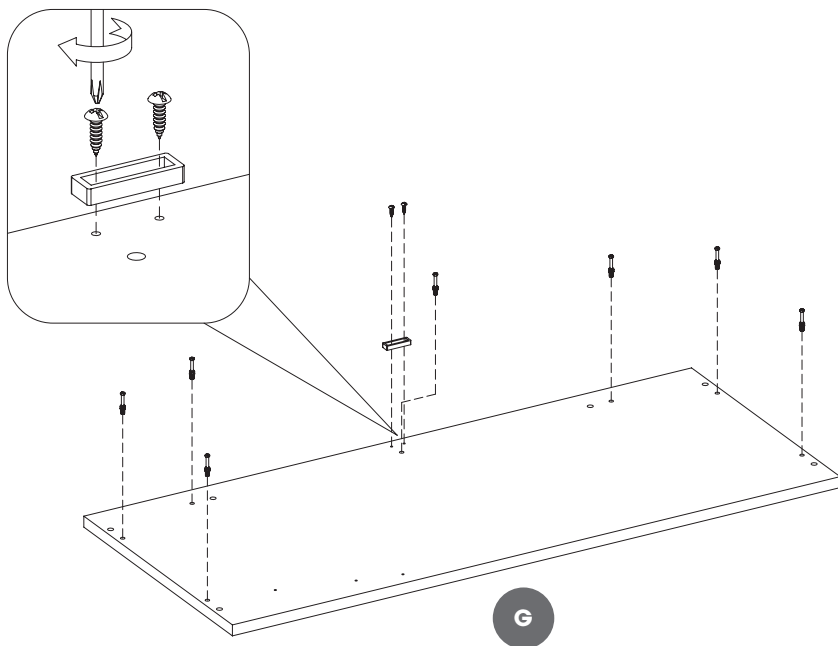

10

JJ



[x7]

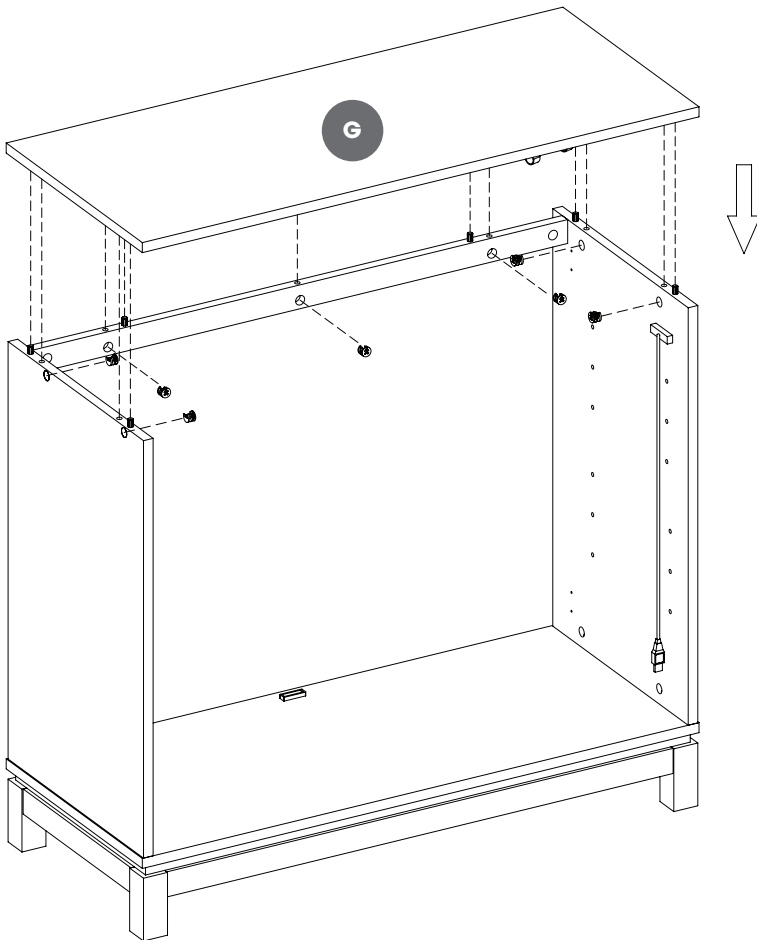
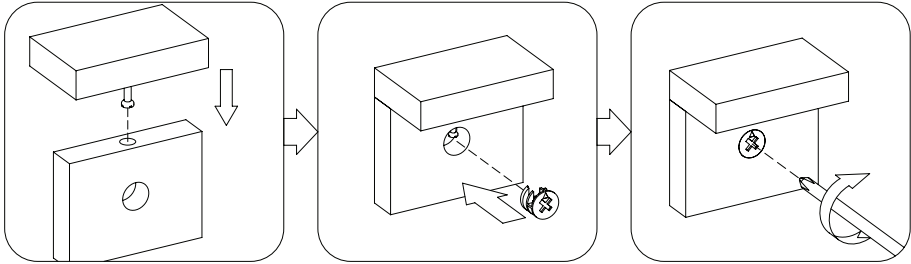

11

KK

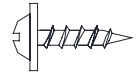

[x2]

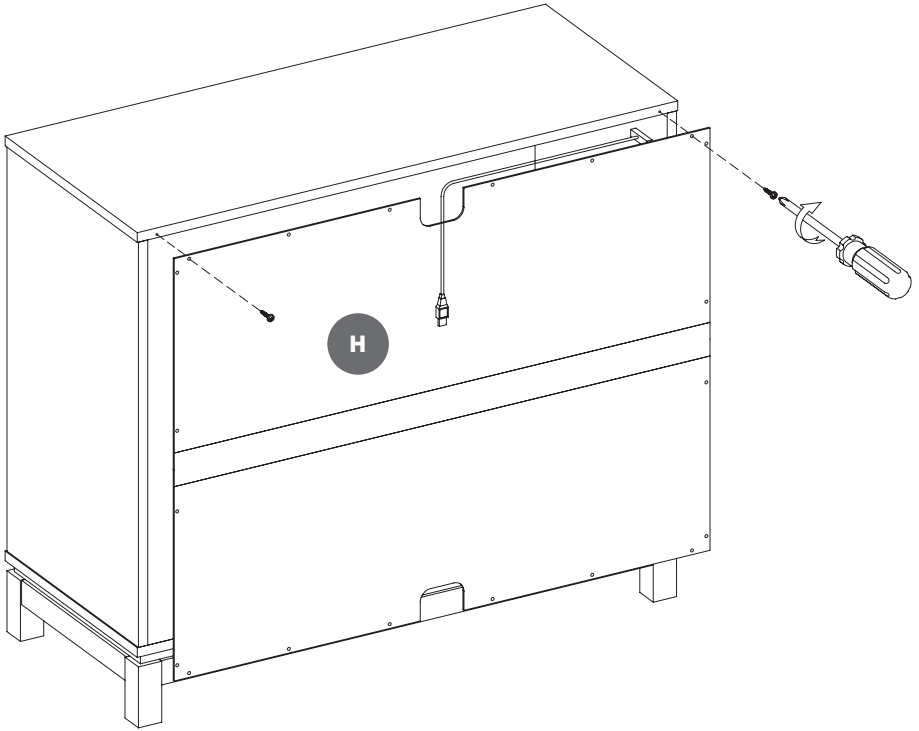

12

KK

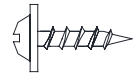

[x18]

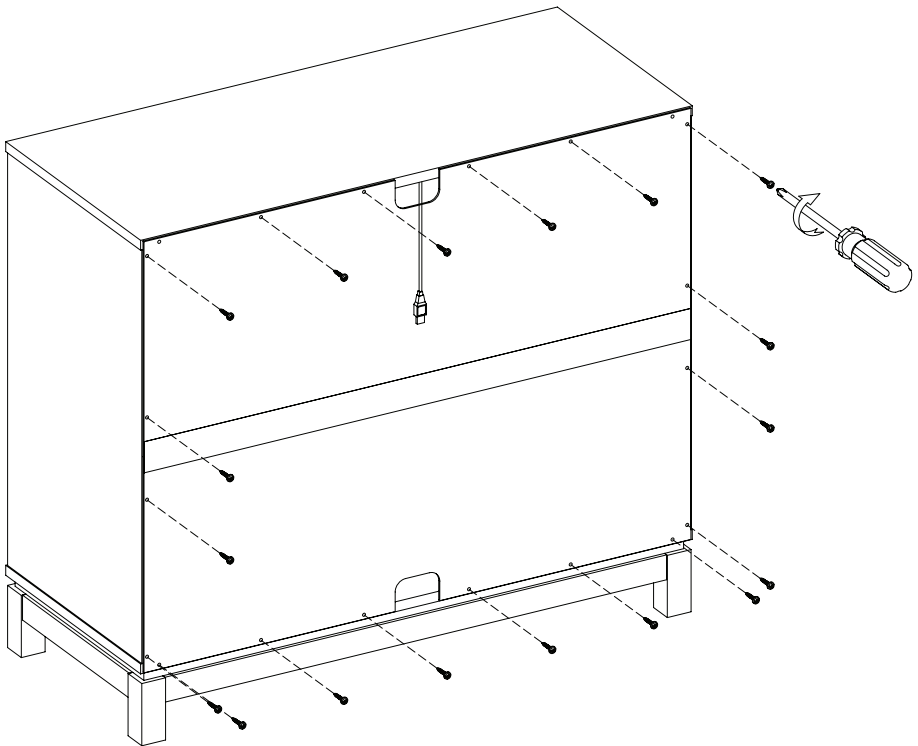

13

LL



[x3]

MM

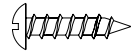

[x3]

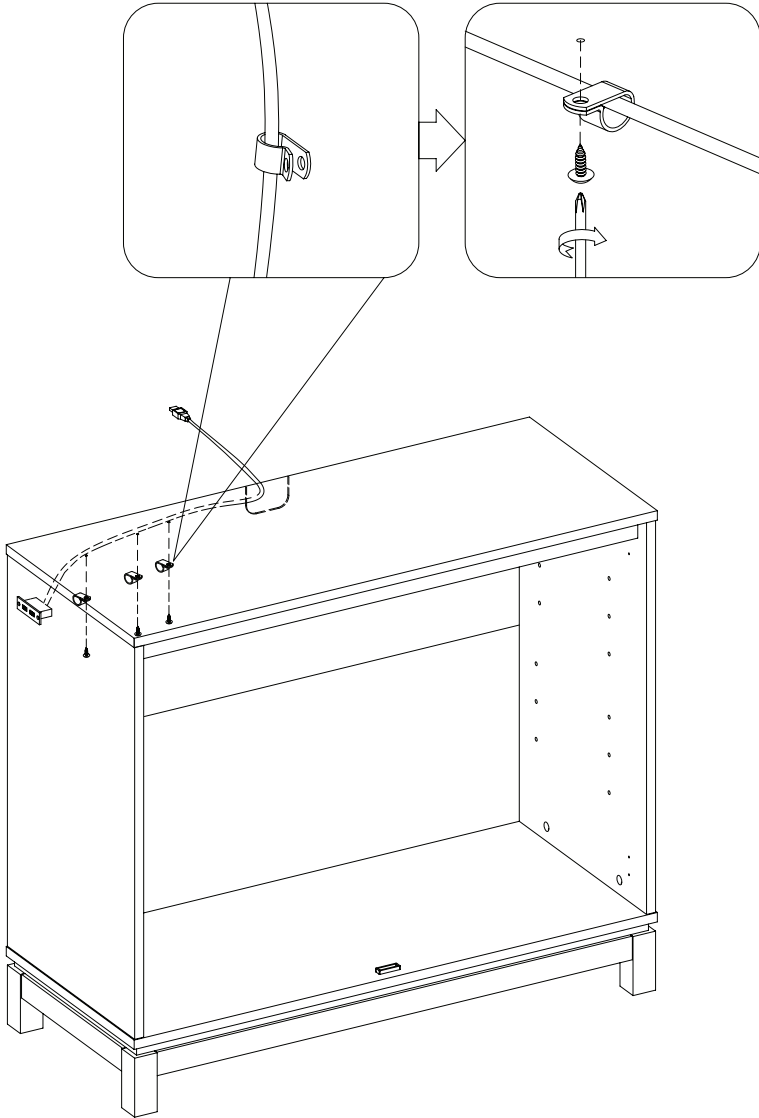

14

NN



[x8]

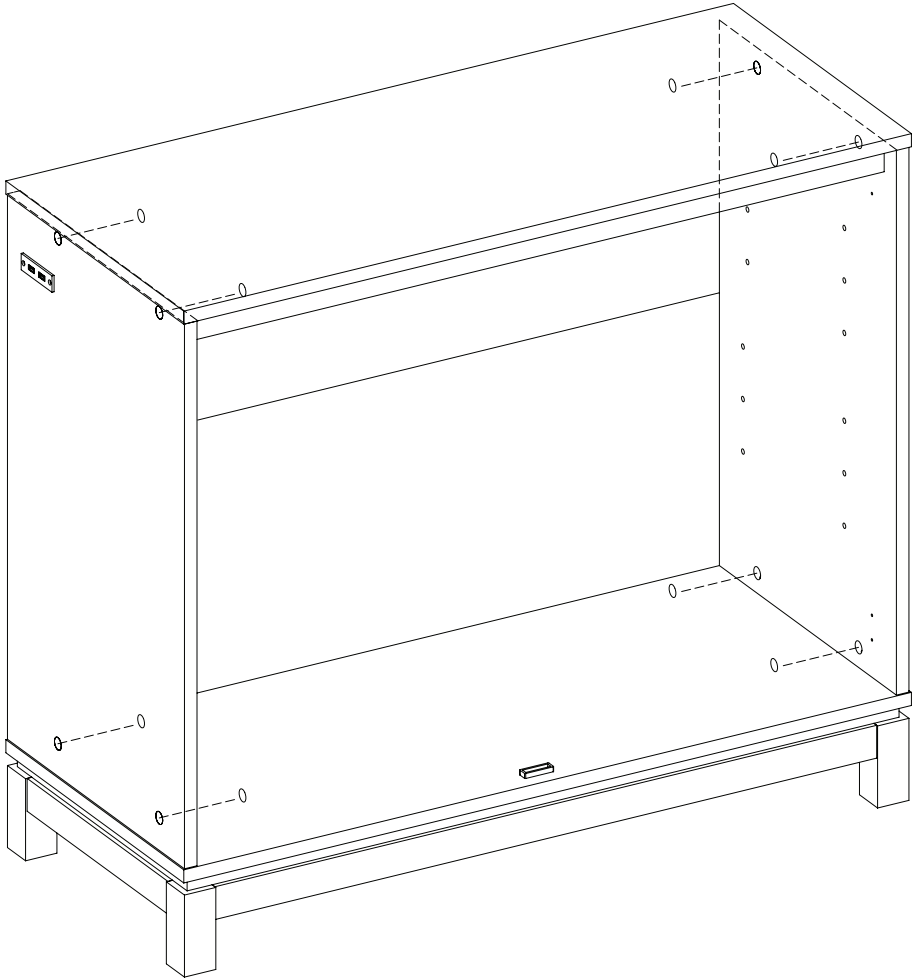

15

OO

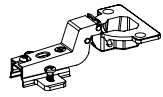

[x4]

PP

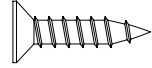

[x8]

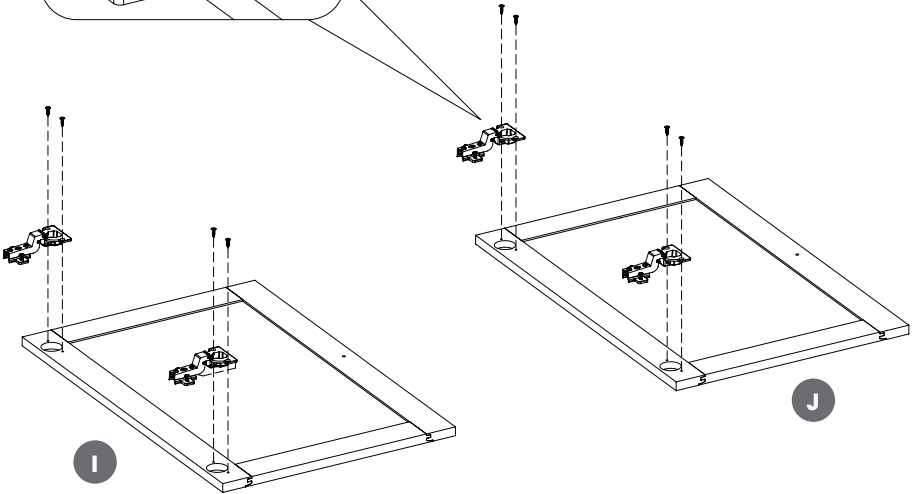
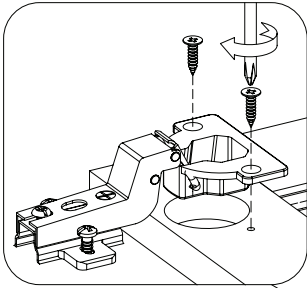

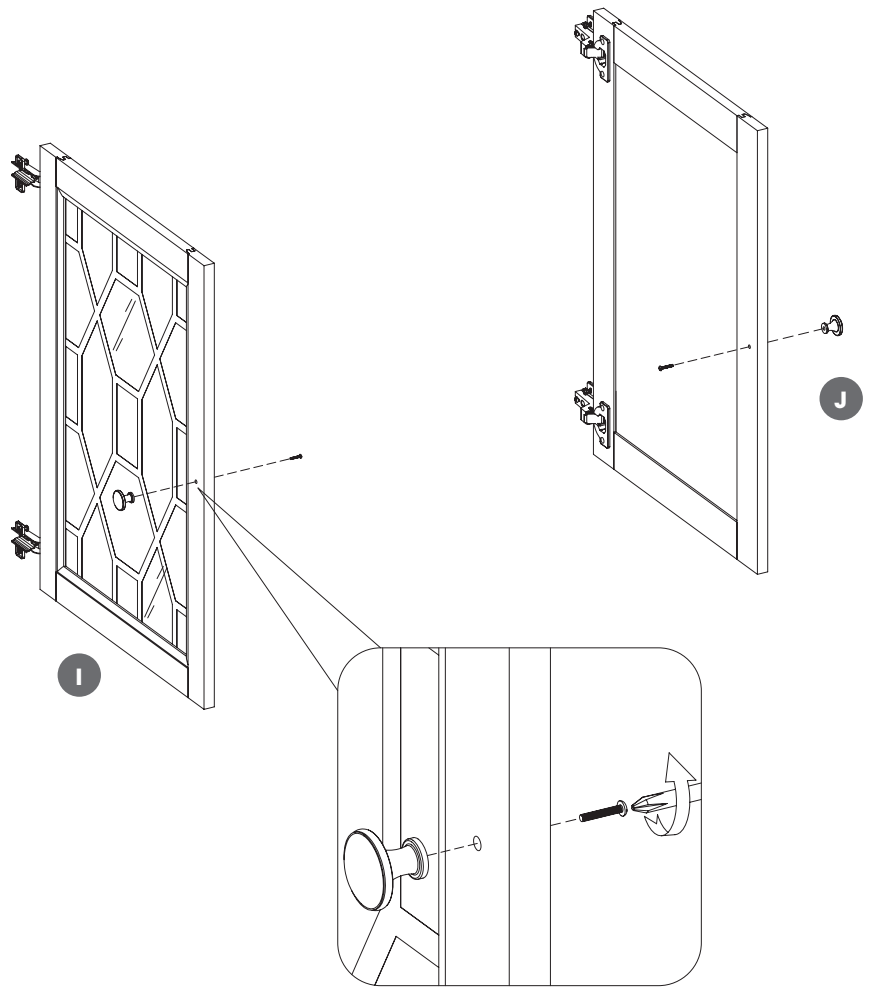

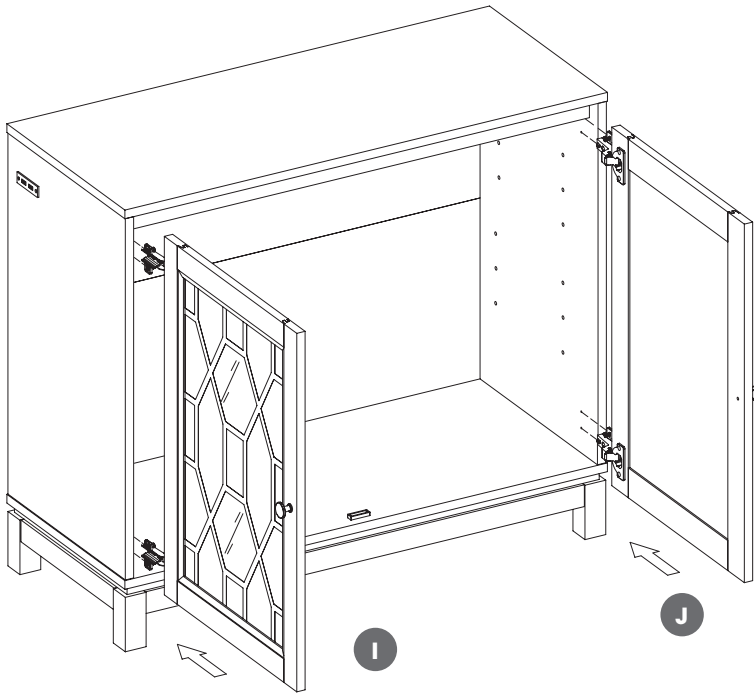
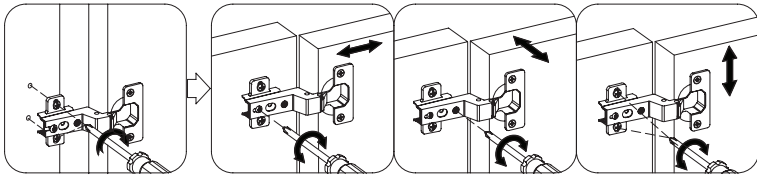

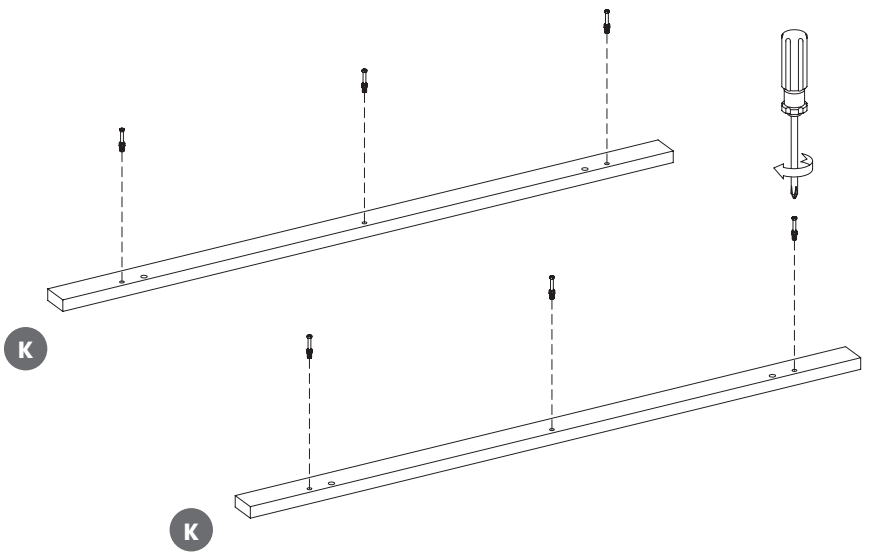

19



[x4]

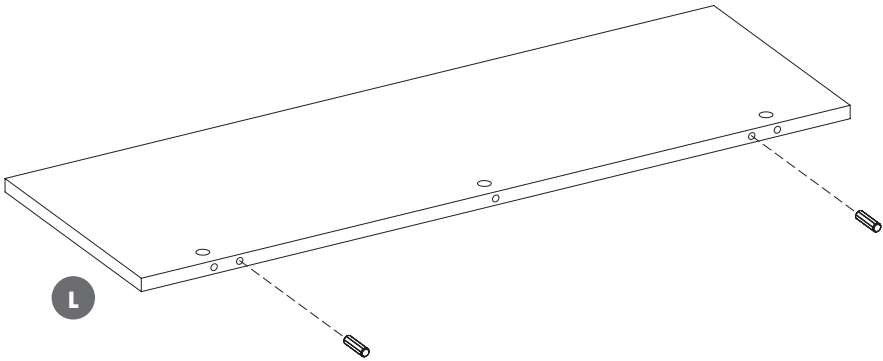
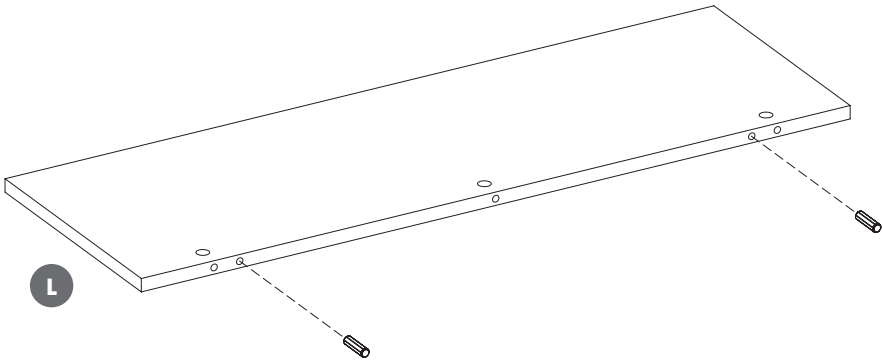

20

JJ



[x6]

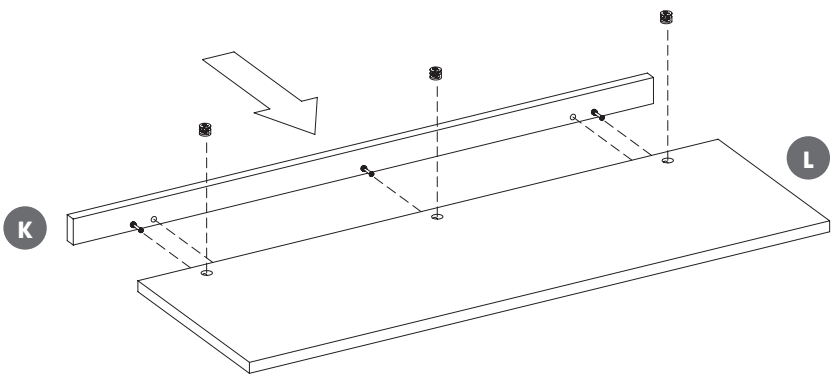
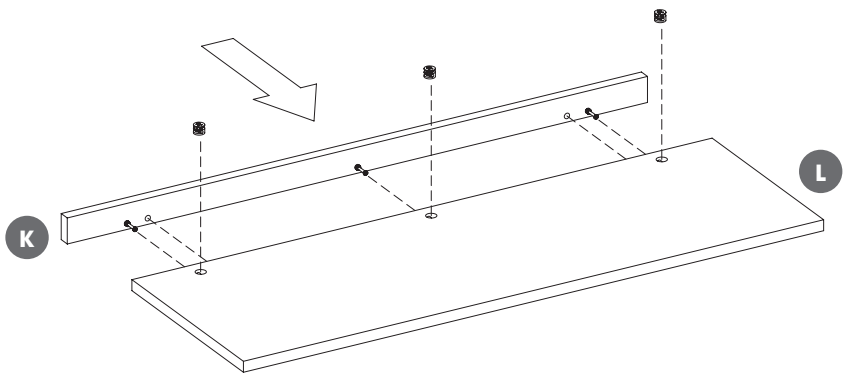
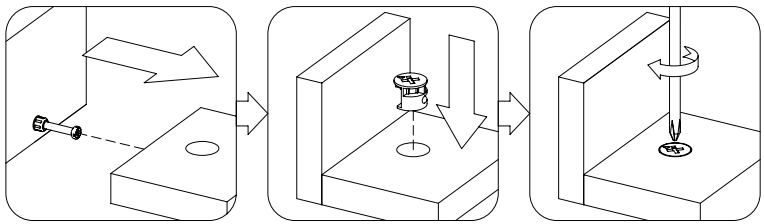

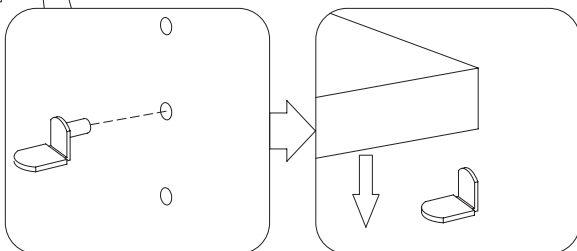
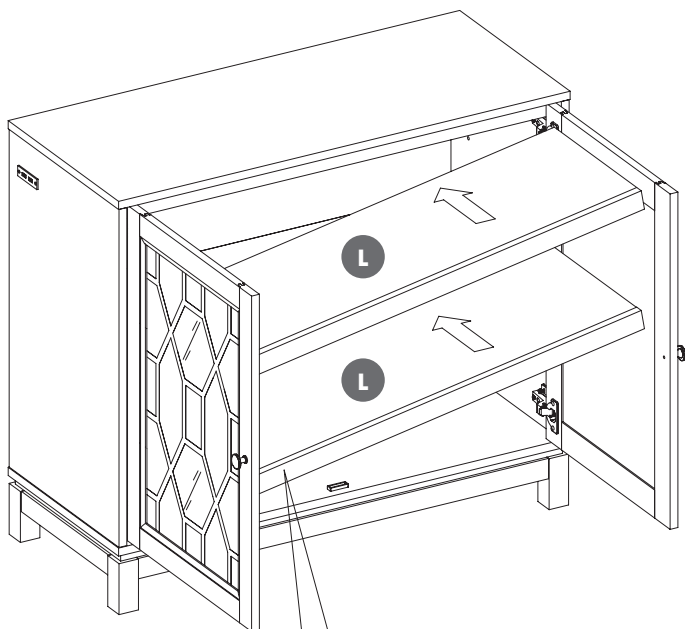
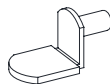

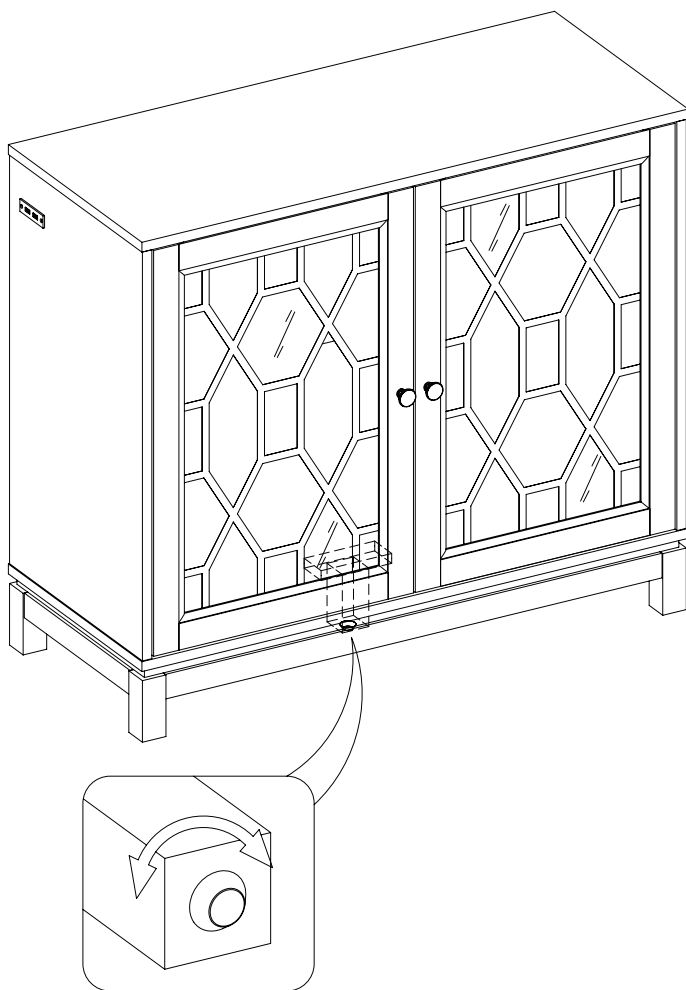

**Note:** It is very important that your unit is properly leveled. After moving your unit to its final location, you may need to adjust the floor levelers.

**Note:** Il est très important que votre unité soit au niveau correctement. Après avoir déplacé votre unité à son emplacement final, vous devrez peut-être ajuster les niveleurs de plancher.

**Nota:** Es muy importante que su unidad esté nivelada correctamente. Después de mover su unidad al lugar definitivo, debe ajustar la nivelación del piso.

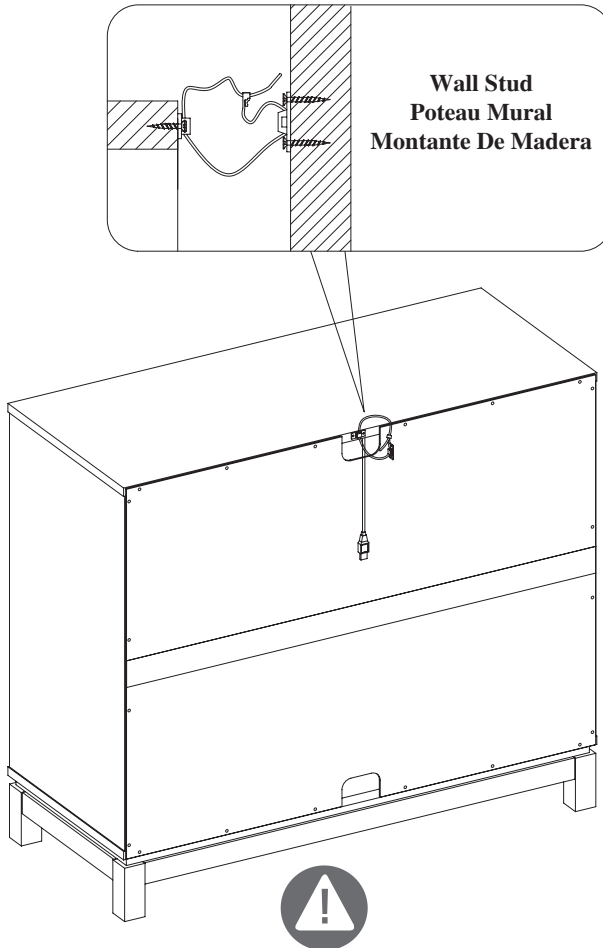
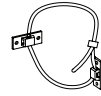

**Warning:** You must install the tip restraint hardware to help prevent any accidents or damage to the unit. We strongly recommend attaching the tip restraint hardware to a wall stud and your unit. For all other wall types, please visit your local hardware store to obtain the proper hardware.

**Avertissement:** Il est nécessaire d'installer les pièces d'arrimage anti basculement pour prévenir les accidents ou les dommages à l'unité.  
« Nous vous recommandons fortement de fixer le support avec retenue anti-basculement à un poteau mural et à votre unité. » En ce qui concerne tous les autres types de murs, veuillez visiter votre quincaillerie pour obtenir les articles appropriés.

**Advertencia:** Debe instalar el Herraje contra Caídas para evitar accidentes o que se dañe la unidad.  
«Recomendamos enfáticamente sujetar el extremo de la herramienta de retención a un perno de pared y su unidad». Respecto de todos los demás tipos de pared, vaya a su ferretería local para obtener las herramientas adecuadas.

**Care and Maintenance**

- Use a soft, clean cloth that will not scratch the surface when dusting.
- Use of furniture polish is not necessary. Should you choose to use polish, test first in an inconspicuous area.
- Using solvents of any kind on your furniture may damage the finish.
- Never use water to clean your furniture as it may cause damage to the finish.
- Always use coasters under beverage glasses and flowerpots.
- Liquid spills should be removed immediately, as it may damage the furniture. Use a soft, clean cloth and blot the spill gently. Avoid rubbing.
- Always use protective pads under hot dishes and plates. Heat can cause chemical changes that may create spotting within the furniture.

**Further advice about wood furniture care**

It is best to keep your furniture in a climate-controlled environment. Temperature and humidity changes can cause fading, warping, shrinking and splitting of wood. It is advised to keep furniture away from direct sunlight as sun may damage the finish. Proper care and cleaning at home will extend the life of your purchase.

We hope you enjoy your purchase for many years. Thank you for your purchase!

**Soin / Entretien**

- Lors de l'époussetage, utilisez un chiffon doux et propre qui n'égatigne pas la surface.
- Il n'est pas nécessaire d'utiliser du poli à meuble. Si vous décidez d'utiliser du poli à meuble, veuillez d'abord en faire l'essai dans un endroit moins en évidence.
- L'utilisation de solvant de quelque sorte sur votre ameublement peut endommager le fini.
- Ne jamais utiliser d'eau pour nettoyer votre ameublement car cela peut endommager le fini.
- Utilisez toujours des dessous de verre sous les verres/tasses des breuvages et sous les pots à fleur.
- Tout déversement de liquide doit être enlevé immédiatement car cela peut endommager l'ameublement. Utilisez un chiffon doux et propre et épongez délicatement le déversement. Évitez de frotter.
- Utilisez toujours des tampons protecteurs sous les plats et les assiettes chaudes. La chaleur peut causer des changements chimiques qui peuvent créer des taches sur l'ameublement.

**Conseils supplémentaires pour l'entretien de meubles en bois**

Il est préférable de garder vos meubles dans un environnement climatisé. Les changements de température et d'humidité peuvent décolorer, déformer, rétracter et fendiller le bois. Il est conseillé de garder les meubles à l'abri de la lumière directe du soleil car cela pourrait endommager le fini. L'entretien et le nettoyage appropriés à domicile prolongeront la vie de votre achat.

Nous espérons que vous apprécierez votre achat pendant de nombreuses années. Nous vous remercions pour votre achat!

**Cuidado / Mantenimiento**

- Use un paño suave y limpio que no raye la superficie cuando elimine el polvo.
- El uso de cera para muebles no es necesario. Si elige utilizar la cera, realice primero una prueba en un área discreta.
- Usar solventes de cualquier clase en sus muebles puede dañar el acabado.
- Nunca utilice agua para limpiar sus muebles, ya que puede causar daños en el acabado.
- Siempre utilice posavasos para colocar los vasos de bebidas y las macetas.
- Los derrames de líquidos se deben de secar inmediatamente, ya que pueden dañar el mueble. Use un paño suave y limpio y seque el derrame con cuidado. Evite frotar.
- Siempre utilice almohadillas protectoras debajo de los platos y vajillas calientes. El calor puede causar cambios químicos los cuales pueden crear manchas en los muebles.

**Consejos adicionales sobre el cuidado de los muebles de madera**

Lo mejor es mantener sus muebles en un ambiente con clima controlado. Los cambios de temperatura y humedad pueden hacer que la madera se decolore, se combe, se encoja y se parta. Se aconseja mantener los muebles alejados de la luz solar directa, ya que esta puede dañar el acabado. El cuidado y la limpieza adecuados en casa extenderán la vida útil de su compra.

Esperamos que disfrute de su compra durante muchos años. ¡Gracias por su compra!

# INSTALLED REPLACEMENT PARTS PIÈCES DE REMPLACEMENT INSTALLÉES PIEZAS DE REPUESTO INSTALADAS



[x9]



PH-THRZNC001



[x4]



PH-GLDBRW001



[x1]

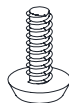

PH-LVRBLK001

## IMPORTANT INSTRUCTIONS

When using electrical appliances, basic precautions including the following should always be taken to reduce the risk of fire, electrical shock, and injury to persons:

### Warning:

Make sure the unit is turned off and unplugged before cleaning.

Do not connect the power supply to a household power outlet with wet hands, as it may cause fire, electric shock or injury to the person.

Do not operate this unit if the cord or plug is damaged, after a malfunction or if it has been dropped or damaged in any manner.

For indoor use only.

## INSTRUCTIONS IMPORTANTES

Al utilizar los aparatos eléctricos, debe tomar en cuenta las precauciones básicas que incluyen las siguientes para reducir el riesgo de incendio, descarga eléctrica y lesiones personales:

### Avertissement :

Assurer que l'unité est désactivée et débranchée avant de nettoyer la table.

Ne pas relier l'appareil à la source d'alimentation avec les mains mouillées, ce qui pourrait provoquer un incendie, un choc électrique ou une blessure.

Ne pas faire fonctionner avec un cordon ou une fiche endommagé, après défaillances de l'appareil ou s'il a été abandonné ou endommagé de quelque manière que ce soit.

Pour utilisation à l'intérieur seulement.

## INSTRUCCIONES IMPORTANTES

Lors de l'utilisation des appareils électriques, les précautions élémentaires, notamment celles suivantes doivent toujours être prises afin de réduire les risques de l'incendie, du choc électrique et des blessures corporelles:

### Advertencia:

Asegúrese de que la unidad esté apagada y desenchufada antes de limpiar la mesa.

No conecte la fuente de alimentación a una toma de corriente doméstica con las manos mojadas, ya que podría provocar un incendio, descargas eléctricas o lesiones a la persona.

No haga operar el aparato con un cable o enchufe dañado o después de un mal

funcionamiento, o si se ha caído o dañado de alguna manera.

Sólo para uso en interiores solamente.

## PRODUCT SPECIFICATIONS SPÉCIFICATIONS DU PRODUIT / ESPECIFICACIONES DEL PRODUCTO

USB Input Voltage/ Tension d'entrée USB/ Voltaje de entrada de USB

5V DC / Max 2.1A

USB Output Voltage / Tension de sortie USB / Voltaje de salida de USB

5V DC / Max 2.1A