

# OkiOki

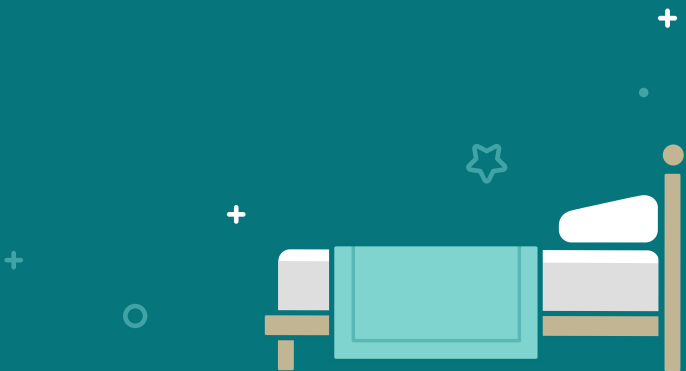

## OkiOki Mid-Century Nightstand Instructional Guide & Sleep Book



*We're providing you with the necessary directions to easily and seamlessly set up your new OkiOki Mid-Century Nightstand as well as some leisurely reading to reward your efforts.*

# Contents

---

- 3** Mid-Century Nightstand  
Instructional Guide
- 18** A Bedtime Story
- 22** Sleep Facts
- 24** Notes from My Bed

# OkiOki Mid-Century Nightstand

## Instructional Guide

### Assembly Instructions

2 persons recommended for assembly.

All instructional elements and diagrams provided in this manual are to serve as a guide and are not meant to replace a licensed professional. Any construction or use of the product must be in accordance with all local zoning and/or building codes. The consumer is liable for all risk and responsibility associated with the assembly and construction of this product. The person or persons responsible for setting up this product should follow all safety instructions carefully as to not put themselves or any other parties at risk.



Read instructions, cover to cover



Have two adults on hand for assembly



Do not assemble on flooring or carpet



Assemble on a clean, non-marring surface (packing foam)





Save all packaging until finished



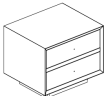

**\*\*CAUTION :** This Nightstand is NOT a TOY. Keep your child/children at bay in the process of assembly. For turning/flipping the Nightstand and to prevent damage to the Nightstand, 2 persons may be needed to execute this action.

# What's in the Box?



## Parts List

No.	Picture	Description	Qty
A		Cabinet	1
B		Leg	4
C		Knob (11x24x20mm)	2

## Nightstand Hardware

No.	Picture	Description	Qty
①		Bolt (M6 x 60mm)	9
②		Spring Washer (6.5/13x2mm)	9
③		Flat Washer (6.5/19x2mm)	9
④		Allen Key (K4)	2
⑨		Bolt (4x25mm)	2

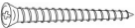
## Nightstand Restraint Device Hardware

⑤		Self Tapping Screw (M4 x 20mm)	3
⑥		Self Tapping Screw (M4 x 50mm)	3
⑦		L-shape Metal Bracket	4
⑧		Nightstand Restraint Strap	2

If any contents in the box are missing, please contact OkiOki support right away at 1-833-OKIOKI1.

# Assembly Preparation

Before beginning assembly:

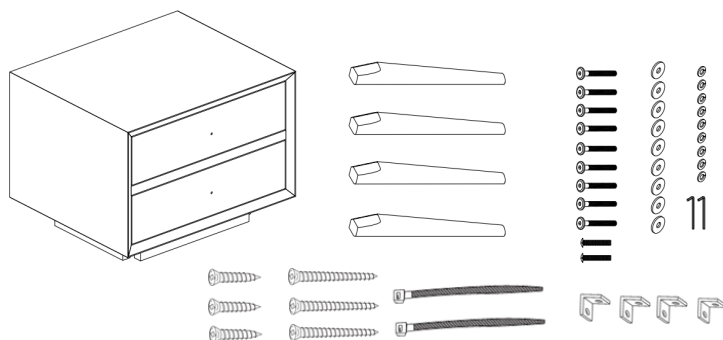

## OVERVIEW

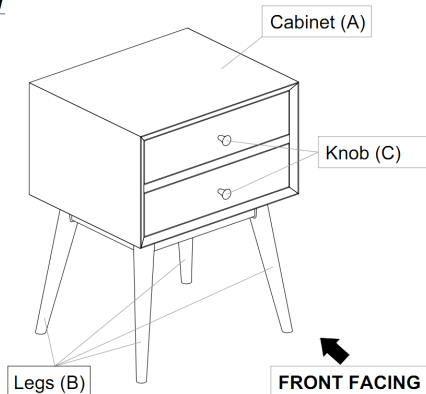

This Nightstand has multiple parts and may require up to 30 minutes to assemble. To give you an overview of the Nightstand parts, the above picture is to help you put the various parts into perspective. Please read through the instructions here below to familiarise the parts and steps before assembly.

# Now to the fun part!

Please follow the below steps carefully to ensure a proper assembly.

## Step 1

- Unpack and place all parts on a clean, non-marring surface.
- In the next step, you'll need to lay the cabinet down in order to assemble. To avoid risk for user, need take out the Drawer of the Cabinet.

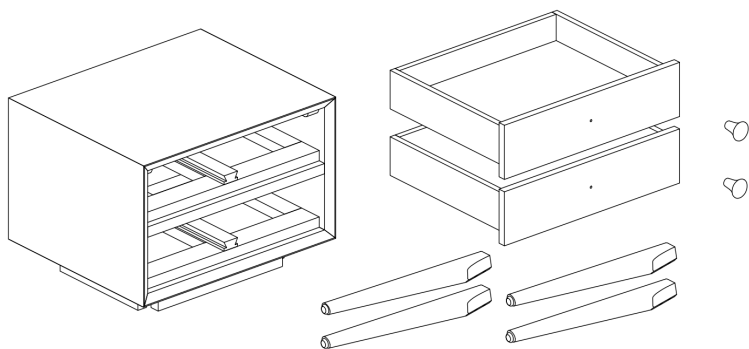

## Step 2

- Lay the Cabinet (A) down.
- Align and insert the Leg (B) to the mounting positions at the Cabinet's bottom corners.
- Insert the Bolt (1) through the mounting position and affix the Leg (B) using the Allen Key (4).
- The use of Spring Washer (2) & Flat Washer (3) are optional and are especially useful to help alleviate slight wobble.
- Upon assessment that there is a wobble, undo the relevant leg and thread in a Spring Washer (2) & Flat Washer (3)
- Make sure all parts are connected and securely locked into position.
- To ensure there is NO WOBBLES to the Legs (B), DO NOT overtighten the bolts.
- Each bolt is to be driven in sequentially and where necessary, the Nightstand may be turned to check for evenness.
- It may be necessary to execute this check twice to ensure that all Legs (B) are affixed to the Nightstand with no wobbles.

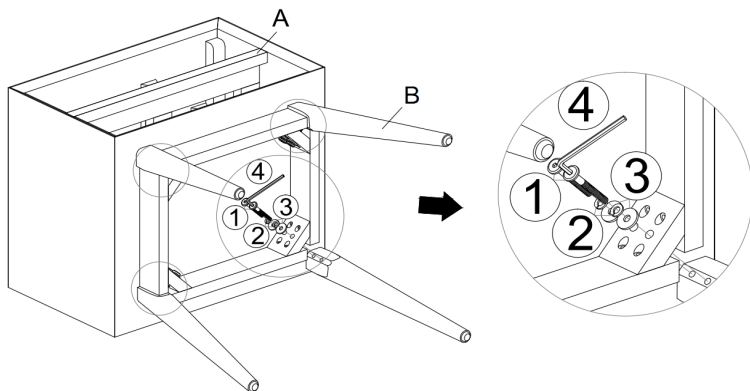

### Step 3

- Align the Bolts mounting position of the Knob (C) to the mounting positions at the Drawer.
- Insert the Bolt (9) through the mounting position and affix the Knob (C) by using Screw Driver (Not Provided), as shown in picture.

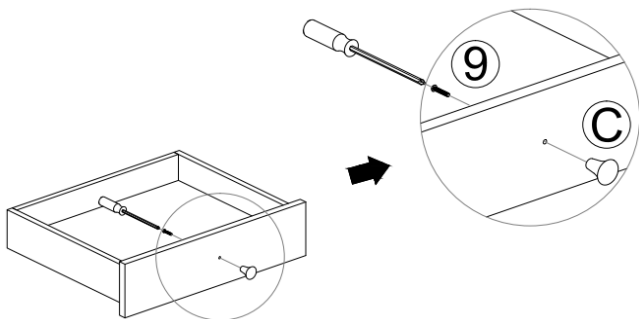

#### Step 4

- Put the Drawer into the Nightstand.
- Ensure that all bolts of the Nightstand and the Knobs of the Drawer are fully driven in and locked in.
- The Nightstand now is ready to be used.

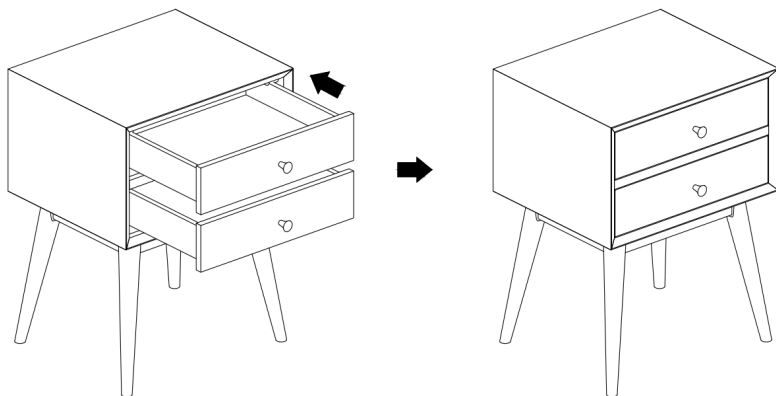

**\*\*Caution: This Nightstand can only be used on a flat, level surface.**

## Step 5

Take a step back and bask in the glory that is your new OkiOki Mid-Century Nightstand.

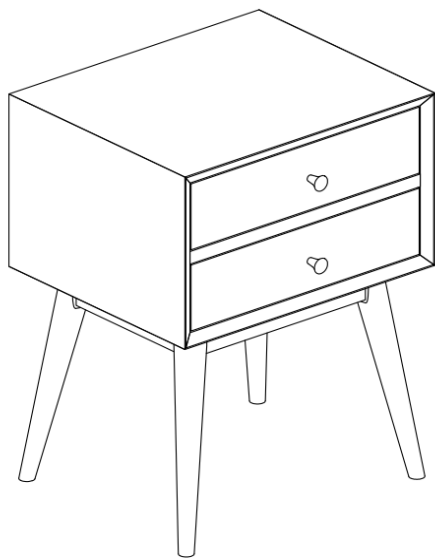

If additional help is needed in the assembly process, please reach out to our customer support team at 1-833-OKIOKI1.

# Nightstand Restraint Device Installation Instructions

Serious or fatal crushing injuries can occur from tipping furniture.

To help prevent tip-over: **ALWAYS** secure this furniture to the wall using a Nightstand Restraint Device.

See product instructions for more ways to help prevent furniture tip-overs.



**DO NOT CLIMB**

## Usage For Nightstand Restraint Device:

For the Nightstand against the wall, fix 2pcs Metal Brackets (7) on the wall and 2pcs Metal Brackets (7) on the product, use the Nightstand Restraint Strap (8) to connect the Metal Bracket (7) on the wall and the product. Find details as below:

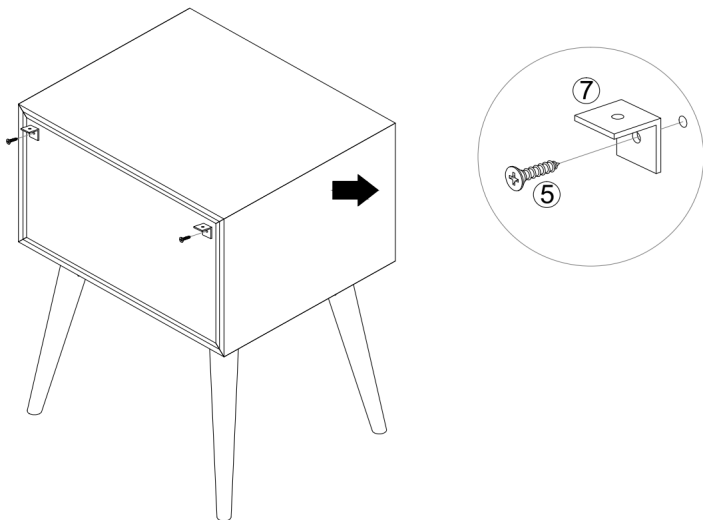

A: Firstly, turn back the Nightstand outwards as shown above. Then fix one Metal Bracket (7) on the back of the console by the 2.0cm Self-Tapping Screw (5). The distance of the screw mounting position to the two edges is about 1”.

Repeat this step to fix another Metal Bracket (7) on the product, as shown above.

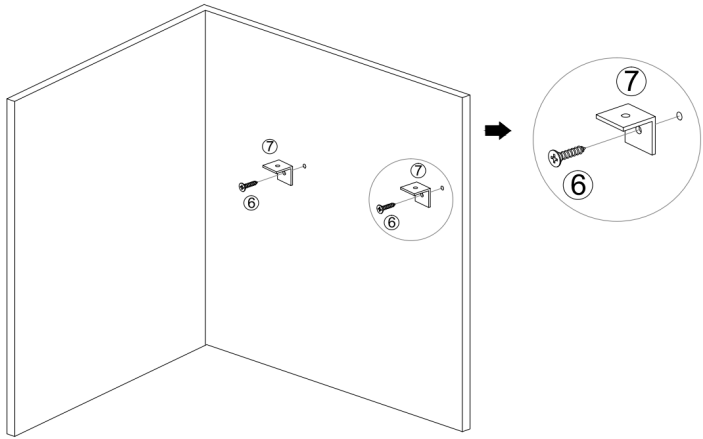

**B: Find the screw holes on the wall.**

First, mark the point at the same height on the wall as the L-shaped Metal Bracket (7) on the product. You can find these same points in 2 ways as below:

1. Move the Nightstand back to the wall - make sure these points on the wall and on the product are at the same height.
2. Measure the height of the Metal Bracket (7) and the wall by using a ruler to accurately keep them at the same height.

**\*\* (Caution: The space between the Nightstand Restraint Strap (8) and the Metal Brackets (7) on the product and the wall should be within 3.5").**

1. Then fix one L-shaped Metal Bracket (7) on the mark on the wall by the 5cm Self-Tapping Screws (6).
2. Repeat this step to fix another Metal Bracket (7) on the wall as shown above.

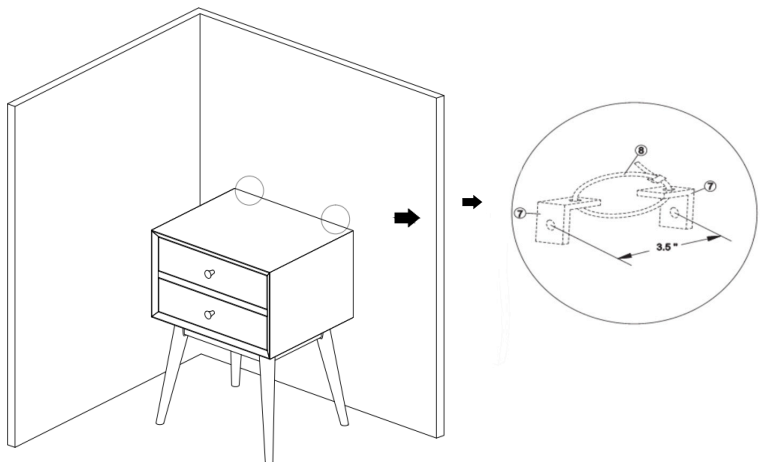

C: Move the Nightstand against the wall. Then pull the Nightstand Restraint Strap (8) through the 2 Metal Brackets (7), one by one, locking the Nightstand Restraint Strap (8) tight, as shown above.

The Nightstand Restraint Device is now installed and is ready for use.

# Care & Maintenance for your new Mid-Century Nightstand



Do not put hot items directly on furniture surface.



Do not clean furniture with harsh cleansers or polish.



Do not place furniture near heating or cooling vents.



Not for commercial use. For residential use only.



Stains may be removed with mild soap solution and damp cloth.



Children should not climb or jump on the furniture.



Dust and pick-up spills using a clean, non-colored, lint-free cloth.

# Congrats are in order.

**Congratulations on completing your new  
OkiOki Mid-Century Nightstand!**

While we know this was no small feat, we also bet it was pretty fun and rewarding. If you're not feeling completely rewarded and maybe still a little defeated, let us try to help you out by providing some light reading material to inspire, educate, or just make you laugh.

Enjoy & rest easy.



# The OkiOki Sleep Guide

# A bedtime story





nce upon a time, there was a young boy with endless energy, who had trouble falling asleep at night.

He spent the first few years of his life in the Midwest, but his parents soon uprooted the family to New Zealand to care for aging grandparents. Without many friends, he found himself often running alone in the wilderness, amongst the tranquil yet vibrant landscape. In this new and unfamiliar land, he soon discovered that New Zealand actually had more sheep than people. He would often walk miles without seeing anyone, but couldn't walk 100 feet without seeing sheep. He would run around the sheep, roll under them, jump over them and spend hours frolicking amongst the friendly creatures. It became his favorite pastime. The sheep seemed to enjoy his companionship just as much, as their human counterpart could pivot quickly and run fast, proving a worthy playmate in the rolling hills. One sheep, in particular, would always playfully chase the boy halfway home, eventually turning around to rejoin the herd. He called him Swifty.

When the young boy returned home after a day of play, he would tell his parents and grandparents about his adventures with great enthusiasm. The boy jumped off the walls with exuberance, acting out his favorite moments of the escapades. The zeal with which he re-lived these moments made it seem like he loved telling about the adventures as much as he loved living them.

As the rest of the household fell asleep, he would lay in bed, staring at the ceiling, his mind racing about what fun he'd have tomorrow. After weeks of restless nights, he realized that if he counted all of his sheep friends, who he identified by the hue and thickness of their respective fleeces, he could fall asleep more easily. This practice became his comforting method of dozing off each evening, counting the sheep, always starting with Swifty.

He would play all day and count sheep to sleep at night. One day, as the boy got ready to head home, Swifty was nowhere to be seen. The boy sprinted from the herd, and no sheep followed. This happened several days in a row, and Swifty's absence started to concern the boy.

He started to have trouble falling asleep. Weeks went by, then months. Maybe he wandered to another herd. Perhaps he fell off a cliff. Maybe Swifty found a better life elsewhere. Swifty was gone.

The boy would lay in bed at night, staring restlessly at the ceiling. Noticing that he was distraught, the boy's mother sat on the edge of the bed one night and asked why he could no longer fall asleep. He missed Swifty. Counting sheep no longer comforted him and didn't calm him. His mother empathetically rubbed her hand through his hair, petting him repeatedly with maternal care. "OkiOki, okioki." She repeated this as he dozed off to sleep. OkiOki, the Maori word for rest, tranquility, and relaxation soothed the young boy. This ritual continued for years; the OkiOki tradition continued beyond the young boy, with his children, and his children's children.

**For generations now, well-rested people have depended on the lore of OkiOki.**

# Sleep Facts

A list of fun and surprising facts about sleep.



- Only 21% of Americans get the recommended 7 to 8 hours of sleep each night.
- Humans are the only mammals that delay sleep.
- The average person falls asleep in 7 minutes.
- 60% of American adults experience sleep problems at some time.
- Insomnia is the most common sleep disorder.
- Women sleep more than men.
- One sleepless night affects your brain the same way as being drunk.
- When you're in REM sleep, your brain is almost as active as when you are awake.
- Got a problem? Sleep on it! REM sleep is proven to help creative problem-solving.

*source: <https://www.thegoodbody.com/sleep-facts/>*

# Notes from my bed

A few fun, quirky  
apology notes that  
you can cut out, sign,  
date, and give to  
whomever you please.

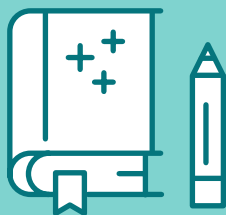



**Sorry I was late!  
I couldn't leave my bed.**

**#SleepOkiOki**

SIGNATURE \_\_\_\_\_ DATE \_\_\_\_\_

*okioki.com*          *@SleepOkiOki*

**Woke up late. You can  
blame my mattress.**

**#SleepOkiOki**

SIGNATURE \_\_\_\_\_ DATE \_\_\_\_\_

*okioki.com*          *@SleepOkiOki*

**Apologies for the tardiness,  
my bed was just too comfy.**

**#SleepOkiOki**

SIGNATURE \_\_\_\_\_ DATE \_\_\_\_\_

*okioki.com*          *@SleepOkiOki*











# Mattress Recycling Program

New laws in California, Connecticut, and Rhode Island now require retailers to collect a small fee at check-out for each mattress sold. The fees are then transferred to the state to fund their recycling efforts. The collection of fees is mandated by these new laws. The Mattress Recycling Council (MRC), a non-profit organization established by the mattress industry, created and manages the program. The MRC utilizes a network of organizations to effectively pick up, transport and recycle old mattresses within the new government regulations. To learn more about the initiative, visit [mattressrecyclingcouncil.org](http://mattressrecyclingcouncil.org). In an effort to promote recycling programs, OkiOki covers the entire recycling fee.



# OkiOki

[okioki.com](http://okioki.com)



[@SleepOkiOki](https://www.instagram.com/SleepOkiOki)