

# ASSEMBLY INSTRUCTION

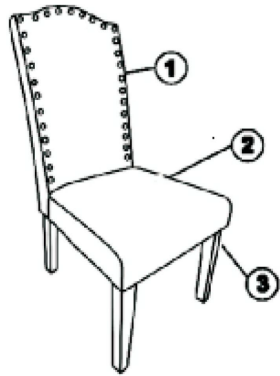

①

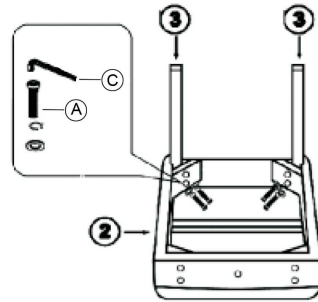

Insert the screws in the holes, tighten the screws, but not too tight, 90% is OK.

②

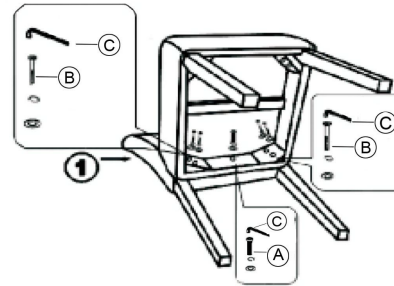

Insert the screws in the holes, tighten the screws, but not too tight, 90% is OK.

③



Use body weight to adjust balance of chair, then tighten all the screws all the way.

④

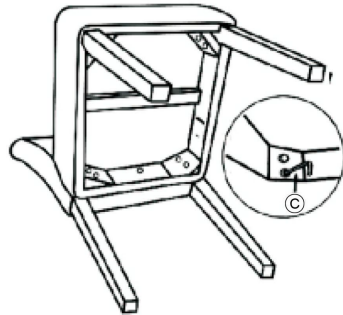

Tight all the screws to 100%

⑤

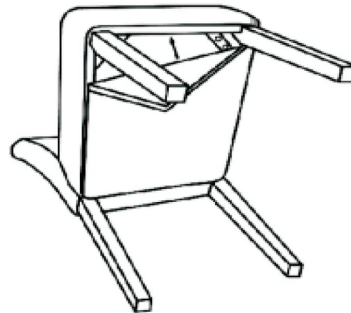

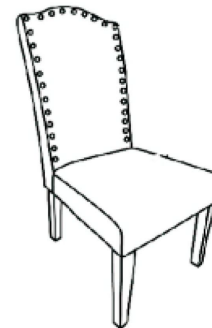

Stick the black part on the seat

⑥



A few days after initial assembly, the product may acclimate to its new environment. Please ensure all screws are still securely tightened.

HARDWARE LIST	CODE	PARTS	QTY.
	1	BACK	1
	2	SEAT	1
	3	FRONT LEG	2

HARDWARE LIST	CODE	PARTS	QTY.
	A	M8x60MM 	5
	B	M8x80MM 	4
	C	ALLEN KEY 	1

\* Tool kit is in the seat \*