

ASSEMBLY INSTRUCTIONS



373 - 918

TOOLS REQUIRED:

Allen Key (supplied, Part # F)

BEFORE YOU START:

1. Check the hardware against the hardware list to make sure all items are present.
2. Assemble your furniture on a soft, flat surface to avoid scratching the finish.
3. **CAUTION:** Do not over tighten screws, nuts or bolts during assembly.
4. Your furniture may require occasional tightening.

INSTRUCTIONS:

1. Turn Table Top on to a clean, soft surface. Attach Metal "L" (G) on the Legs by using Bolt (D) with Allen Key (F). (See Figure 1).
2. Attach two legs on the table by using Flat washer (C), Lock Washer (B), Bolt (A) with Allen Key (F). (See Figure 2).
3. Attach two legs and bottom shelf on the table of step 2. (See Figure 3).
4. Then using Flat washer (C), Lock Washer (B), Bolt (A) with Allen Key (F) to connect leg of step 4 on the table. (See Figure 4).
5. Using Flat washer (E), Lock Washer (B), Bolt (D) with Allen Key (F) to connect bottom shelf of step 4 on the table. (See Figure 5). Tighten all bolts with Allen Key (F).
6. Place the table upright, adjust the level up and down to level the table. Your table is now ready for use.

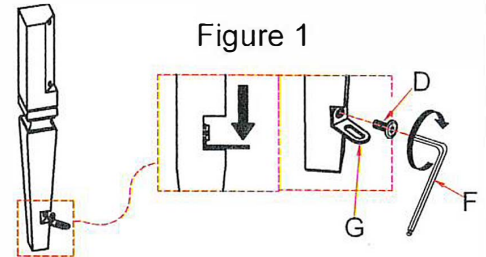

Figure 1

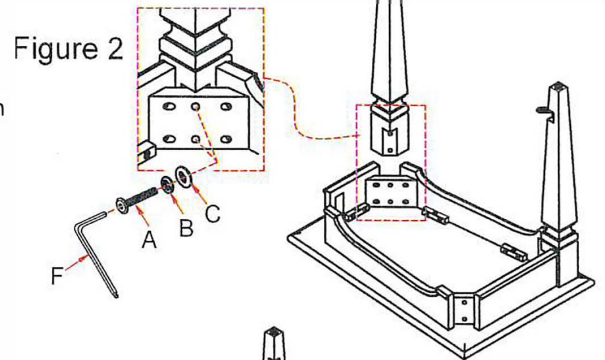

Figure 2

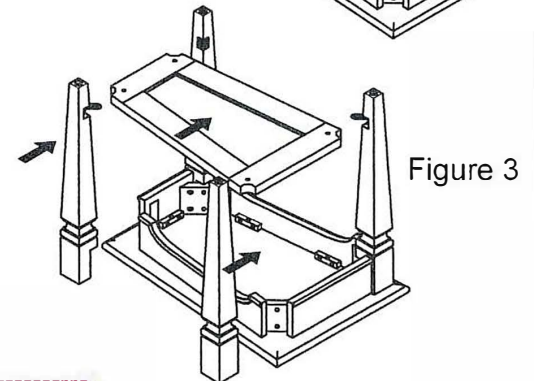

Figure 3

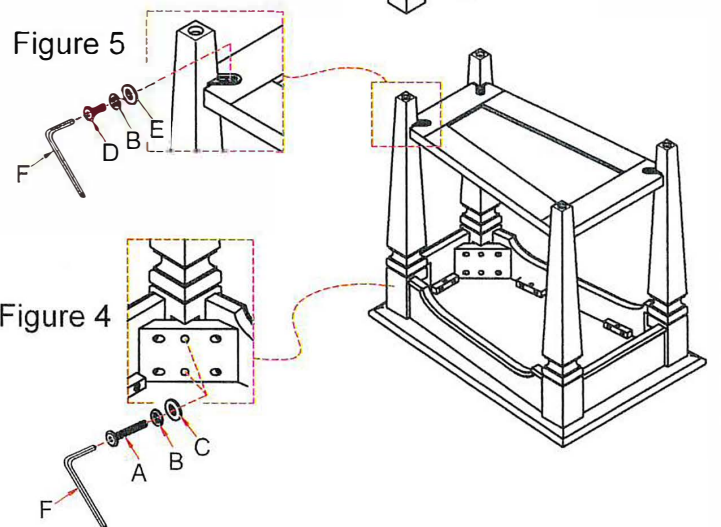









Figure 5

Figure 4

No.	Hardware List	Q'ty
A	 Bolt Ø1/4" x 2"	8
B	 Lock Washer Ø1/4"	12
C	 Flat Washer Ø1/4"*Ø3/4	8
D	 Bolt Ø1/4 x 5/8"	8
E	 Flat Washer Ø1/4"*Ø5/8	4
F	 Allen Key (100*50*4mm)	1
G	 Metal "L" 41 x 21 x 18mm	4