

Assembly Instructions

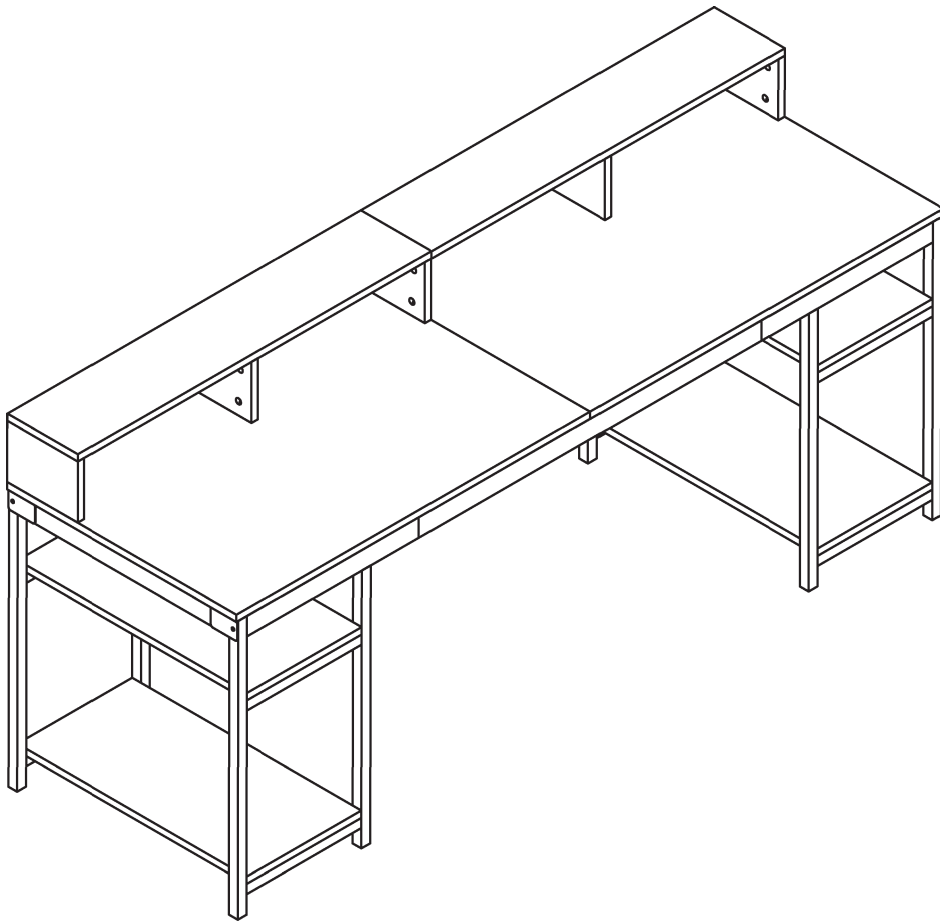

Warm Tips

1. Carefully read these instructions and keep them for future reference.
2. Check the parts list and confirm everything's there before starting assembly.
3. When assembling, put all parts on a soft, smooth surface like a carpet to avoid scratches.
4. Don't fully tighten screws until all parts are confirmed in place to avoid misalignment.

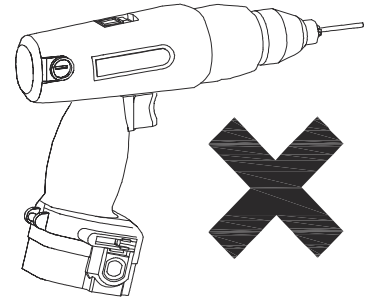
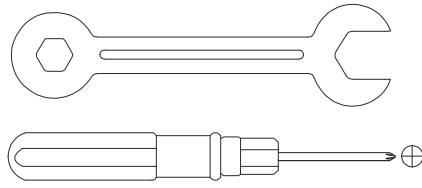
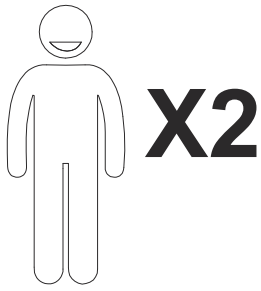

We recommend using hand tools for assembly.

If an electric screwdriver is used, reduce power and torque to avoid damage to the product.

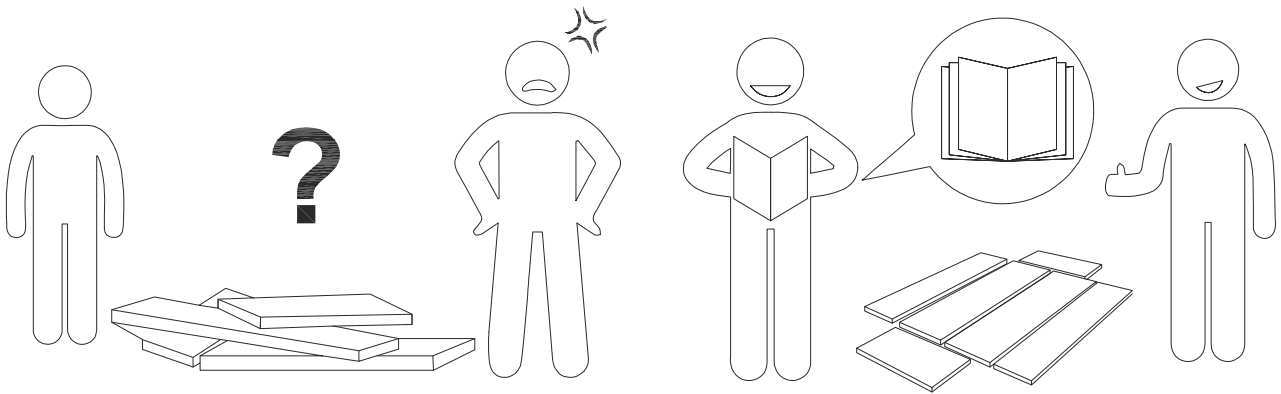

AVOID SCRATCHES

In order to avoid scratching, this furniture should be assembled on a soft surface, such as a rug.

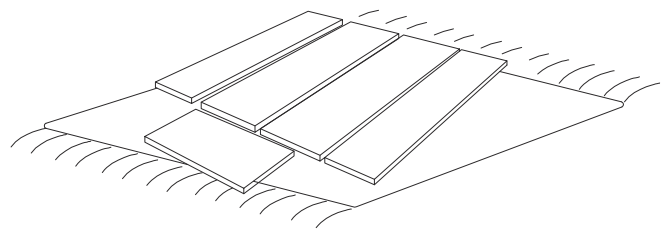
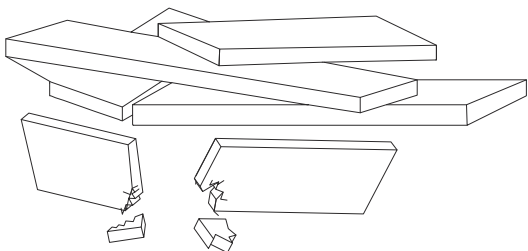

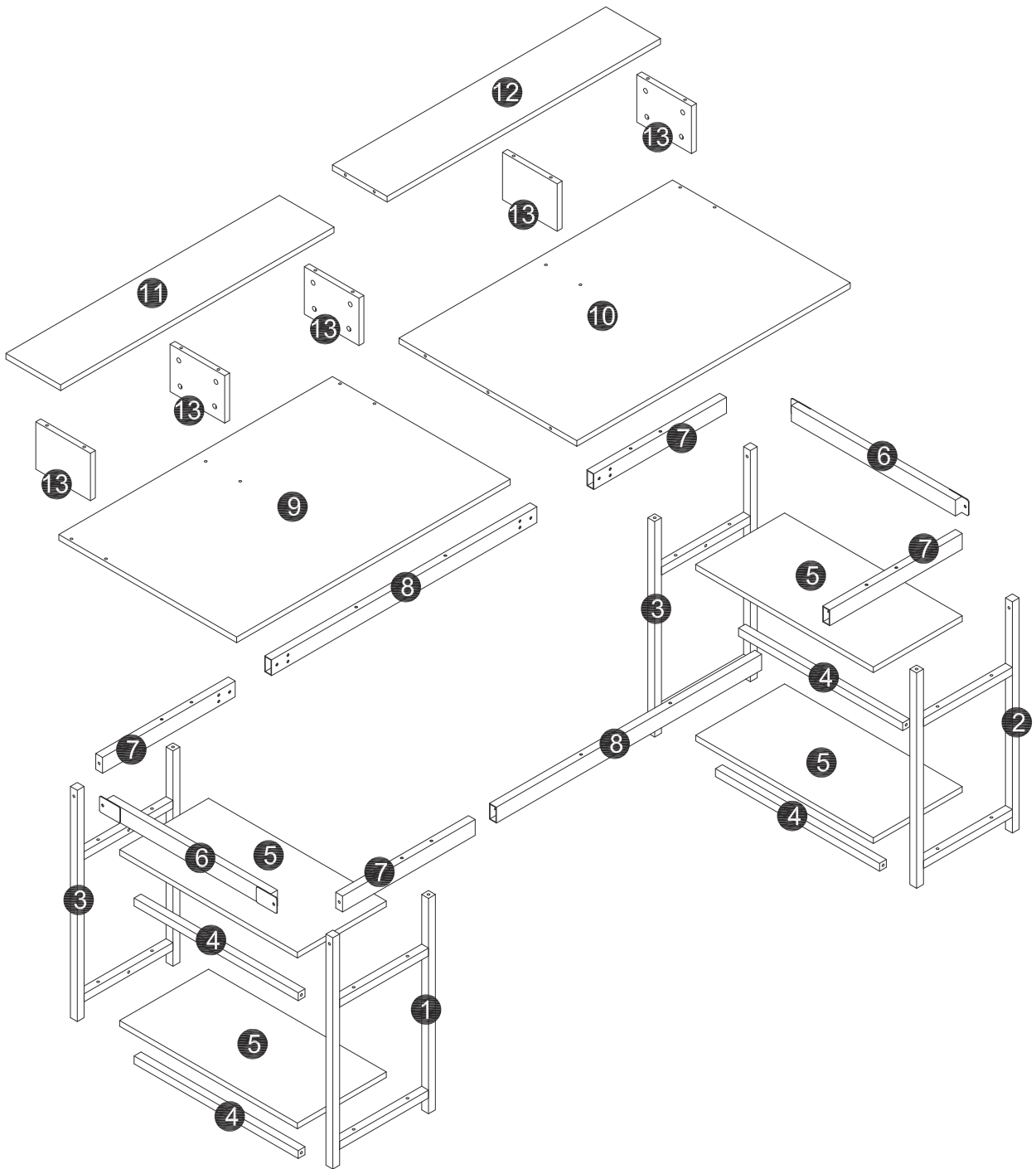







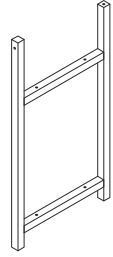
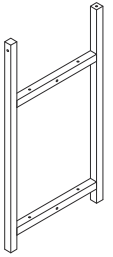
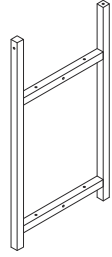
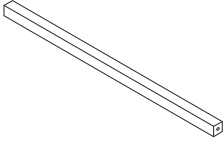
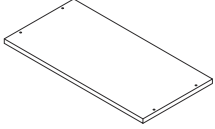
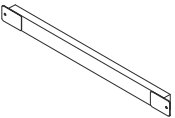
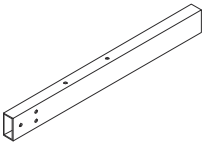
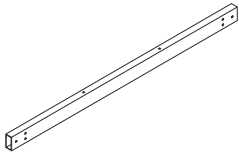
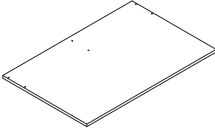
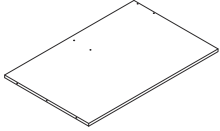
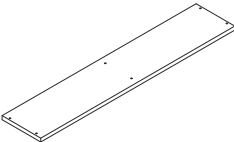
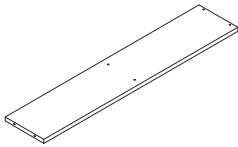
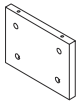



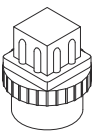

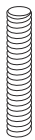
⚠ Caution

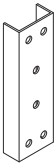
Make sure all parts are included. Most board parts are labeled or stamped on the raw edge. Contact us for a free replacement if you encounter any damaged or missing parts.

Parts List

 ① 1pc	 ② 1pc	 ③ 2pcs	 ④ 4pcs	 ⑤ 4pcs
 ⑥ 2pcs	 ⑦ 4pcs	 ⑧ 2pcs	 ⑨ 1pc	 ⑩ 1pc
 ⑪ 1pc	 ⑫ 1pc	 ⑬ 5pcs		

Hardware List

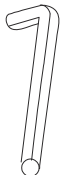
 A 8 pcs	 B 4 pcs	 C 4 pcs	 D 16 pcs	 E 4 pcs	 F 24 pcs	 G 4 pcs
 H 4 pcs	 J 20 pcs	 K 8 pcs	 L 20 pcs	 M 5 pcs	 N 2 pcs	

Installation of Cams and Pins

Read each step carefully before starting. Each step of instruction should be performed in the correct order. If these steps are not followed in sequence, assembly difficulties may occur.

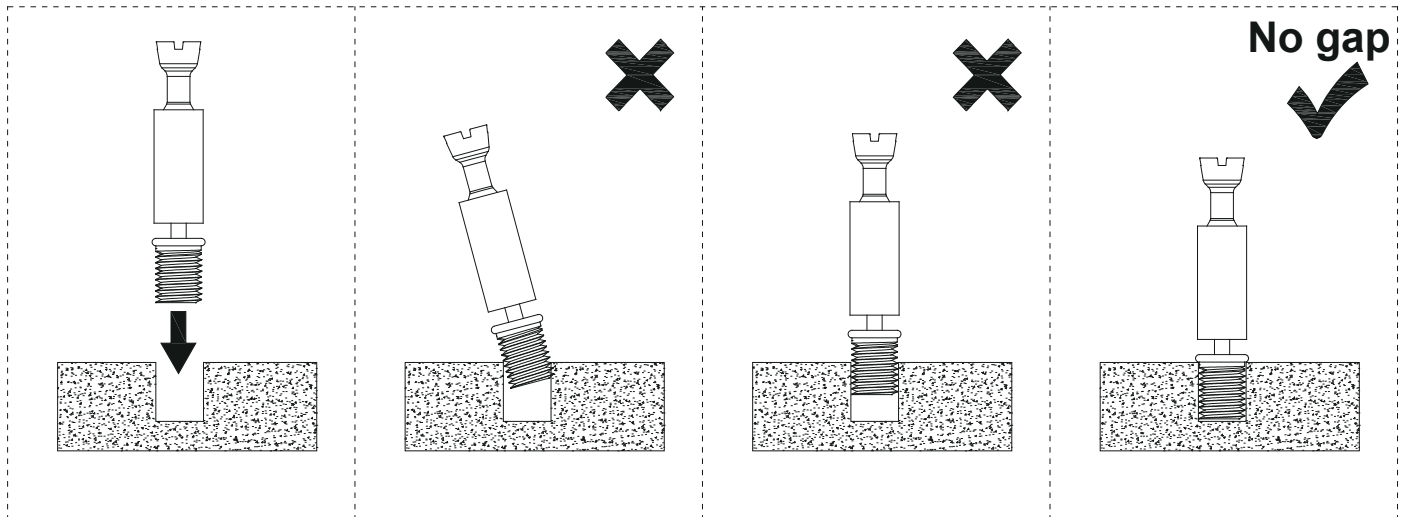

Screw the pin into the hole. Set the cams correctly by aligning the head of the cams with the lock pins. Lock the cam by turning the cam head with a screwdriver until it is tightened. Please do not use an electric screwdriver to assemble the unit.

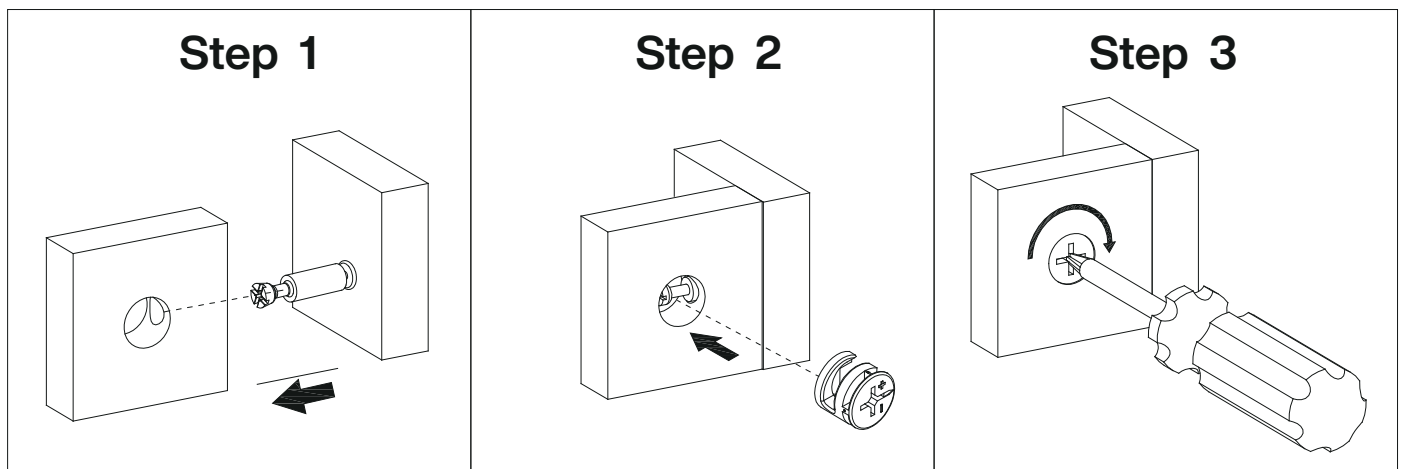

1

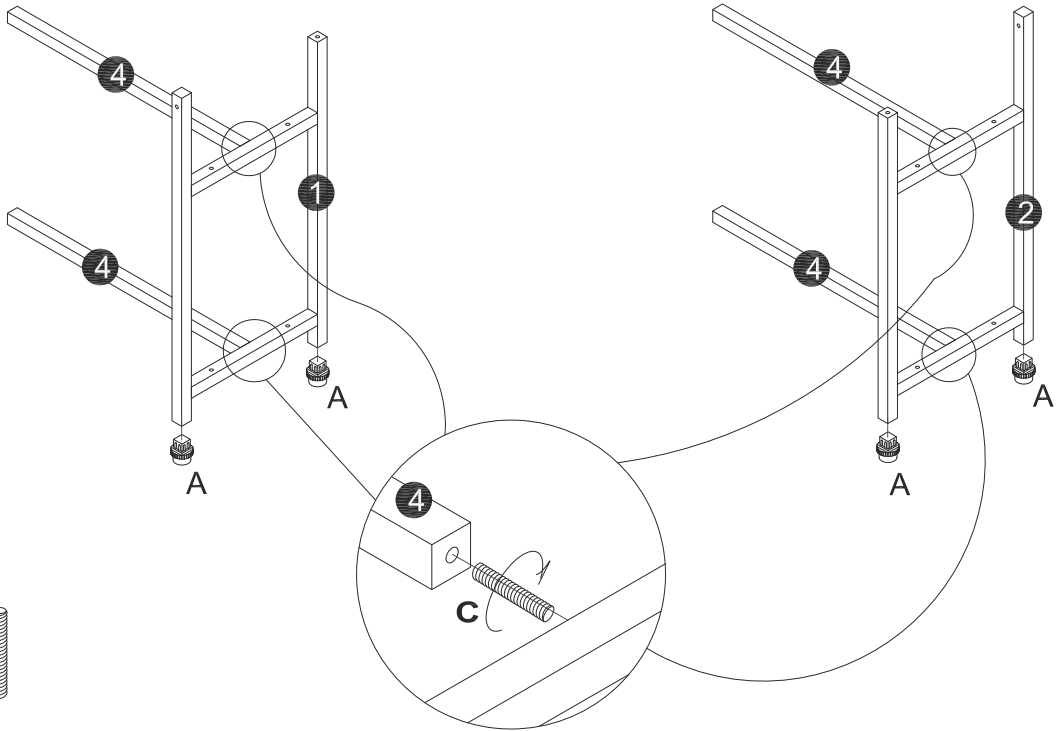

A
4 pcs



C
4 pcs

2

Please note that the holes are on the same side.

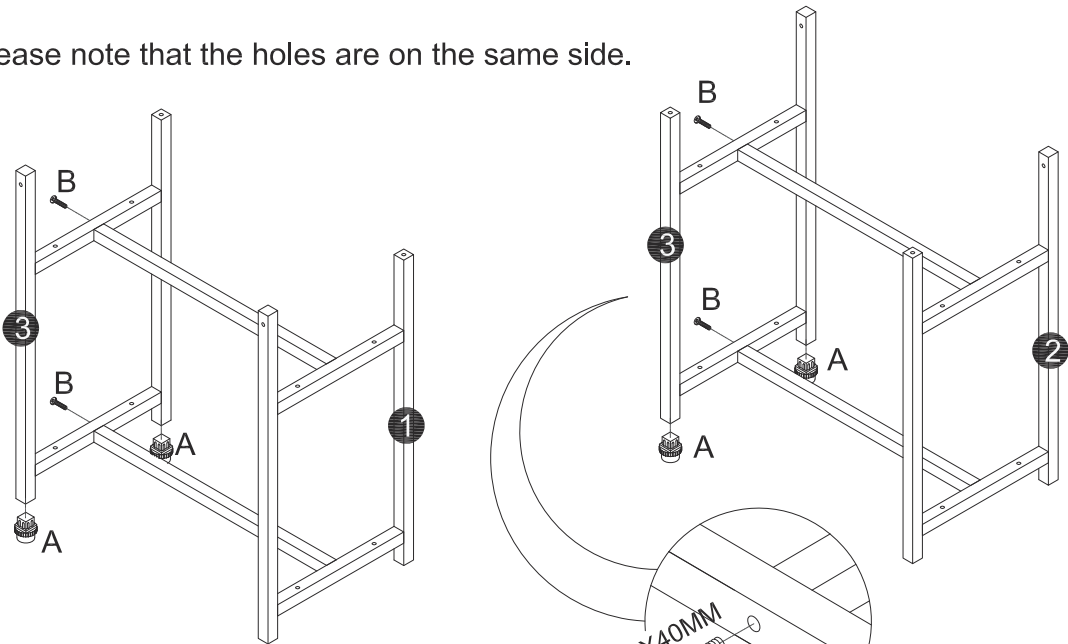

A
4 pcs



B
4 pcs

3

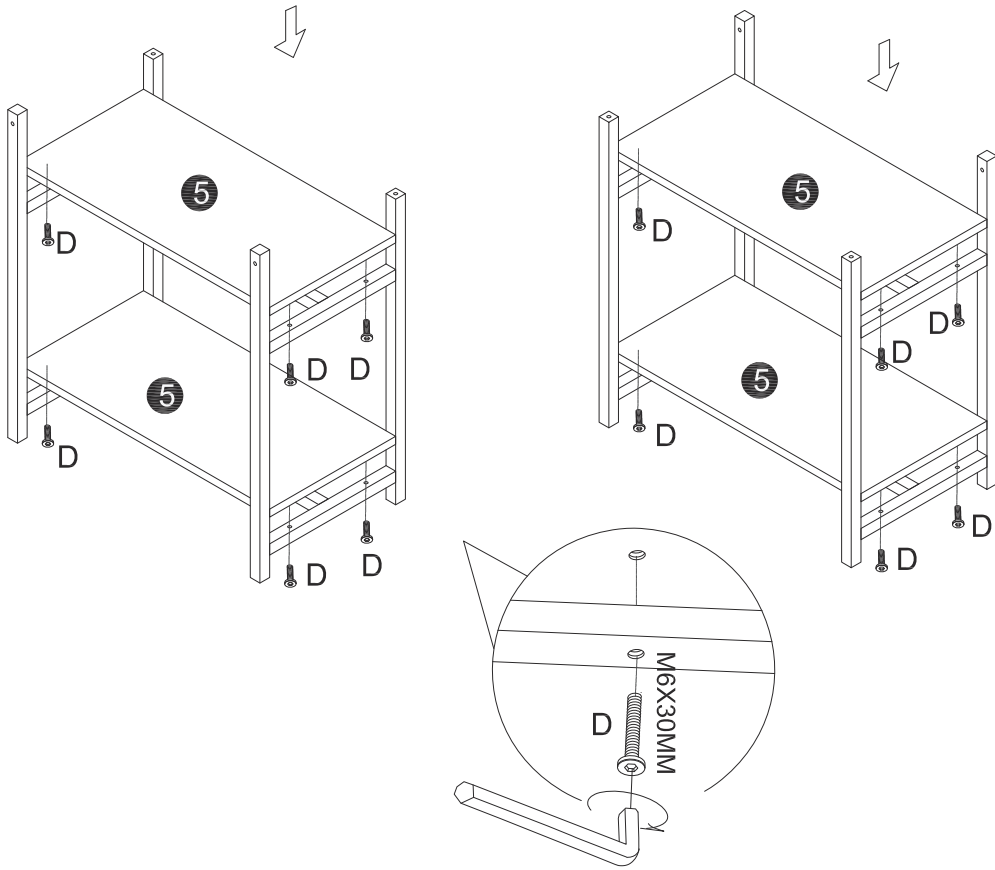

M6X30MM
D
16 pcs

4

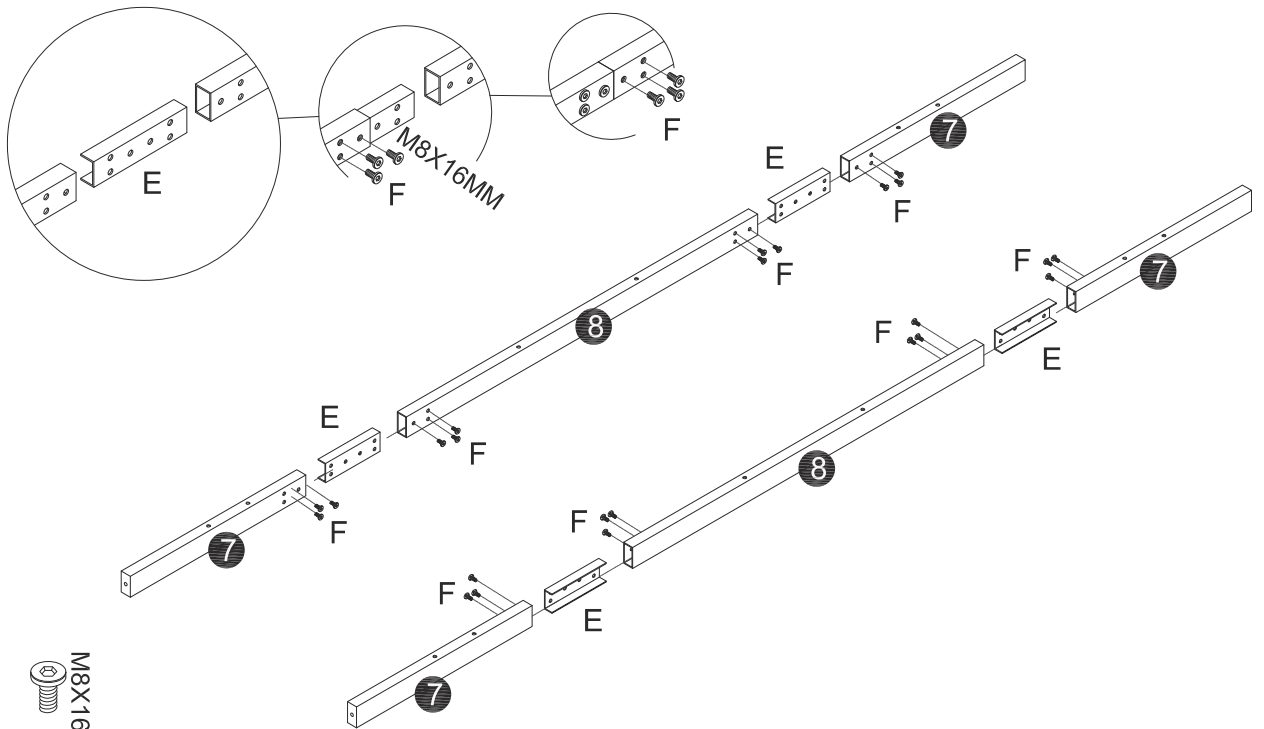

E
4 pcs

M8X16MM
F
24 pcs

5

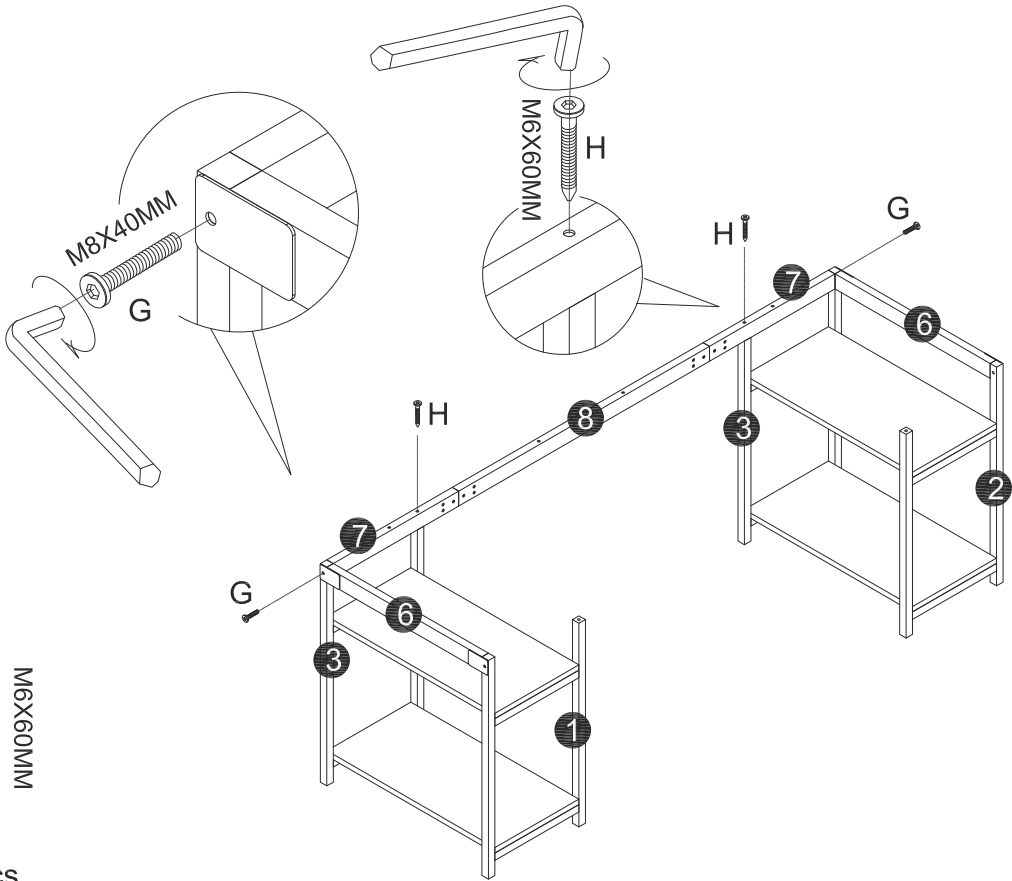

- M8X40MM
G
2 pcs
- M6X60MM
H
2 pcs

6

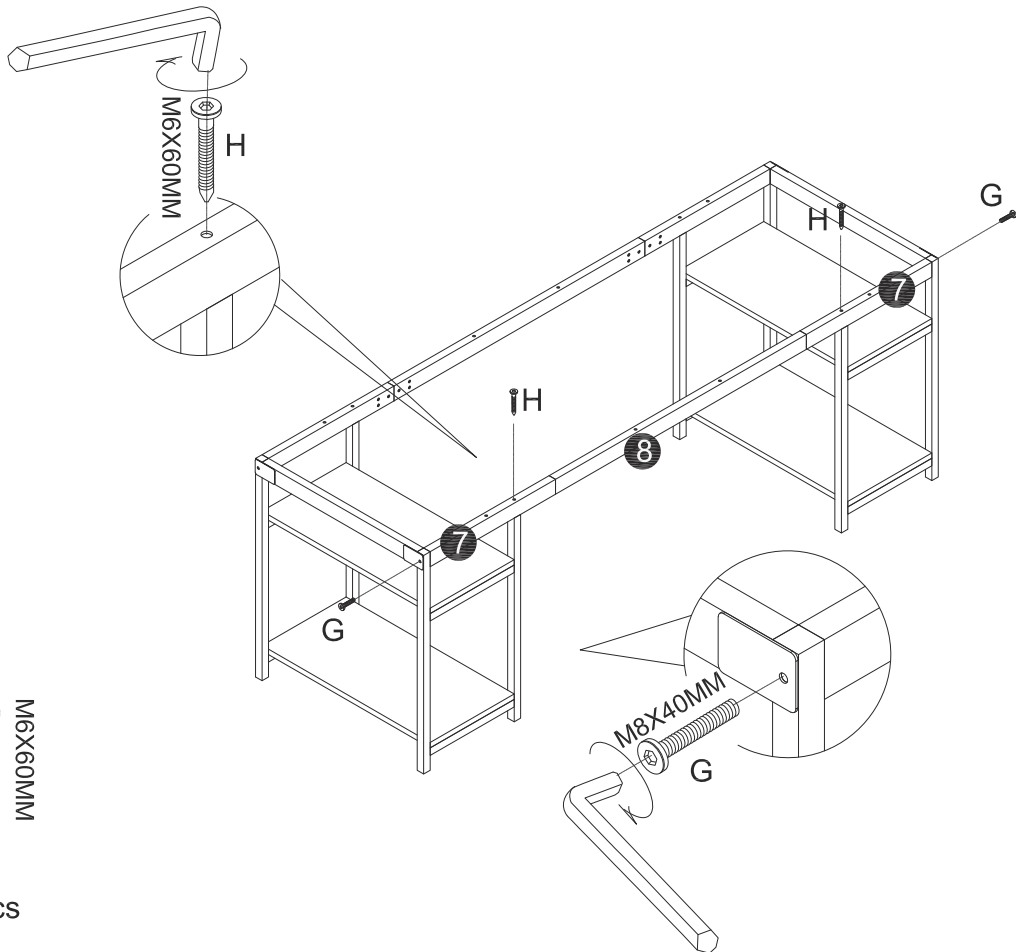

- M8X40MM
G
2 pcs
- M6X60MM
H
2 pcs

7

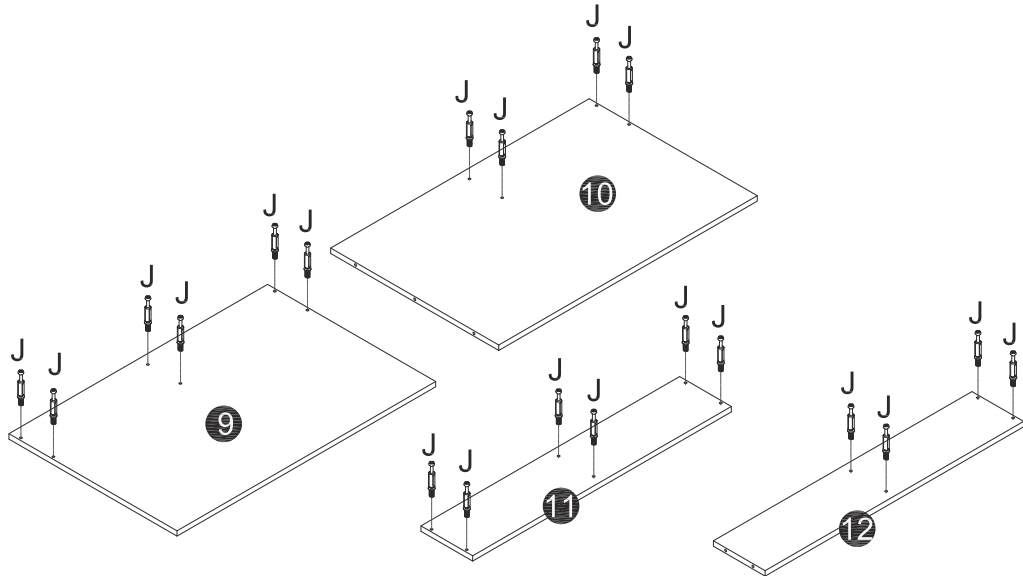
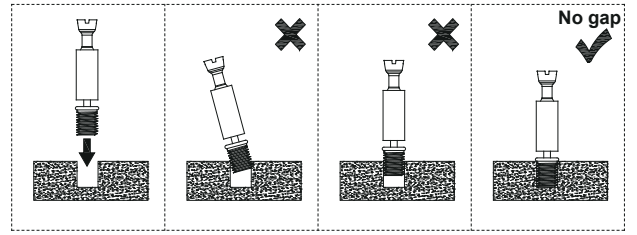

M6X35MM
J
20 pcs

8

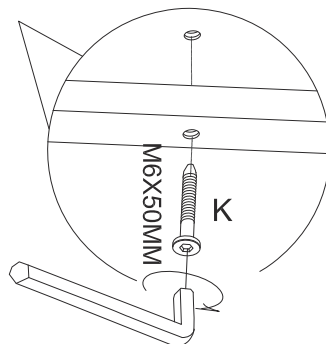
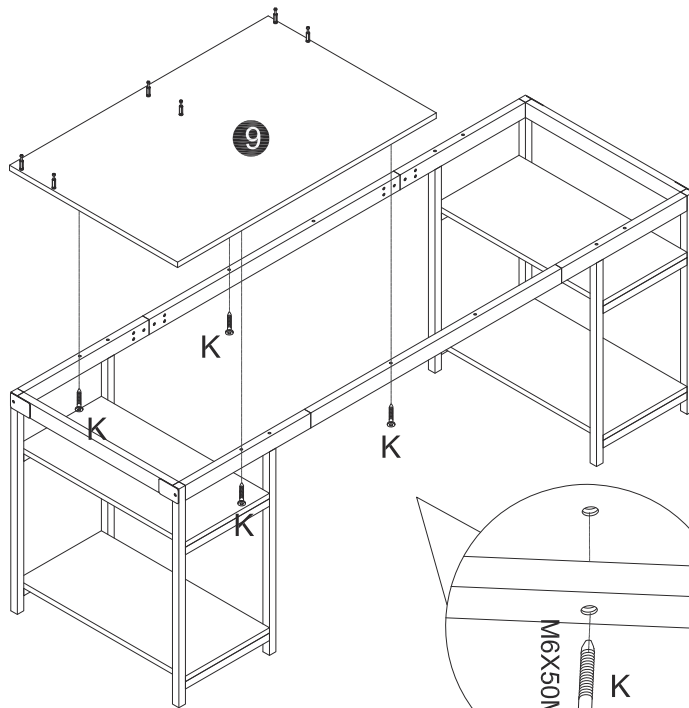

M6X50MM
K

K
4 pcs

9

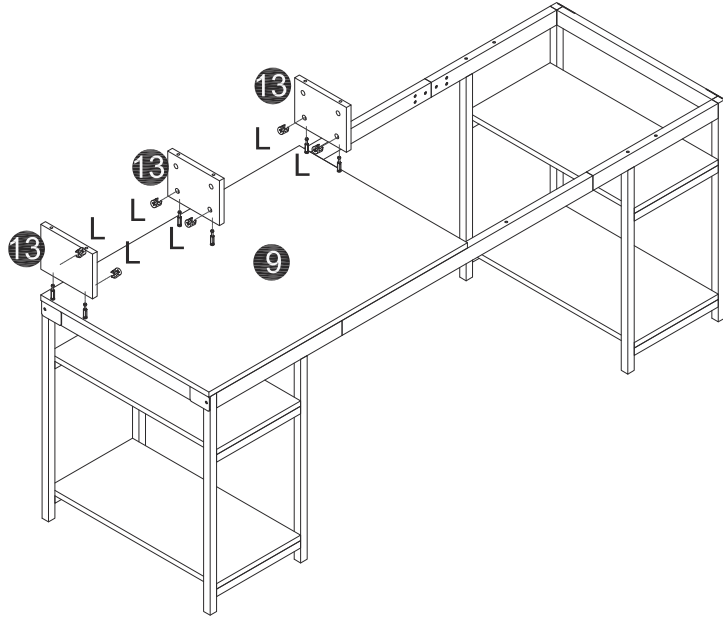
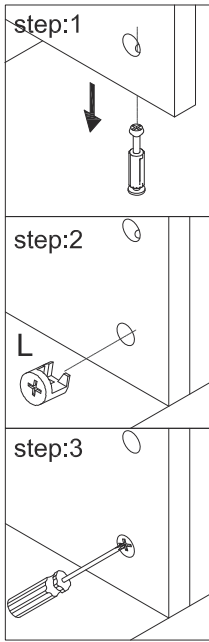

L
6 pcs

10

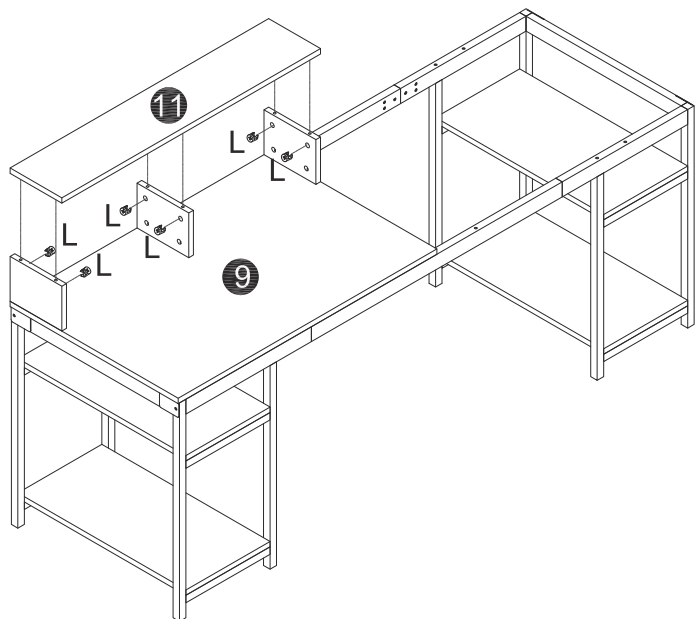
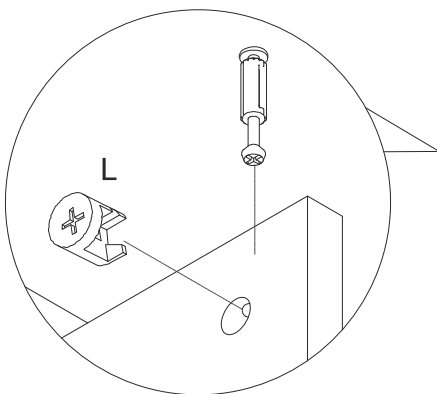

L
6 pcs

11

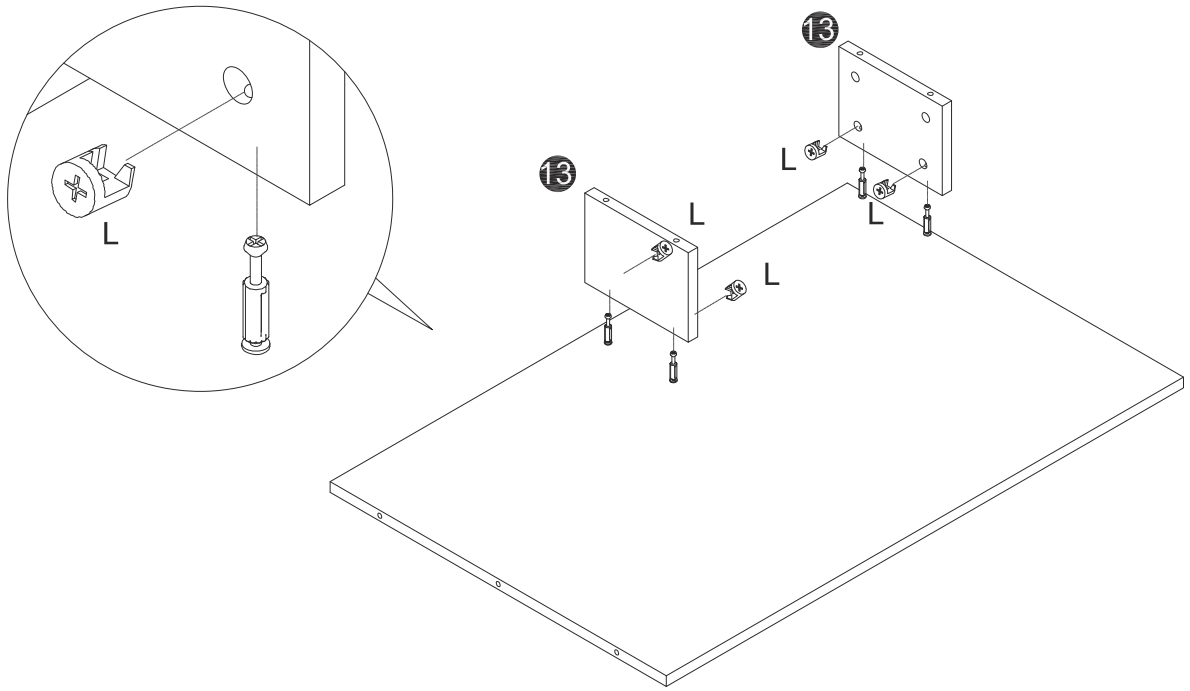

L
4 pcs

12

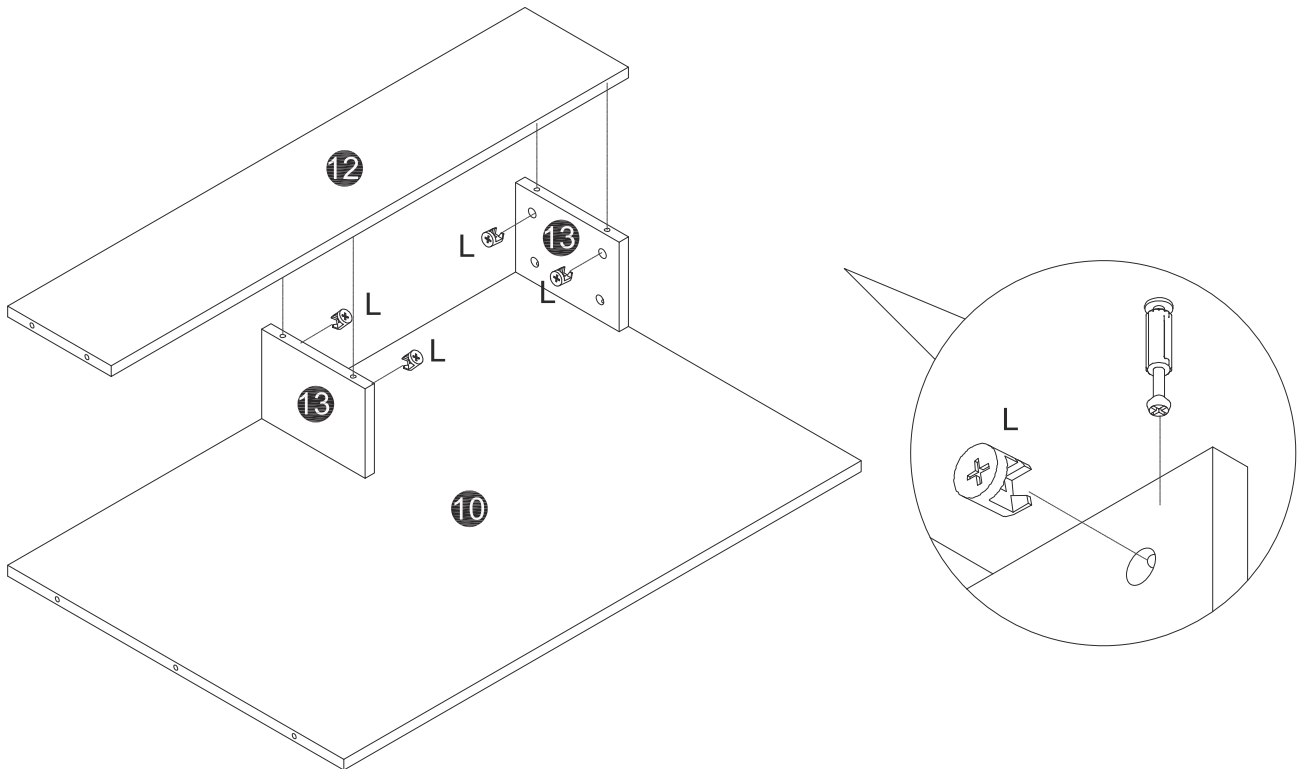

L
4 pcs

13

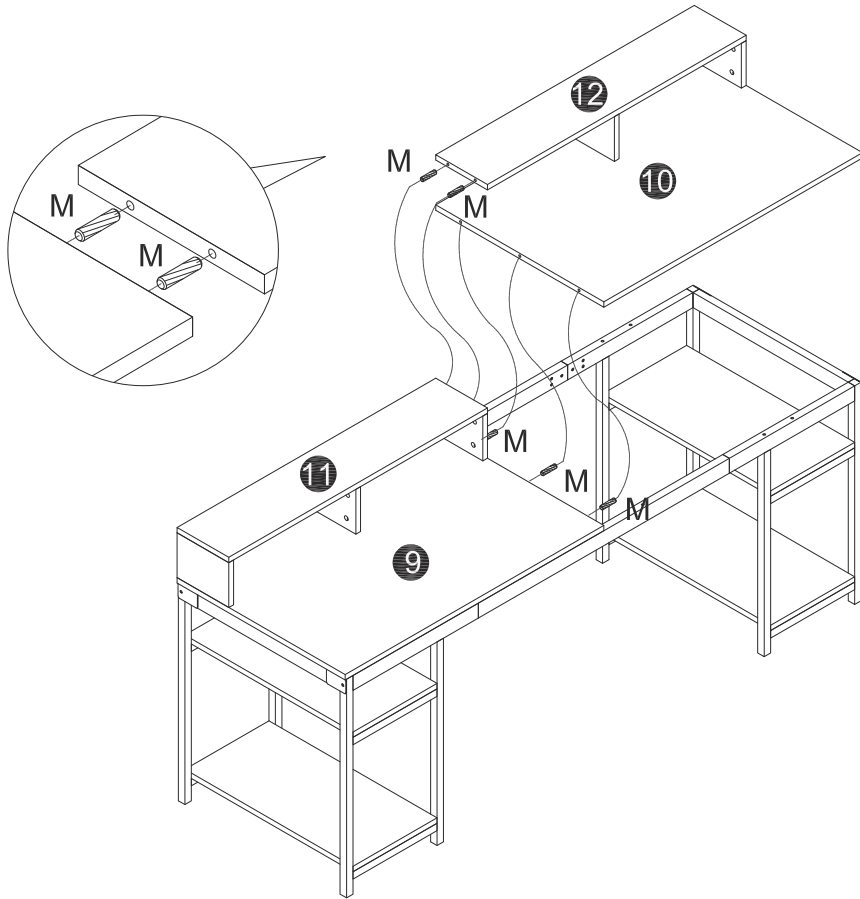

M8X40MM

M
5 pcs

14

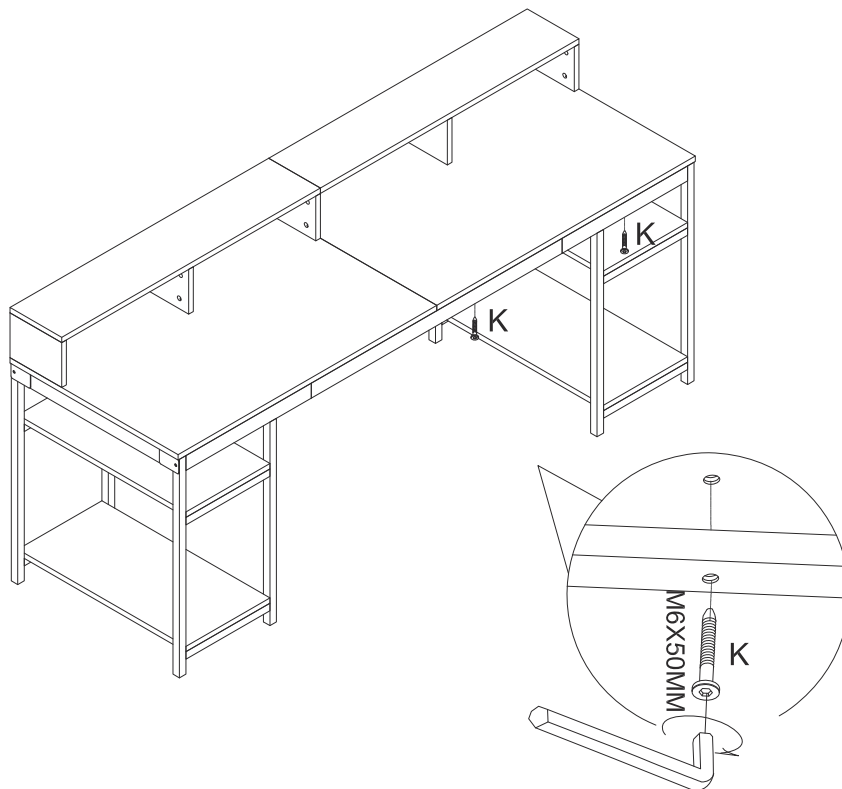

M6X50MM

K
4 pcs

Thank you for your support!

