

36" LEFT OFFSET CABINET

BASE CABINET DIMENSIONS

36" W x 21.5" D x 33.5" H



FEATURES

- Solid wood frame with engineered wood panels
- Dovetail drawers and joints
- Soft closing doors & drawers

HARDWARE FINISHES*



Brushed Nickel Satin Brass Matte Black Polished Chrome

Hardware comes preinstalled with the illustrated option. Other finishes are available on our online store if you prefer a different one.

AVAILABLE COLORS



White Grey

FRONT VIEW

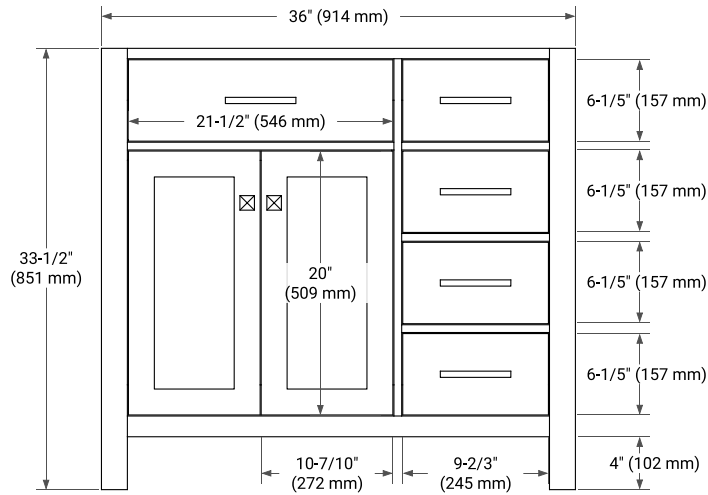

SIDE VIEW

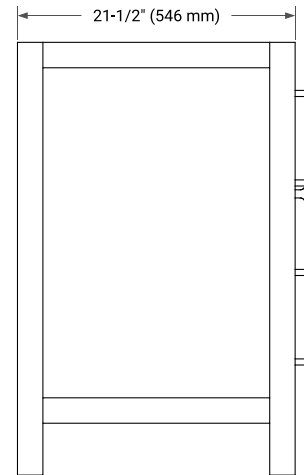

PLAN VIEW

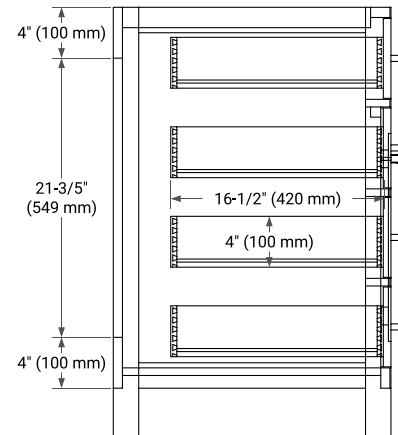
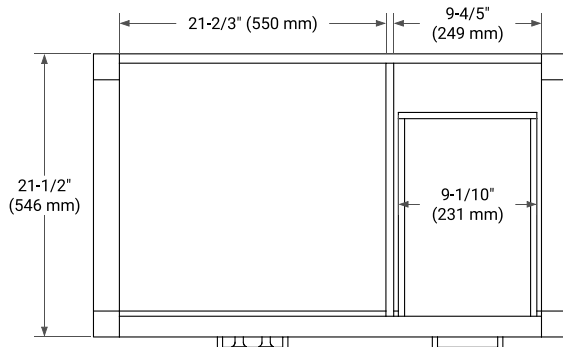

36" LEFT RECTANGLE SINK COUNTERTOP WITH 1.5 IN. THICKNESS

OVERALL DIMENSIONS

36.25" W x 22" D x 1.5" H

COUNTERTOP OPTIONS



Carrara White Quartz

FEATURES

- Solid countertop with mitered edges & seams
- Undermount white rectangular sink
- Pre-drilled for 8" widespread faucet

INCLUDED

- Countertop
- Matching Backsplash
- Rectangle Sink

COUNTERTOP PLAN VIEW

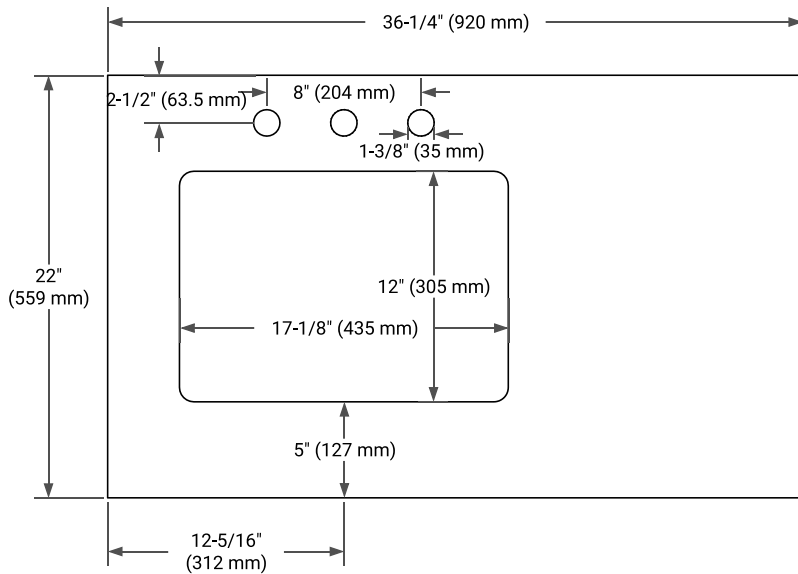

EDGE SIDE VIEW

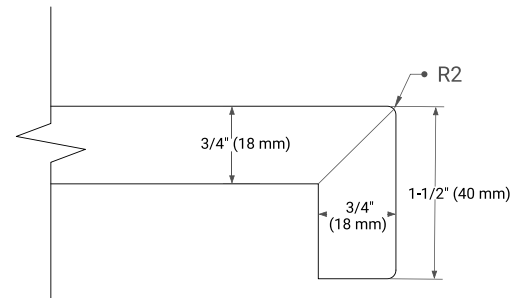

THREE DIMENSIONAL COUNTERTOP VIEW

