

Please check contents **before** assembly. If any items are missing or damaged, **do not take the unit back to the store.**

COMPONENTS

Preassembled Chair Back

1 Left Front Leg
26" Long

1 Right Front Leg
26" Long

2 Back Legs
26" Long

Preassembled Seat

2 Chair Arms

2 Rockers

2 Leg Braces

NOTE: Cracks or Checks in logs are part of the natural beauty of cedar logs and should not be considered defects.

HARDWARE
(Shown smaller than actual size)

Fourteen 2 1/2" Screws

Four 1/4" x 3" Hex Washer Head Screw*

* Lag Screws and Washers may be substituted for Hex Washer Head Screws

TOOLS REQUIRED

Rubber Mallet

Block of Wood & Hammer

#2 Screwdriver

7/16" Socket

Optional Power drill

NOTE:

- **Read all instructions before starting.**
- The two differences between the rocking chair and the rocking love seat are the length of the seat and back.
- Do not completely tighten any screws until the unit is fully assembled and setting on a level surface.
- Use a rubber mallet (or a block of wood between the hammer and the unit) to drive doweled ends into holes as far as possible.

TIPS

- A battery operated or electric drill will make assembly faster and easier.
- Use a good quality penetrating oil or wood deck sealer with a UV inhibitor and an anti-fungal. (Make sure product is intended for outdoor use.)
- If staining or finishing before assembling, tape off all dowel ends. (Finishes will cause the dowels to swell, making assembly difficult.)

STEP 1 Lay assembled seat on floor. Insert doweled ends of uprights on assembled back into holes on the back seat rail, adjust rights in or out as needed to properly. Do not tap on chair back with hammer. Tap uprights in or out until dowel drops into hole.

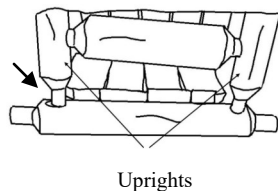

up-align

To keep the seat rail from splitting, lay the back on the floor and drive the seat onto the doweled ends by hitting on the bottom of the seat assembly.

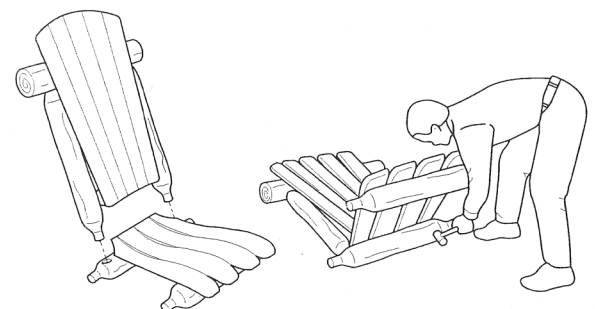

figure 1

STEP 2 Make a right leg set and a left leg set by inserting doweled end of back leg into angled hole of front leg. The drilled holes on each leg should face the same direction as shown in figure 2. Put arms onto legs by inserting doweled ends of front legs into the holes in the arms. Drive arms onto leg assemblies as far as possible.

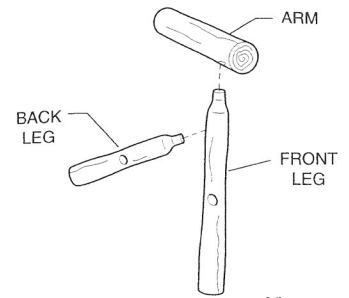

figure 2

STEP 3 Lay one leg set on a flat surface with drilled leg holes facing up. Lay back and seat assembly on its side and insert doweled ends of seat rails into holes on leg sets. Drive legs on as far as possible. Align second leg set holes with the doweled ends of the seat rails. (As shown in figure 3.) Drive legs on as far as possible.

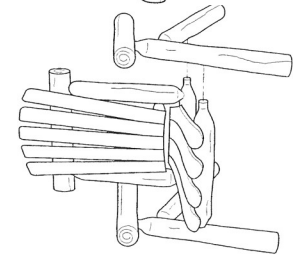

figure 3

STEP 4 Set chair in upright position on a level surface and when legs are in proper position, bring ARM in against UPRIGHT. Tighten the preinstalled lag screws into the pilot hole in the arm with a wrench or socket. Secure doweled joints in place with 2 1/2" screws perpendicular to the doweled ends as shown in figure 4 and figure 6. Repeat on other side.

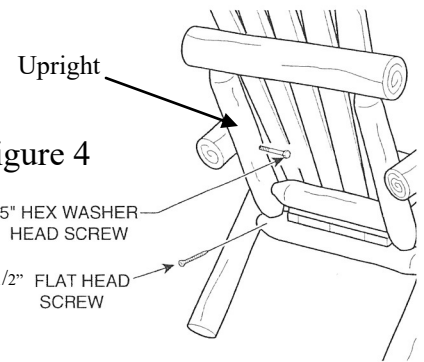

figure 4

STEP 5 Tilt chair back and screw a brace on each side of front leg to chair bottom as shown in figure 5.

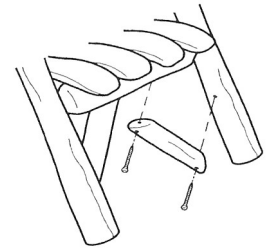

figure 5

STEP 6 Set unit on a level surface and tighten down all lag screws firmly to secure unit. Secure all doweled joints in place with screws perpendicular to the doweled ends as shown in figure 6.

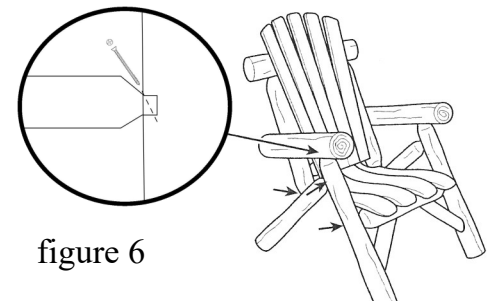
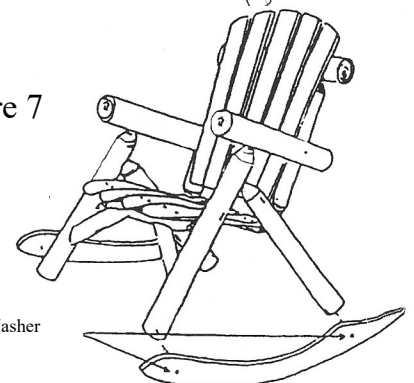

figure 6

STEP 7 Lay chair on its side and attach a rocker to legs using 1/4" x 3" Hex Washer Head Screws. Position rockers so the bottom of each leg is just above the bottom edge of the rocker. Push the hex washer head screw through the holes in the rocker and tap with a hammer to start them into each leg. You may wish to drill a small pilot hole in the leg to facilitate ease of assembly. Tighten with a 7/16" wrench. Repeat on other side.

figure 7



1/4" x 3" Hex Washer Head Screw

Your chair is now assembled and ready for finish or immediate use.

Check all joints for tightness before and during each usage season.