

VEVOR

Upgrade · The Home Creator Way

METAL END TABLE



USER MANUAL

MODEL: ZH636

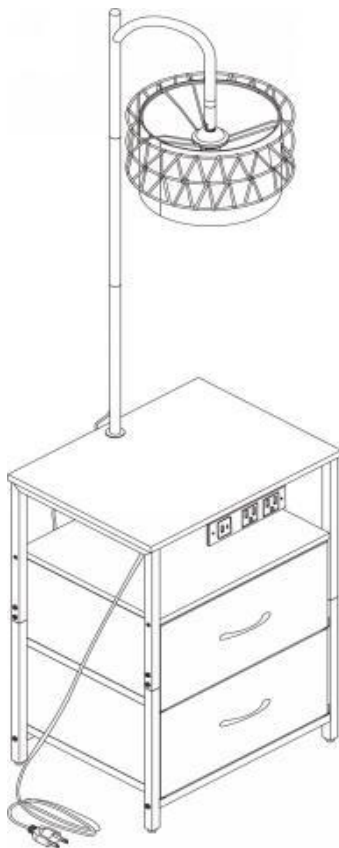
MODEL: ZH636



This is the original instruction, please read all manual instructions carefully before operating. VEVOR reserves a clear interpretation of our user manual. The appearance of the product shall be subject to the product you received. Please forgive us that we won't inform you again if there are any technology or software updates on our product.

	<p>Warning-To reduce the risk of injury, user must read instructions manual carefully.</p>
	<p>Warning- For Indoor Use Only</p>
	<p>FCC Information: CAUTION: Changes or modifications not expressly approved by the party responsible for compliance could void the user's authority to operate the equipment! This device complies with Part 15 of the FCC Rules. Operation is subject to the following two conditions: 1) This product may cause harmful interference. 2) This product must accept any interference received, including interference that may cause undesired operation.</p>

SAFETY INSTRUCTIONS

WARNING:

Read this material before using this product. Failure to do so may result in serious injury.

Assembly precautions

1. Assemble only according to these instructions. Improper assembly may create hazards.
2. Wear ANSI-approved safety goggles and heavy-duty work gloves during assembly.
3. Keep the assembly area clean and well-lit.
4. If there is/are defective and/or missing part/s after unpacking, please cease assembly immediately and get in contact with us.
5. Do not assemble if tired or when under the influence of alcohol, drugs or medication.
6. The product capabilities apply to properly and completely assembled products only.
7. Assemble on a flat, level, hard and smooth surface capable of safely supporting the metal end table.
8. If possible, you can use power tools to make assembly easier.
9. It is recommended that assembly is undertaken by at least 2 adults. Please read assembly instructions before assembly and strictly adhere to each step outlined.
10. Please note that some types of parts have a spare.
11. Use electric drill for punching holes in the wall. Carefully measure the distance between the two holes and keep them level.
12. For additional information regarding the parts listed in the following pages, please refer to the Assembly Diagram of this manual. Unwrap and separate all parts in a clean work area.

Use precautions

1. Do not exceed specified weight capacities.
2. Use only on a flat, level, hard, and smooth surface that can safely support a fully loaded metal end table.
3. Use as intended only.
4. Inspect before every use; do not use if parts are loose or damaged.
5. This product must be fixed to the wall tightly to avoid personal injury caused by falling/tilting.
6. Always securely fix the item to the wall for usage.
7. It is not intended for use by children under 5 years of age. Children must be under adult supervision to use the product.
8. It is forbidden for children to climb or play on the product to avoid serious body injury caused by the toppling.
9. During the assembly process, keep any small parts out of the reach of children. It may be fatal if swallowed or inhaled.
10. To avoid the potential dangers of suffocation, please keep all parts and packaging (films, plastic bags and foam, etc.) away from babies and children.





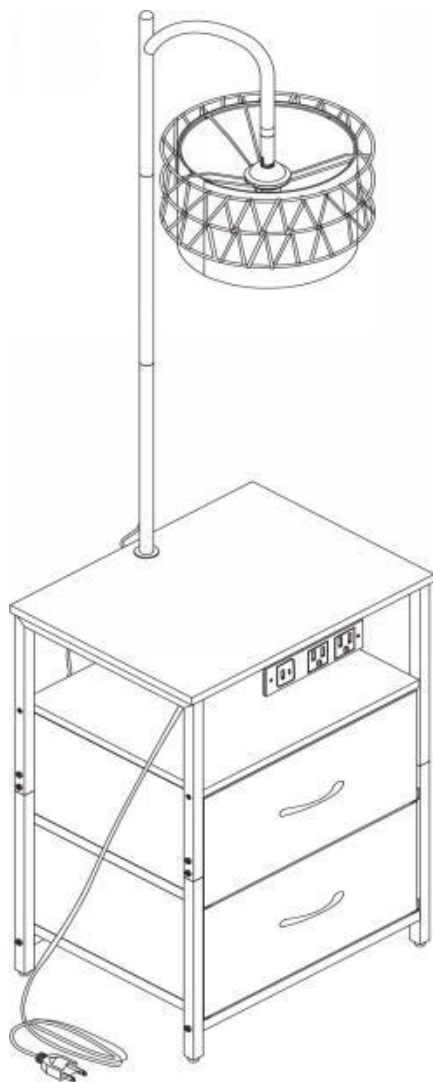

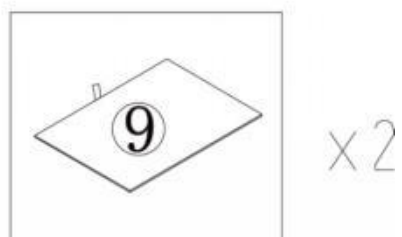
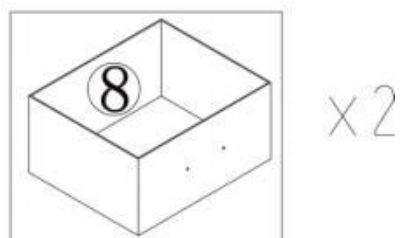
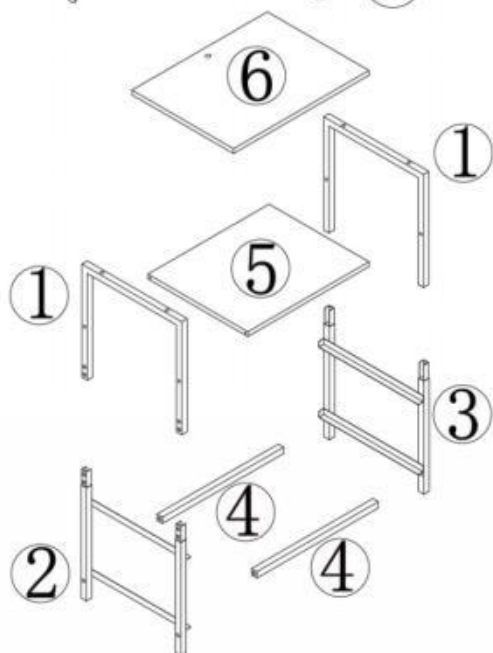
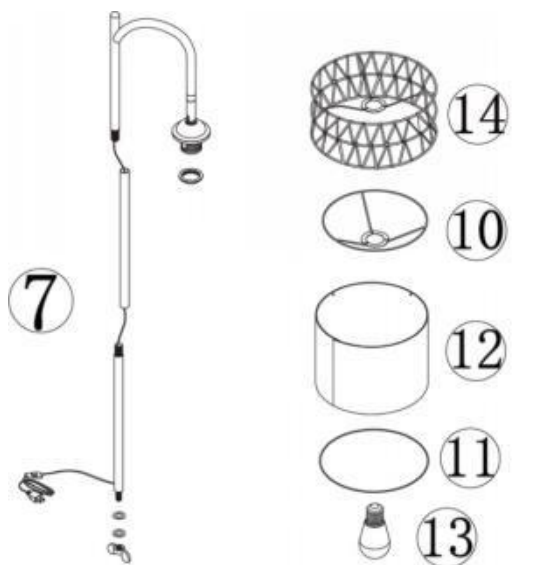

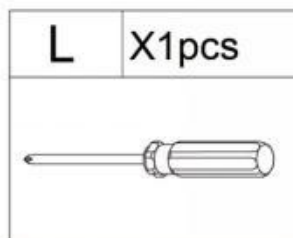
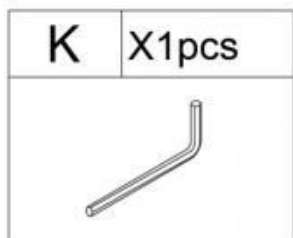
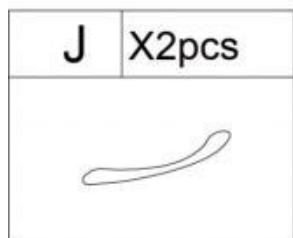
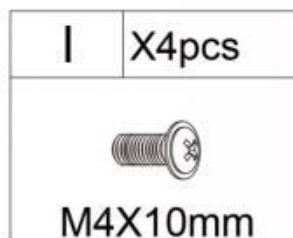
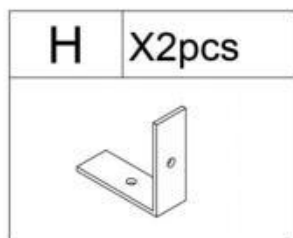
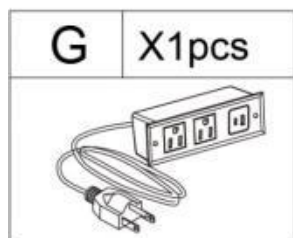
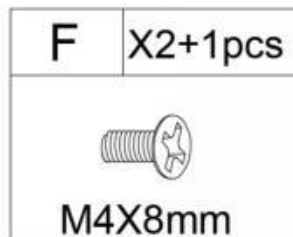
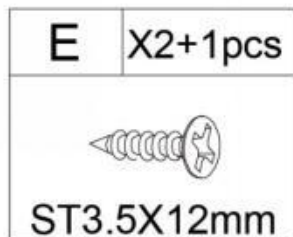
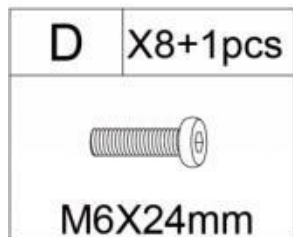
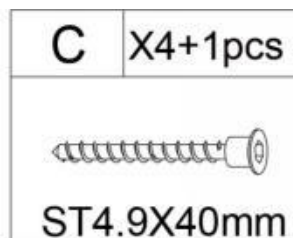
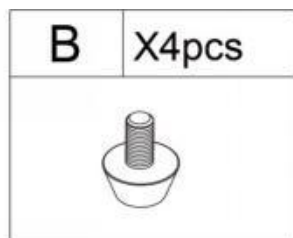
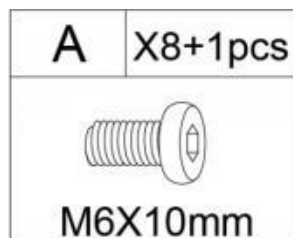

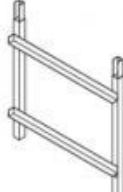

SAVE THIS MANUAL

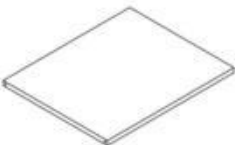
PARTS LIST

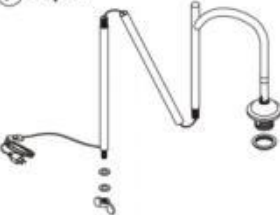
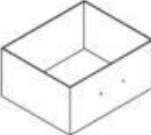





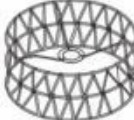

<p>① x2pcs</p> 	<p>② x1pcs</p> 	<p>③ x1pcs</p> 
<p>④ x2pcs</p> 	<p>⑤ x1pcs</p> 	<p>⑥ x1pcs</p> 
<p>⑦ x1pcs</p> 	<p>⑧ x2pcs</p> 	<p>⑨ x2pcs</p> 
<p>⑩ x1pcs</p> 	<p>⑪ x1pcs</p> 	<p>⑫ x1pcs</p> 
<p>⑬ x1pcs</p> 	<p>⑭ x1pcs</p> 	

ASSEMBLY STEP

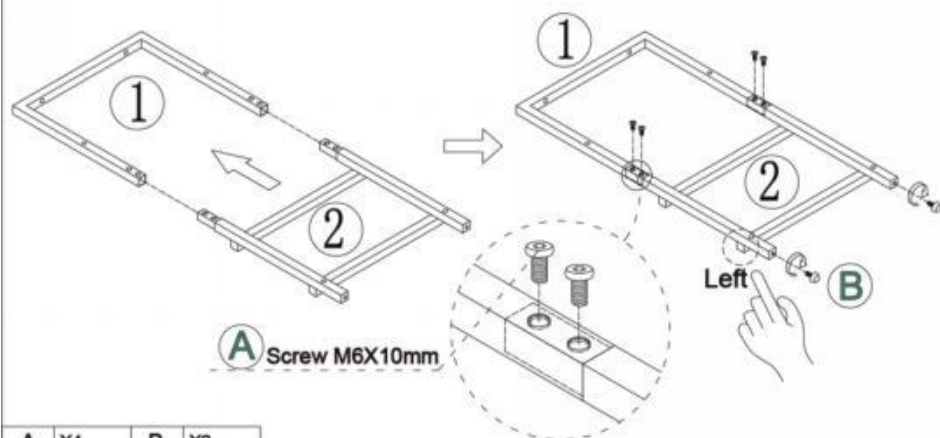

1

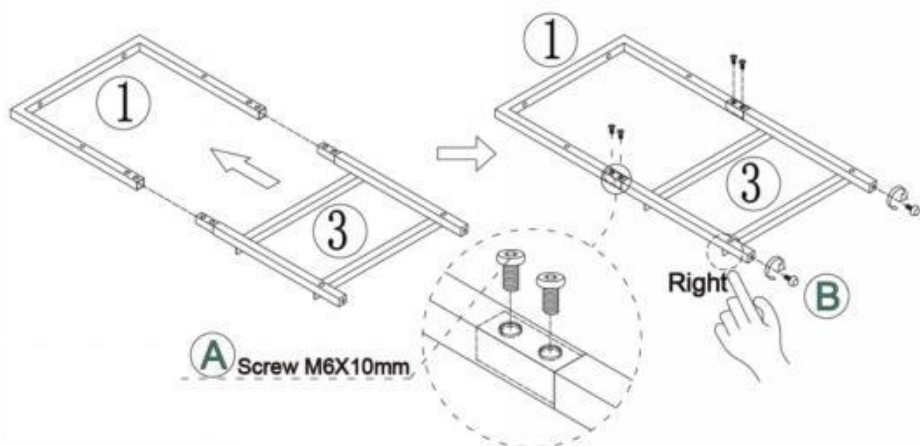

A X4	B X2
 Ø6X10mm	

2



A X4	B X2
 Ø6X10mm	

3

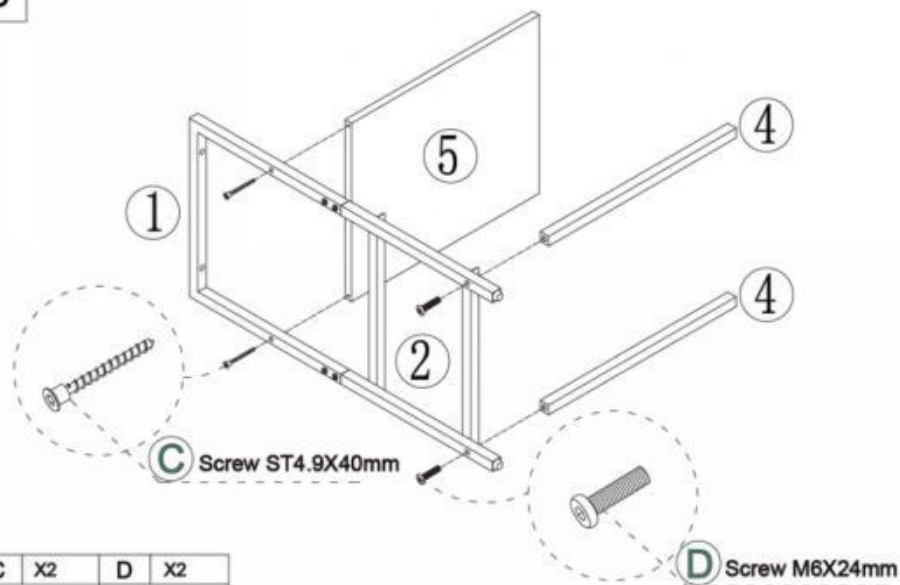

C	X2	D	X2
---	----	---	----

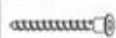

ST4.9X40mm



M6X24mm

4

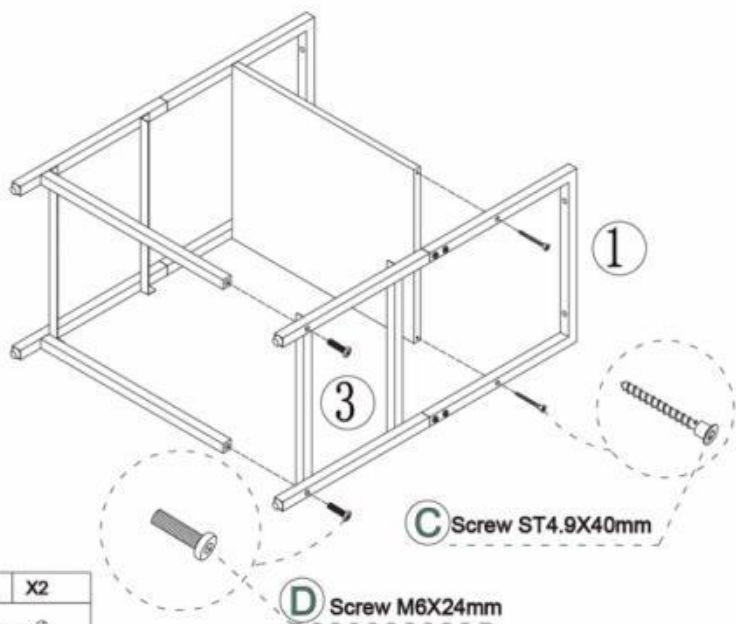

C	X2	D	X2
---	----	---	----

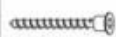





ST4.9X40mm

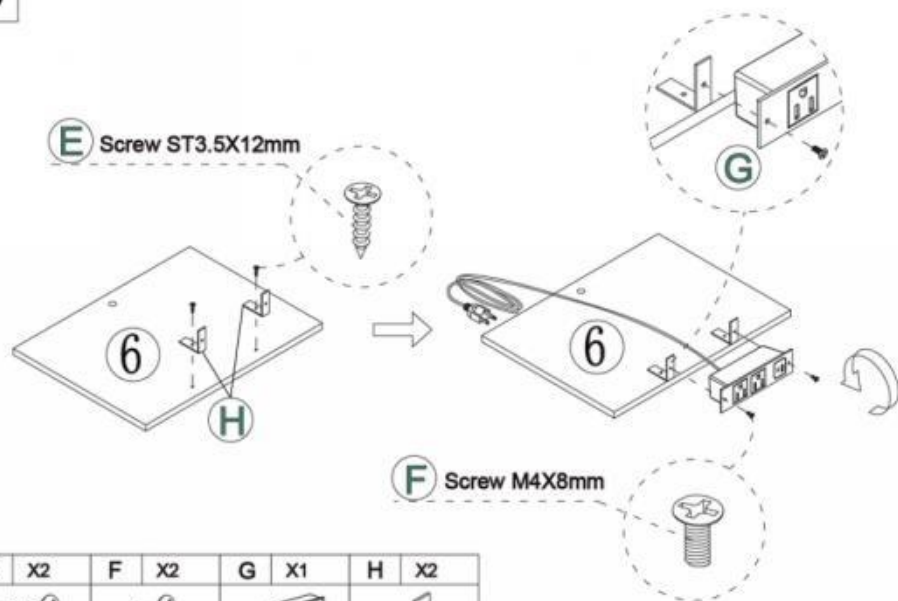

M6X24mm

5



E	X2	F	X2	G	X1	H	X2
							
ST3.5X12mm		M4X8mm					

6

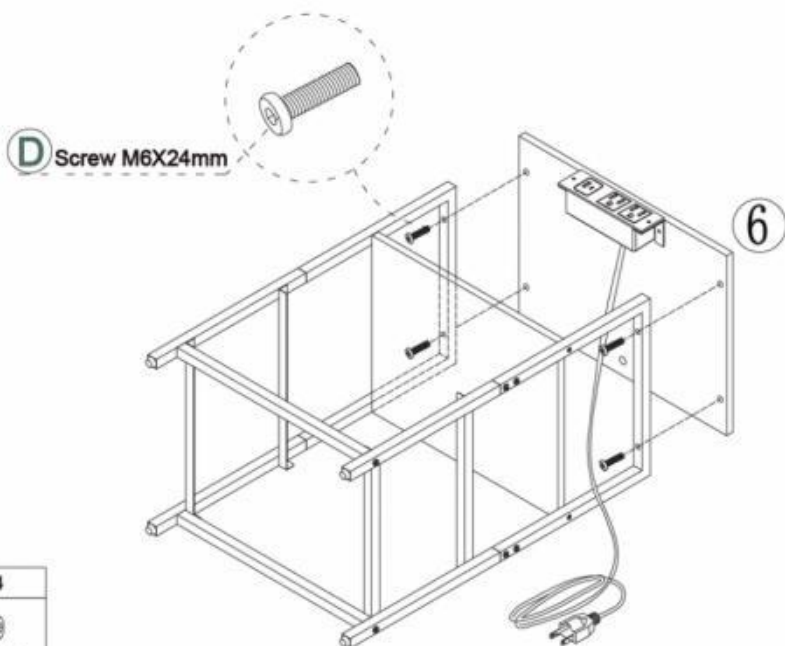

D	X4
	
M6X24mm	

7

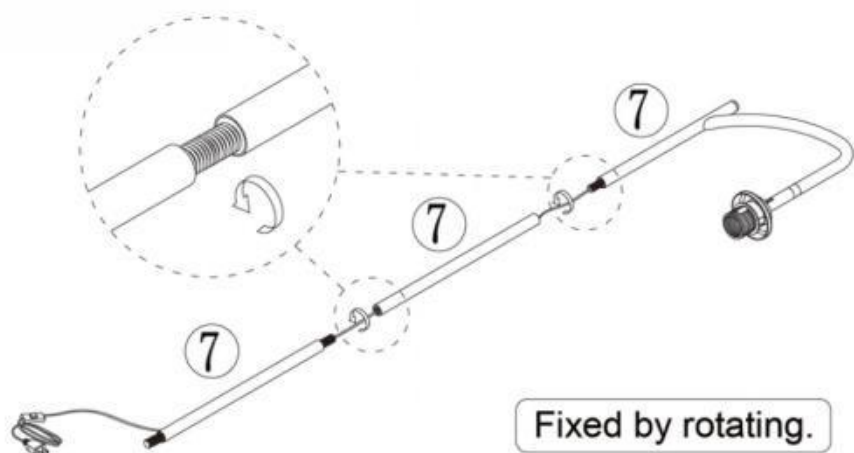

8

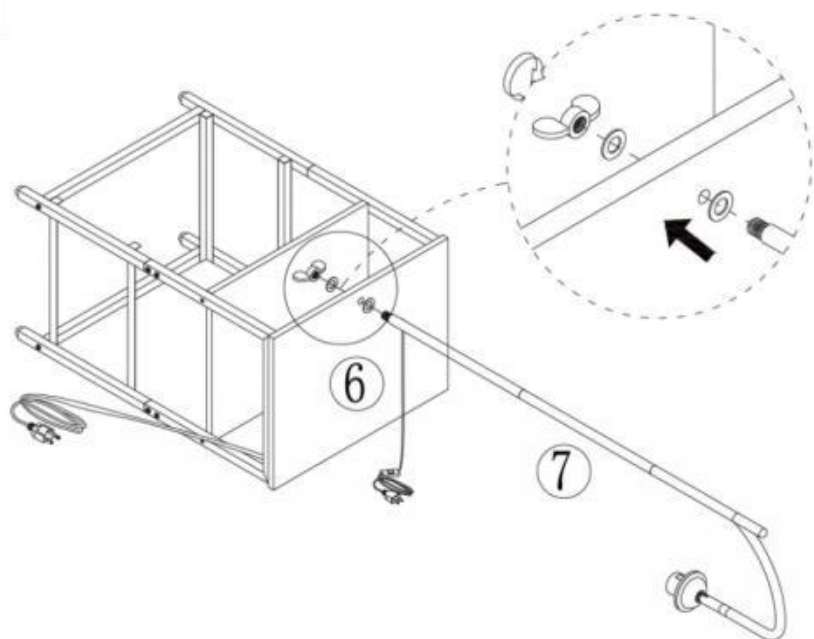

9

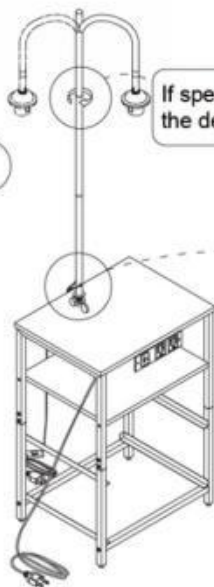

If specific circumstances arise, you can achieve the desired outcome by loosening this joint.

Installation prompt:

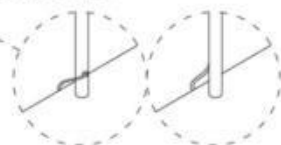

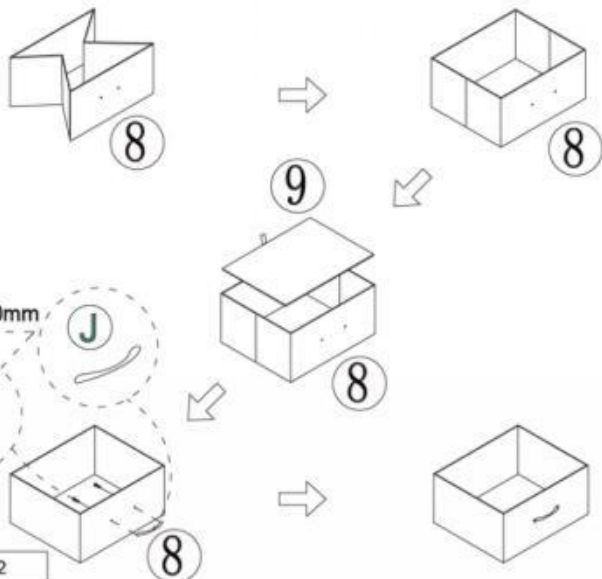

Due to the limitations of the manufacturing process, the position of the cable outlet hole may have deviations. If you have high requirements in this regard, you can wrap the tape around the threaded part in the middle of the lamp post and then try to tighten the lamp post until the outlet hole is completely aligned.

10



I Screw M4X10mm

J

I	X4	J	X2
			
M4X10mm			

X2

11

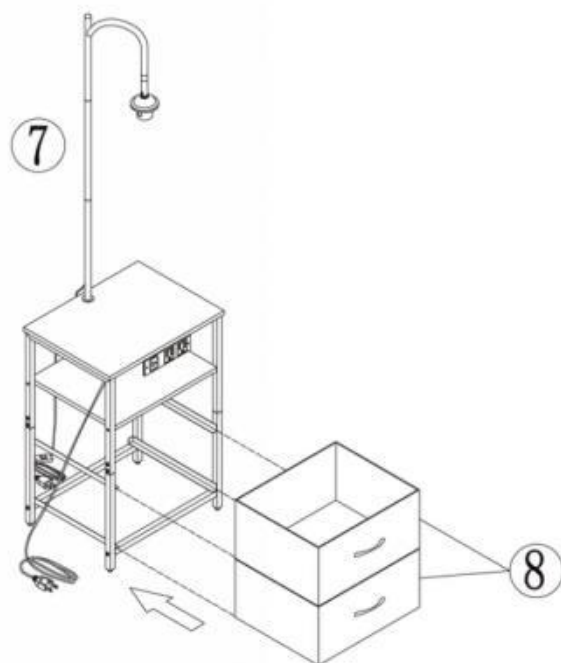

12

Installation prompt:

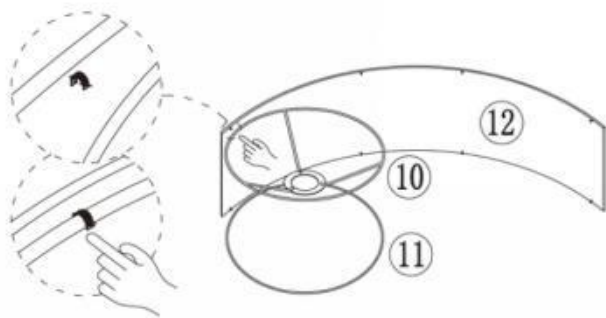

The clips at the top and bottom snap along the iron wire to hold.
The edges of the hin iron sheet are sharp, Be careful to avoid cuts.

13

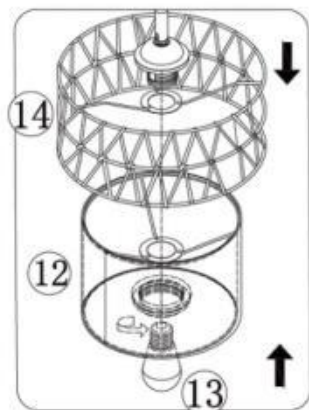
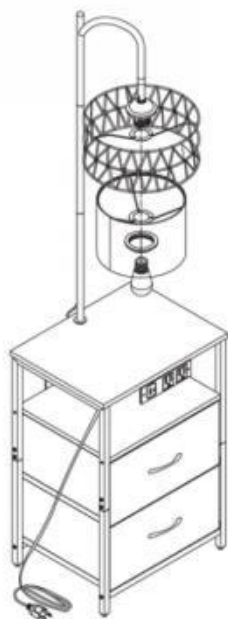

Do not power on during installation

14

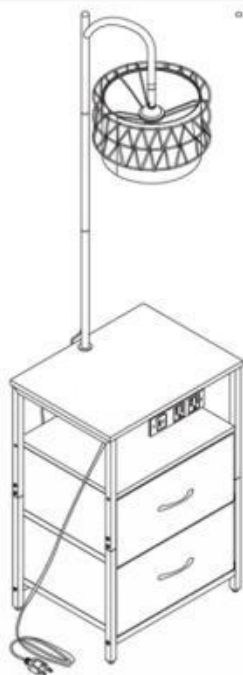

PRODUCT PARAMETER

Model	ZH636
Main Color	brown and black
Product Size (D*W*H)	400*300*1500mm
Net Weight	About 5.39kg

* Products such as specifications, appearance, and design are subject to modification without prior notice.

Manufacturer: Shanghaimuxinmuyeyouxiangongsi

Address: Shuangchenglu 803nong11hao1602A-1609shi, baoshanqu, shanghai 200000 CN.

Imported to AUS: SIHAO PTY LTD. 1 ROKEVA STREET EASTWOOD NSW 2122 Australia

Imported to USA: Sanven Technology Ltd. Suite 250, 9166 Anaheim Place, Rancho Cucamonga, CA 91730

EC	REP
-----------	------------

E-CrossStu GmbH
Mainzer Landstr.69, 60329 Frankfurt am Main.

UK	REP
-----------	------------

YH CONSULTING LIMITED.
C/O YH Consulting Limited Office 147, Centurion House, London Road, Staines-upon-Thames, Surrey, TW18 4AX



VEVOR

Upgrade · The Home Creator Way

TABLE D'APPOINT EN MÉTAL



MANUEL D' UTILISATION

MODÈLE: ZH636

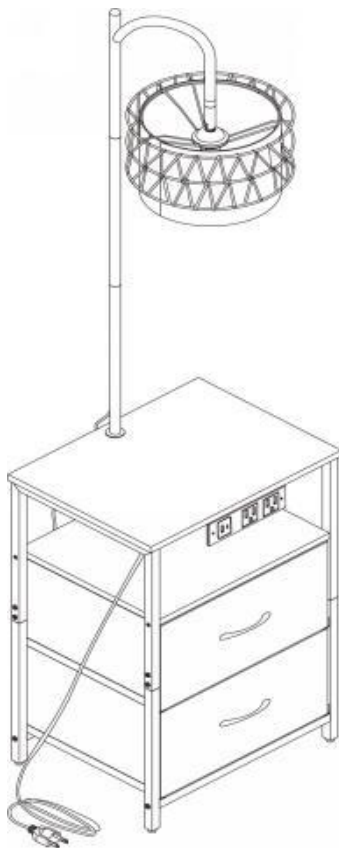
MODÈLE: ZH636



Voici le mode d'emploi original. Veuillez lire attentivement toutes les instructions du manuel avant utilisation. VEVOR se réserve le droit d'interpréter ce manuel à sa guise. L'apparence du produit que vous recevrez peut différer. Nous vous prions de nous excuser si nous ne vous informons pas des mises à jour techniques ou logicielles concernant notre produit.

	<p>Avertissement – Afin de réduire les risques de blessure, l'utilisateur doit lire attentivement le manuel d'instructions.</p>
	<p>Avertissement : Usage intérieur uniquement</p>
	<p>Informations de la FCC :</p> <p>ATTENTION : Les changements ou modifications non expressément approuvés par la partie responsable de la conformité pourraient annuler le droit de l'utilisateur à utiliser l'équipement !</p> <p>Cet appareil est conforme à la partie 15 des règles de la FCC. Son fonctionnement est soumis aux deux conditions suivantes :</p> <ol style="list-style-type: none"> 1) Ce produit peut provoquer des interférences nuisibles. 2) Ce produit doit accepter toute interférence reçue, y compris les interférences susceptibles de provoquer un fonctionnement indésirable.

SAFETY INSTRUCTIONS

AVERTISSEMENT:

Veillez lire attentivement cette notice avant d'utiliser ce produit. Le non-respect de cette consigne peut entraîner des blessures graves.

précautions d'assemblage

13. Assembler uniquement selon ces instructions. Un assemblage incorrect peut engendrer des risques.
14. Portez des lunettes de sécurité homologuées ANSI et des gants de travail robustes pendant l'assemblage.
15. Maintenez la zone de rassemblement propre et bien éclairée.
16. Si des pièces sont défectueuses et/ou manquantes après le déballage, veuillez cesser immédiatement l'assemblage et nous contacter.
17. Ne pas assembler en cas de fatigue ou sous l'influence de l'alcool, de drogues ou de médicaments.
18. Les capacités du produit s'appliquent uniquement aux produits correctement et entièrement assemblés.
19. Assembler sur une surface plane, de niveau, dure et lisse capable de supporter en toute sécurité la table d'appoint en métal.
20. Si possible, vous pouvez utiliser des outils électriques pour faciliter l'assemblage.
21. Il est recommandé que le montage soit effectué par au moins deux adultes. Veuillez lire attentivement les instructions de montage avant de procéder et suivre scrupuleusement chaque étape.
22. Veuillez noter que certains types de pièces disposent d'une pièce de rechange.
23. Utilisez une perceuse électrique pour percer les trous dans le mur. Mesurez soigneusement la distance entre les deux trous et assurez-vous qu'ils soient bien alignés.
24. Pour plus d'informations concernant les pièces mentionnées dans les pages suivantes, veuillez vous référer au schéma de montage de ce manuel. Déballiez et séparez toutes les pièces dans un espace de travail propre.

Prenez des précautions

11. Ne pas dépasser les spécifications capacités de poids.
12. À utiliser uniquement sur une surface plane, de niveau, dure et lisse pouvant supporter en toute sécurité une table d'appoint en métal entièrement chargée.
13. Utiliser uniquement conformément à l'usage prévu.
14. Inspecter avant chaque utilisation ; ne pas utiliser si des pièces sont desserrées ou endommagées.
15. Ce produit doit être solidement fixé au mur afin d'éviter les blessures corporelles dues à une chute ou à un basculement.
16. Fixez toujours solidement l'objet au mur avant utilisation.
17. Ce produit n'est pas destiné aux enfants de moins de 5 ans. Les enfants doivent être sous la surveillance d'un adulte pour l'utiliser.
18. Il est interdit aux enfants de grimper sur le produit ou de jouer dessus afin d'éviter les blessures graves pouvant résulter d'un basculement.
19. Lors du montage, veillez à tenir les petites pièces hors de portée des enfants. L'ingestion ou l'inhalation de ces pièces peut être mortelle.
- 20.** Pour éviter tout risque d'étouffement, veillez tenir toutes les pièces et l'emballage (films, sacs en plastique, mousse, etc.) hors de portée des bébés et des enfants.





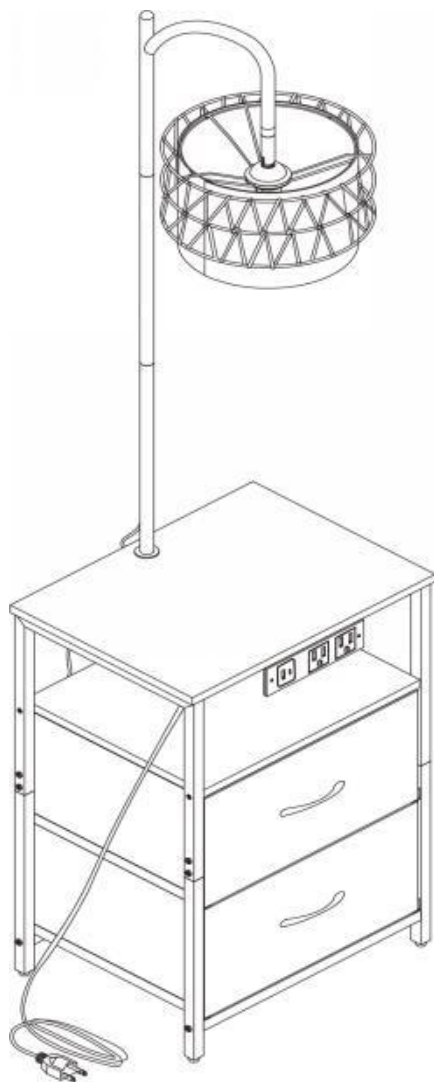

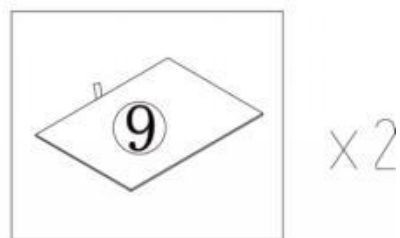
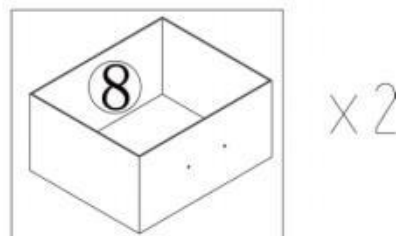
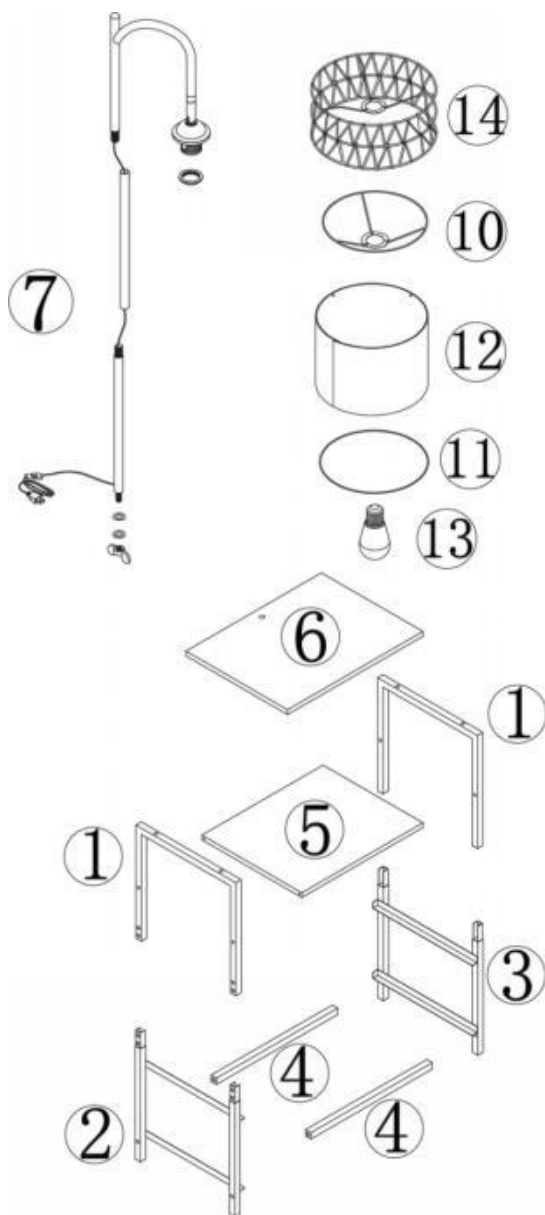

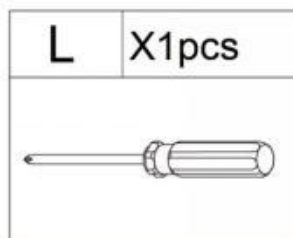
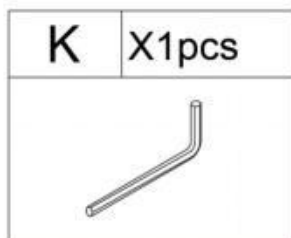
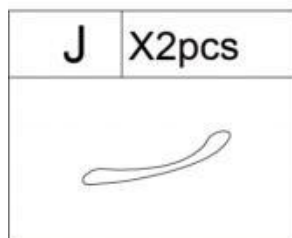
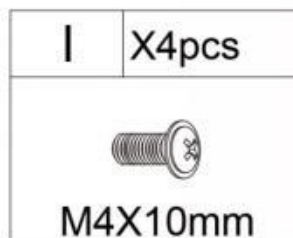
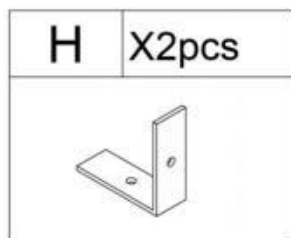
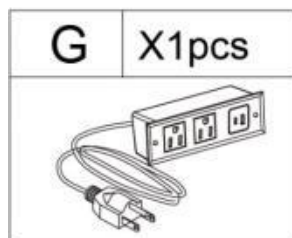
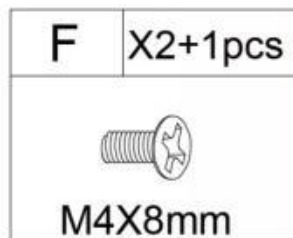
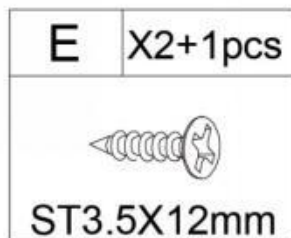
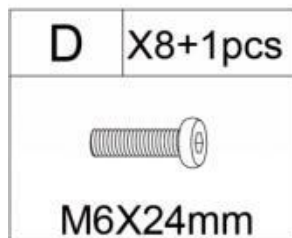
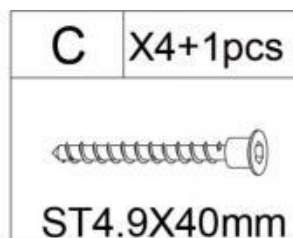
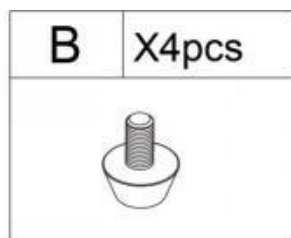
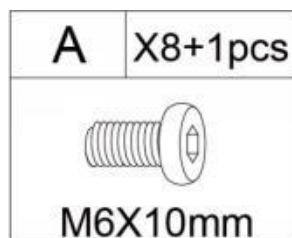

CONSERVEZ CE MANUEL

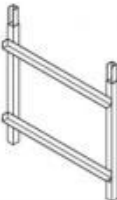
PARTS LIST



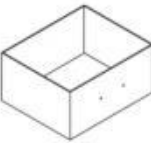
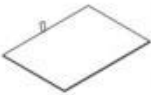

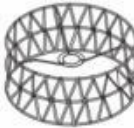

<p>① x2pcs</p> 	<p>② x1pcs</p> 	<p>③ x1pcs</p> 
<p>④ x2pcs</p> 	<p>⑤ x1pcs</p> 	<p>⑥ x1pcs</p> 
<p>⑦ x1pcs</p> 	<p>⑧ x2pcs</p> 	<p>⑨ x2pcs</p> 
<p>⑩ x1pcs</p> 	<p>⑪ x1pcs</p> 	<p>⑫ x1pcs</p> 
<p>⑬ x1pcs</p> 	<p>⑭ x1pcs</p> 	

ASSEMBLY STEP

1

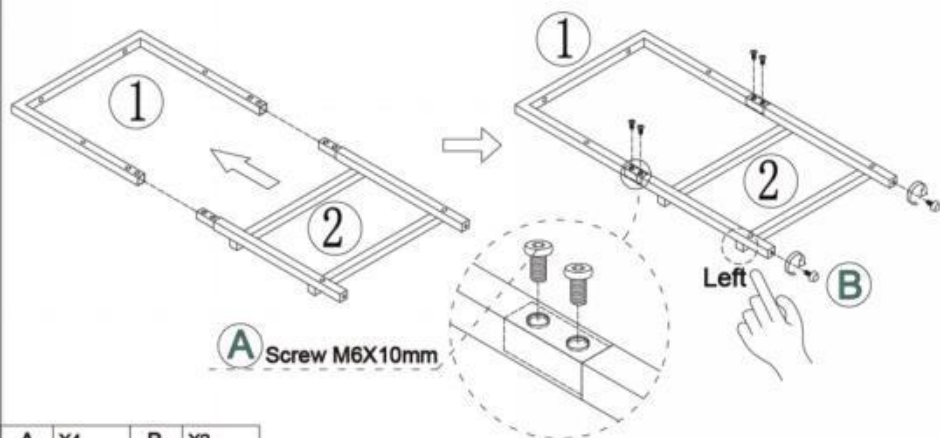

A X4

B X2



2

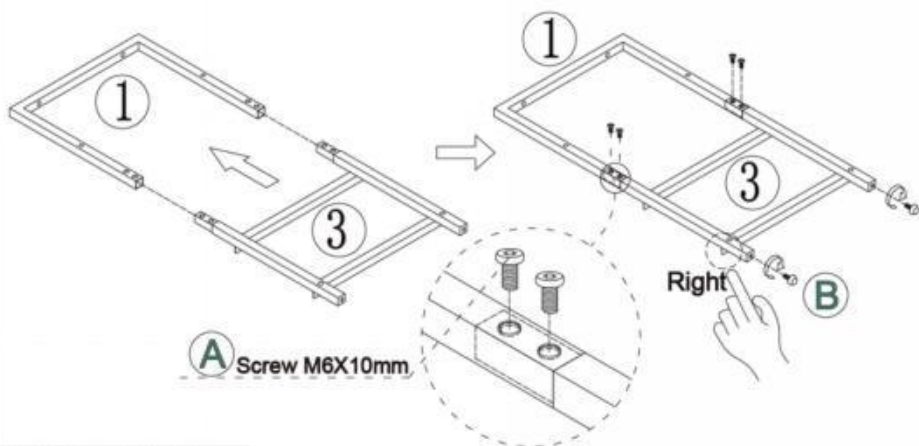

A X4

B X2



3

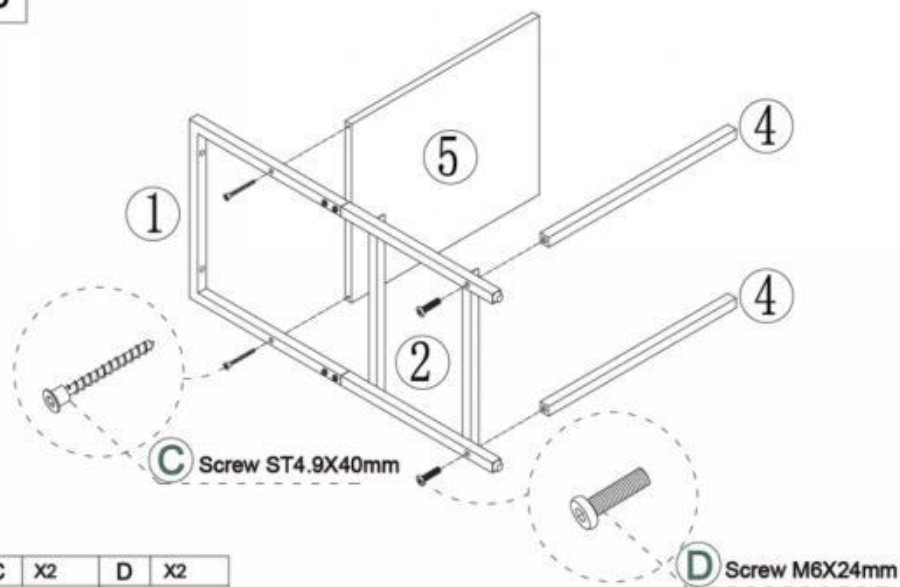

C	X2	D	X2
---	----	---	----

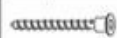

ST4.9X40mm



M6X24mm

4

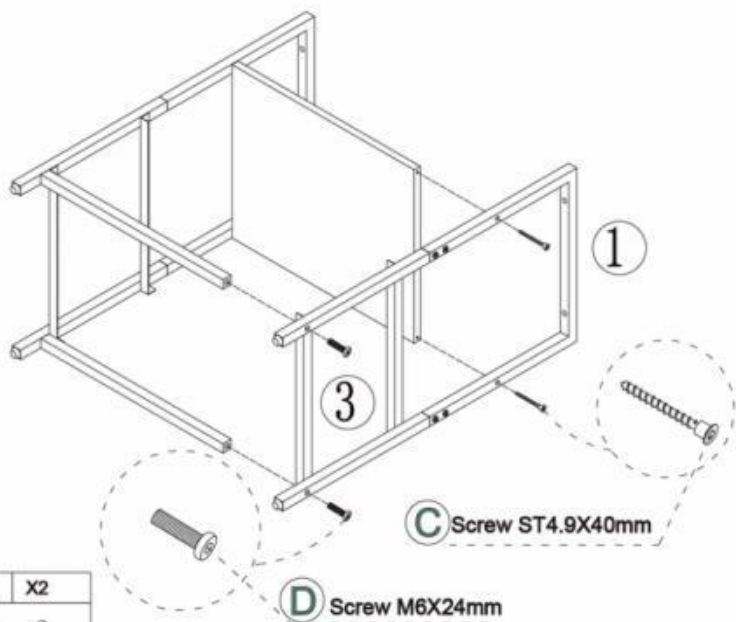

C	X2	D	X2
---	----	---	----

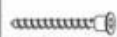



ST4.9X40mm

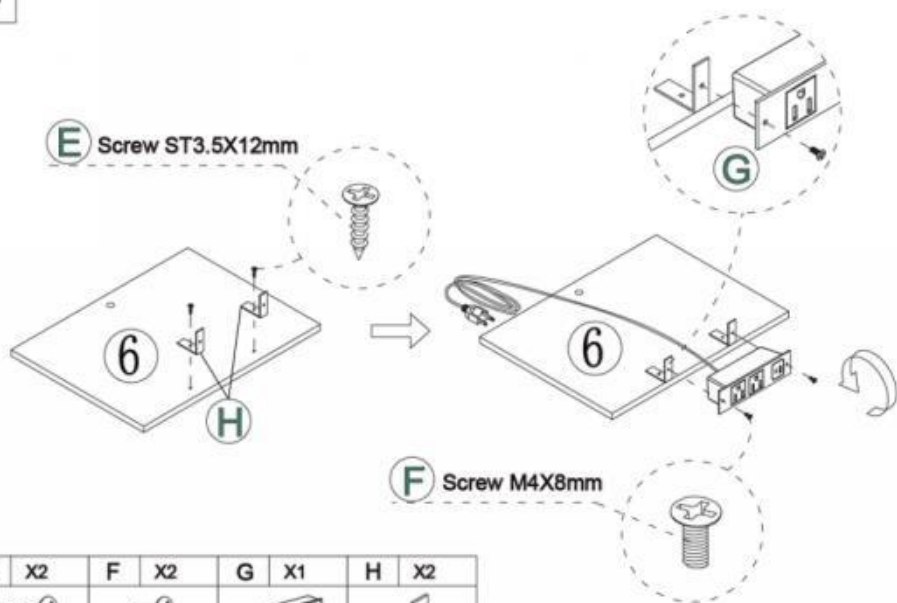

M6X24mm

5



E	X2	F	X2	G	X1	H	X2
							
ST3.5X12mm		M4X8mm					

6

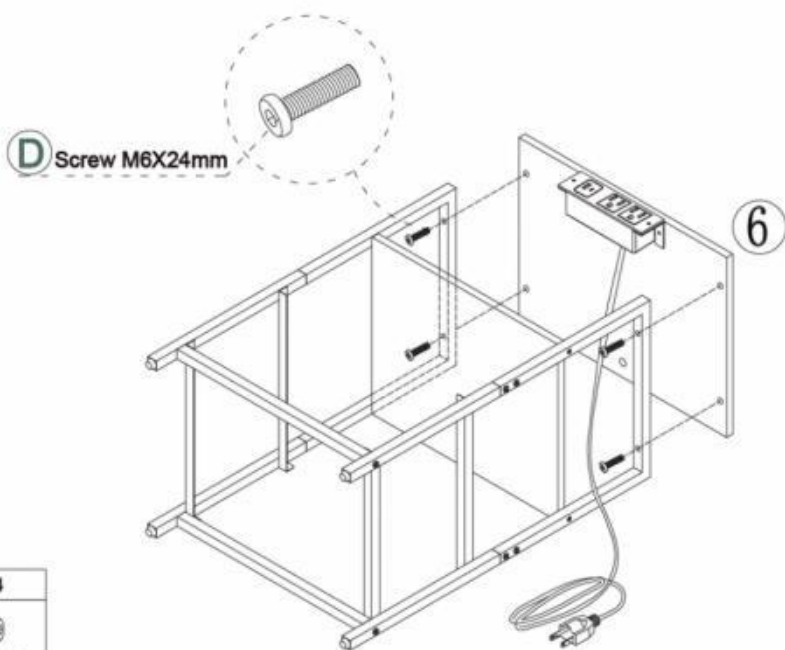

D	X4
	
M6X24mm	

7

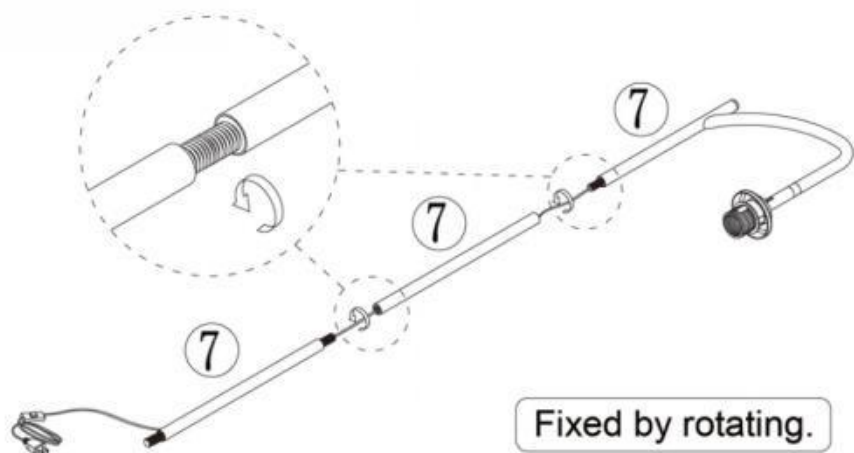

8

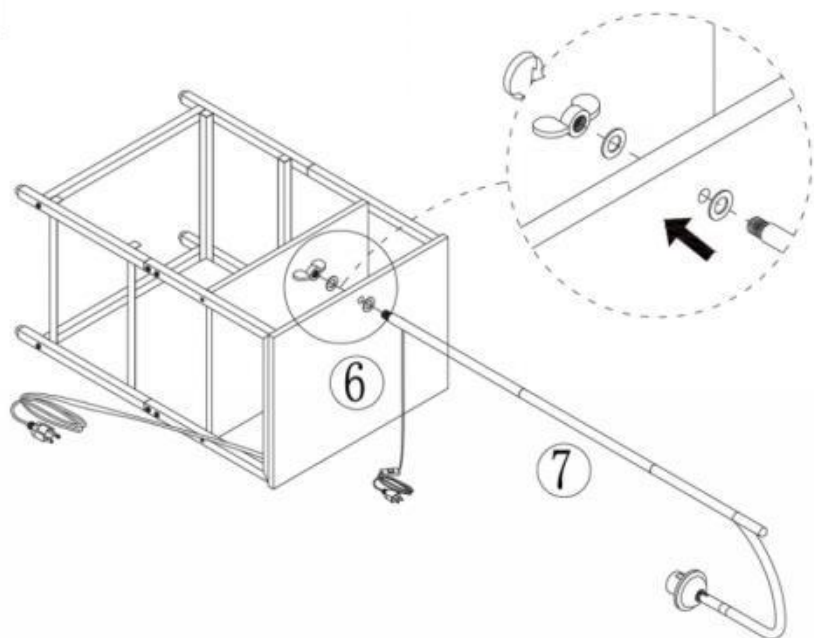

9

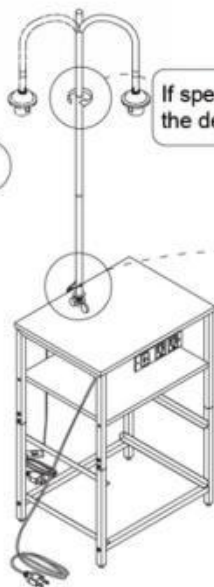

If specific circumstances arise, you can achieve the desired outcome by loosening this joint.

Installation prompt:

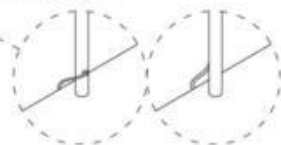

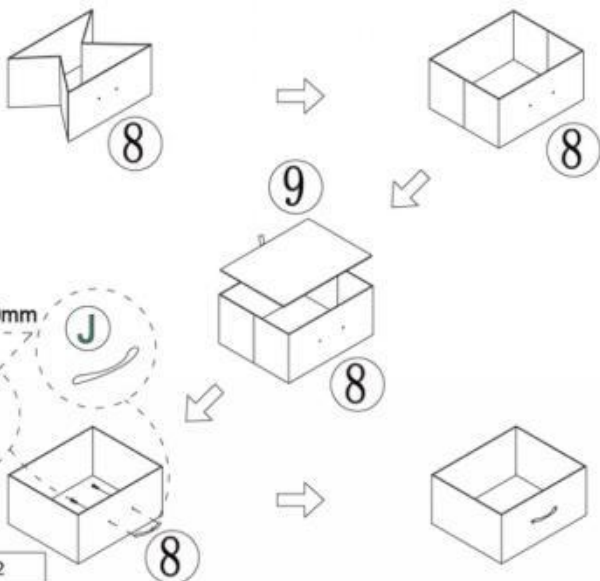

Due to the limitations of the manufacturing process, the position of the cable outlet hole may have deviations. If you have high requirements in this regard, you can wrap the tape around the threaded part in the middle of the lamp post and then try to tighten the lamp post until the outlet hole is completely aligned.

10



X2

I	X4	J	X2
			
M4X10mm			

11

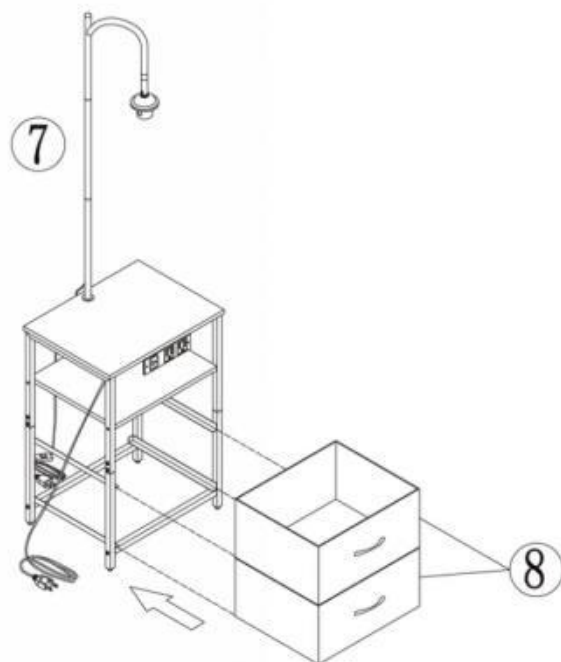

12

Installation prompt:

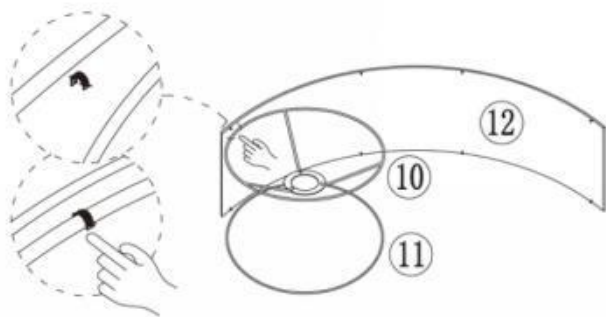

The clips at the top and bottom snap along the iron wire to hold.
The edges of the hin iron sheet are sharp, Be careful to avoid cuts.

13

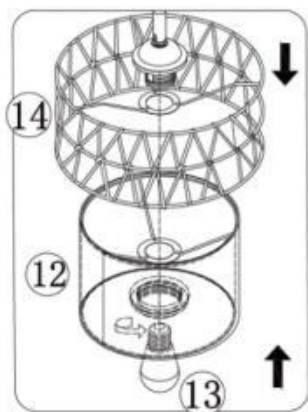
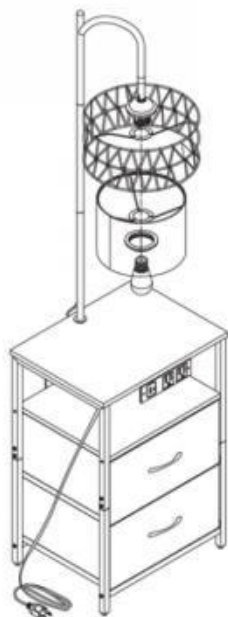

Do not power on during installation

14

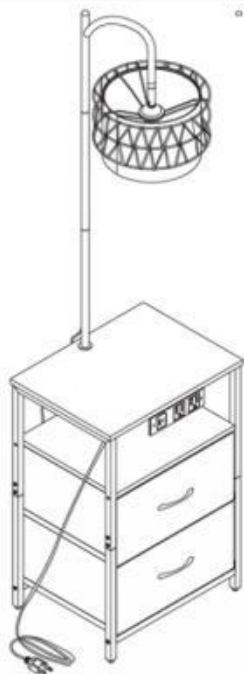

PRODUCT PARAMETER

Modèle	ZH636
Couleur principale	brun et noir
Produit Taille (P*L*H)	400*300*1500 mm
Poids net	Environ 5,39 kg

* Les caractéristiques techniques, l'apparence et le design des produits peuvent être modifiés sans préavis.

Fabricant : Shanghaimuxinmuyeyouxiangongsi

Adresse : Shuangchenglu 803nong11hao1602A-1609shi, baoshanqu, Shanghai 200000 CN.

Importé en Australie : SIHAO PTY LTD. 1 ROKEVA STREET, ESTWOOD NSW 2122, Australie

Importé aux États-Unis : Sanven Technology Ltd., Suite 250, 9166 Anaheim Place, Rancho Cucamonga, CA 91730

EC	REP
-----------	------------

E-CrossStu GmbH
Mainzer Landstr.69, 60329 Frankfurt am Main.

UK	REP
-----------	------------

YH CONSULTING LIMITED.
C/O YH Consulting Limited Office 147, Centurion House, London Road, Staines-upon-Thames, Surrey, TW18 4AX



VEVOR

Upgrade · The Home Creator Way

BEISTELLTISCH AUS METALL



BENUTZERHANDBUCH

MODELL: ZH636

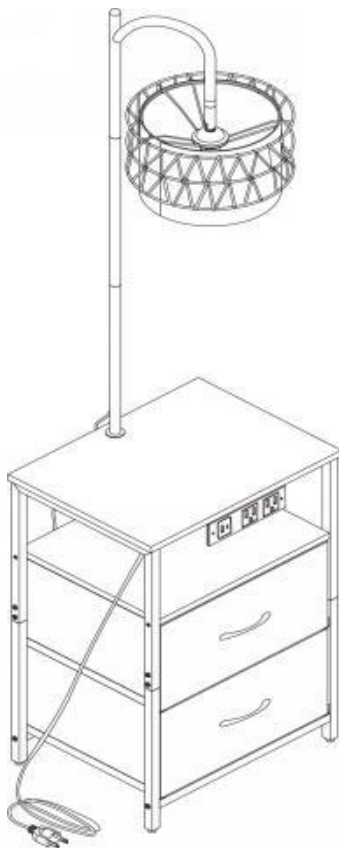
MODELL: ZH636



Dies ist die Originalanleitung. Bitte lesen Sie die gesamte Bedienungsanleitung vor der Inbetriebnahme sorgfältig durch. VEVOR behält sich die Auslegung der Bedienungsanleitung vor. Das Aussehen des Produkts kann von dem gelieferten Produkt abweichen. Wir bitten um Verständnis, dass wir Sie nicht erneut über etwaige Technologie- oder Software-Updates informieren werden .

	<p>Warnung – Um das Verletzungsrisiko zu verringern, muss der Benutzer die Bedienungsanleitung sorgfältig lesen.</p>
	<p>Warnung – Nur für den Gebrauch in Innenräumen</p>
	<p>FCC-Informationen: VORSICHT: Änderungen oder Modifikationen, die nicht ausdrücklich von der für die Einhaltung der Vorschriften verantwortlichen Partei genehmigt wurden, können zum Erlöschen der Berechtigung des Benutzers zum Betrieb des Geräts führen! Dieses Gerät entspricht Teil 15 der FCC-Bestimmungen. Der Betrieb unterliegt den folgenden zwei Bedingungen:</p> <ol style="list-style-type: none"> 1) Dieses Produkt kann schädliche Störungen verursachen. 2) Dieses Produkt muss alle empfangenen Störungen akzeptieren, einschließlich solcher, die einen unerwünschten Betrieb verursachen können.

SAFETY INSTRUCTIONS

WARNUNG:

Lesen Sie diese Hinweise vor der Verwendung dieses Produkts. Andernfalls kann es zu schweren Verletzungen kommen.

Vorsichtsmaßnahmen bei Versammlungen

25. Bitte montieren Sie das Produkt ausschließlich gemäß dieser Anleitung. Eine unsachgemäße Montage kann Gefahren bergen.
26. Tragen Sie während der Montage eine ANSI-geprüfte Schutzbrille und robuste Arbeitshandschuhe.
27. Halten Sie den Montagebereich sauber und gut beleuchtet.
28. Sollten nach dem Auspacken defekte und/oder fehlende Teile vorhanden sein, unterbrechen Sie bitte sofort die Montage und setzen Sie sich mit uns in Verbindung.
29. Nicht montieren, wenn Sie müde sind oder unter dem Einfluss von Alkohol, Drogen oder Medikamenten stehen.
30. Die Produkteigenschaften gelten nur für ordnungsgemäß und vollständig montierte Produkte.
31. Montieren Sie den Metallbeistelltisch auf einer ebenen, harten und glatten Oberfläche, die den Tisch sicher tragen kann.
32. Falls möglich, können Sie Elektrowerkzeuge verwenden, um die Montage zu erleichtern.
33. Es wird empfohlen, die Montage von mindestens zwei Erwachsenen durchführen zu lassen. Bitte lesen Sie die Montageanleitung vor der Montage sorgfältig durch und befolgen Sie jeden einzelnen Schritt genau.
34. Bitte beachten Sie, dass einige Teile als Ersatzteile erhältlich sind.
35. Verwenden Sie eine elektrische Bohrmaschine, um Löcher in die Wand zu bohren. Messen Sie sorgfältig den Abstand zwischen den beiden Löchern und achten Sie darauf, dass sie waagrecht sind.
36. Weitere Informationen zu den auf den folgenden Seiten aufgeführten Teilen finden Sie in der Montagezeichnung dieses Handbuchs. Packen Sie alle Teile in einem sauberen Arbeitsbereich aus und trennen Sie

sie.

Vorsicht walten lassen

21. Die angegebenen Werte dürfen nicht überschritten werden. Tragfähigkeiten.
22. Nur auf einer ebenen, harten und glatten Oberfläche verwenden, die einen voll beladenen Beistelltisch aus Metall sicher tragen kann.
23. Nur bestimmungsgemäß verwenden.
24. Vor jedem Gebrauch prüfen; nicht verwenden, wenn Teile lose oder beschädigt sind.
25. Dieses Produkt muss fest an der Wand befestigt werden, um Verletzungen durch Herunterfallen/Kippen zu vermeiden.
26. Befestigen Sie den Gegenstand vor Gebrauch stets sicher an der Wand.
27. Es ist nicht für Kinder unter 5 Jahren geeignet. Kinder dürfen das Produkt nur unter Aufsicht von Erwachsenen verwenden.
28. Es ist Kindern untersagt, auf dem Produkt zu klettern oder darauf zu spielen, um schwere Verletzungen durch Umkippen zu vermeiden.
29. Achten Sie während der Montage darauf, dass Kleinteile für Kinder unzugänglich bleiben. Verschlucken oder Einatmen kann tödlich sein.
- 30.** Um die mögliche Erstickungsgefahr zu vermeiden, bewahren Sie bitte alle Teile und Verpackungen (Folien, Plastiktüten, Schaumstoff usw.) außerhalb der Reichweite von Babys und Kindern auf.





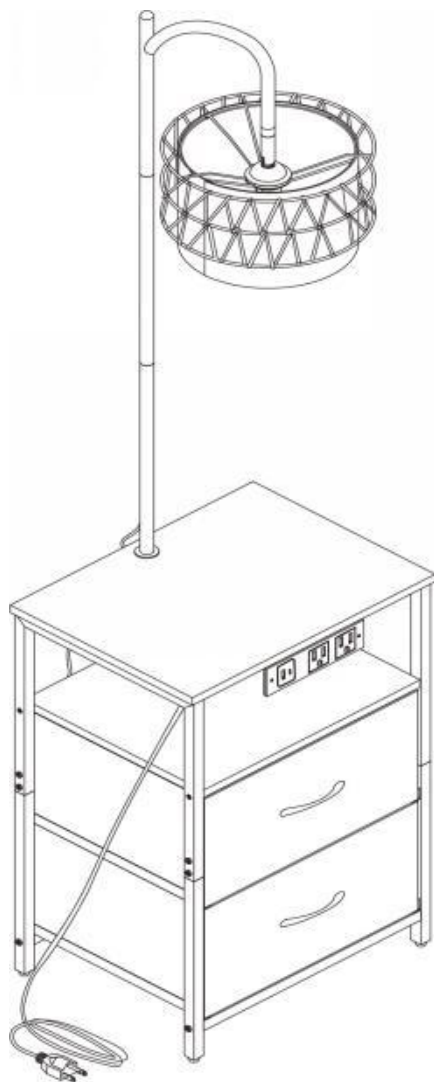

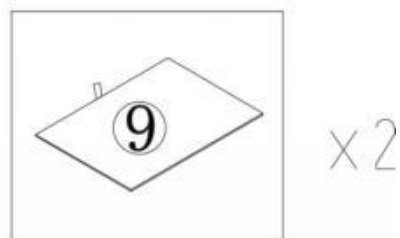
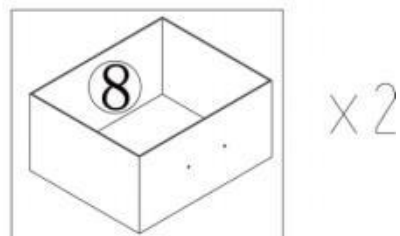
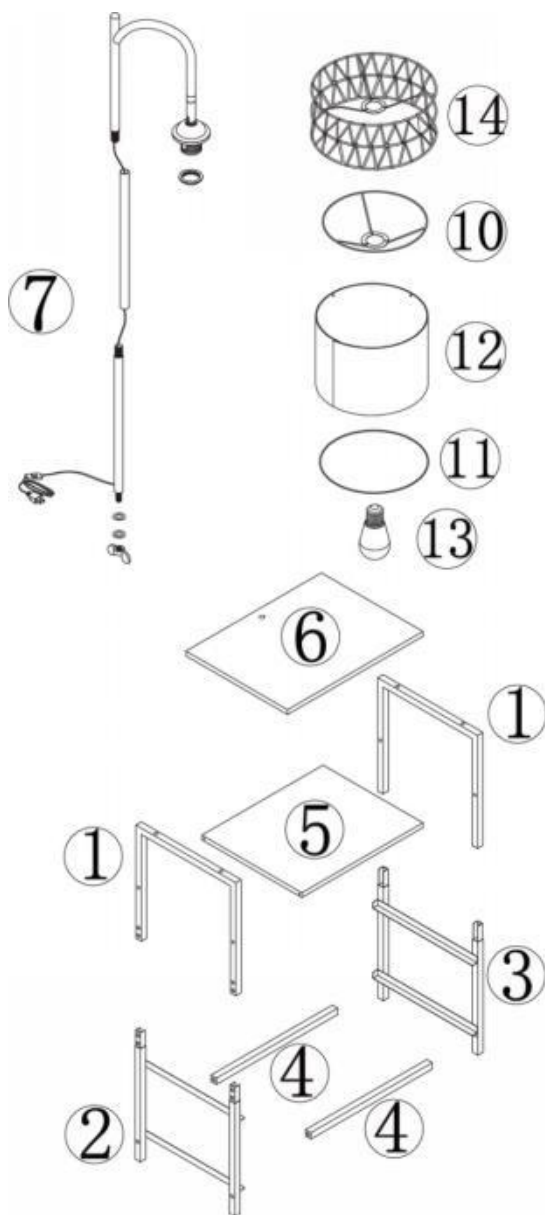

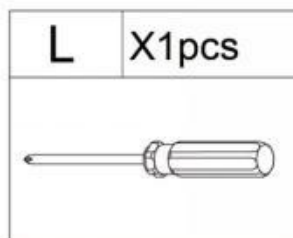
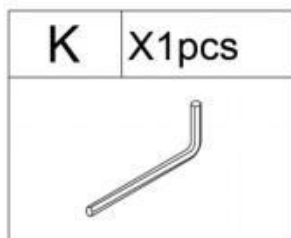
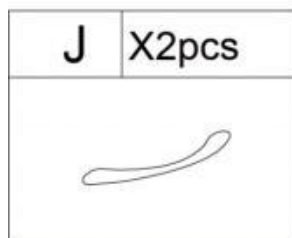
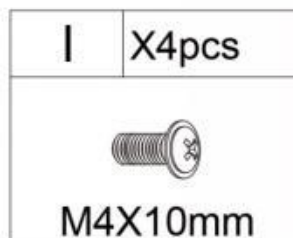
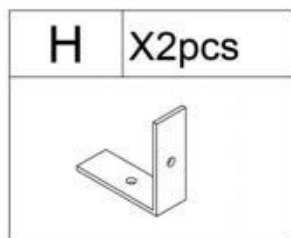
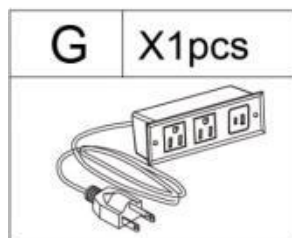
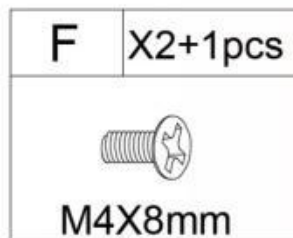
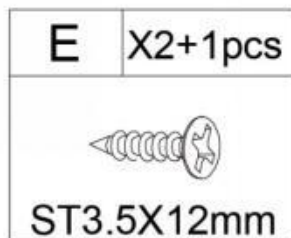
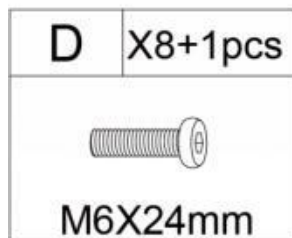
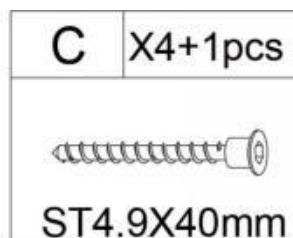
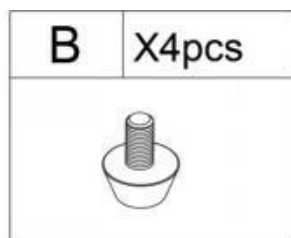
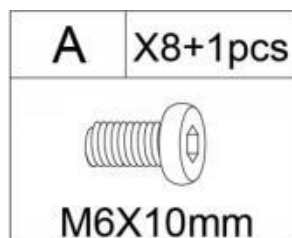

BEWAHREN SIE DIESES HANDBUCH AUF

PARTS LIST



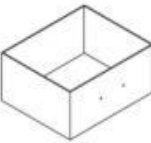
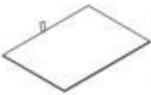

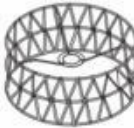

<p>① x2pcs</p> 	<p>② x1pcs</p> 	<p>③ x1pcs</p> 
<p>④ x2pcs</p> 	<p>⑤ x1pcs</p> 	<p>⑥ x1pcs</p> 
<p>⑦ x1pcs</p> 	<p>⑧ x2pcs</p> 	<p>⑨ x2pcs</p> 
<p>⑩ x1pcs</p> 	<p>⑪ x1pcs</p> 	<p>⑫ x1pcs</p> 
<p>⑬ x1pcs</p> 	<p>⑭ x1pcs</p> 	

ASSEMBLY STEP

1

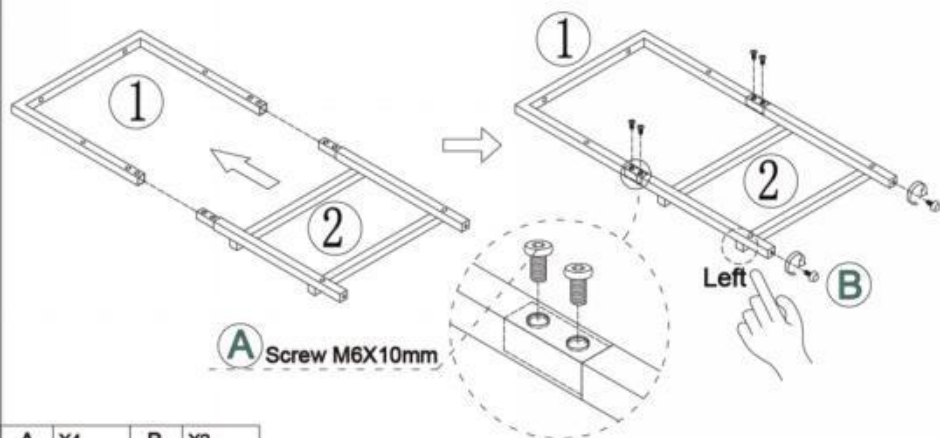

A X4

B X2



2

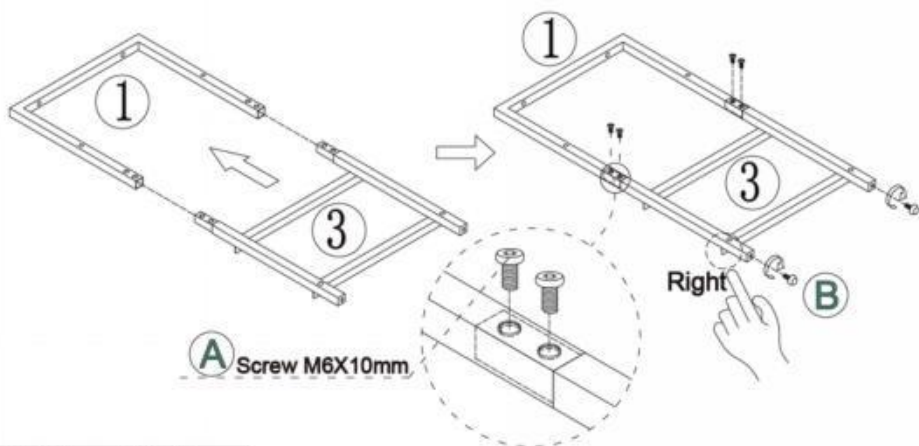

A X4

B X2



3

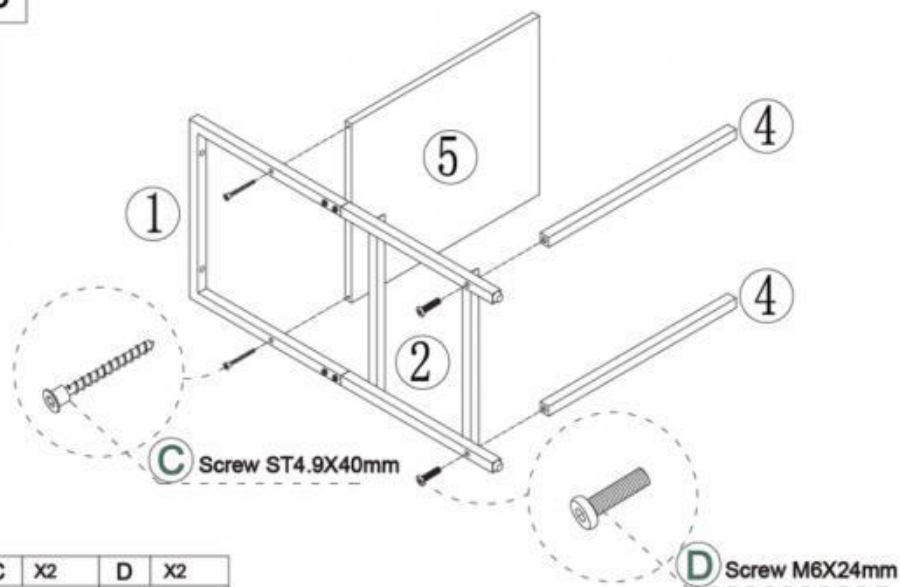

C	X2	D	X2
---	----	---	----

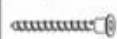

ST4.9X40mm



M6X24mm

4

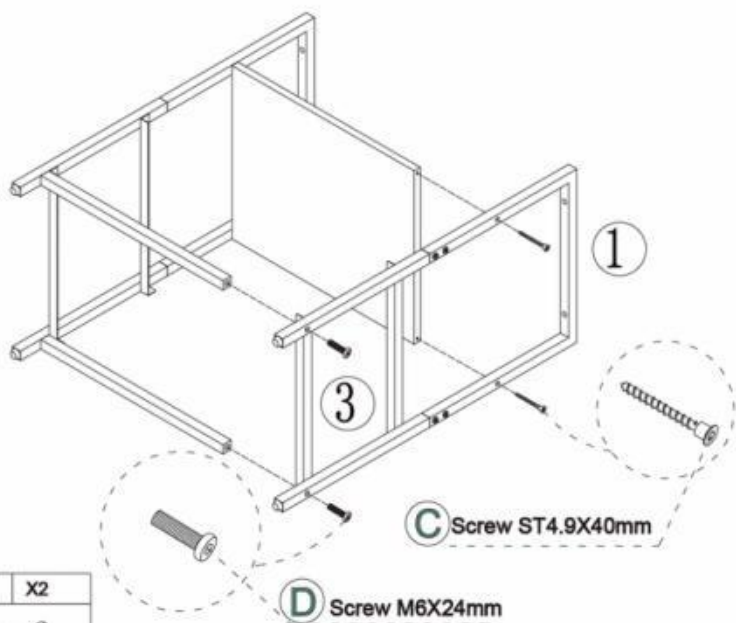

C	X2	D	X2
---	----	---	----

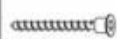





ST4.9X40mm

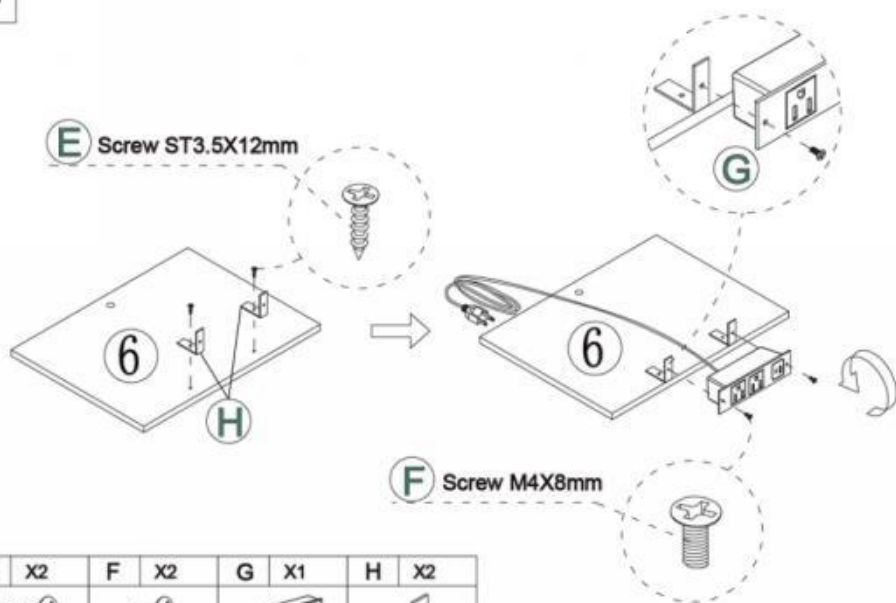

M6X24mm

5



E	X2	F	X2	G	X1	H	X2
							
ST3.5X12mm		M4X8mm					

6

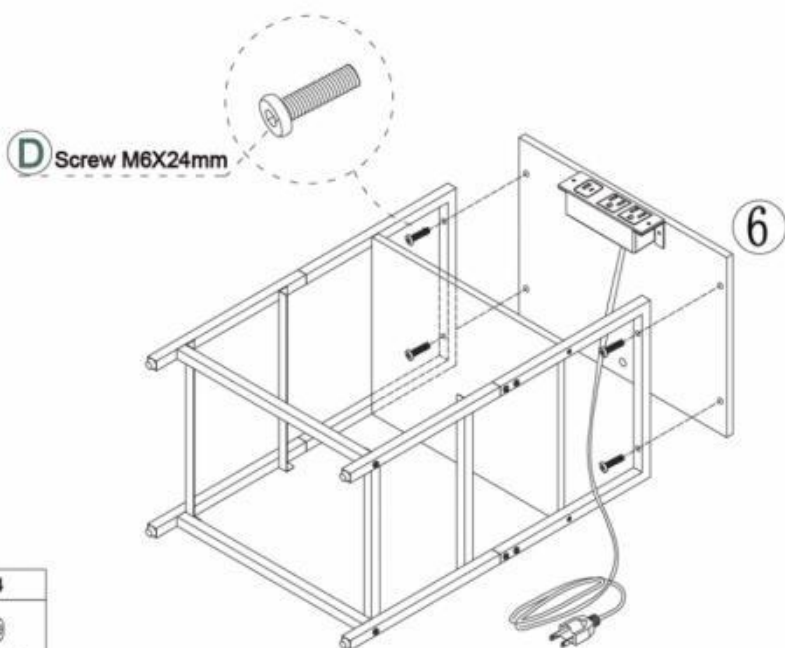

D	X4
	
M6X24mm	

7

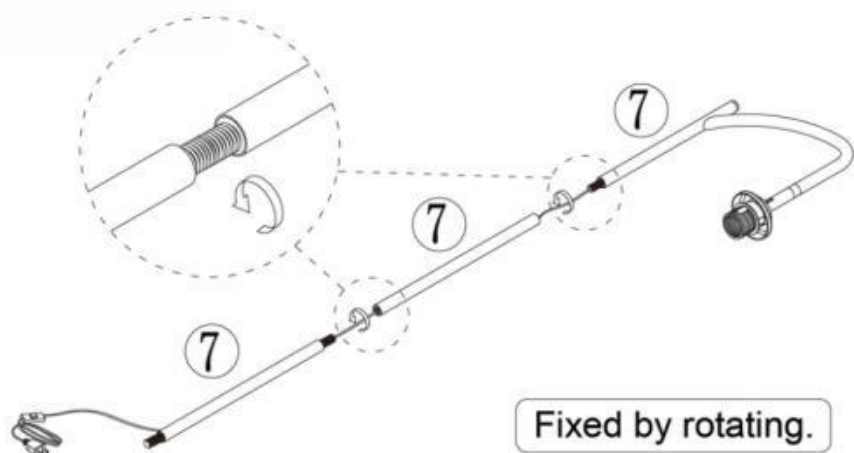

8

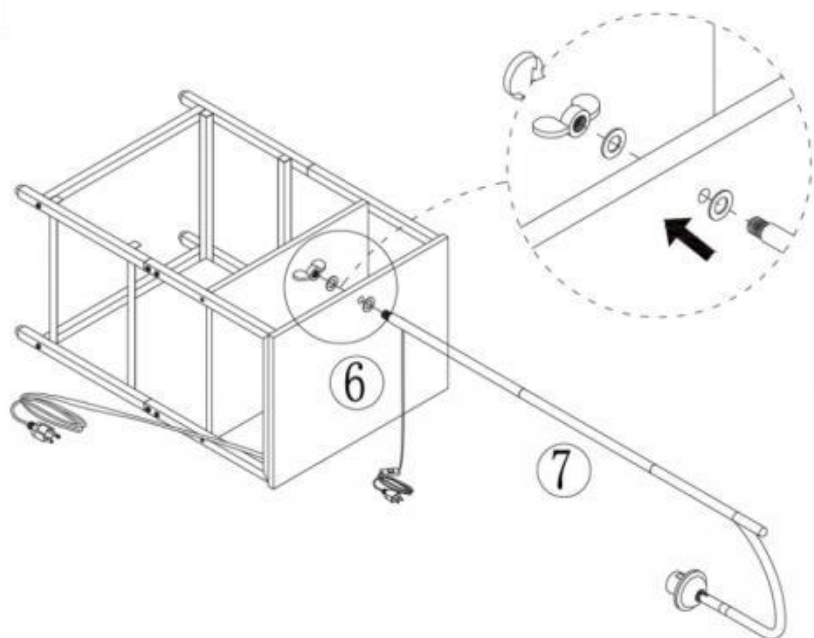

11

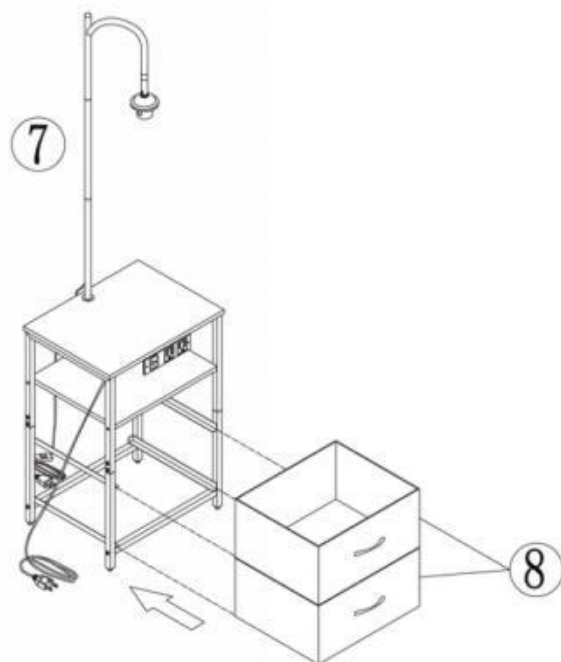

12

Installation prompt:

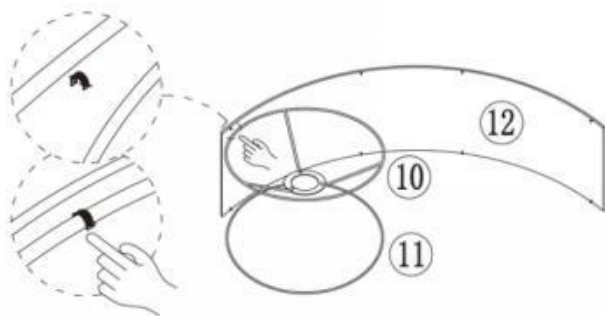

The clips at the top and bottom snap along the iron wire to hold.
The edges of the hin iron sheet are sharp, Be careful to avoid cuts.

13

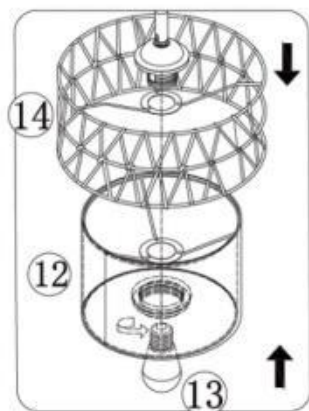
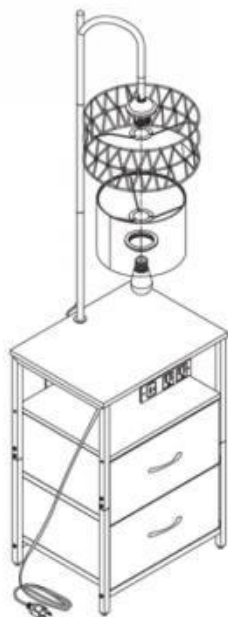

Do not power on during installation

14

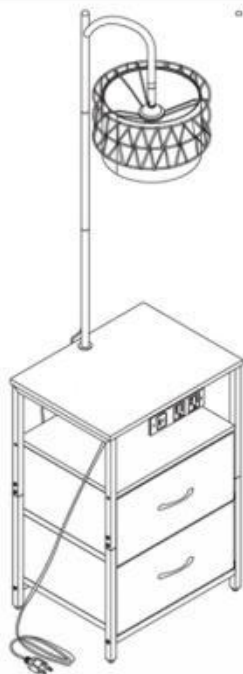

PRODUCT PARAMETER

Modell	ZH636
Hauptfarbe	braun und schwarz
Produkt Größe (T*B*H)	400 x 300 x 1500 mm
Nettogewicht	etwa 5,39 kg

* Produktmerkmale wie Spezifikationen, Aussehen und Design können ohne vorherige Ankündigung geändert werden.

Hersteller: Shanghaimuxinmuyeyouxiangongsi

Adresse: Shuangchenglu 803nong11hao1602A-1609shi, baoshanqu, Shanghai 200000 CN.

Importiert nach Australien: SIHAO PTY LTD. 1 ROKEVA STREET, EASTWOOD NSW 2122, Australien

Importiert in die USA: Sanven Technology Ltd. Suite 250, 9166 Anaheim Place, Rancho Cucamonga, CA 91730

EC	REP
-----------	------------

E-CrossStu GmbH
Mainzer Landstr.69, 60329 Frankfurt am Main.

UK	REP
-----------	------------

YH CONSULTING LIMITED.
C/O YH Consulting Limited Office 147, Centurion House, London Road, Staines-upon-Thames, Surrey, TW18 4AX



VEVOR

Upgrade · The Home Creator Way

TAVOLINO IN METALLO



MANUALE D' USO

MODELLO: ZH636

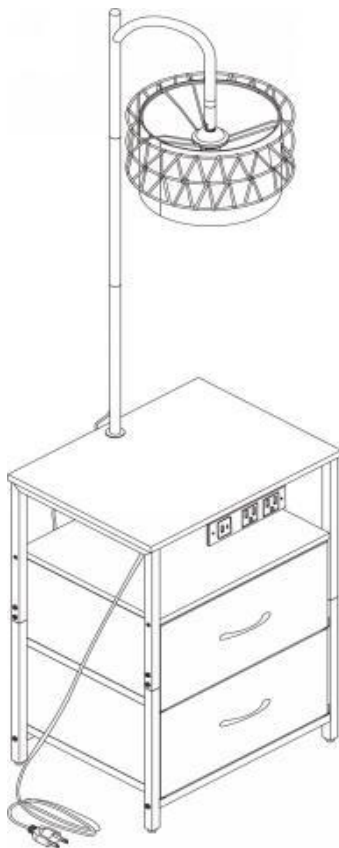
MODELLO: ZH636



Queste sono le istruzioni originali, si prega di leggere attentamente tutte le istruzioni del manuale prima dell'uso. VEVOR si riserva la piena interpretazione del proprio manuale utente. L'aspetto del prodotto dipenderà dal prodotto ricevuto. Vi preghiamo di scusarci se non vi informeremo più in caso di aggiornamenti tecnologici o software sul nostro prodotto.

	Avvertenza: per ridurre il rischio di lesioni, l'utente deve leggere attentamente il manuale di istruzioni.
	Attenzione: solo per uso interno
	<p>Informazioni FCC:</p> <p>ATTENZIONE: Cambiamenti o modifiche non espressamente approvati dalla parte responsabile della conformità potrebbero invalidare l'autorizzazione dell'utente a utilizzare l'apparecchiatura! Questo dispositivo è conforme alla Parte 15 delle Norme FCC. Il funzionamento è soggetto alle seguenti due condizioni:</p> <ol style="list-style-type: none">1) Questo prodotto può causare interferenze dannose.2) Questo prodotto deve accettare qualsiasi interferenza ricevuta, comprese quelle che potrebbero causare un funzionamento indesiderato.

SAFETY INSTRUCTIONS

AVVERTIMENTO:

Leggere attentamente il presente materiale prima di utilizzare il prodotto. La mancata osservanza di questa indicazione può causare gravi lesioni.

Precauzioni di montaggio

37. Montare solo secondo queste istruzioni. Un montaggio improprio può comportare pericoli.
38. Durante il montaggio, indossare occhiali di sicurezza omologati ANSI e guanti da lavoro resistenti.
39. Mantenere l'area di assemblaggio pulita e ben illuminata.
40. Se dopo aver disimballato il prodotto si riscontrano parti difettose e/o mancanti, interrompere immediatamente il montaggio e contattarci.
41. Non montare se si è stanchi o sotto l'effetto di alcol, droghe o medicinali.
42. Le capacità del prodotto si applicano solo ai prodotti correttamente e completamente assemblati.
43. Montare su una superficie piana, livellata, dura e liscia, in grado di sostenere in modo sicuro il tavolino metallico.
44. Se possibile, è possibile utilizzare utensili elettrici per facilitare il montaggio.
45. Si raccomanda che il montaggio venga effettuato da almeno 2 adulti. Leggere attentamente le istruzioni di montaggio prima di procedere e attenersi scrupolosamente a ogni passaggio indicato.
46. Si prega di notare che alcuni tipi di pezzi hanno una scorta.
47. Utilizzare un trapano elettrico per praticare i fori nel muro. Misurare attentamente la distanza tra i due fori e mantenerli a livello.
48. Per ulteriori informazioni sui componenti elencati nelle pagine seguenti, fare riferimento allo schema di montaggio di questo manuale. Disimballare e separare tutti i componenti in un'area di lavoro pulita.

Precauzioni d'uso

31. Non superare i valori specificati capacità di peso.
32. Utilizzare solo su una superficie piana, livellata, dura e liscia in grado di sostenere in sicurezza un tavolino metallico completamente carico .
33. Utilizzare solo come previsto.
34. Ispezionare prima di ogni utilizzo; non utilizzare se alcune parti sono allentate o danneggiate.
35. Questo prodotto deve essere fissato saldamente alla parete per evitare lesioni personali causate da cadute/ribaltamenti.
36. Fissare sempre saldamente l'oggetto alla parete prima dell'uso.
37. Non è destinato all'uso da parte di bambini di età inferiore ai 5 anni. I bambini devono utilizzare il prodotto sotto la supervisione di un adulto.
38. È vietato ai bambini arrampicarsi o giocare sul prodotto per evitare gravi lesioni personali causate dal ribaltamento.
39. Durante il montaggio, tenere le parti di piccole dimensioni fuori dalla portata dei bambini. Potrebbero essere fatali se ingerite o inalate.
- 40.** Per evitare potenziali pericoli di soffocamento, tenere tutti i componenti e l'imballaggio (pellicole, sacchetti di plastica e schiuma, ecc.) lontano dalla portata di neonati e bambini.





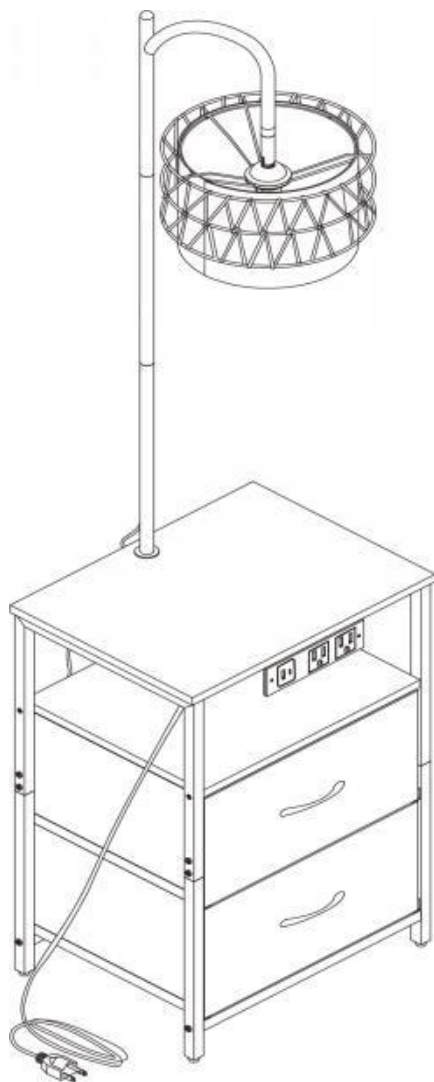

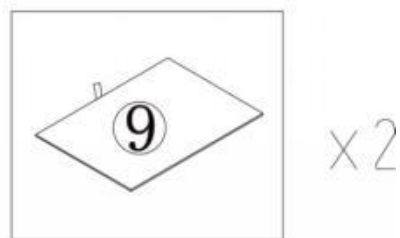
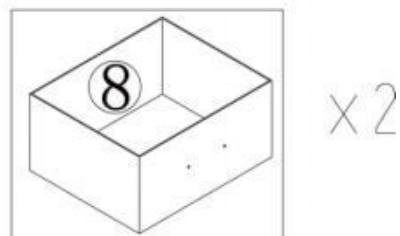
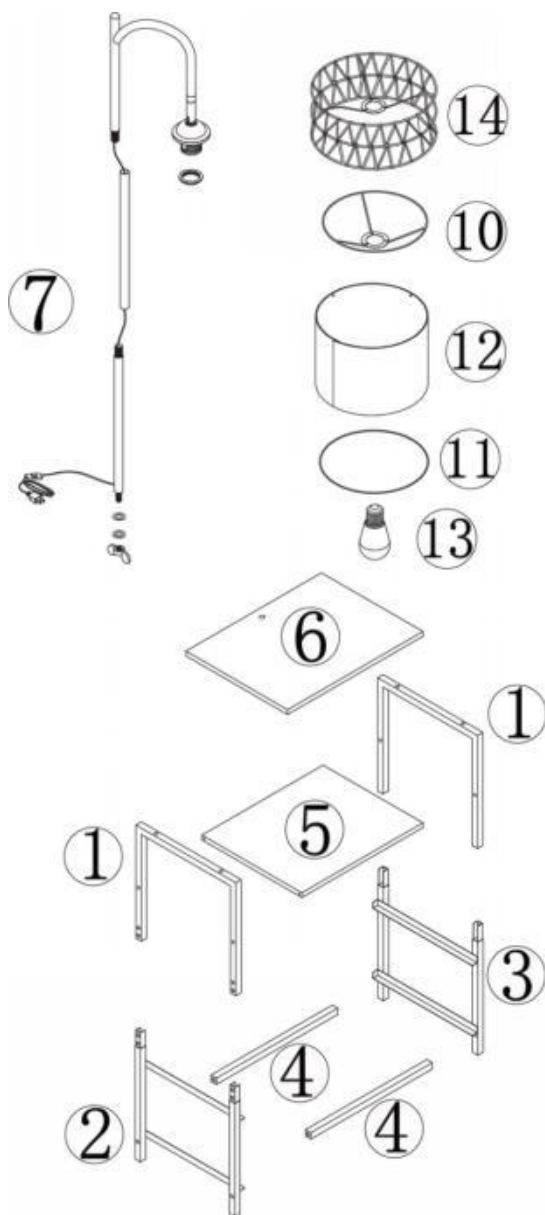

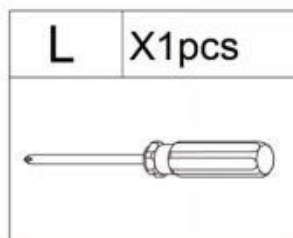
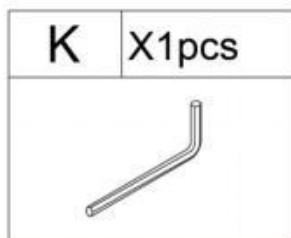
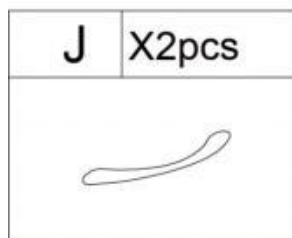
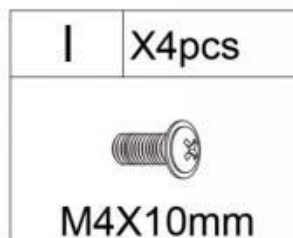
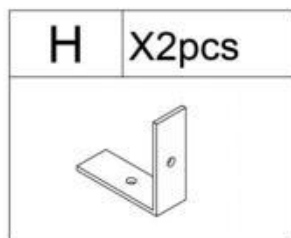
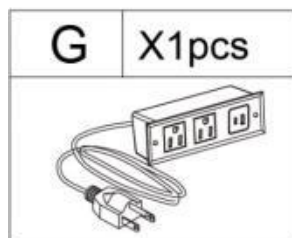
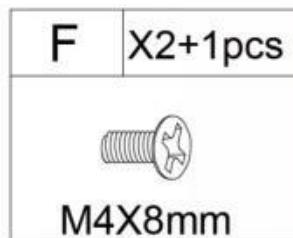
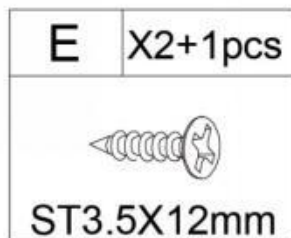
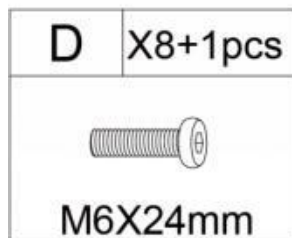
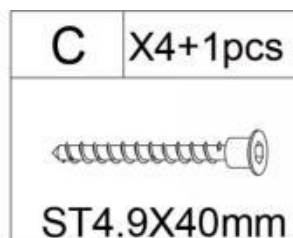
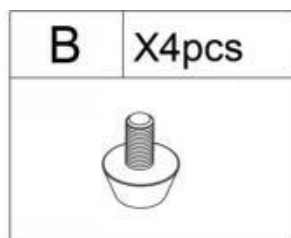
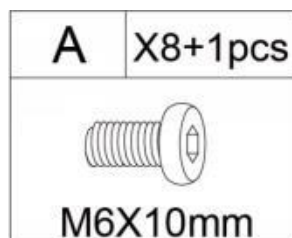

CONSERVARE QUESTO MANUALE

PARTS LIST



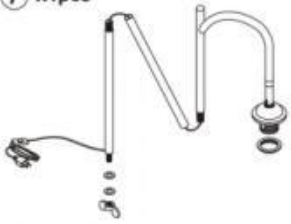
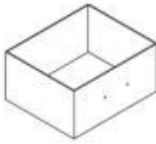
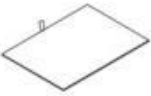

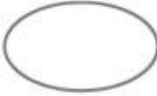

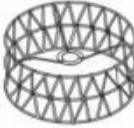
<p>① x2pcs</p> 	<p>② x1pcs</p> 	<p>③ x1pcs</p> 
<p>④ x2pcs</p> 	<p>⑤ x1pcs</p> 	<p>⑥ x1pcs</p> 
<p>⑦ x1pcs</p> 	<p>⑧ x2pcs</p> 	<p>⑨ x2pcs</p> 
<p>⑩ x1pcs</p> 	<p>⑪ x1pcs</p> 	<p>⑫ x1pcs</p> 
<p>⑬ x1pcs</p> 	<p>⑭ x1pcs</p> 	

ASSEMBLY STEP

1

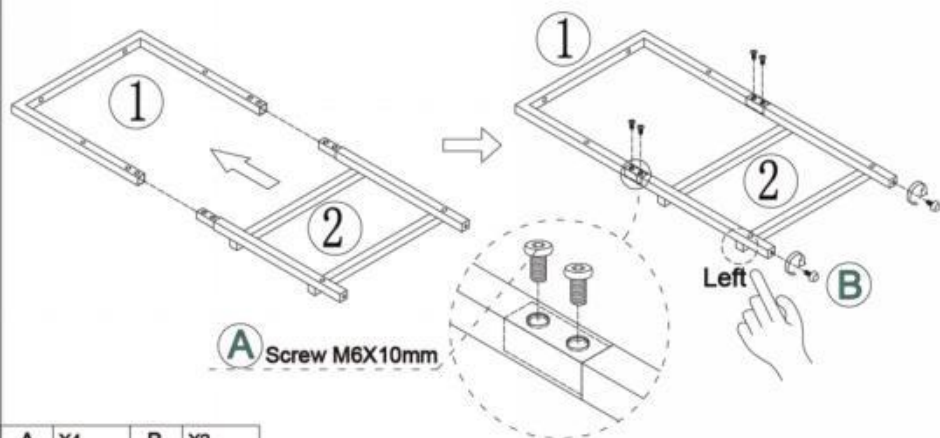

A X4

B X2



2

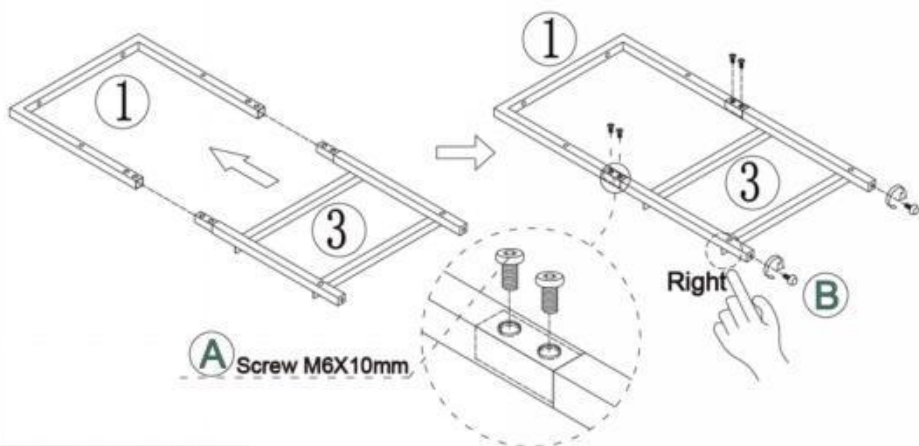

A X4

B X2



3

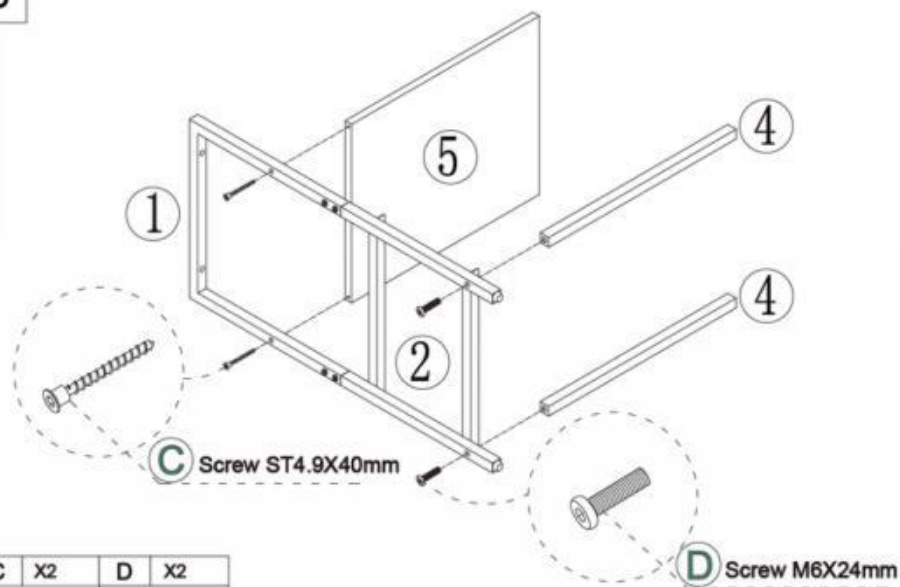

C	X2	D	X2
---	----	---	----

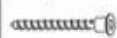

ST4.9X40mm



M6X24mm

4

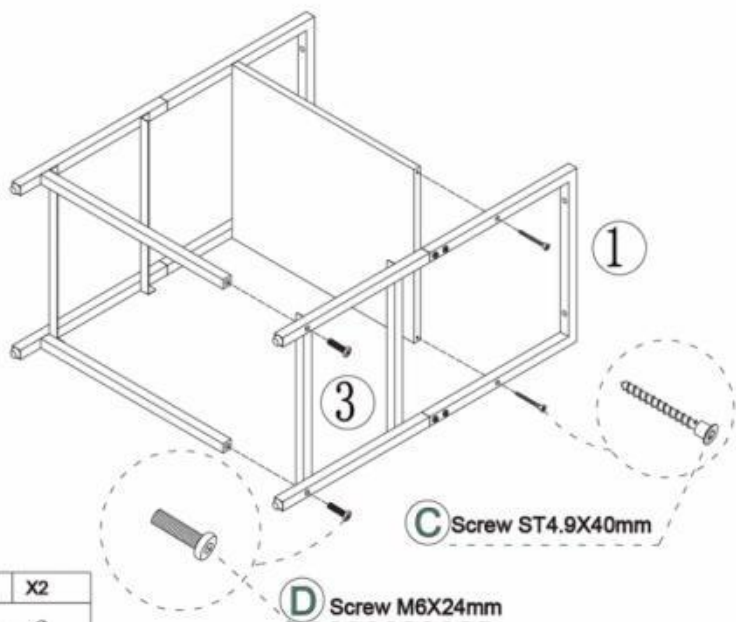

C	X2	D	X2
---	----	---	----

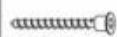





ST4.9X40mm

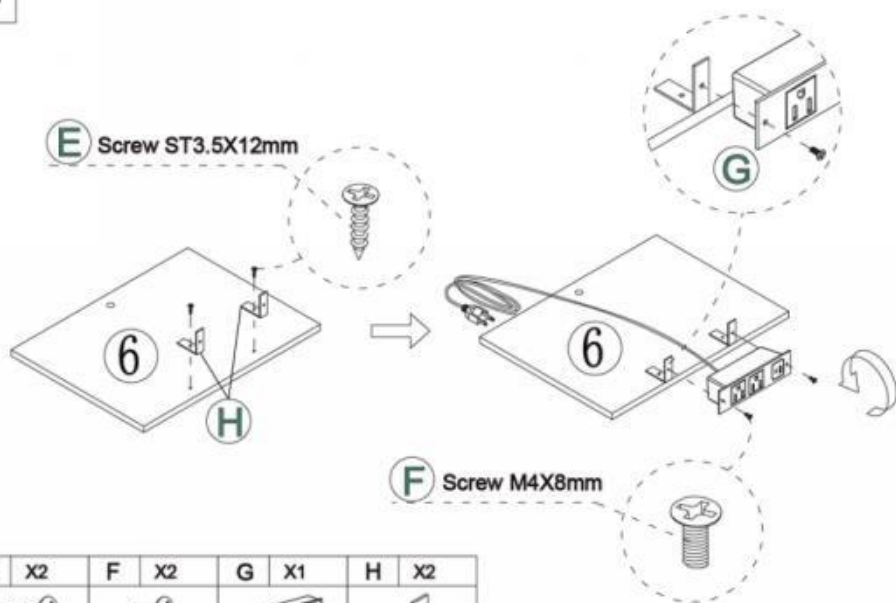

M6X24mm

5



E	X2	F	X2	G	X1	H	X2
							
ST3.5X12mm		M4X8mm					

6

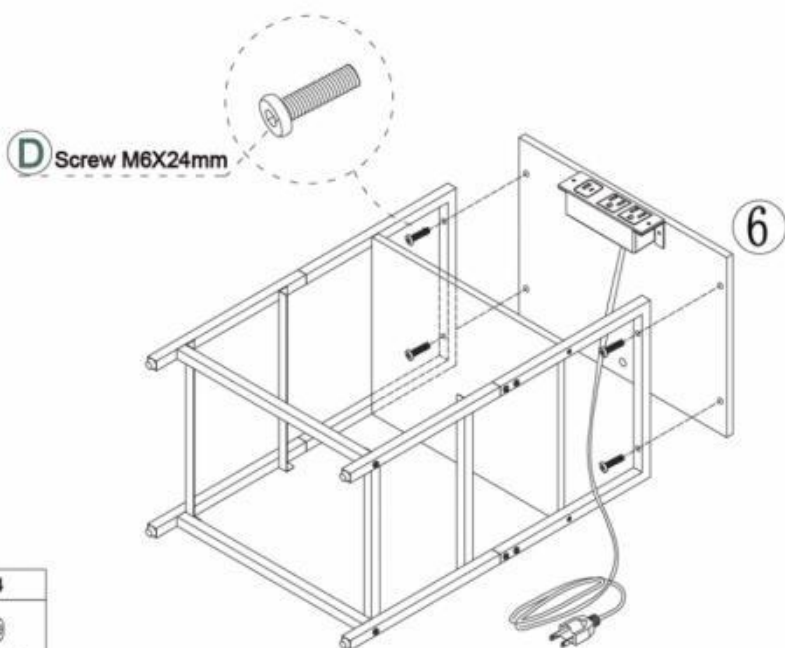

D	X4
	
M6X24mm	

7

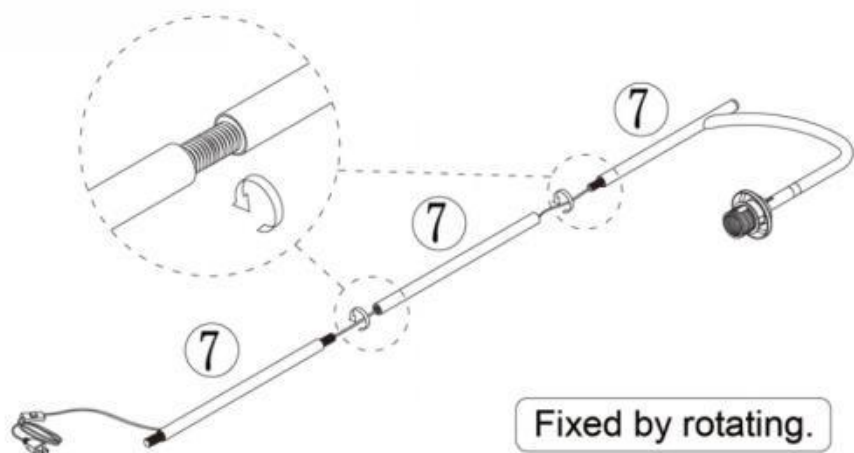

8

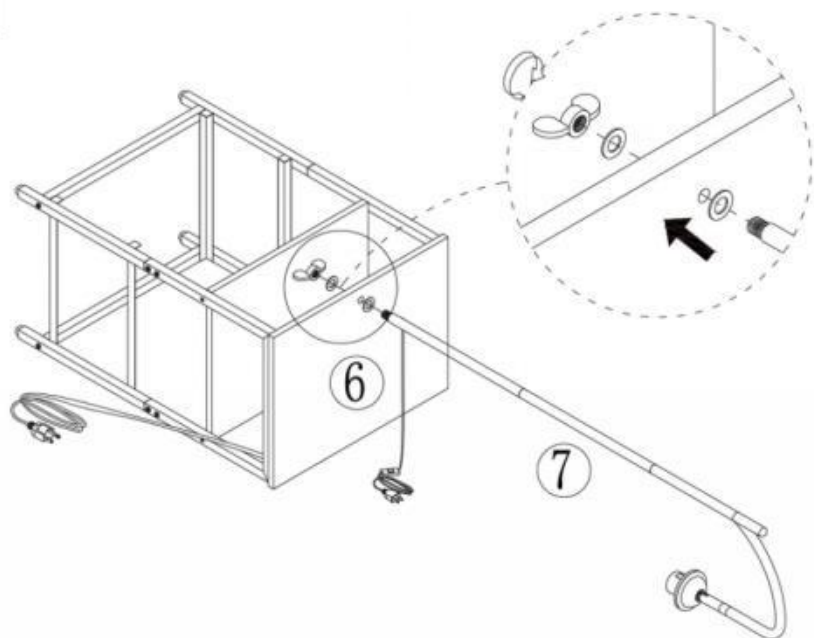

9

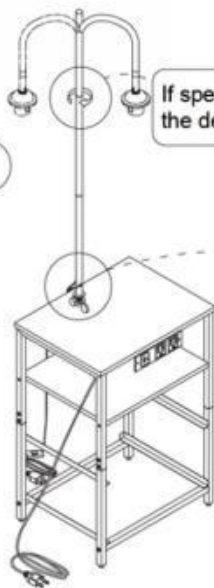

If specific circumstances arise, you can achieve the desired outcome by loosening this joint.

Installation prompt:

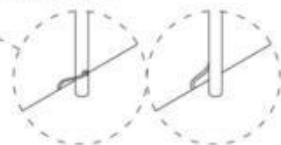

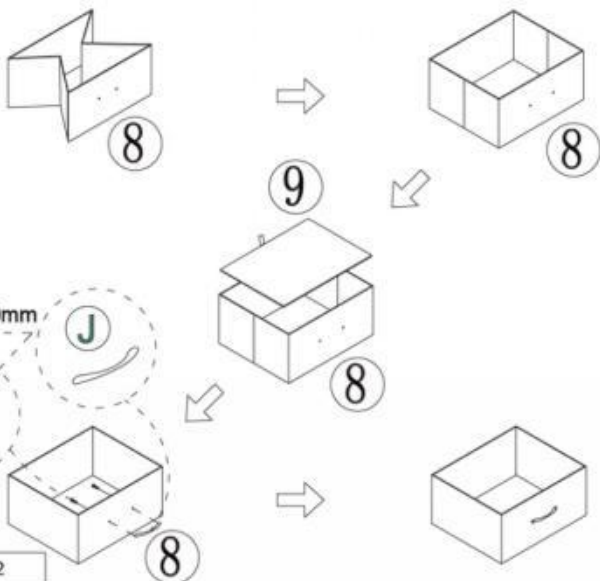

Due to the limitations of the manufacturing process, the position of the cable outlet hole may have deviations. If you have high requirements in this regard, you can wrap the tape around the threaded part in the middle of the lamp post and then try to tighten the lamp post until the outlet hole is completely aligned.

10



I Screw M4X10mm

J

I	X4	J	X2
			
M4X10mm			

X2

11

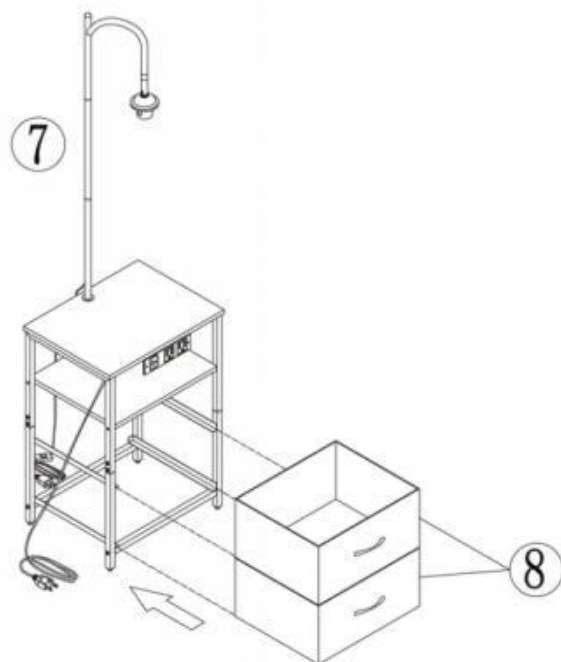

12

Installation prompt:

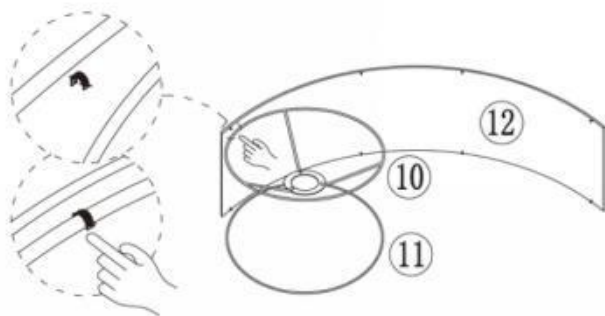

The clips at the top and bottom snap along the iron wire to hold.
The edges of the hin iron sheet are sharp, Be careful to avoid cuts.

13

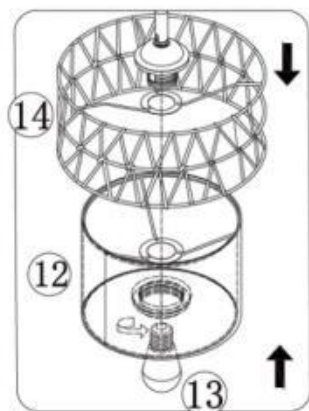
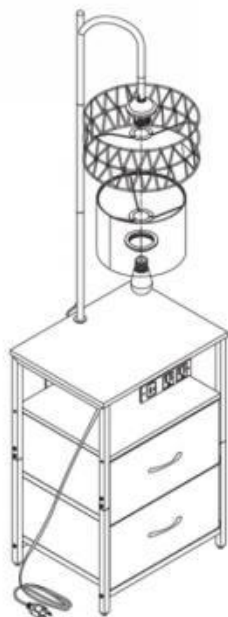

Do not power on during installation

14

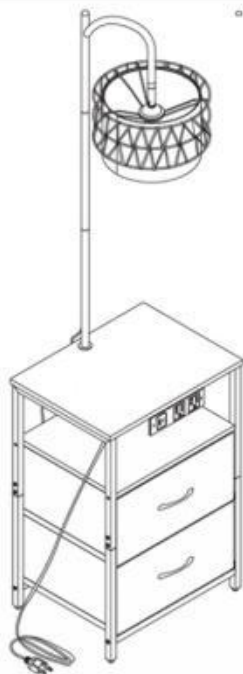

PRODUCT PARAMETER

Modello	ZH636
Colore principale	marrone e nero
Prodotto Misurare (P*L*A)	400*300*1500mm
Peso netto	Circa 5,39 kg

* Le specifiche, l'aspetto e il design dei prodotti sono soggetti a modifiche senza preavviso.

Produttore: Shanghai muxinmuyeyouxiangongsi

Indirizzo: Shuangchenglu 803nong11hao1602A-1609shi, baoshanqu, shanghai 200000 CN.

Importato in AUS: SIHAO PTY LTD. 1 ROKEVA STREET EASTWOOD NSW 2122 Australia

Importato negli USA: Sanven Technology Ltd. Suite 250, 9166 Anaheim Place, Rancho Cucamonga, CA 91730

EC	REP
-----------	------------

E-CrossStu GmbH
Mainzer Landstr.69, 60329 Frankfurt am Main.

UK	REP
-----------	------------

YH CONSULTING LIMITED.
C/O YH Consulting Limited Office 147, Centurion House, London Road, Staines-upon-Thames, Surrey, TW18 4AX



VEVOR

Upgrade · The Home Creator Way

MESA AUXILIAR DE METAL



MANUAL DEL USUARIO

MODELO: ZH636

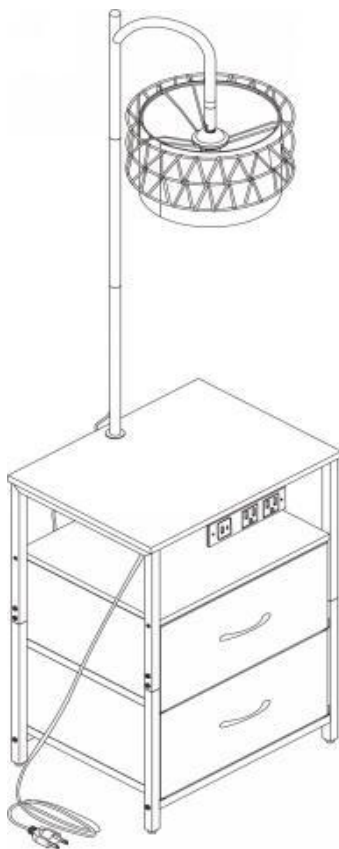
MODELO: ZH636



Estas son las instrucciones originales; lea atentamente todas las instrucciones del manual antes de utilizarlo. VEVOR se reserva el derecho de interpretar este manual de usuario. La apariencia del producto dependerá del producto que haya recibido. Le rogamos que nos disculpe si no le informamos de nuevo si hay actualizaciones tecnológicas o de software en nuestro producto.

	Advertencia: Para reducir el riesgo de lesiones, el usuario debe leer atentamente el manual de instrucciones.
	Advertencia: solo para uso en interiores
	<p>Información de la FCC:</p> <p>PRECAUCIÓN: ¡Los cambios o modificaciones no aprobados expresamente por la parte responsable del cumplimiento podrían anular la autoridad del usuario para operar el equipo!</p> <p>Este dispositivo cumple con la Parte 15 de las Normas de la FCC. Su funcionamiento está sujeto a las dos condiciones siguientes:</p> <ol style="list-style-type: none">1) Este producto puede causar interferencias dañinas.2) Este producto debe aceptar cualquier interferencia recibida, incluida aquella que pueda provocar un funcionamiento no deseado.

SAFETY INSTRUCTIONS

ADVERTENCIA:

Lea este material antes de usar este producto. De lo contrario, podría sufrir lesiones graves.

Precauciones de montaje

49. Ensamble únicamente según estas instrucciones. Un montaje incorrecto puede causar peligros.
50. Use gafas de seguridad aprobadas por ANSI y guantes de trabajo resistentes durante el montaje.
51. Mantenga el área de reunión limpia y bien iluminada.
52. Si hay piezas defectuosas o faltantes después de desembalar, detenga el montaje inmediatamente y póngase en contacto con nosotros.
53. No se reúna si está cansado o bajo la influencia del alcohol, drogas o medicamentos.
54. Las capacidades del producto se aplican únicamente a productos ensamblados de forma correcta y completa.
55. Ensamble sobre una superficie plana, nivelada, dura y lisa capaz de soportar de manera segura la mesa auxiliar de metal.
56. Si es posible, puedes utilizar herramientas eléctricas para facilitar el montaje.
57. Se recomienda que el montaje lo realicen al menos dos adultos. Lea las instrucciones de montaje antes de montar y siga estrictamente cada paso.
58. Tenga en cuenta que algunos tipos de piezas tienen repuesto.
59. Utilice un taladro eléctrico para hacer agujeros en la pared. Mida cuidadosamente la distancia entre los dos agujeros y manténgalos nivelados.
60. Para obtener más información sobre las piezas que se enumeran en las siguientes páginas, consulte el diagrama de montaje de este manual. Desembale y separe todas las piezas en un área de trabajo limpia.

Tome precauciones

41. No exceda lo especificado capacidades de peso.
42. Úselo únicamente sobre una superficie plana, nivelada, dura y lisa que pueda soportar de forma segura una mesa auxiliar de metal completamente cargada .
43. Úselo únicamente según lo previsto.
44. Inspeccione antes de cada uso; no lo utilice si las piezas están sueltas o dañadas.
45. Este producto debe fijarse firmemente a la pared para evitar lesiones personales causadas por caídas o inclinaciones.
46. Fije siempre de forma segura el artículo a la pared antes de utilizarlo.
47. No está destinado a ser utilizado por niños menores de 5 años. Los niños deben estar bajo la supervisión de un adulto para utilizar el producto.
48. Está prohibido que los niños se suban o jueguen sobre el producto para evitar lesiones corporales graves si se cae.
49. Durante el montaje, mantenga las piezas pequeñas fuera del alcance de los niños. Podrían ser mortales si se ingieren o inhalan.
- 50.** Para evitar posibles peligros de asfixia, mantenga todas las piezas y el embalaje (películas, bolsas de plástico y espuma, etc.) fuera del alcance de bebés y niños.





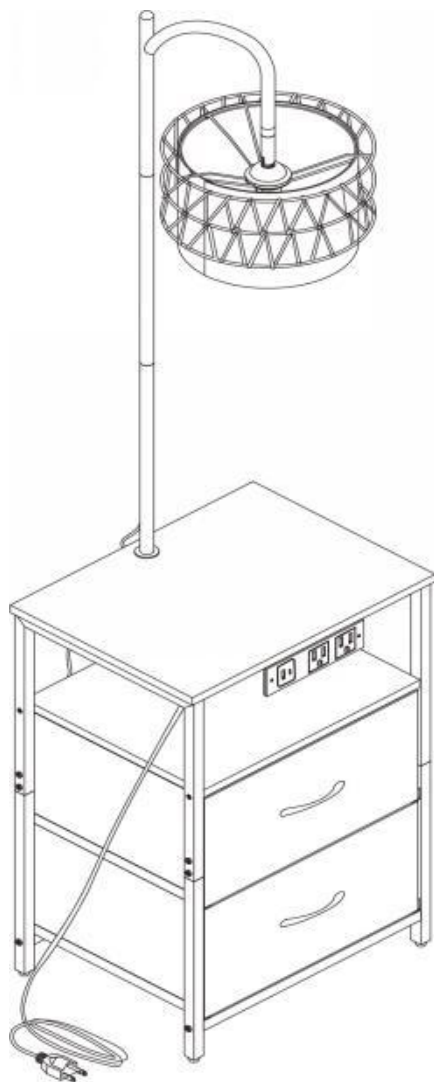

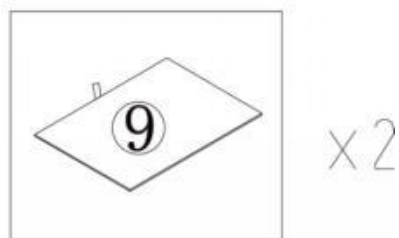
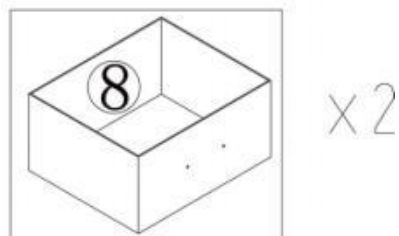
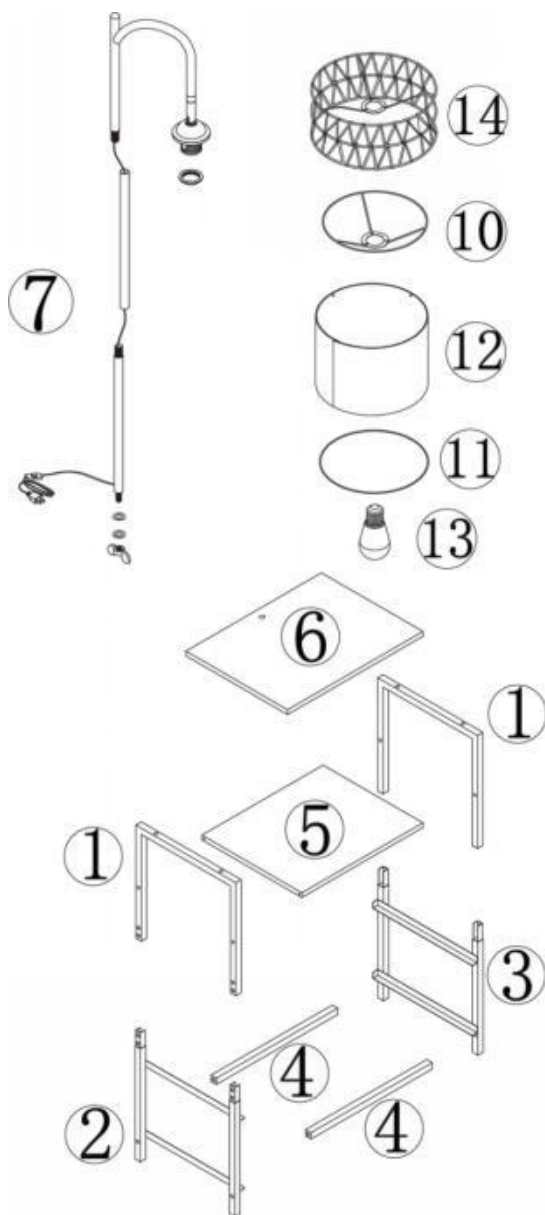

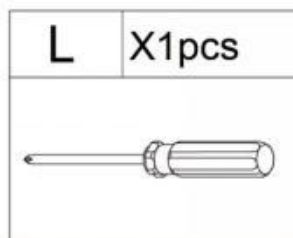
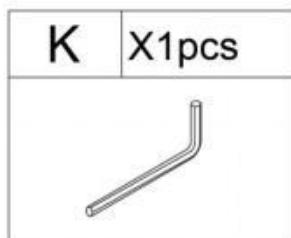
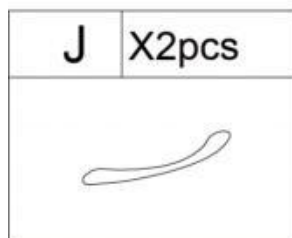
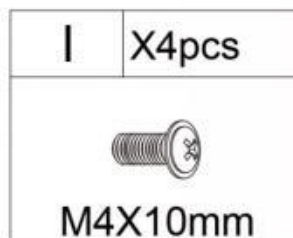
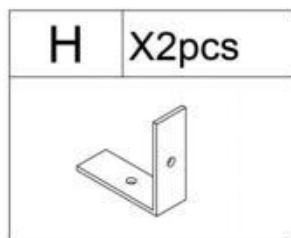
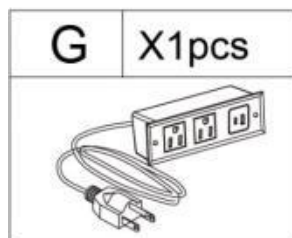
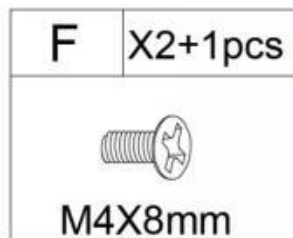
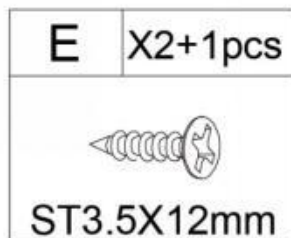
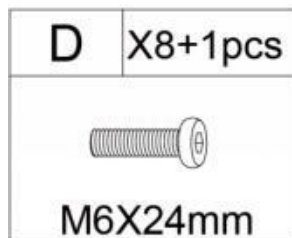
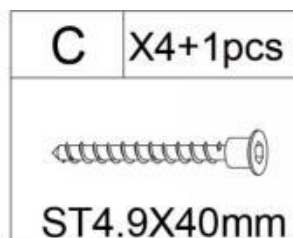
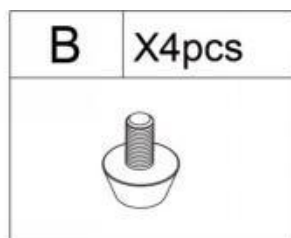
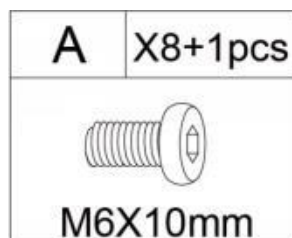

GUARDE ESTE MANUAL

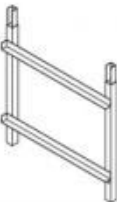
PARTS LIST



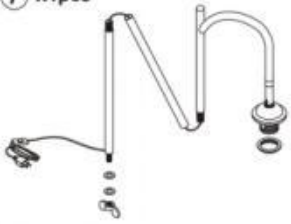
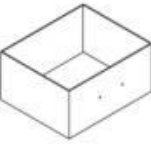
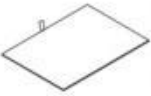

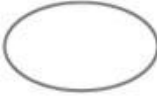

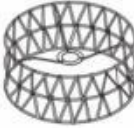
<p>① x2pcs</p> 	<p>② x1pcs</p> 	<p>③ x1pcs</p> 
<p>④ x2pcs</p> 	<p>⑤ x1pcs</p> 	<p>⑥ x1pcs</p> 
<p>⑦ x1pcs</p> 	<p>⑧ x2pcs</p> 	<p>⑨ x2pcs</p> 
<p>⑩ x1pcs</p> 	<p>⑪ x1pcs</p> 	<p>⑫ x1pcs</p> 
<p>⑬ x1pcs</p> 	<p>⑭ x1pcs</p> 	

ASSEMBLY STEP

1

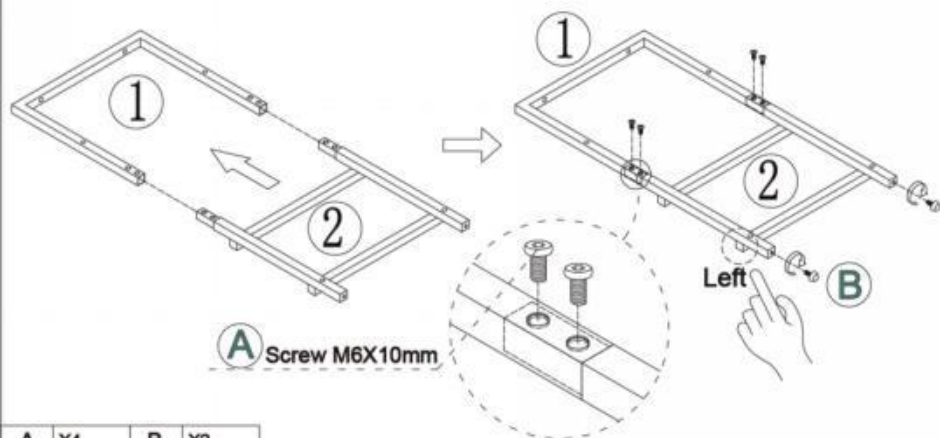

A X4

B X2



2

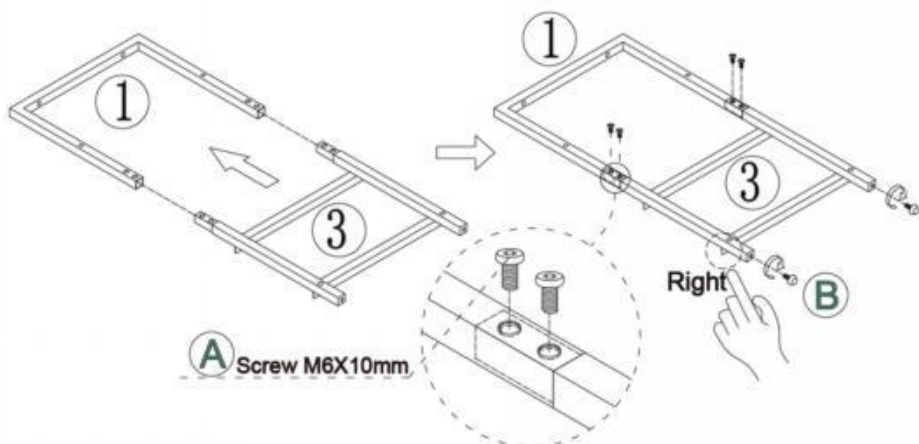

A X4

B X2



3

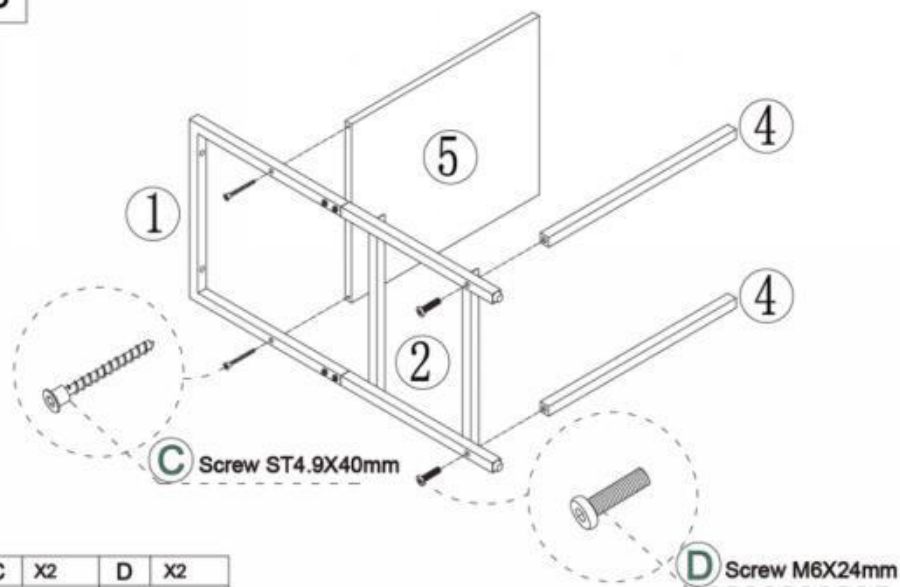

C	X2	D	X2
---	----	---	----



4

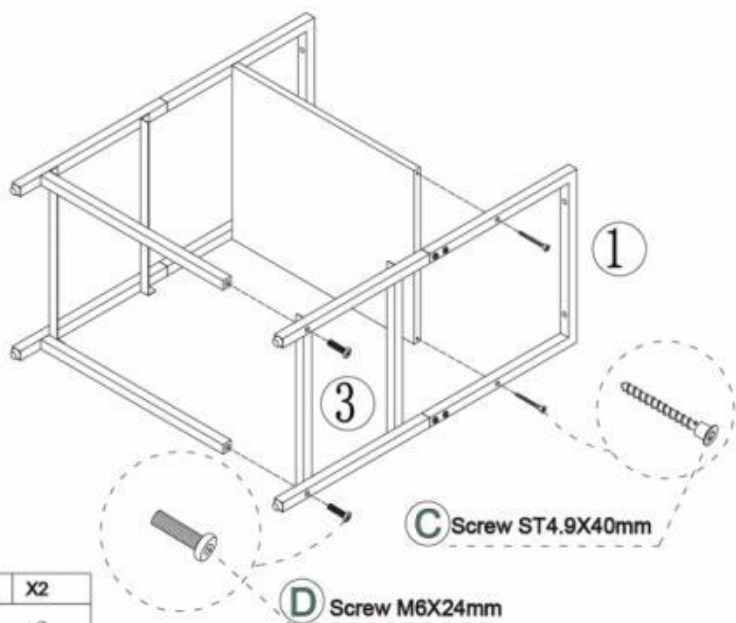





C	X2	D	X2
---	----	---	----

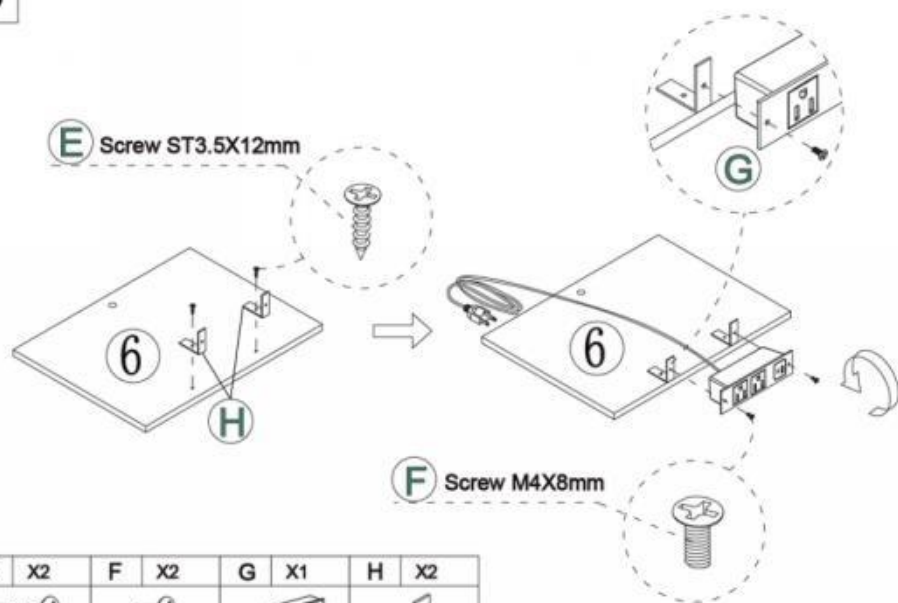

5



E	X2	F	X2	G	X1	H	X2
							
ST3.5X12mm		M4X8mm					

6

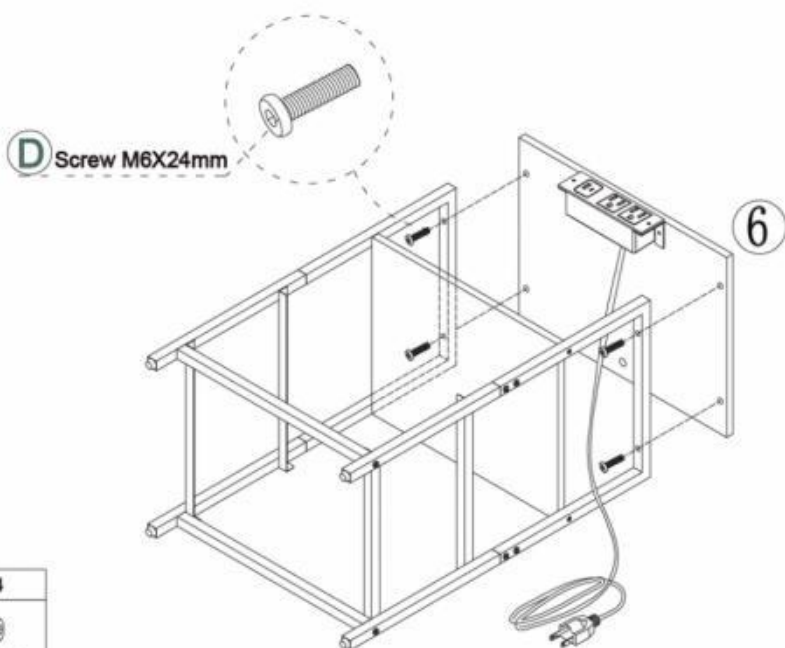

D X4



M6X24mm

7

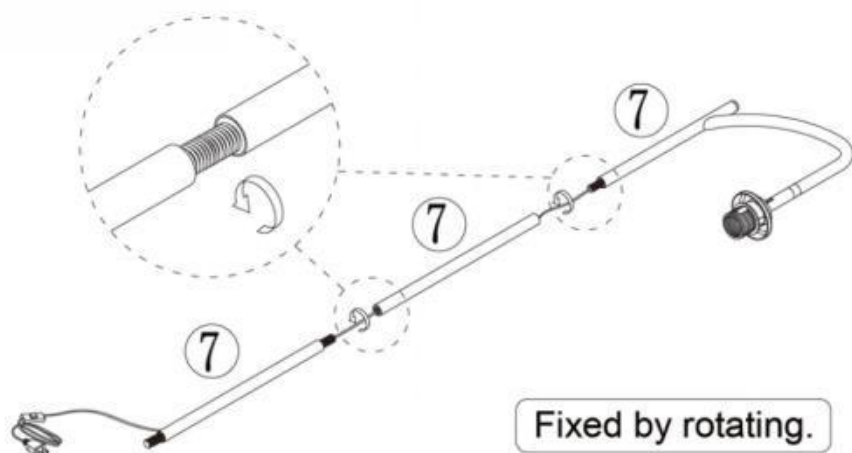

8

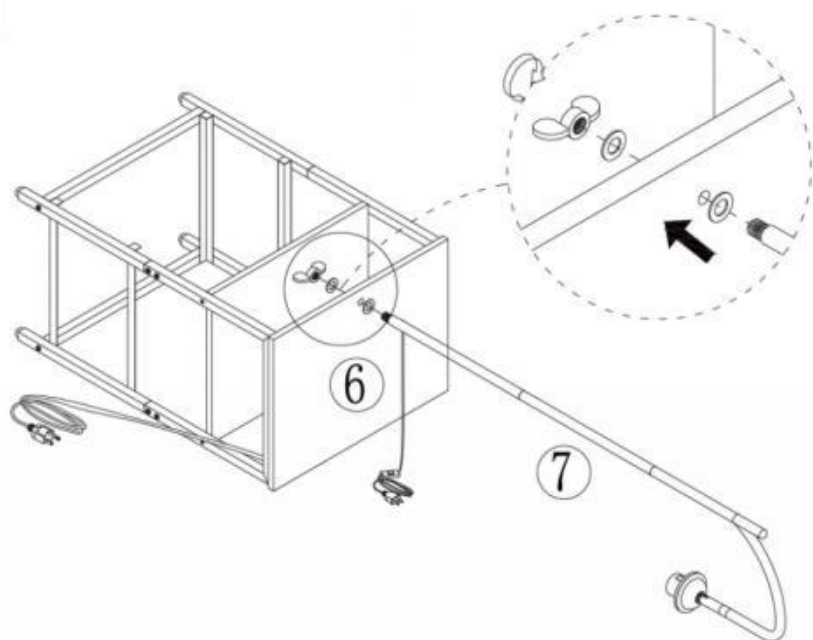

9

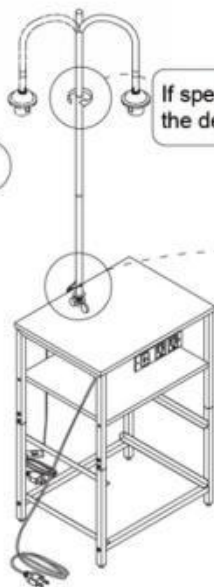

If specific circumstances arise, you can achieve the desired outcome by loosening this joint.

Installation prompt:

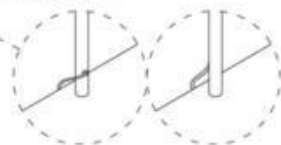

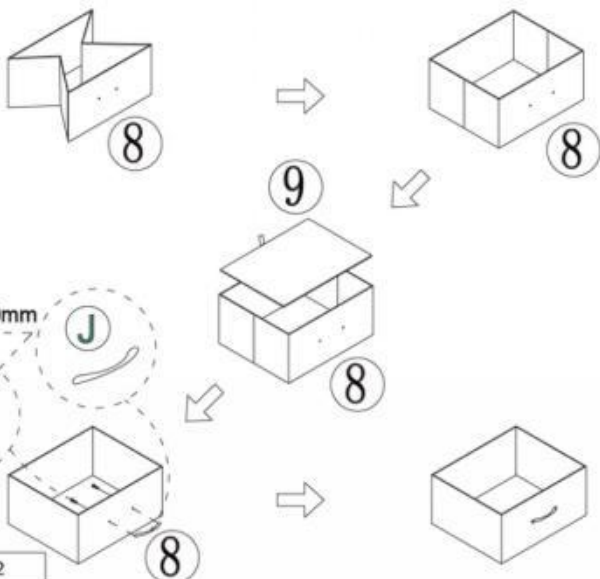

Due to the limitations of the manufacturing process, the position of the cable outlet hole may have deviations. If you have high requirements in this regard, you can wrap the tape around the threaded part in the middle of the lamp post and then try to tighten the lamp post until the outlet hole is completely aligned.

10



I Screw M4X10mm

J

I	X4	J	X2
			
M4X10mm			

X2

11

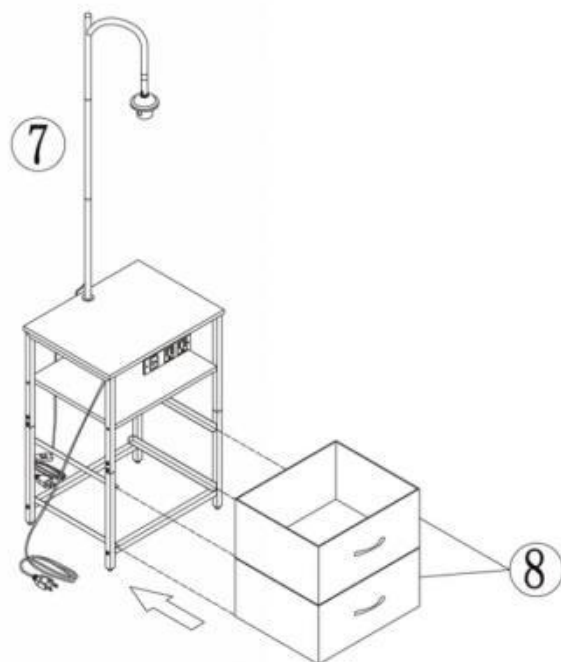

12

Installation prompt:

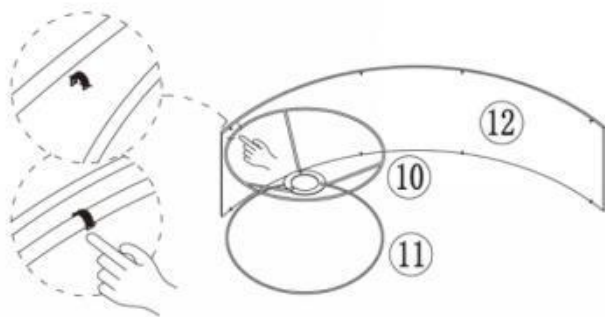

The clips at the top and bottom snap along the iron wire to hold.
The edges of the hin iron sheet are sharp, Be careful to avoid cuts.

13

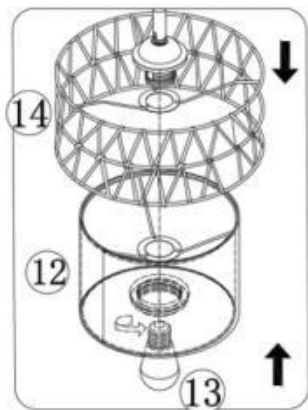
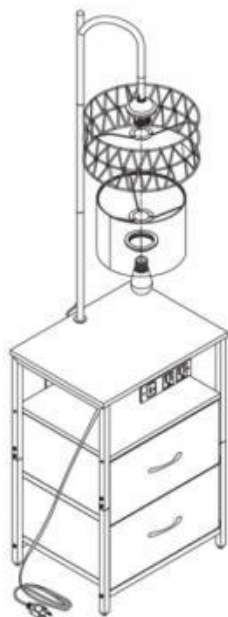

Do not power on during installation

14



PRODUCT PARAMETER

Modelo	ZH636
Color principal	marrón y negro
Producto Tamaño (Profundidad* Ancho*Alto)	400*300*1500 mm
Peso neto	Aproximadamente 5,39 kg

* Los productos como las especificaciones, la apariencia y el diseño están sujetos a modificaciones sin previo aviso.

Fabricante: Shanghaimuxinmuyeyouxiangongsi

Dirección: Shuangchenglu 803nong11hao1602A-1609shi, baoshanqu, shanghai 200000 CN.

Importado a AUS: SIHAO PTY LTD. 1 ROKEVA STREET, EASTWOOD, NSW 2122, Australia

Importado a EE. UU.: Sanven Technology Ltd. Suite 250, 9166 Anaheim Place, Rancho Cucamonga, CA 91730

EC	REP
-----------	------------

E-CrossStu GmbH
Mainzer Landstr.69, 60329 Frankfurt am Main.

UK	REP
-----------	------------

YH CONSULTING LIMITED.
C/O YH Consulting Limited Office 147, Centurion House, London Road, Staines-upon-Thames, Surrey, TW18 1AX



VEVOR

Upgrade · The Home Creator Way

METALOWY STOLIK BOCZNY



INSTRUKCJA OBSŁUGI

MODEL: ZH636

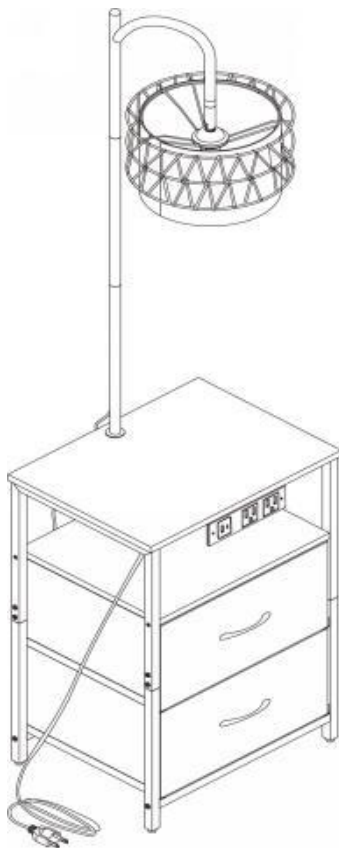
MODEL: ZH636



To jest oryginalna instrukcja obsługi. Przed użyciem prosimy o dokładne zapoznanie się z treścią instrukcji. Firma VEVOR zastrzega sobie prawo do jednoznacznej interpretacji niniejszej instrukcji obsługi. Wygląd produktu zależy od stanu, w jakim go otrzymali Państwo. Prosimy o wyrozumiałość, ale nie będziemy Państwa ponownie informować o aktualizacjach technologicznych lub oprogramowania naszego produktu.

	<p>Ostrzeżenie: Aby zminimalizować ryzyko obrażeń, użytkownik powinien uważnie przeczytać instrukcję obsługi.</p>
	<p>Ostrzeżenie – wyłącznie do użytku wewnątrz pomieszczeń</p>
	<p>Informacje FCC: UWAGA: Zmiany lub modyfikacje, na które nie wyraziła wyraźnej zgody strona odpowiedzialna za zgodność, mogą spowodować unieważnienie prawa użytkownika do korzystania ze sprzętu! To urządzenie jest zgodne z częścią 15 przepisów FCC. Jego eksploatacja podlega dwóm następującym warunkom: 1) Ten produkt może powodować szkodliwe zakłócenia. 2) Produkt ten musi być odporny na wszelkie zakłócenia, w tym zakłócenia mogące powodować niepożądane działanie.</p>

SAFETY INSTRUCTIONS

OSTRZEŻENIE:

Przeczytaj ten materiał przed użyciem produktu. Nieprzestrzeganie tego zalecenia może spowodować poważne obrażenia.

Środki ostrożności podczas montażu

61. Montaż należy wykonywać wyłącznie zgodnie z niniejszą instrukcją. Nieprawidłowy montaż może stwarzać zagrożenie.
62. Podczas montażu należy nosić okulary ochronne zatwierdzone przez ANSI oraz wytrzymałe rękawice robocze.
63. Utrzymuj miejsce zgromadzenia w czystości i dobrym oświetleniu.
64. Jeżeli po rozpakowaniu okaże się, że część/części są uszkodzone i/lub brakuje ich, prosimy natychmiast zaprzestać montażu i skontaktować się z nami.
65. Nie przychodź na zgromadzenie, jeśli jesteś zmęczony lub pod wpływem alkoholu, narkotyków lub leków.
66. Możliwości produktu odnoszą się wyłącznie do produktów prawidłowo i całkowicie zmontowanych.
67. Zmontuj na płaskiej, równej, twardej i gładkiej powierzchni, która będzie w stanie bezpiecznie utrzymać metalowy stolik.
68. Jeżeli to możliwe, możesz użyć elektronarzędzi, aby ułatwić sobie montaż.
69. Zaleca się, aby montaż wykonały co najmniej dwie osoby dorosłe. Przed montażem należy przeczytać instrukcję montażu i ściśle przestrzegać wszystkich opisanych kroków.
70. Należy pamiętać, że niektóre rodzaje części mają część zapasową.
71. Użyj wiertarki elektrycznej do wybicia otworów w ścianie. Dokładnie zmierz odległość między otworami i utrzymuj je w poziomie.
72. Aby uzyskać dodatkowe informacje dotyczące części wymienionych na kolejnych stronach, zapoznaj się ze schematem montażu w niniejszej instrukcji. Rozpakuj i oddziel wszystkie części w czystym miejscu pracy.

Zachowaj środki ostrożności

51. Nie przekraczać określonej wartości nośności.
52. Stosować wyłącznie na płaskiej, równej, twardej i gładkiej powierzchni, która może bezpiecznie utrzymać w pełni załadowany metalowy stolik.
53. Stosować wyłącznie zgodnie z przeznaczeniem.
54. Przed każdym użyciem należy przeprowadzić kontrolę. Nie używać produktu, jeśli części są luźne lub uszkodzone.
55. Ten produkt musi być solidnie przymocowany do ściany, aby zapobiec obrażeniom ciała spowodowanym upadkiem lub przechyleniem się.
56. Przed użyciem należy zawsze solidnie przymocować przedmiot do ściany.
57. Produkt nie jest przeznaczony do użytku przez dzieci poniżej 5 roku życia. Dzieci muszą korzystać z produktu pod nadzorem osoby dorosłej.
58. Dzieciom zabrania się wspinania się na produkt lub zabawy na nim, aby uniknąć poważnych obrażeń ciała na skutek jego przewrócenia.
59. Podczas montażu należy trzymać drobne części poza zasięgiem dzieci. Połknięcie lub wdychanie może być śmiertelne.
- 60.** Aby uniknąć potencjalnego niebezpieczeństwa uduszenia, wszystkie części i opakowania (folie, plastikowe torby, piankę itp.) należy trzymać z dala od dzieci i niemowląt.





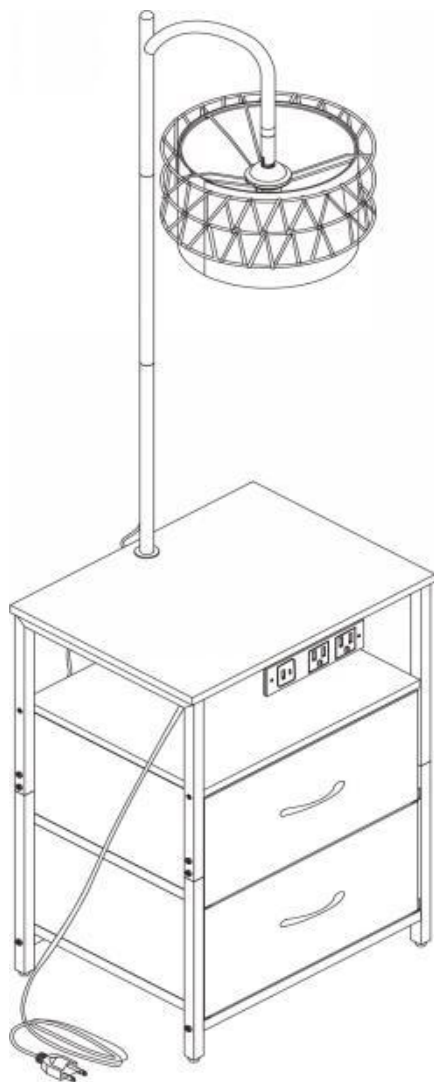

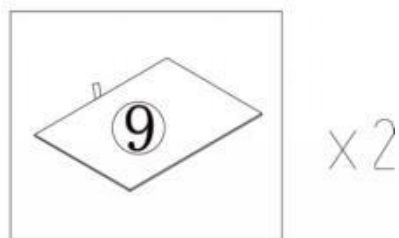
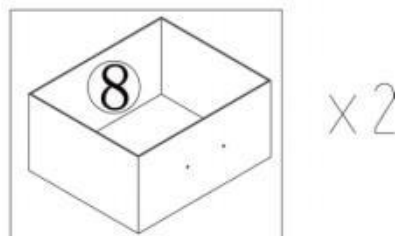
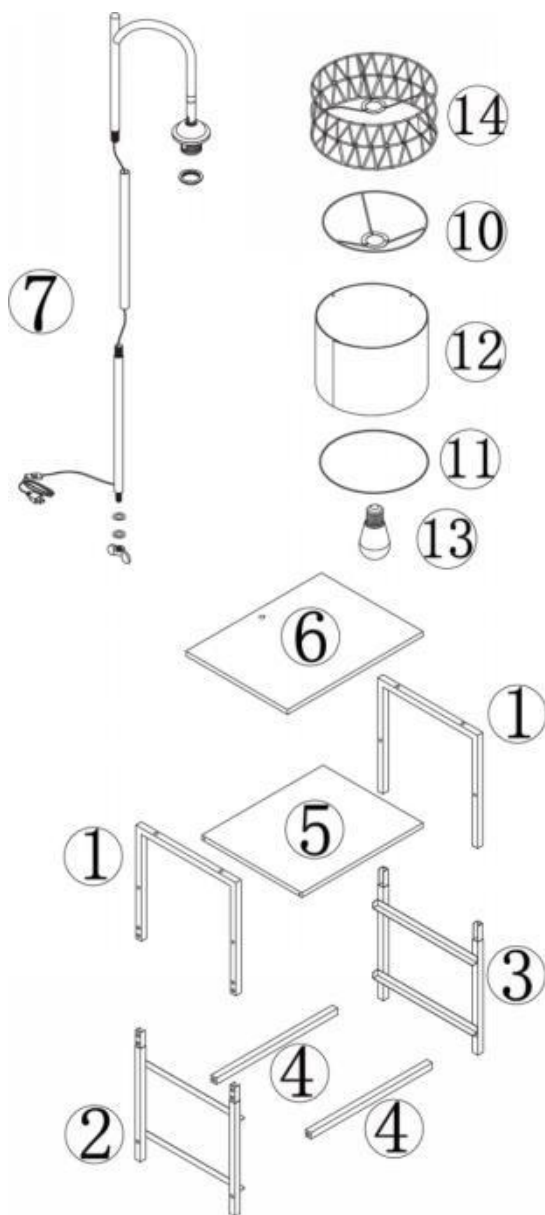

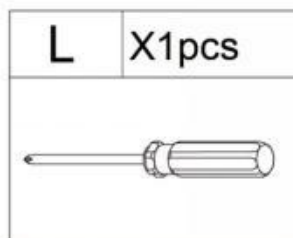
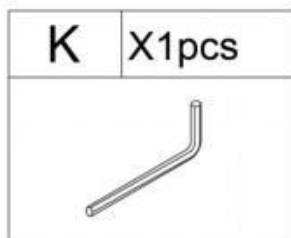
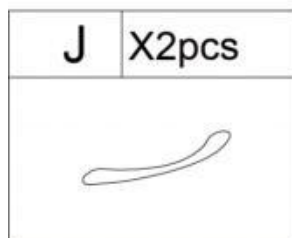
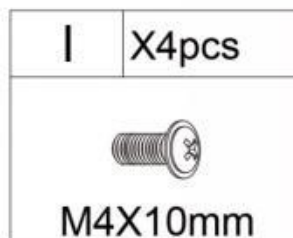
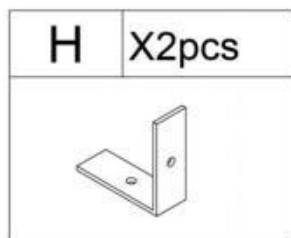
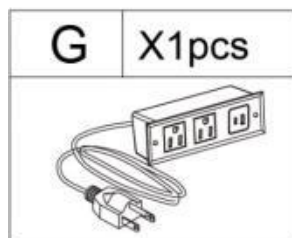
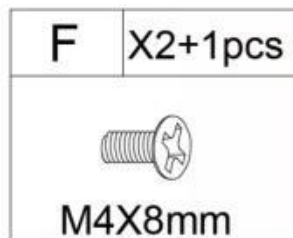
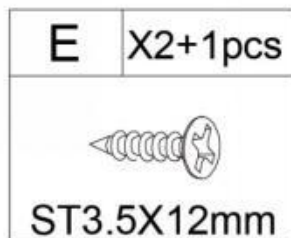
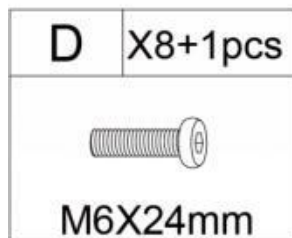
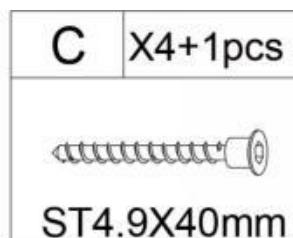
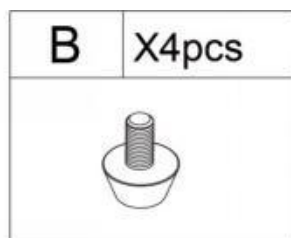
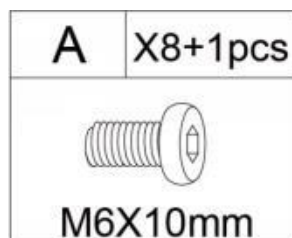

ZAPISZ TĘ INSTRUKCJĘ

PARTS LIST



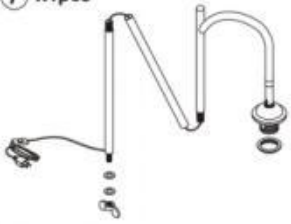
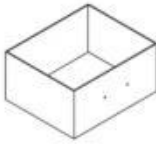
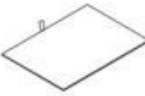

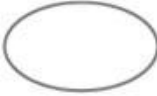

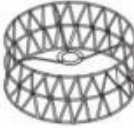
<p>① x2pcs</p> 	<p>② x1pcs</p> 	<p>③ x1pcs</p> 
<p>④ x2pcs</p> 	<p>⑤ x1pcs</p> 	<p>⑥ x1pcs</p> 
<p>⑦ x1pcs</p> 	<p>⑧ x2pcs</p> 	<p>⑨ x2pcs</p> 
<p>⑩ x1pcs</p> 	<p>⑪ x1pcs</p> 	<p>⑫ x1pcs</p> 
<p>⑬ x1pcs</p> 	<p>⑭ x1pcs</p> 	

ASSEMBLY STEP

1

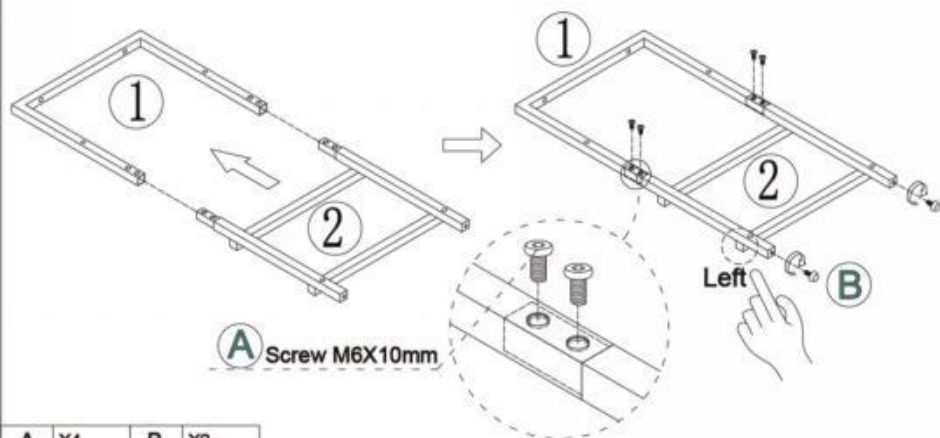

A X4

B X2



2

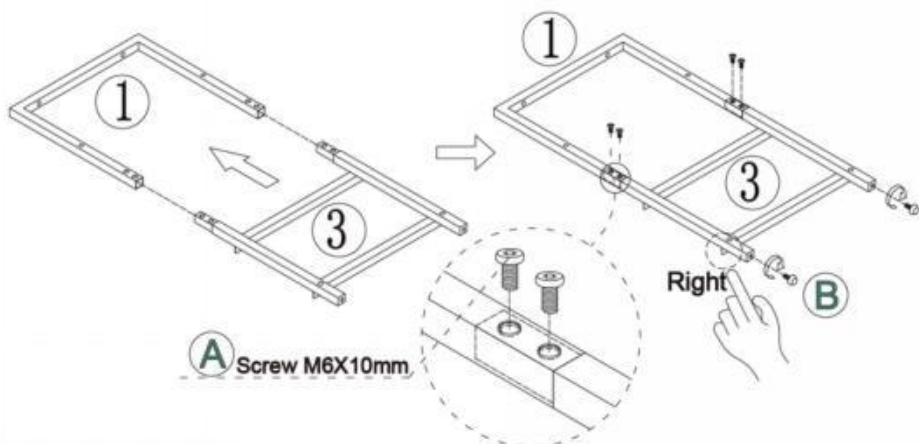

A X4

B X2



3

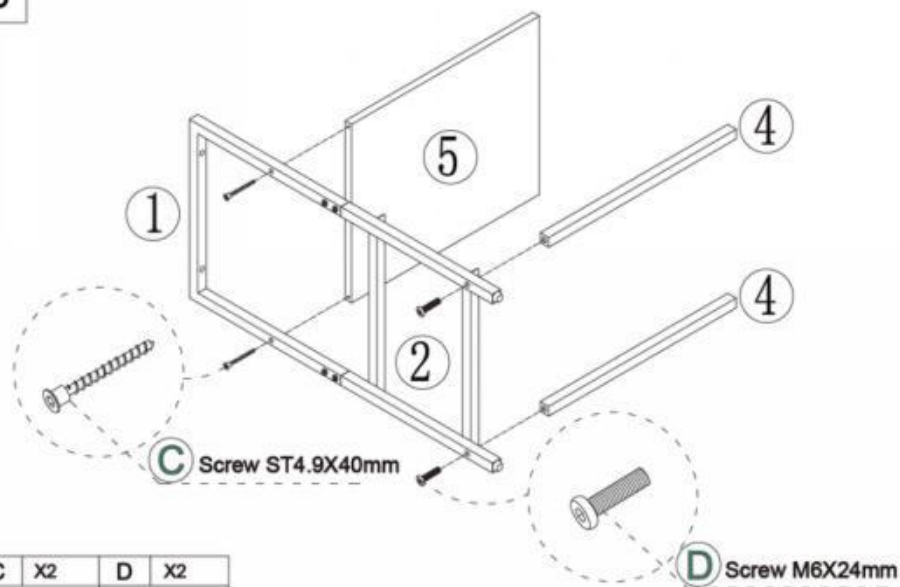

C	X2	D	X2
---	----	---	----

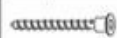

ST4.9X40mm



M6X24mm

4

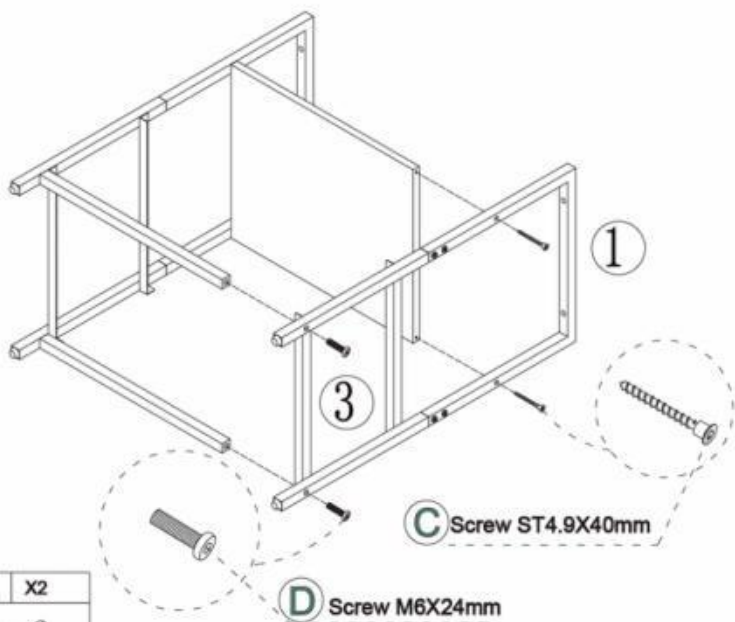

C	X2	D	X2
---	----	---	----

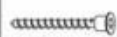

ST4.9X40mm



M6X24mm

5

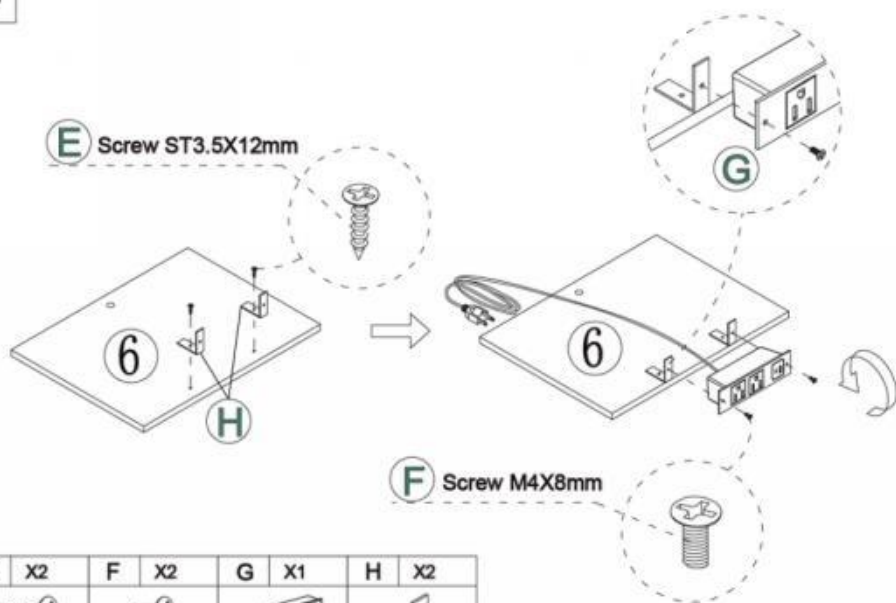

E	X2	F	X2	G	X1	H	X2
ST3.5X12mm		M4X8mm					

6

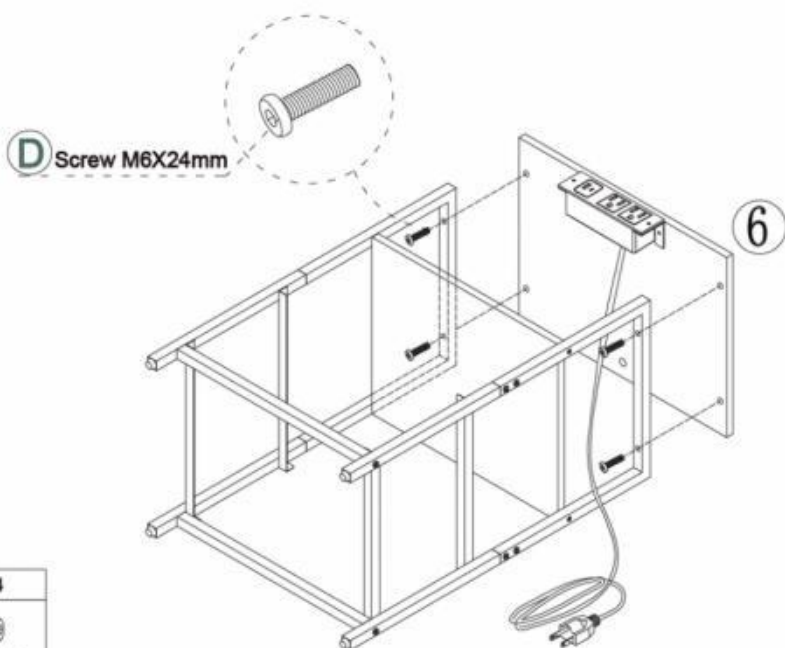

D	X4
M6X24mm	

7

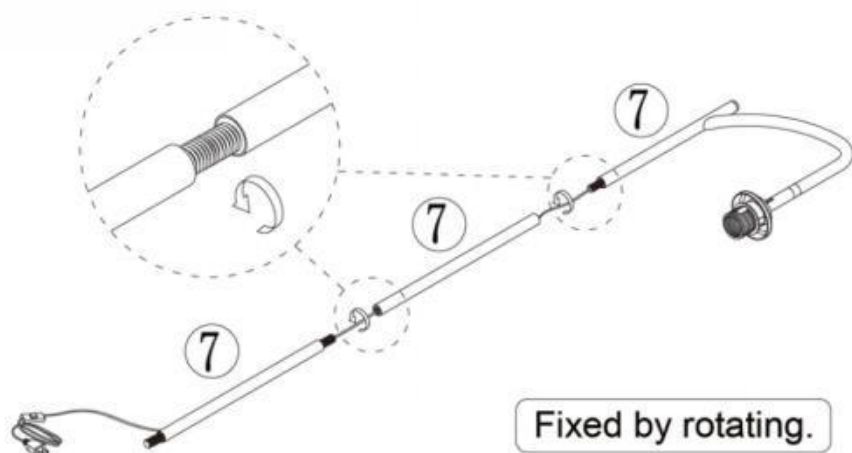

8

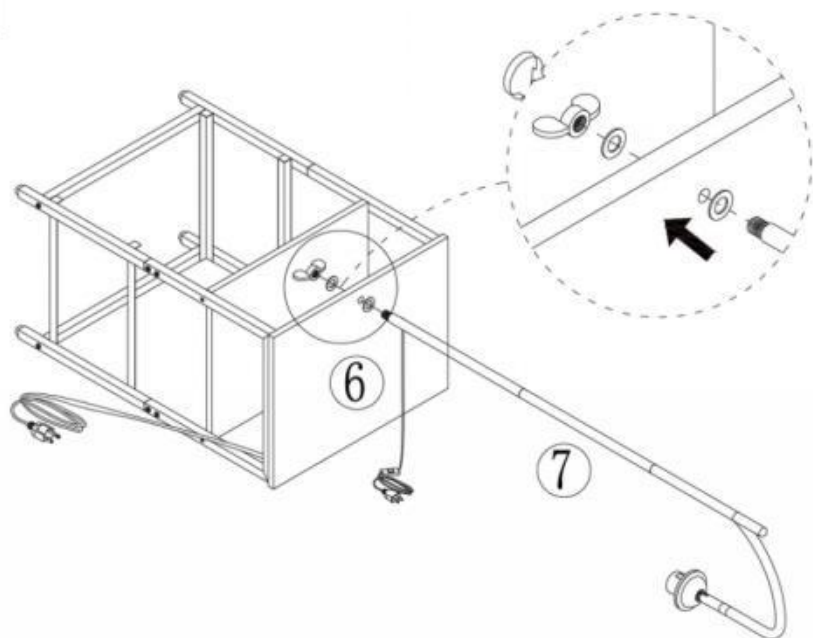

9

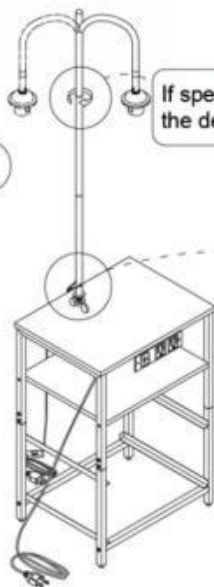

If specific circumstances arise, you can achieve the desired outcome by loosening this joint.

Installation prompt:

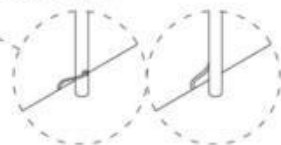

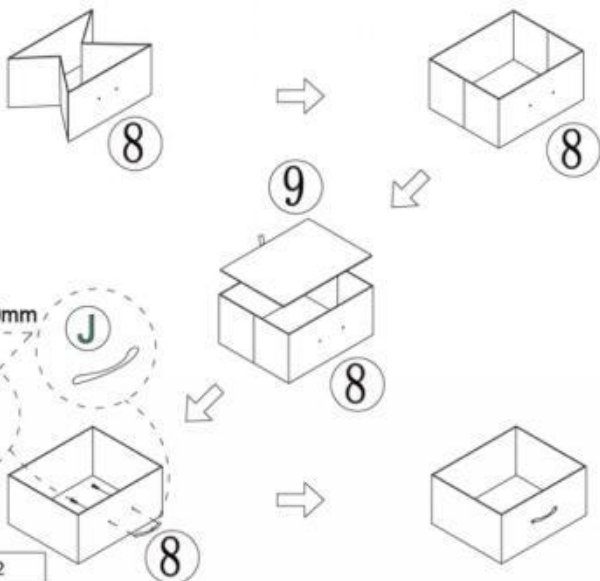

Due to the limitations of the manufacturing process, the position of the cable outlet hole may have deviations. If you have high requirements in this regard, you can wrap the tape around the threaded part in the middle of the lamp post and then try to tighten the lamp post until the outlet hole is completely aligned.

10



I Screw M4X10mm

J

I	X4	J	X2
			
M4X10mm			

X2

11

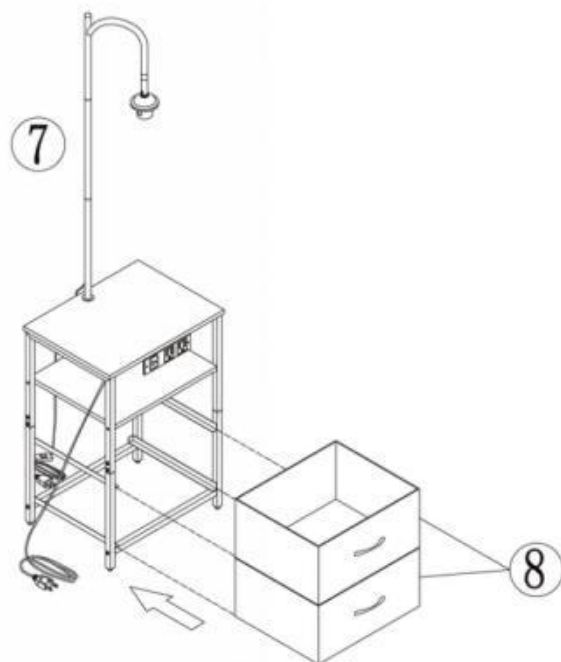

12

Installation prompt:

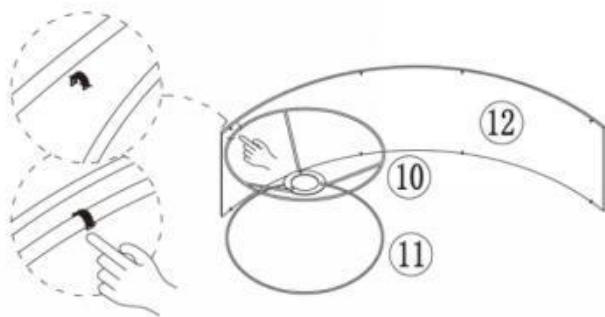

The clips at the top and bottom snap along the iron wire to hold.
The edges of the hin iron sheet are sharp, Be careful to avoid cuts.

13

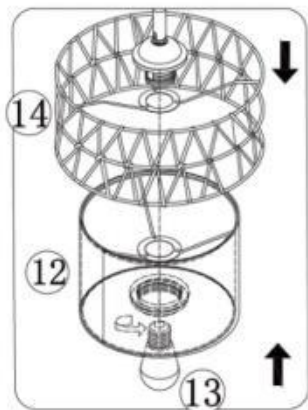
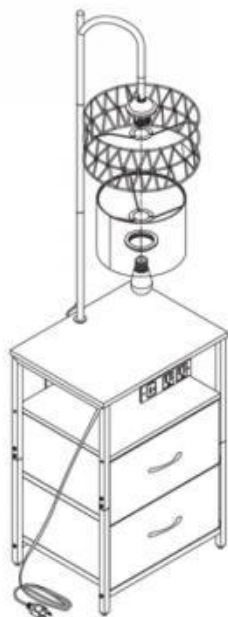

Do not power on during installation

14



PRODUCT PARAMETER

Model	ZH636
Kolor główny	brązowy i czarny
Produkt Rozmiar (D*W*H)	400*300*1500 mm
Waga netto	Okolo 5,39 kg

* Produkty mogą podlegać zmianom dotyczącym specyfikacji, wyglądu i konstrukcji bez wcześniejszego powiadomienia.

Producent: Shanghai muxinmuyeyouxiangongsi

Adres: Shuangchenglu 803nong11hao1602A-1609shi, baoshanqu, szanghaj 200000 CN.

Importowane do Australii: SIHAO PTY LTD. 1 ROKEVA
STREET EASTWOOD NSW 2122 Australia

Importowane do USA: Sanven Technology Ltd. Suite 250, 9166 Anaheim
Place, Rancho Cucamonga, CA 91730

EC	REP
-----------	------------

E-CrossStu GmbH
Mainzer Landstr.69, 60329 Frankfurt am Main.

UK	REP
-----------	------------

YH CONSULTING LIMITED.
C/O YH Consulting Limited Office 147, Centurion
House, London Road, Staines-upon-Thames, Surrey,
TW18 4AX



VEVOR

Upgrade · The Home Creator Way

METALEN BIJZETTAFEL



GEBRUIKERSHANDLEIDING

MODEL: ZH636

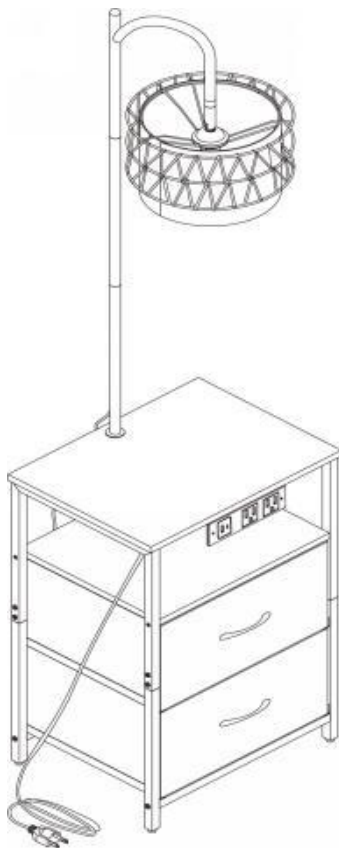
MODEL: ZH636



Dit is de originele handleiding. Lees alle instructies in de handleiding zorgvuldig door voordat u het product in gebruik neemt. VEVOR behoudt zich het recht voor om de gebruikershandleiding anders te interpreteren. Het uiterlijk van het product kan afwijken van het product dat u ontvangt. Wij zullen u niet opnieuw informeren over eventuele technologische of software-updates voor ons product.

	<p>Waarschuwing: Om het risico op letsel te verminderen, dient de gebruiker de gebruiksaanwijzing zorgvuldig te lezen.</p>
	<p>Waarschuwing: alleen voor gebruik binnenshuis.</p>
	<p>FCC-informatie: LET OP: Wijzigingen of aanpassingen die niet uitdrukkelijk zijn goedgekeurd door de partij die verantwoordelijk is voor de naleving, kunnen de bevoegdheid van de gebruiker om de apparatuur te bedienen ongeldig maken!</p> <p>Dit apparaat voldoet aan Deel 15 van de FCC-regels. De werking is onderworpen aan de volgende twee voorwaarden:</p> <ol style="list-style-type: none"> 1) Dit product kan schadelijke interferentie veroorzaken. 2) Dit product moet alle ontvangen storingen kunnen verdragen, inclusief storingen die een ongewenste werking kunnen veroorzaken.

SAFETY INSTRUCTIONS

WAARSCHUWING:

Lees deze informatie aandachtig door voordat u dit product gebruikt. Het niet nalezen van deze instructies kan ernstig letsel tot gevolg hebben.

Montagevoorzorgsmaatregelen

73. Monteer het product uitsluitend volgens deze instructies. Onjuiste montage kan gevaarlijke situaties opleveren.
74. Draag tijdens de montage een ANSI-goedgekeurde veiligheidsbril en stevige werkhandschoenen.
75. Zorg ervoor dat de montageruimte schoon en goed verlicht is.
76. Als er na het uitpakken defecte en/of ontbrekende onderdelen zijn, stop dan onmiddellijk met de montage en neem contact met ons op.
77. Niet monteren als u moe bent of onder invloed bent van alcohol, drugs of medicijnen.
78. De producteigenschappen gelden alleen voor correct en volledig geassembleerde producten.
79. Monteer de bijzettafel op een vlakke, horizontale, harde en gladde ondergrond die het metalen tafeltje veilig kan dragen.
80. Gebruik indien mogelijk elektrisch gereedschap om de montage te vergemakkelijken.
81. Het wordt aanbevolen dat de montage door minimaal twee volwassenen wordt uitgevoerd. Lees de montage-instructies zorgvuldig door voordat u begint met de montage en volg elke stap nauwkeurig op.
82. Houd er rekening mee dat sommige onderdelen een reserveonderdeel hebben.
83. Gebruik een elektrische boormachine om gaten in de muur te maken. Meet de afstand tussen de twee gaten zorgvuldig op en zorg ervoor dat ze waterpas zijn.
84. Raadpleeg voor meer informatie over de onderdelen die op de volgende pagina's worden vermeld, het montageschema in deze

handleiding. Pak alle onderdelen uit en sorteer ze in een schone werkruimte.

Neem voorzorgsmaatregelen.

61. De aangegeven waarde niet overschrijden. draagvermogen.
62. Gebruik dit product uitsluitend op een vlakke, horizontale, harde en gladde ondergrond die een volledig beladen metalen bijzettafel veilig kan dragen.
63. Gebruik uitsluitend zoals bedoeld.
64. Controleer het product voor elk gebruik; gebruik het product niet als onderdelen loszitten of beschadigd zijn.
65. Dit product moet stevig aan de muur worden bevestigd om letsel door vallen of kantelen te voorkomen.
66. Bevestig het artikel altijd stevig aan de muur voordat u het gebruikt.
67. Dit product is niet bedoeld voor gebruik door kinderen jonger dan 5 jaar. Kinderen dienen onder toezicht van een volwassene te staan om het product te gebruiken.
68. Het is kinderen verboden om op het product te klimmen of te spelen om ernstig letsel door omvallen te voorkomen.
69. Houd tijdens de montage alle kleine onderdelen buiten het bereik van kinderen. Inslikken of inademen kan dodelijk zijn.
- 70.** Om verstikkingsgevaar te voorkomen, dient u alle onderdelen en verpakkingen (folie, plastic zakken, schuim, enz.) buiten het bereik van baby's en kinderen te houden.





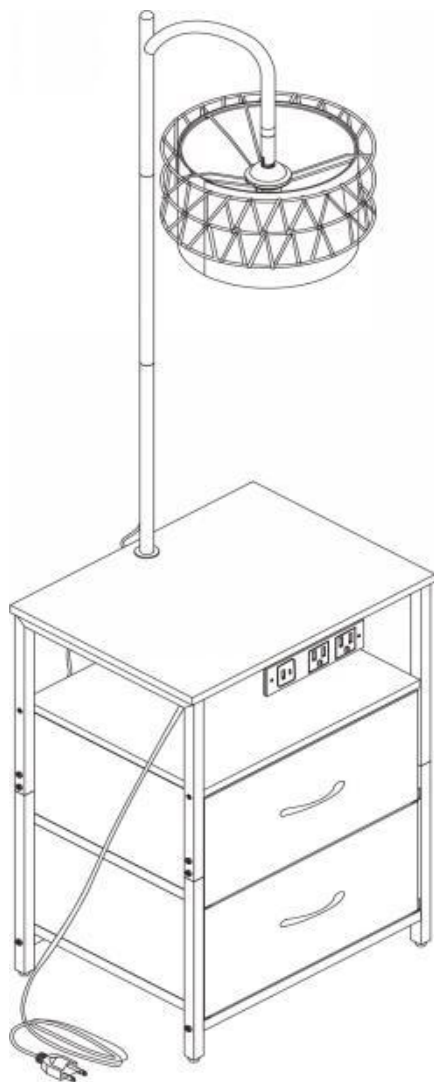

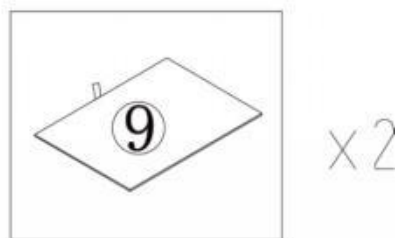
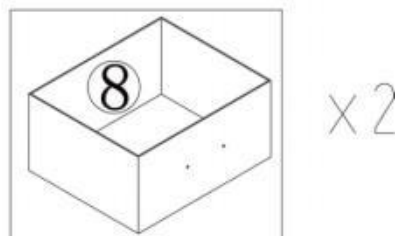
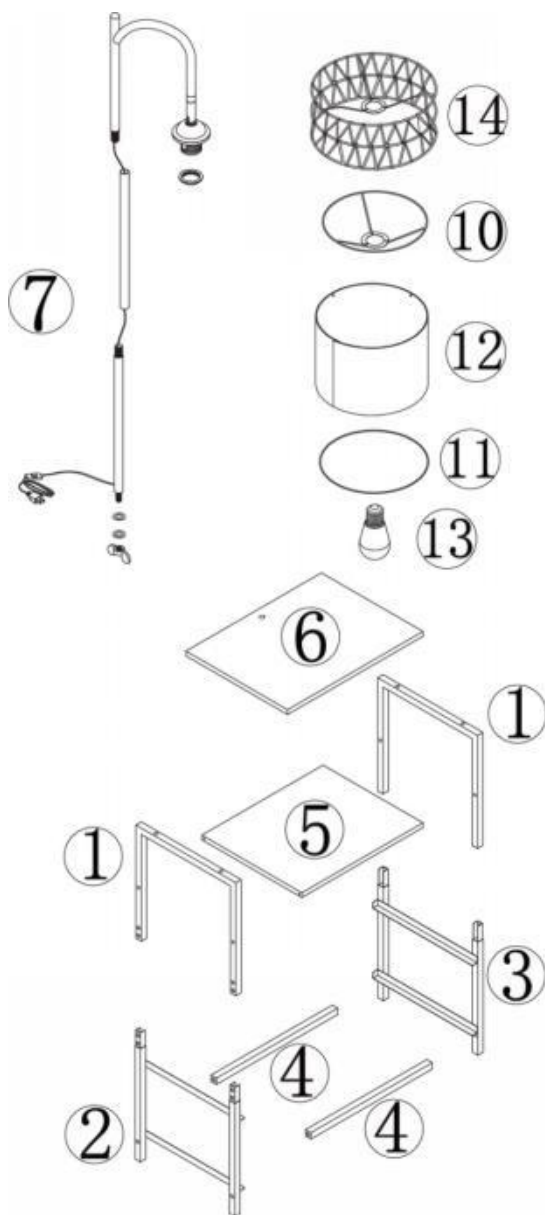

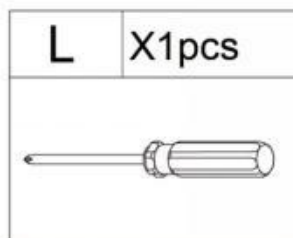
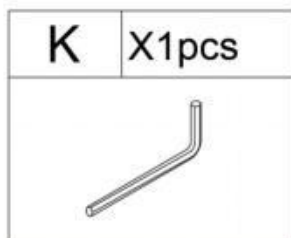
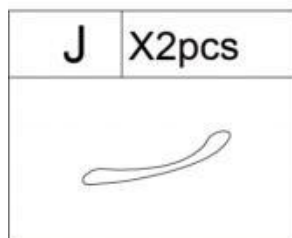
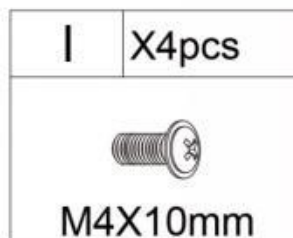
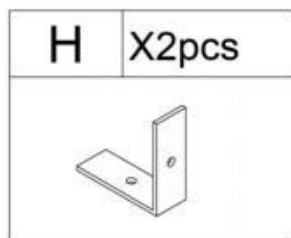
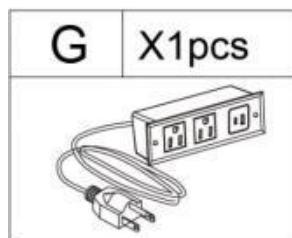
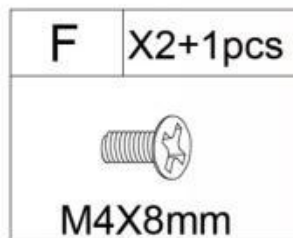
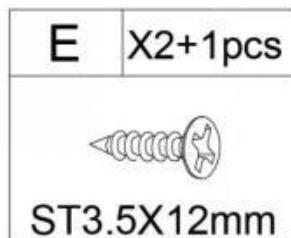
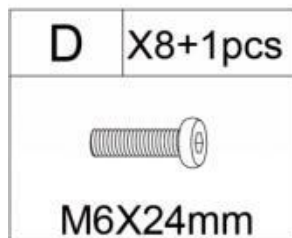
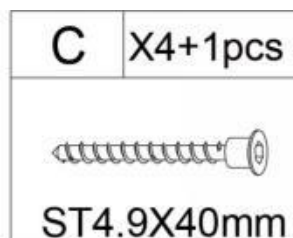
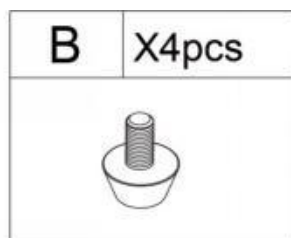
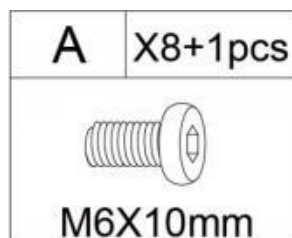

BEWAAR DEZE HANDLEIDING

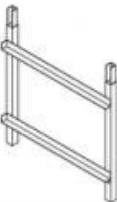
PARTS LIST



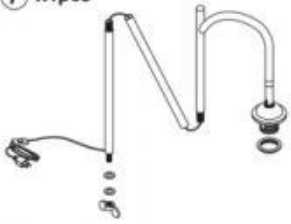
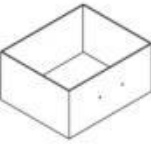
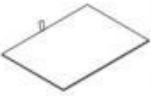

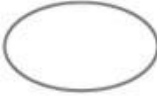

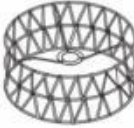
<p>① x2pcs</p> 	<p>② x1pcs</p> 	<p>③ x1pcs</p> 
<p>④ x2pcs</p> 	<p>⑤ x1pcs</p> 	<p>⑥ x1pcs</p> 
<p>⑦ x1pcs</p> 	<p>⑧ x2pcs</p> 	<p>⑨ x2pcs</p> 
<p>⑩ x1pcs</p> 	<p>⑪ x1pcs</p> 	<p>⑫ x1pcs</p> 
<p>⑬ x1pcs</p> 	<p>⑭ x1pcs</p> 	

ASSEMBLY STEP

1

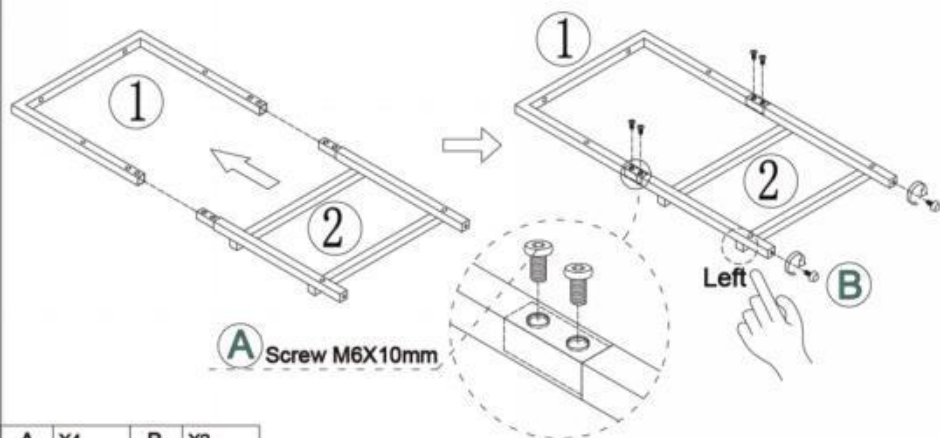

A X4

B X2



2

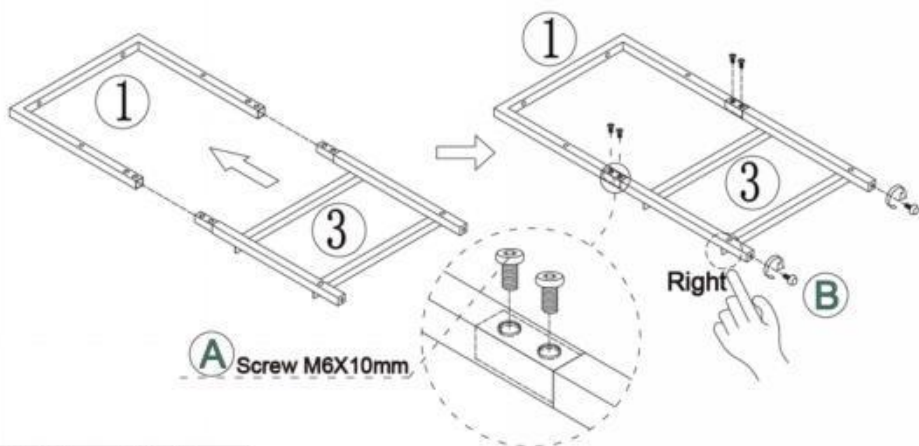

A X4

B X2



3

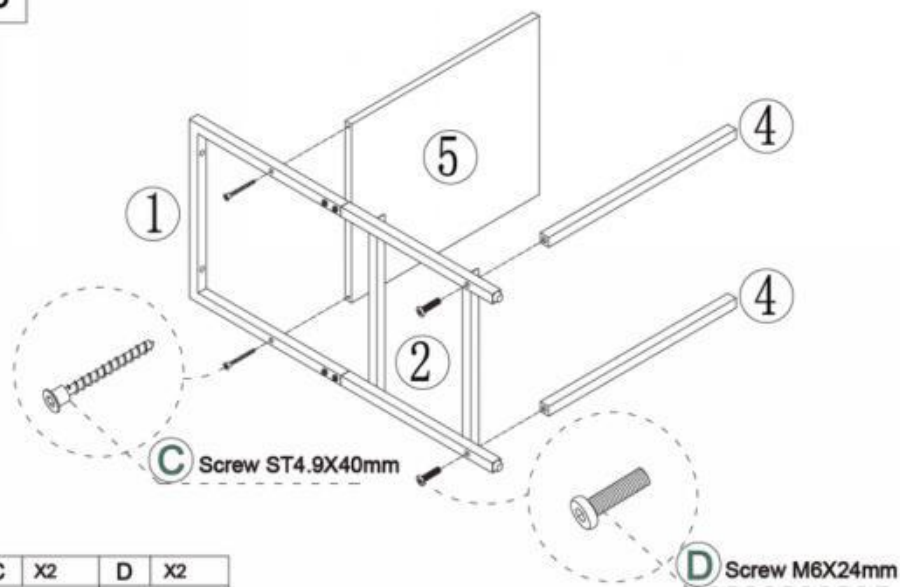

C	X2	D	X2
---	----	---	----

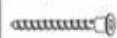

ST4.9X40mm



M6X24mm

4

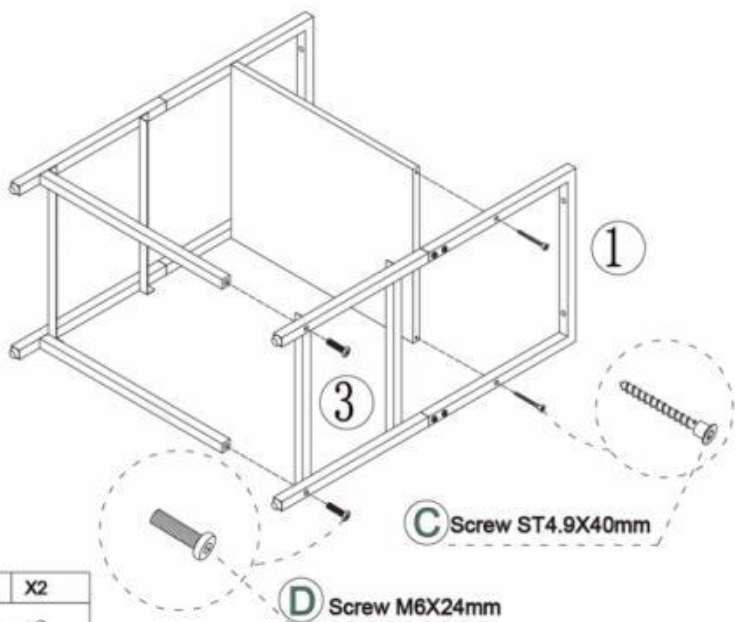

C	X2	D	X2
---	----	---	----

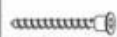





ST4.9X40mm

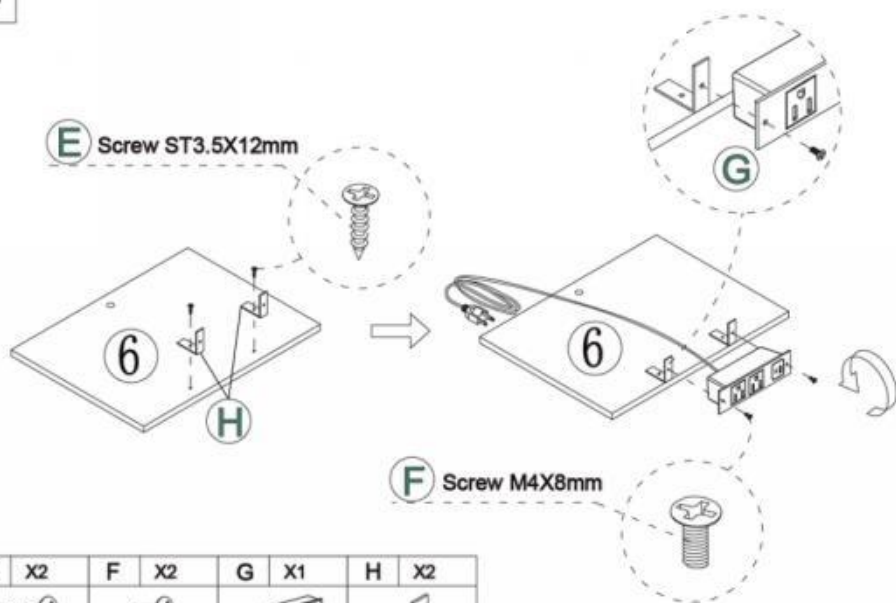

M6X24mm

5



E	X2	F	X2	G	X1	H	X2
							
ST3.5X12mm		M4X8mm					

6

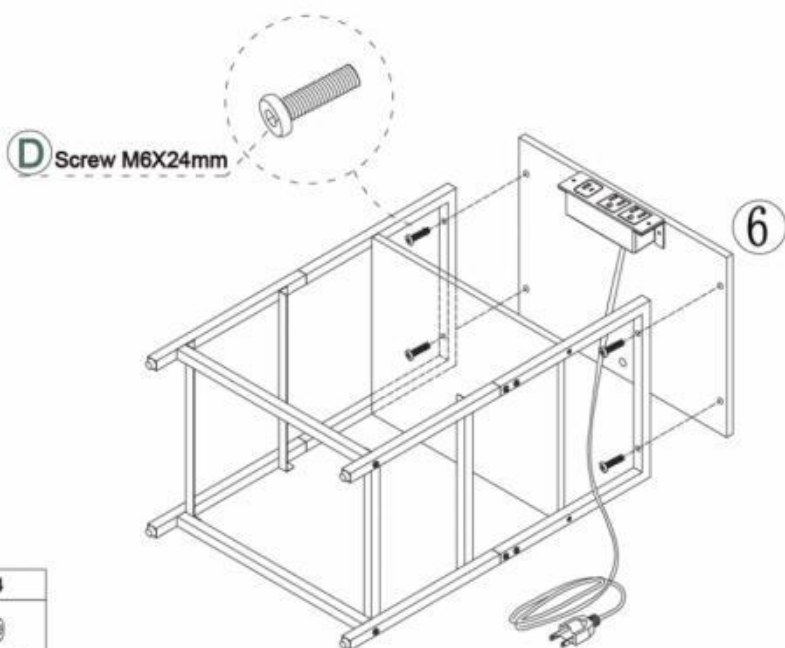

D X4



M6X24mm

7

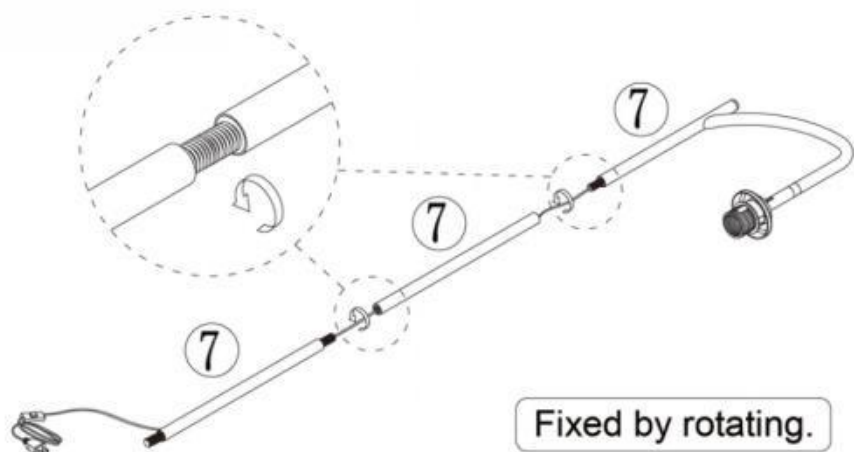

8

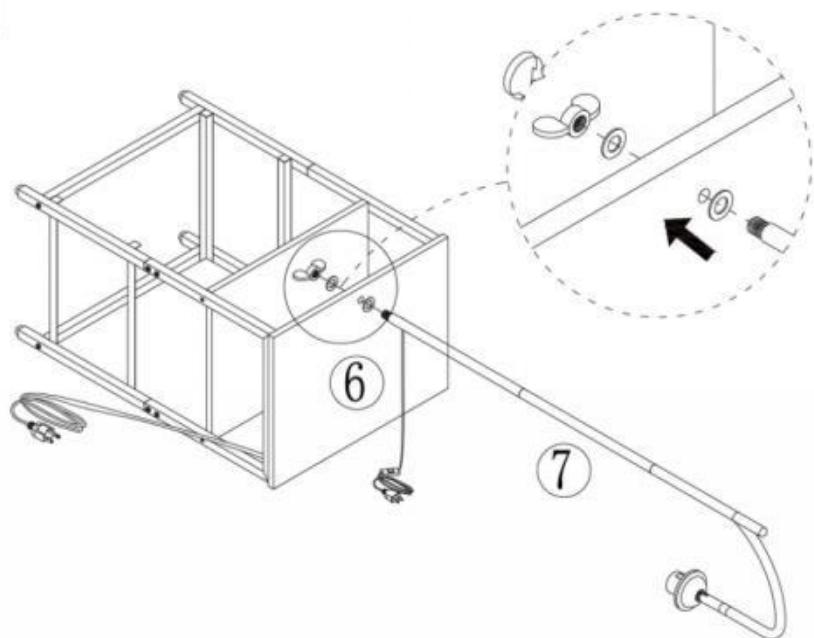

9

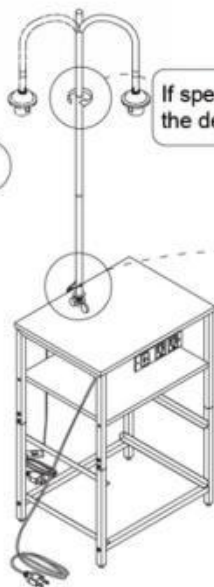

If specific circumstances arise, you can achieve the desired outcome by loosening this joint.

Installation prompt:

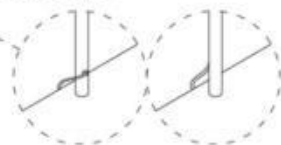

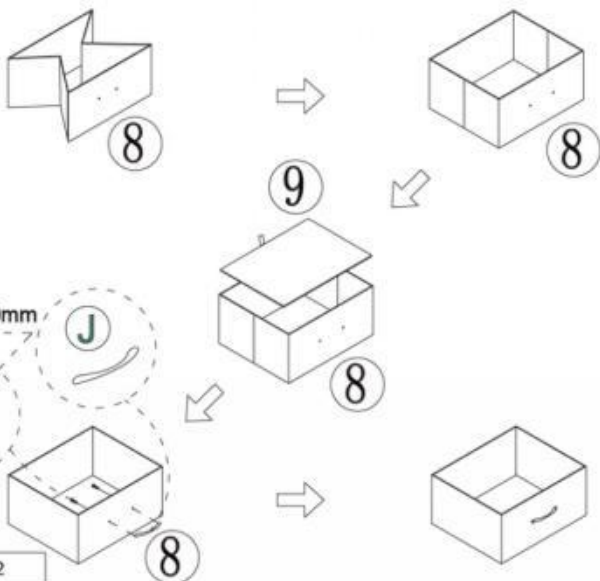

Due to the limitations of the manufacturing process, the position of the cable outlet hole may have deviations. If you have high requirements in this regard, you can wrap the tape around the threaded part in the middle of the lamp post and then try to tighten the lamp post until the outlet hole is completely aligned.

10



I Screw M4X10mm

J

I	X4	J	X2
			
M4X10mm			

X2

11

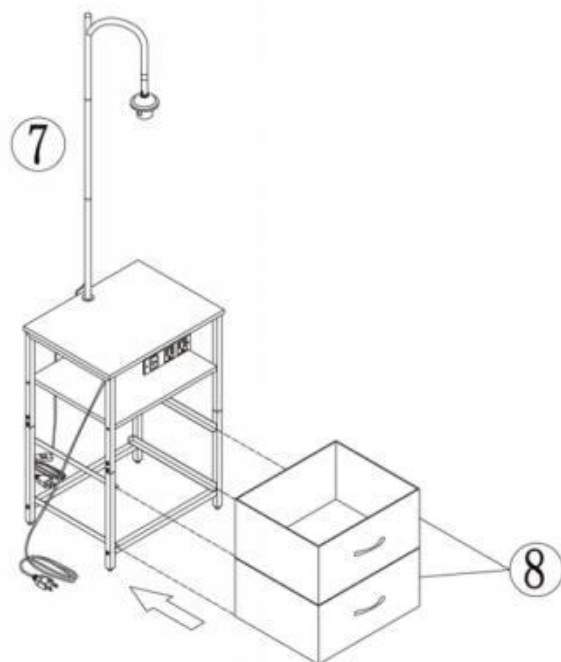

12

Installation prompt:

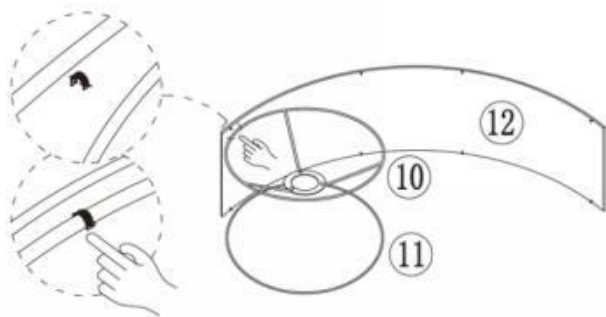
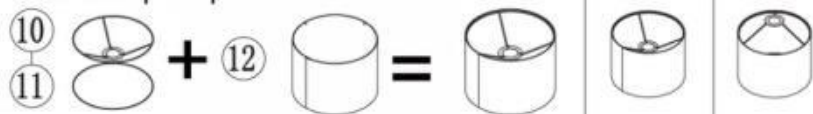

The clips at the top and bottom snap along the iron wire to hold.
The edges of the hin iron sheet are sharp, Be careful to avoid cuts.

13

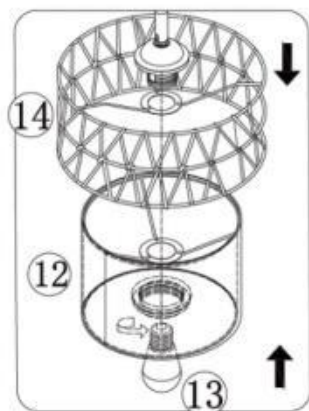
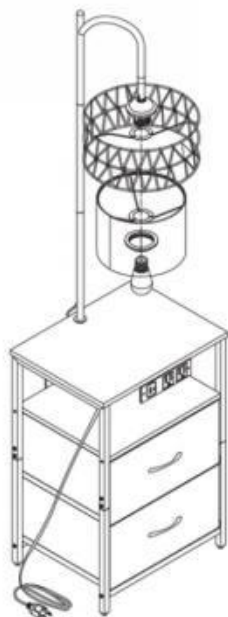

Do not power on during installation

14

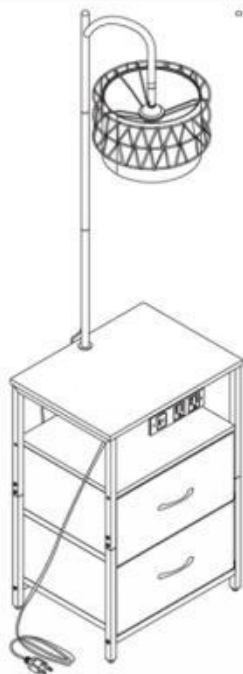

PRODUCT PARAMETER

Model	ZH636
Hoofdkleur	bruin en zwart
Product Maat (D*W*H)	400*300*1500 mm
Nettogewicht	Ongeveer 5,39 kg

* Producteigenschappen, zoals specificaties, uiterlijk en ontwerp, kunnen zonder voorafgaande kennisgeving worden gewijzigd.

Fabrikant: Shanghaimuxinmuyeyouxiangongsi

Adres: Shuangchenglu 803nong11hao1602A-1609shi, baoshanqu, shanghai 200000 CN.

Geïmporteerd naar Australië: SIHAO PTY LTD. 1 ROKEVA STREET, EASTWOOD NSW 2122 Australië

Geïmporteerd naar de VS: Sanven Technology Ltd. Suite 250, 9166 Anaheim Place, Rancho Cucamonga, CA 91730

EC	REP
-----------	------------

E-CrossStu GmbH
Mainzer Landstr.69, 60329 Frankfurt am Main.

UK	REP
-----------	------------

YH CONSULTING LIMITED.
C/O YH Consulting Limited Office 147, Centurion House, London Road, Staines-upon-Thames, Surrey, TW18 4AX



VEVOR

Upgrade · The Home Creator Way

SIDOBORD I METALL



ANVÄNDARMANUAL

MODELL: ZH636

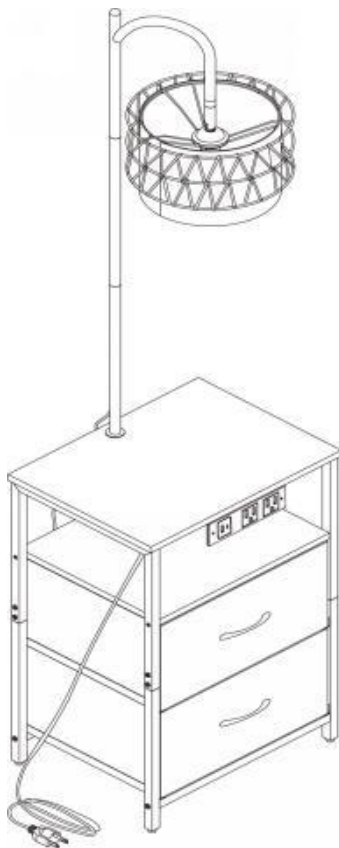
MODELL: ZH636



Detta är originalinstruktionerna, vänligen läs alla instruktioner noggrant innan du använder produkten. VEVOR förbehåller sig en tydlig tolkning av vår användarmanual. Produktens utseende ska vara beroende av den produkt du mottagit. Vi ber om ursäkt för att vi inte kommer att informera dig igen om det finns några teknik- eller programuppdateringar för vår produkt.

	Varning – För att minska risken för skador måste användaren läsa instruktionsmanualen noggrant.
	Varning - Endast för inomhusbruk
	FCC-information: VARNING: Ändringar eller modifieringar som inte uttryckligen godkänts av den part som ansvarar för efterlevnaden kan upphäva användarens rätt att använda utrustningen! Denna enhet uppfyller del 15 i FCC-reglerna. Användning är underkastad följande två villkor: 1) Denna produkt kan orsaka skadliga störningar. 2) Denna produkt måste acceptera alla mottagna störningar, inklusive störningar som kan orsaka oönskad funktion.

SAFETY INSTRUCTIONS

WARNING:

Läs detta material innan du använder produkten. Underlåtenhet att göra det kan leda till allvarliga skador.

Monteringsförsiktighetsåtgärder

85. Montera endast enligt dessa instruktioner. Felaktig montering kan orsaka risker.
86. Använd ANSI-godkända skyddsglasögon och kraftiga arbetshandskar under monteringen.
87. Håll samlingsområdet rent och väl upplyst.
88. Om det finns defekta och/eller saknade delar efter upppackning, vänligen avbryt monteringen omedelbart och kontakta oss.
89. Montera inte om du är trött eller påverkad av alkohol, droger eller mediciner.
90. Produktens egenskaper gäller endast korrekt och fullständigt monterade produkter.
91. Montera på en plan, jämn, hård och slät yta som säkert kan stödja metallsidobordet.
92. Om möjligt kan du använda elverktyg för att underlätta monteringen.
93. Det rekommenderas att monteringen utförs av minst två vuxna. Läs monteringsanvisningarna före montering och följ noggrant varje steg som beskrivs.
94. Observera att vissa typer av delar har reservdelar.
95. Använd en elektrisk borr för att borra hål i väggen. Mät noggrant avståndet mellan de två hålen och håll dem i jämnhöjd.
96. För ytterligare information om delarna som listas på följande sidor, se monteringsdiagrammet i denna manual. Packa upp och separera alla delar på en ren arbetsyta.

Använd försiktighetsåtgärder

71. Överskrid inte angivna viktkapacitet.
72. Använd endast på en plan, jämn, hård och slät yta som säkert kan bära ett fullt lastat metallsidobord .
73. Använd endast som avsett.
74. Kontrollera före varje användning; använd inte om delar är lösa eller skadade.
75. Denna produkt måste fästas ordentligt på väggen för att undvika personskador orsakade av fall/lutning.
76. Fäst alltid föremålet ordentligt på väggen inför användning.
77. Den är inte avsedd att användas av barn under 5 år. Barn måste övervakas av en vuxen för att få använda produkten.
78. Det är förbjudet för barn att klättra eller leka på produkten för att undvika allvarliga kroppsskador orsakade av att den välter.
79. Förvara smådelar utom räckhåll för barn under monteringsprocessen. De kan vara dödliga om de sväljs eller inandas.
- 80.** För att undvika potentiella kvävningsrisker, håll alla delar och förpackningar (filmer, plastpåsar och skumgummi etc.) utom räckhåll för spädbarn och barn.





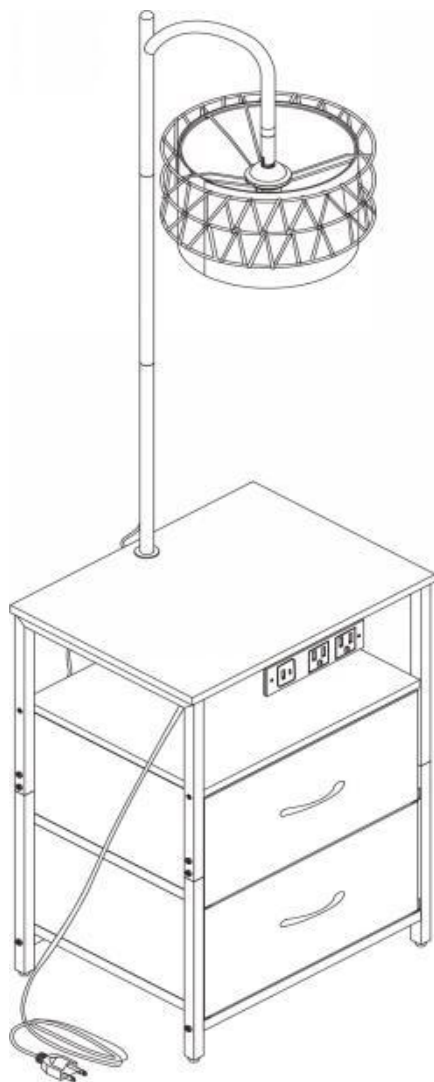

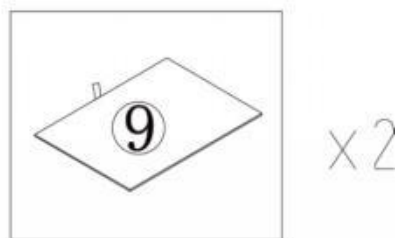
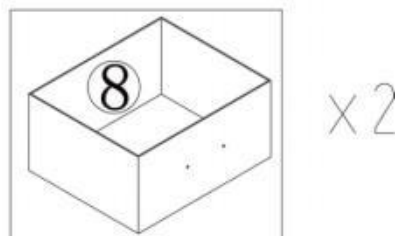
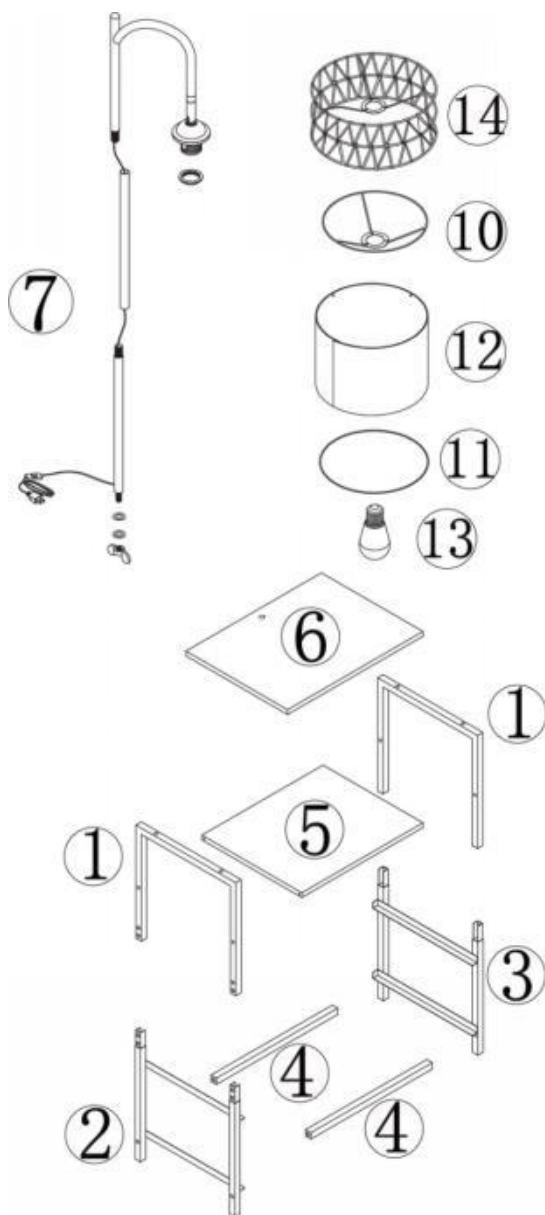

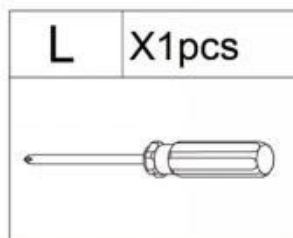
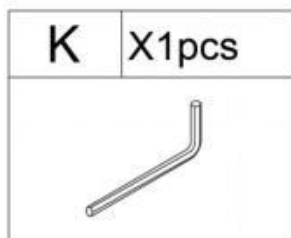
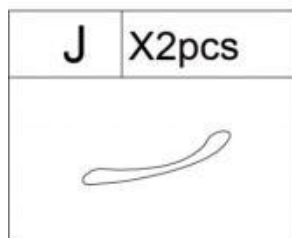
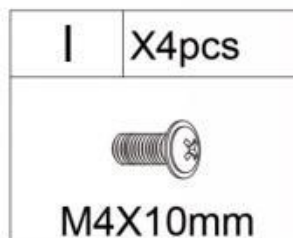
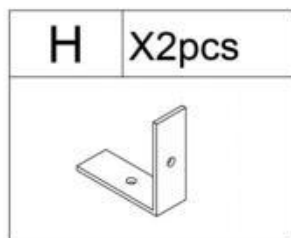
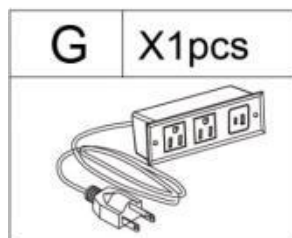
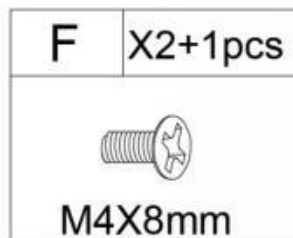
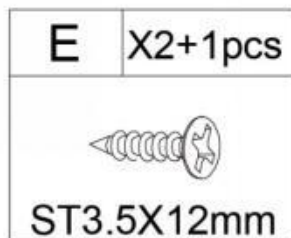
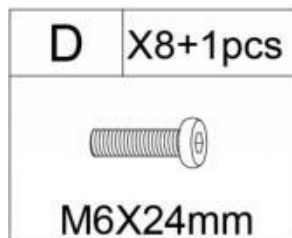
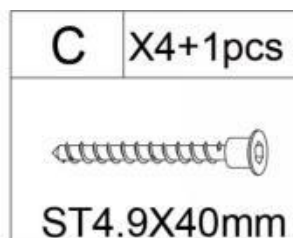
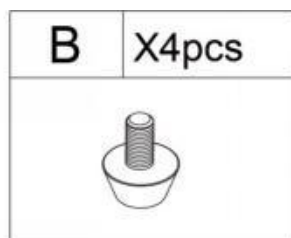
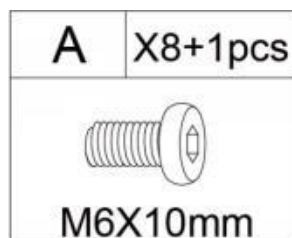

SPARA DENNA HANDBOK

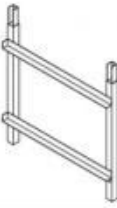
PARTS LIST



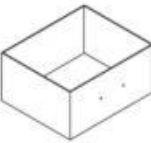
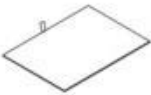

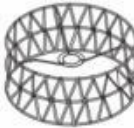

<p>① x2pcs</p> 	<p>② x1pcs</p> 	<p>③ x1pcs</p> 
<p>④ x2pcs</p> 	<p>⑤ x1pcs</p> 	<p>⑥ x1pcs</p> 
<p>⑦ x1pcs</p> 	<p>⑧ x2pcs</p> 	<p>⑨ x2pcs</p> 
<p>⑩ x1pcs</p> 	<p>⑪ x1pcs</p> 	<p>⑫ x1pcs</p> 
<p>⑬ x1pcs</p> 	<p>⑭ x1pcs</p> 	

ASSEMBLY STEP

1

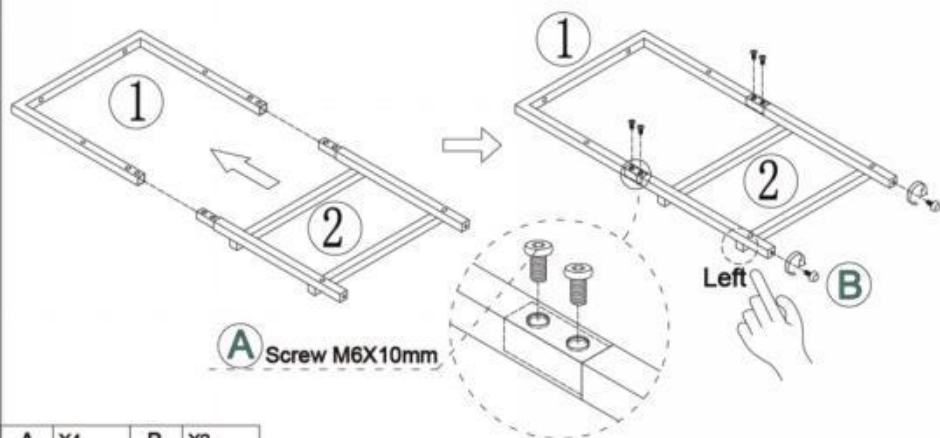

A X4

B X2



2

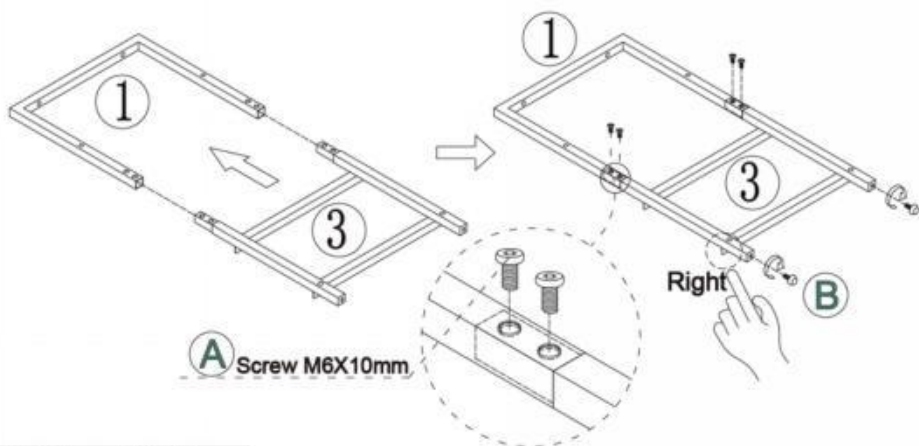

A X4

B X2



3

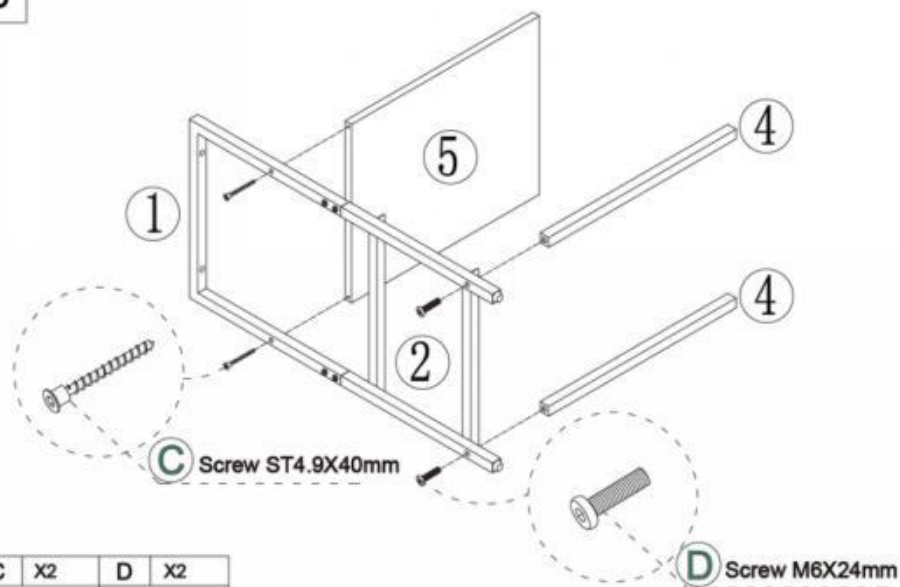

C	X2	D	X2
---	----	---	----



4

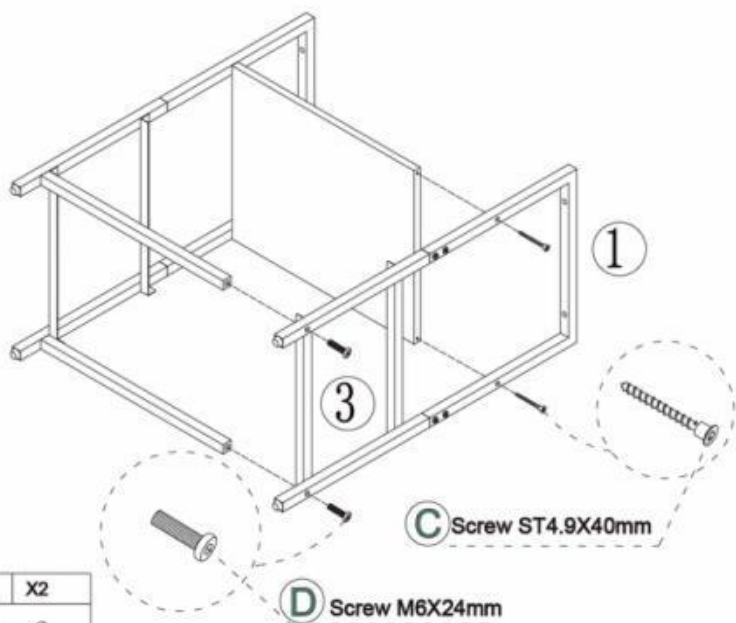



C	X2	D	X2
---	----	---	----



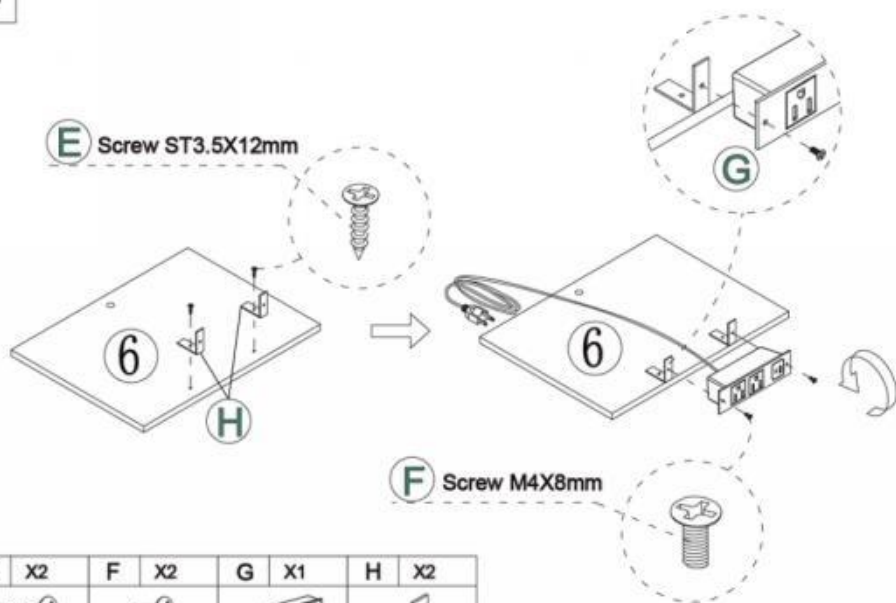

5

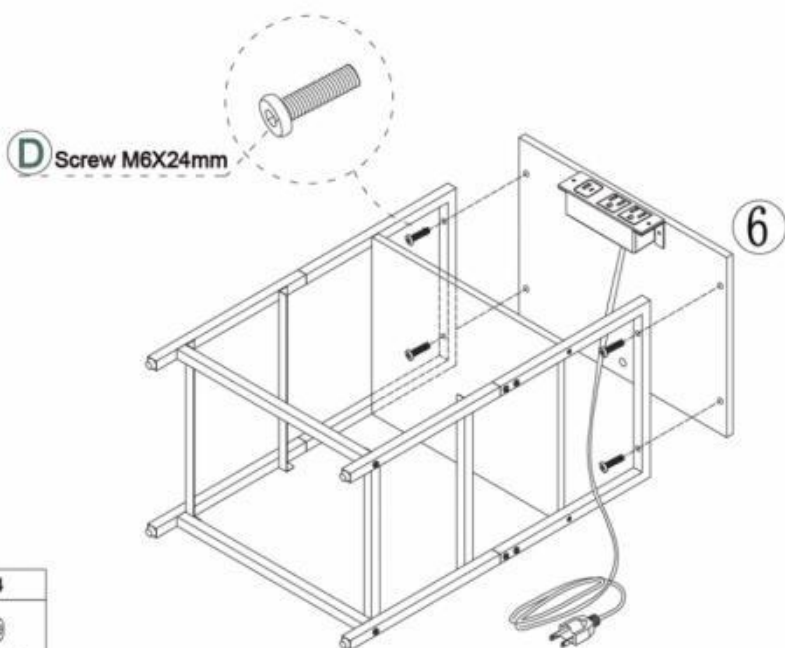

E	X2	F	X2	G	X1	H	X2
							
ST3.5X12mm		M4X8mm					

6



D	X4
	
M6X24mm	

7

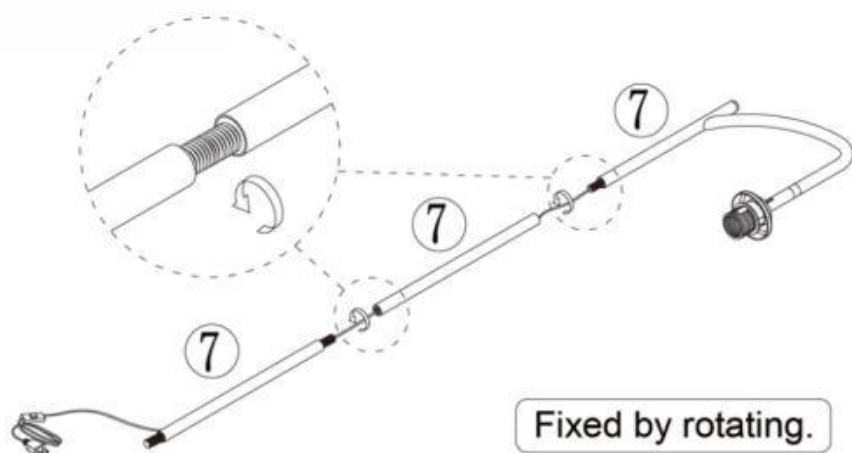

8

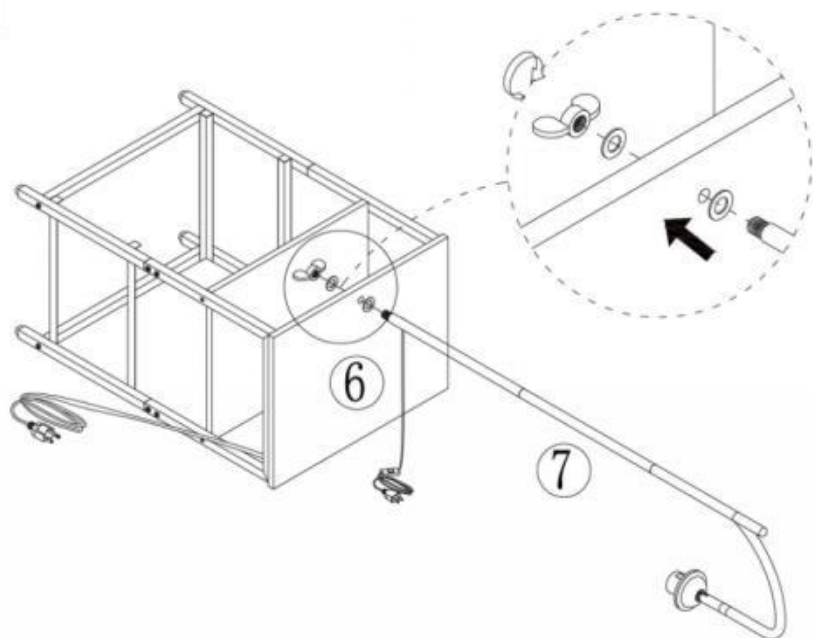

9

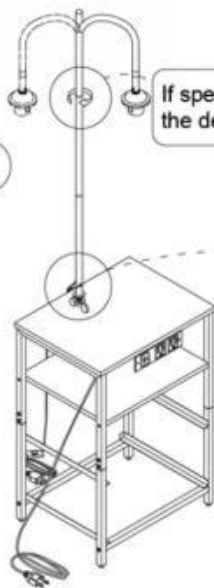

If specific circumstances arise, you can achieve the desired outcome by loosening this joint.

Installation prompt:

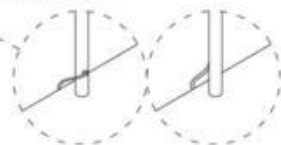

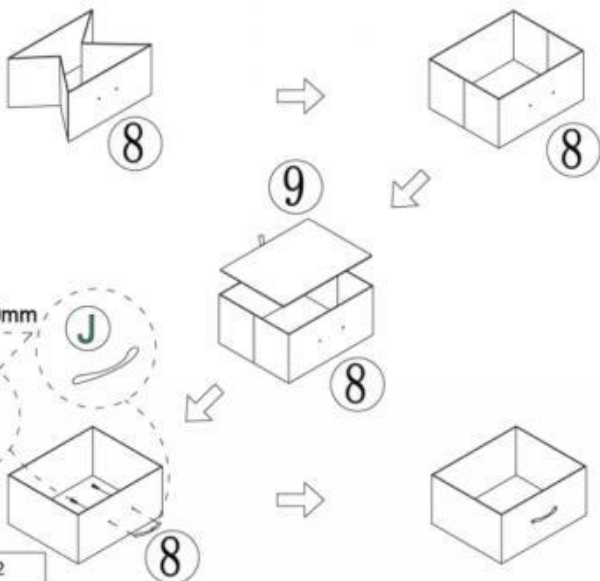

Due to the limitations of the manufacturing process, the position of the cable outlet hole may have deviations. If you have high requirements in this regard, you can wrap the tape around the threaded part in the middle of the lamp post and then try to tighten the lamp post until the outlet hole is completely aligned.

10



I Screw M4X10mm

J

I	X4	J	X2
			
M4X10mm			

X2

11

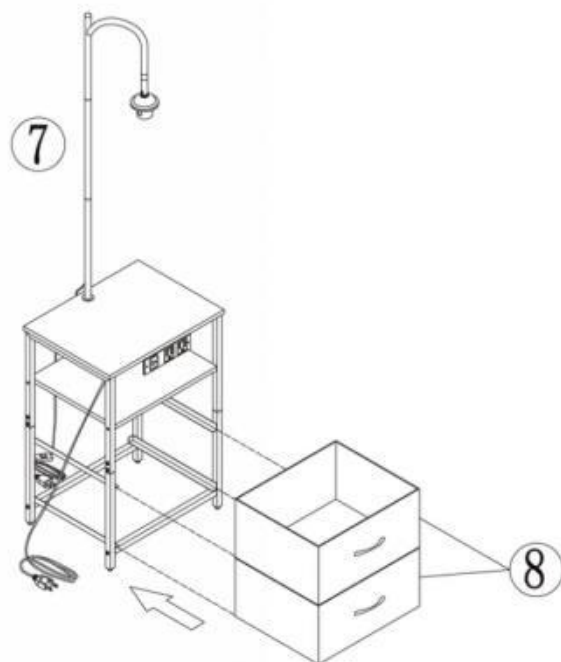

12

Installation prompt:

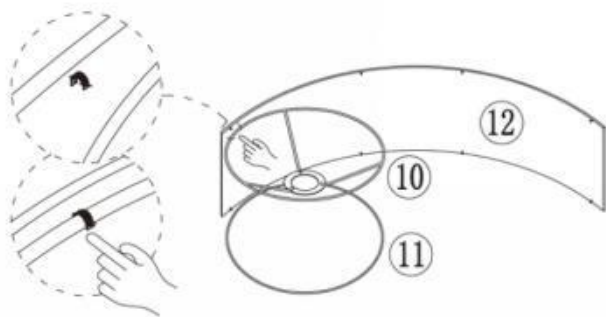

The clips at the top and bottom snap along the iron wire to hold.
The edges of the hin iron sheet are sharp, Be careful to avoid cuts.

13

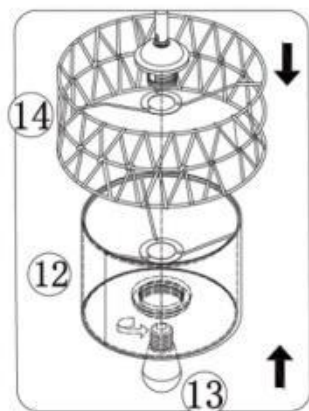
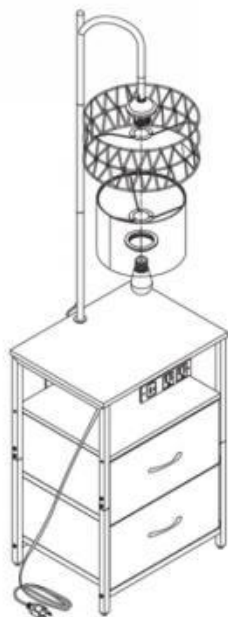

Do not power on during installation

14

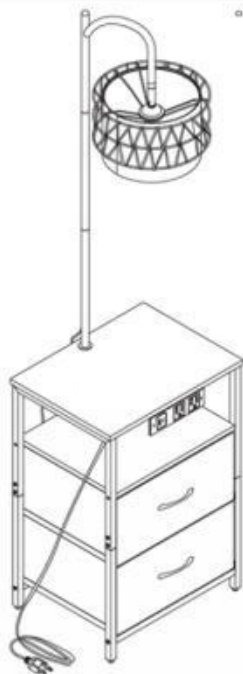

PRODUCT PARAMETER

Modell	ZH636
Huvudfärg	brunt och svart
Produkt Storlek (D*B*H)	400*300*1500mm
Nettovikt	Cirka 5,39 kg

* Produkters specifikationer, utseende och design kan komma att ändras utan föregående meddelande.

Tillverkare: Shanghai muxinmuyeyouxiangongsi

Adress: Shuangchenglu 803nong11hao1602A-1609shi, baoshanqu, shanghai 200000 CN.

Importerad till Australien: SIHAO PTY LTD. 1 ROKEVA
STREETEASTWOOD NSW 2122 Australien

Importerad till USA: Sanven Technology Ltd. Suite 250, 9166 Anaheim
Place, Rancho Cucamonga, CA 91730

EC	REP
-----------	------------

E-CrossStu GmbH
Mainzer Landstr.69, 60329 Frankfurt am Main.

UK	REP
-----------	------------

YH CONSULTING LIMITED.
C/O YH Consulting Limited Office 147, Centurion
House, London Road, Staines-upon-Thames, Surrey,
TW18 4AX

