

Large Desk

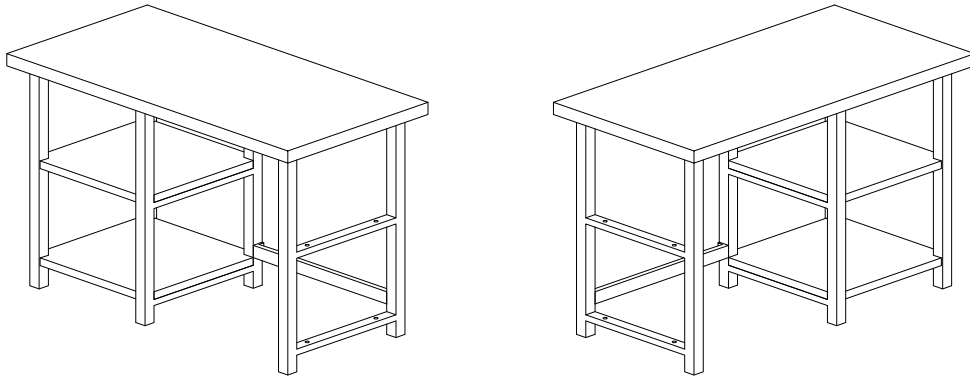





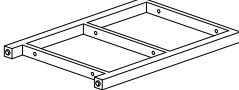
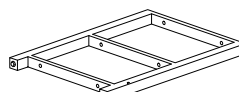
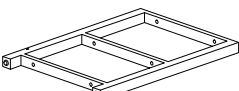
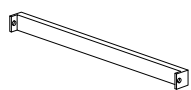

Thank you for purchasing the Large Desk. We have found it helpful to have a second person present during the assembly process.

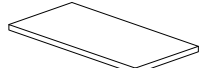
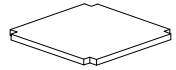
Large Desk Assembly Instructions

Parts

NO.	DRAWING	DESCRIPTION	QTY
A		METAL FRAME	1
B		METAL FRAME	1
C		METAL FRAME	1
D		BACK RAIL	1

NO.	DRAWING	DESCRIPTION	QTY
E		TABLE TOP	1
F		SHELF	2

NO.	DRAWING	DESCRIPTION	QTY
G		M6x35MM BOLT	14
H		M6x20MM BOLT	2
I		ALLEN KEY	2
J		M6x15MM BOLT	4
K		CONNECTOR BOLT	4

IF YOU WANT SUB ASSEMBLY ON LEFT HAND

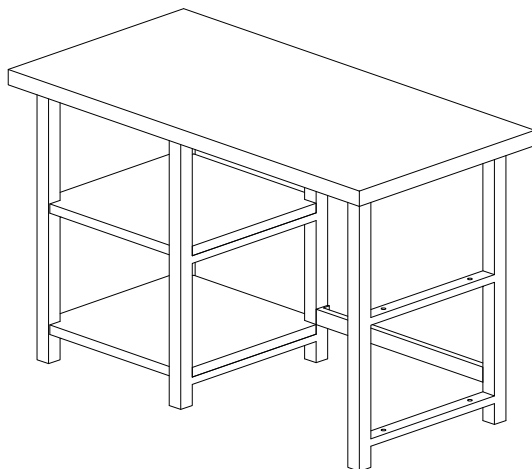

Step 1

Read through these instructions thoroughly before beginning assembly. We have found this to be of great value when assembling this product.

Step 2

Remove all parts and hardware from packing material. Wooden pieces should be placed on a non-abrasive surface to prevent damage to the finish

Step 3

Lay Metal Frame Assembly (A) & (B) on a non-abrasive surface. Attach Shelf (F) to Metal Frame (A) & (B) using 8-M6x35MM Hex Bolts (G). NOTE: DO NOT TIGHTEN ALL BOLTS AT THIS TIME !

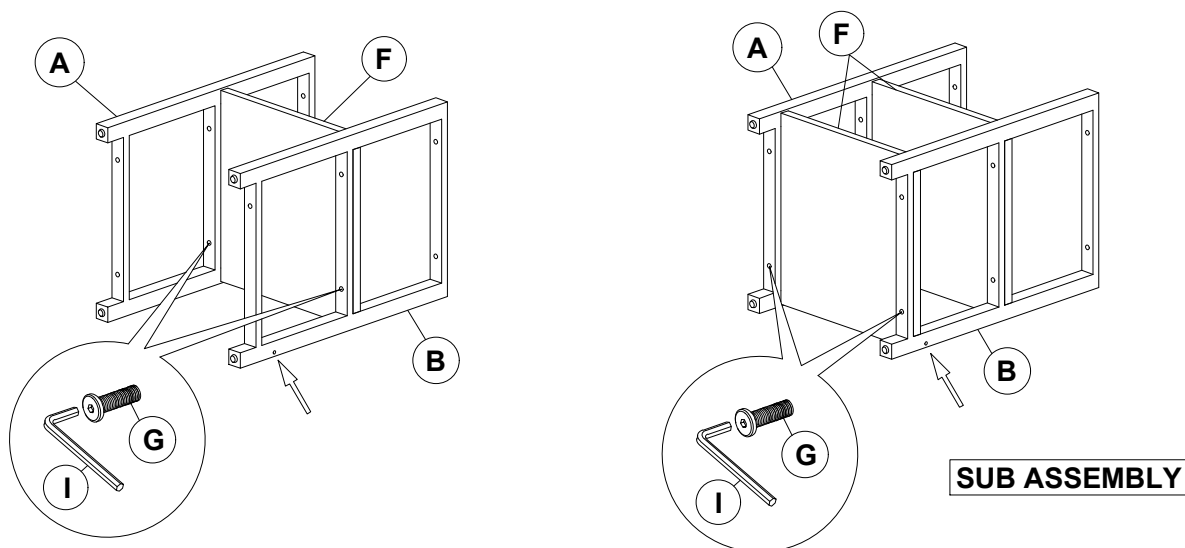

Step 4

Lay Table Top Assembly (E) on a non-abrasive surface. Attach Sub Assembly from Step 3 to Table Top (E) using 4-M6x35MM Hex Bolts (G). Attach Metal Frame (C) to Table Top (E) using 2-M6x35MM Hex Bolts (G) NOTE: DO NOT TIGHTEN ALL BOLTS AT THIS TIME !

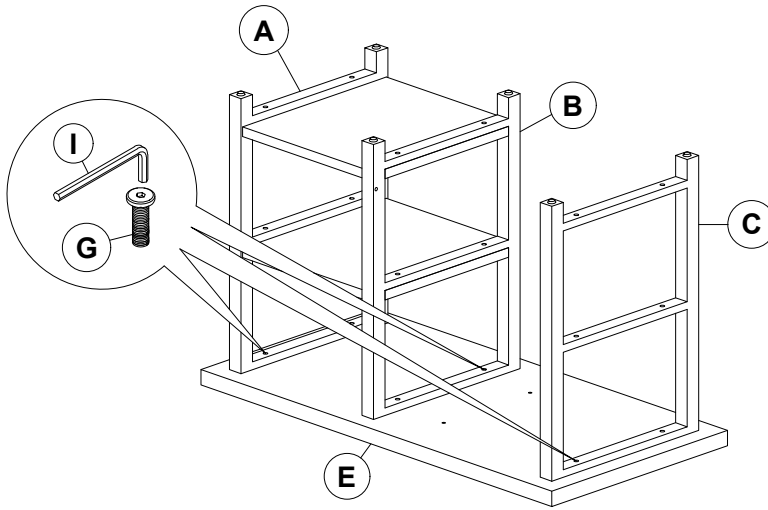

Step

Attach Back Rail (D) to Metal Frame (B) & (C) using 2-M6x20MM Hex Bolts (H) NOTE: TIGHTEN ALL BOLTS AT THIS TIME ! Attach 4-M6x15MM Hex Bolts (J) and Connector Bolts (K) to holes on Metal Frame (C).

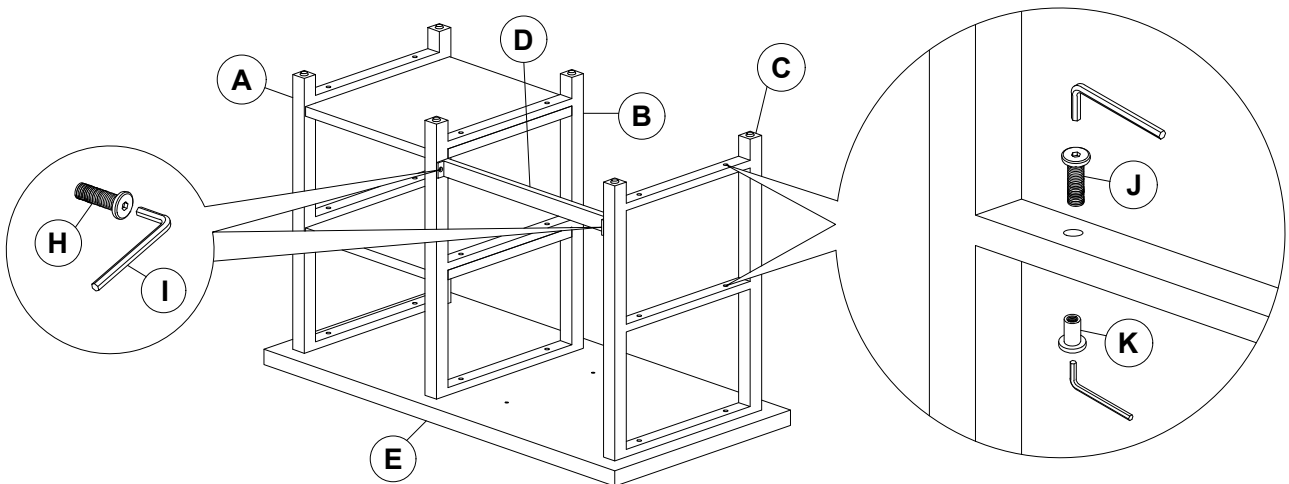

CARE

Clean with a non abrasive cloth using a mild soap. Make sure to wipe dry.

IF YOU WANT SUB ASSEMBLY ON RIGHT HAND

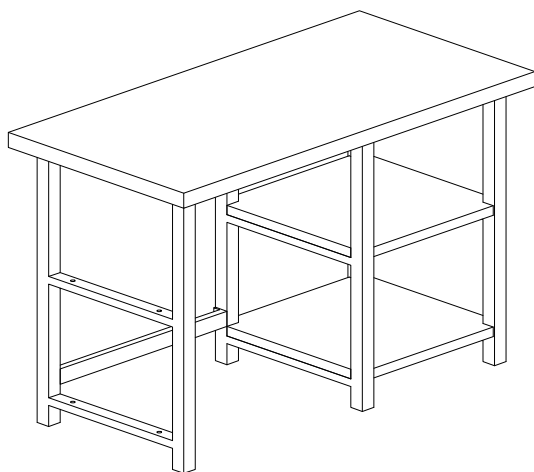

Step 1

Read through these instructions thoroughly before beginning assembly. We have found this to be of great value when assembling this product.

Step 2

Remove all parts and hardware from packing material. Wooden pieces should be placed on a non-abrasive surface to prevent damage to the finish

Step 3

Lay Metal Frame Assembly (A) & (C) on a non-abrasive surface. Attach Shelf (F) to Metal Frame (A) & (C) using 8-M6x35MM Hex Bolts (G). NOTE: DO NOT TIGHTEN ALL BOLTS AT THIS TIME !

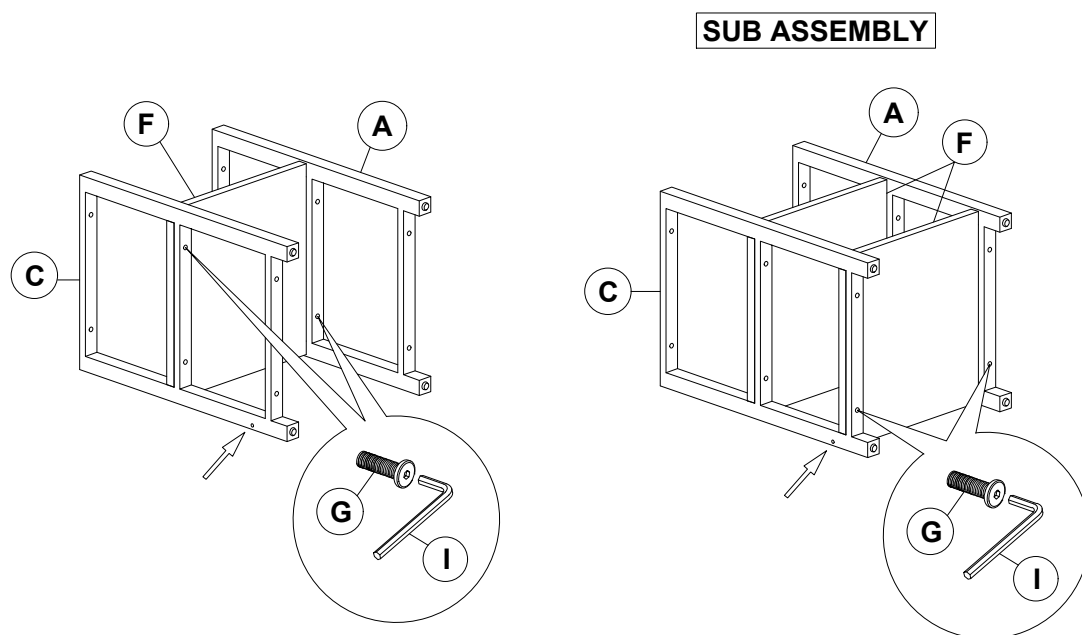

Step 4

Lay Table Top Assembly (E) on a non abrasive surface. Attach Sub Assembly from Step 3 to Table Top (E) using 4-M6x35MM Hex Bolts (G). Attach Metal Frame (B) to Table Top (E) using 2-M6x35MM Hex Bolts (G) NOTE: DO NOT TIGHTEN ALL BOLTS AT THIS TIME !

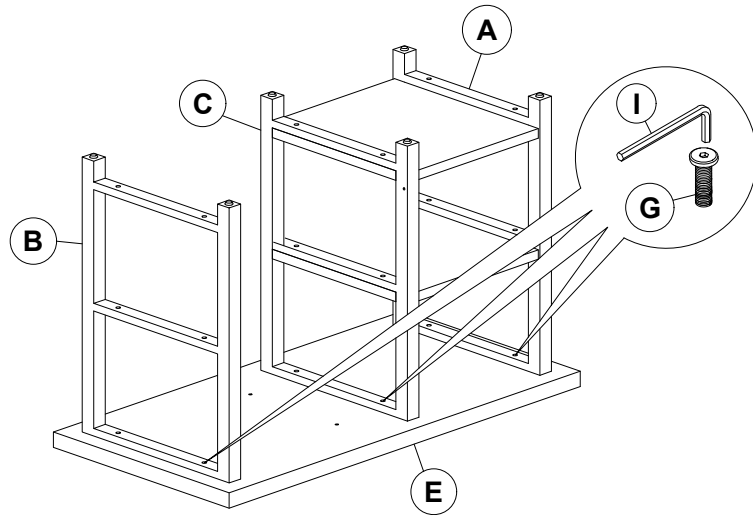

Step 5

Attach Back Rail (D) to Metal Frame (B) & (C) using 2-M6x20MM Hex Bolts (H) NOTE: TIGHTEN ALL BOLTS AT THIS TIME ! Attach 4-M6x15MM Hex Bolts (J) and Connector Bolts (K) to holes on Metal Frame (B).

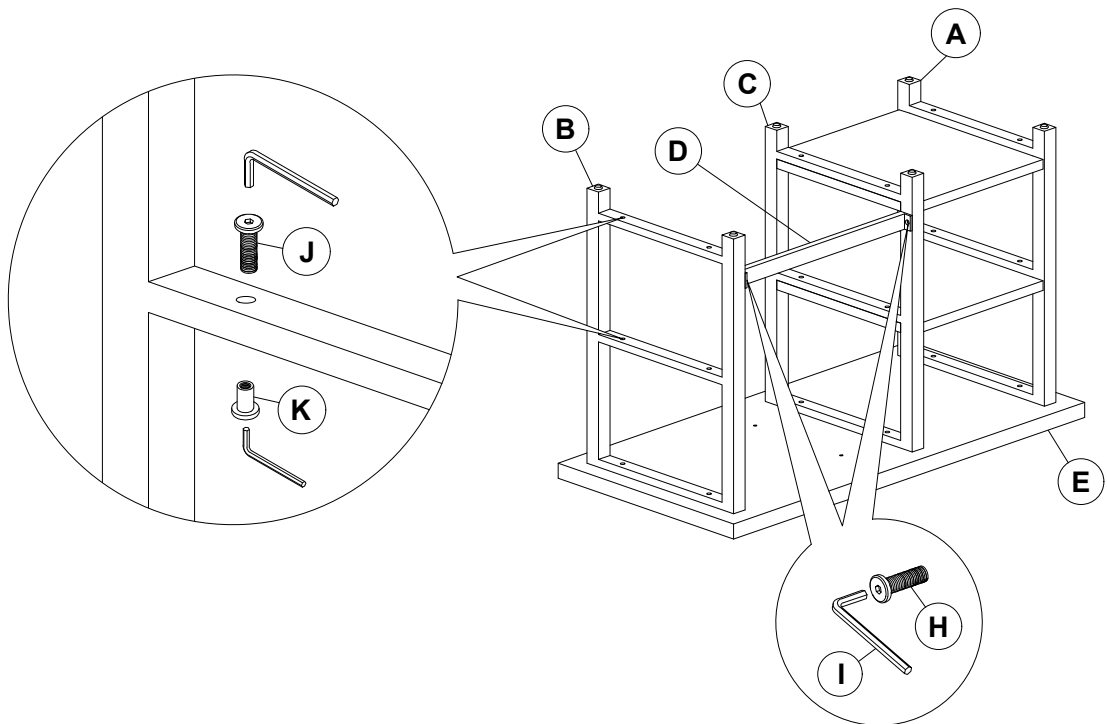

CARE

Clean with a non abrasive cloth using a mild soap. Make sure to wipe dry.
