

Black Electric Dual Motor Desk Frame

SKU: DESK-V103E

Instruction Manual

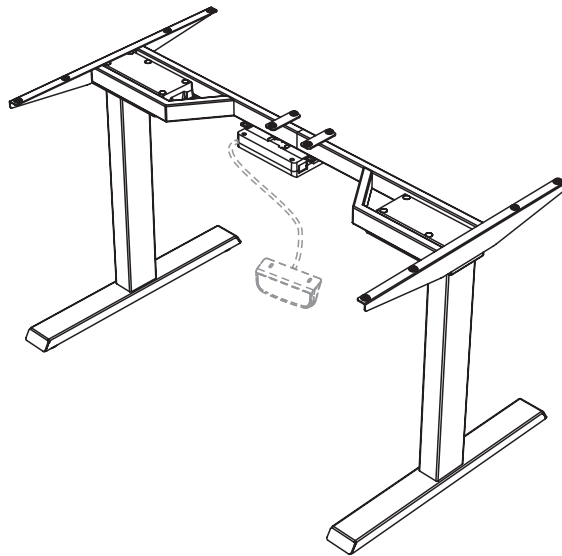

ASSEMBLY VIDEO AVAILABLE:

Follow along step-by-step with our video walk through by scanning the QR code with your mobile device or by following the product link: [vivo-us.com/products/desk-v103e](https://www.vivo-us.com/products/desk-v103e)

Contact Us First!

DO NOT RETURN ITEM

Our friendly product support team is here to help!



PERSONABLE CUSTOMER SUPPORT

7AM - 7PM

Monday-Friday



Give us a Call:
309-278-5303



Chat Us:
www.vivo-us.com



Email Us:
help@vivo-us.com

We're Here for You!

Our customer-minded support team is here for YOU,

Monday-Friday 7am-7pm CST.

We offer immediate assistance with rapid response times from customer service agents and product technicians to help you every step of the way!



Missing a Part?

If any parts are received damaged / defective OR you are missing a part, please reach out to us ***within 30 days of product delivery to have it replaced at no cost.***

We are happy to replace parts to ensure you have a fully functioning product

PRE-ASSEMBLY | BEFORE YOU BEGIN



If you do not understand these directions, or if you have any doubts about the safety of the installation, please call a qualified technician. Check carefully to make sure there are no missing or defective parts. Improper installation may cause damage or serious injury. Do not use this product for any purpose that is not explicitly specified in this manual. Do not exceed weight capacity. We cannot be liable for damage or injury caused by improper mounting, incorrect assembly or inappropriate use.

WARNING: CHOKING HAZARD

SMALL PARTS - NOT FOR CHILDREN UNDER 3 YEARS. ADULT SUPERVISION IS REQUIRED.

TIPOVER WARNING

SERIOUS OR FATAL CRUSHING INJURIES CAN OCCUR FROM TIPOVER. TO HELP PREVENT TIPOVER:

- NEVER ALLOW CHILDREN TO CLIMB, STAND, HANG, OR PLAY ON ANY PART OF TV OR TV CART.
- USE TIPOVER RESTRAINT OR ANCHOR STAND TO WALL

USE OF TIPOVER RESTRAINTS MAY ONLY REDUCE, BUT NOT ELIMINATE RISK OF TIPOVER.

WEIGHT CAPACITY

DO NOT EXCEED WEIGHT CAPACITY. Failure to do so may result in serious injury.



275lbs
(125kg)

PLUGGED IN



176lbs
(80kg)

UNPLUGGED



Product Warranty

For the most up to date details on your product's warranty, please visit the product's listing on our website or reach out to customer support.

vivo-us.com/products/desk-v103e



Returns | Product Didn't Work Out?

We offer a hassle-free 30 day return on all products. Contact customer support at 309-278-5303 or help@vivo-us.com. Please note: For items ordered in error or no longer needed, the return shipping charges will be at the buyer's expense.

TOOLS NEEDED:



Phillips Screwdriver



Drill













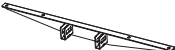



Level

DIFFICULTY LEVEL



PACKAGE CONTENTS

Please consult the parts list below and ensure you have everything you need to assemble your product. If parts are missing or damaged, please contact us.

					
A (x1) Telescopic Crossbar	B (x2) Side Bracket	C (x2) Lifting Column	D (x2) Foot	E (x1) Fixing Plate	F (x1) Control Unit
					
G (x1) Power Cable	H (x1) Control Panel	I (x3) Cable Clip	J (x12) Anti-Vibration Pad		
					
S-A (x8) M6x10mm Screw	S-B (x8) M6x16mm Screw	S-C (x12) 3/4" Screw	S-D (x5) 3/4" Screw	S-E (x2) M4x6mm Screw	T-A (x1) Allen Wrench

NOTE: SOME HARDWARE INCLUDED MAY NOT BE USED

⚠ WARNING

PINCH POINT

DO NOT place hands on or near support bars. Moving parts can crush and cut. Pinch points are created during lifting and lowering the worksurface. Failure to follow these instructions may result in serious personal injury.



ASSEMBLY STEPS

STEP 1: Attaching the Crossbar

Insert Anti-Vibration Pads (**J**) into the mounting holes on top of the Telescopic Crossbar (**A**) and Side Brackets (**B**). Insert the Side Brackets into ends of the Crossbar and place upside down on the desktop.

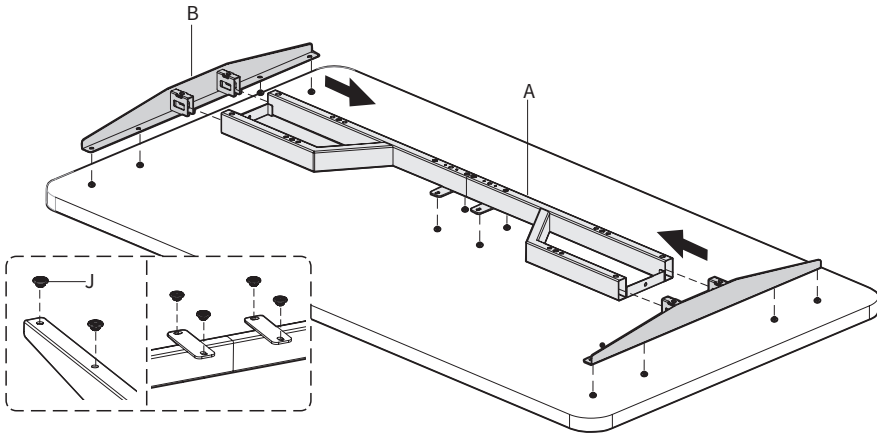

A
Telescopic Crossbar



B
Side Bracket



J
Anti-Vibration Pad



STEP 2: Attaching the Brackets

Place the Lifting Columns (**C**) into the Telescopic Crossbar (**A**) and secure using M6x10mm Screws (**S-A**) and the Allen Wrench (**T-A**). Assemble the Feet (**D**) to the columns using M6x16mm Screws (**S-B**) and the Allen Wrench (**T-A**).

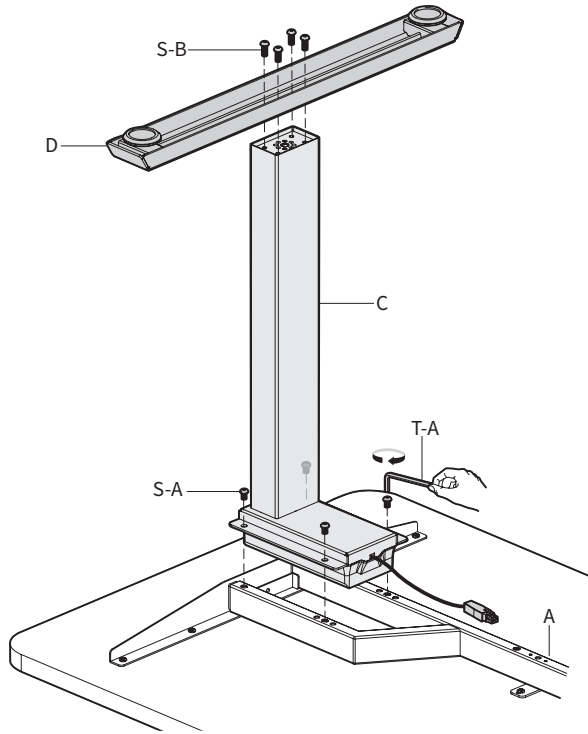

C
Lifting Column



D
Foot



S-A
M6x10mm Screw



S-B
M6x16mm Screw



T-A
Allen Wrench

STEP 3: Installing the Crossbar

Loosen the set screws in the Telescopic Crossbar (**A**) using the Allen Wrench (**T-A**), then extend the Crossbar length to fit the desktop. Retighten the set screws with the Allen Wrench (**T-A**).

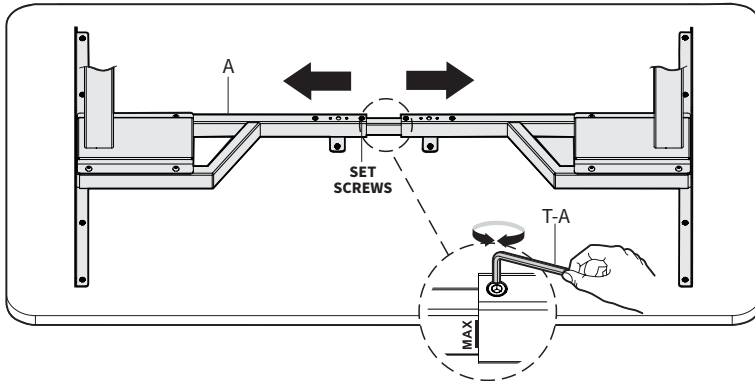

T-A
Allen Wrench

STEP 4: Installing the Frame

Drill $3/8$ " (10mm) deep pilot holes using a $3/32$ " (or 3mm) drill bit. Secure the frame to the desktop using $3/4$ " Screws (**S-C**) with a Phillips screwdriver.

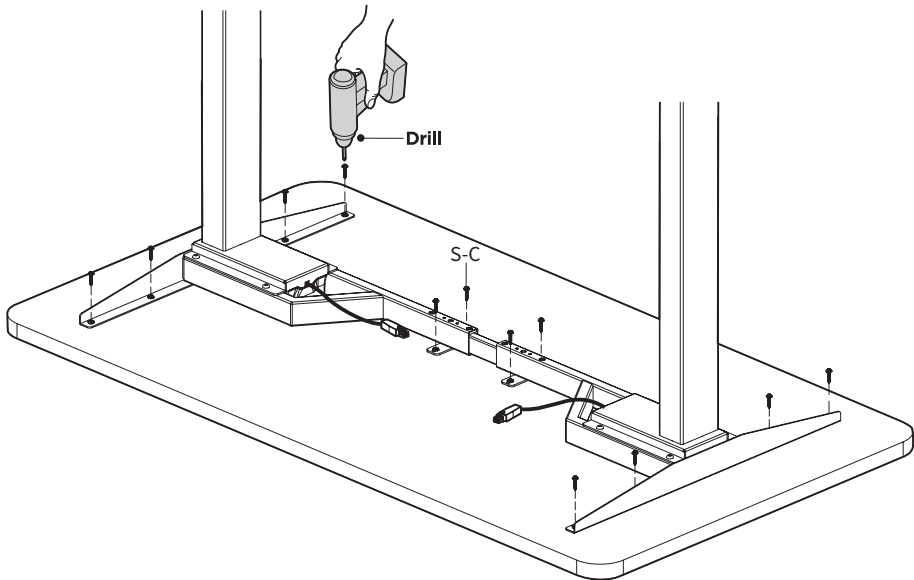

S-C
 $3/4$ " Screw



STEP 5: Install the Control Panel

Place the Control Panel (**H**) at the desired location and mark drilling locations with a pencil. Drill 5/8" (16mm) deep pilot holes under the desktop with a 5/64" (or 2mm) drill bit. Attach the Control Panel (**H**) to the desktop with 3/4" Screws (**S-D**) using a Phillips screwdriver.

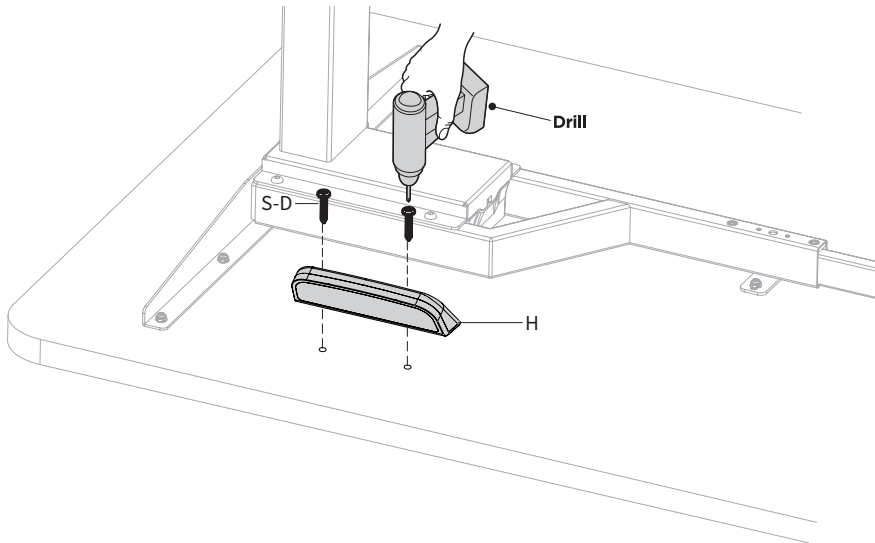

H
Control Panel



S-D
3/4" Screw

STEP 6: Attaching the Fixing Plate

Attach the Fixing Plate (**E**) to the telescopic Crossbar (**A**) using M4x6mm Screws (**S-E**) with a Phillips screwdriver. Slide the Control Unit (**F**) onto the Fixing Plate.

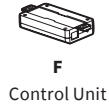
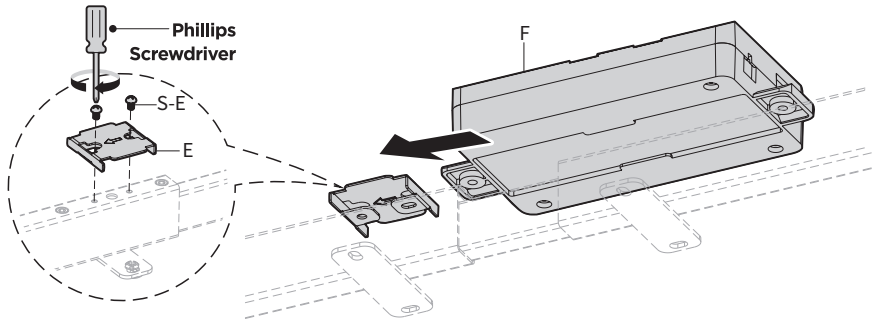

STEP 7: Installing the Cable Clips

Connect motor cables, Control Panel (**H**) and Power Cable (**G**) to the Control Unit (**F**). Determine the locations for the Cable Clips (**I**) and drill 5/8" (16mm) deep pilot holes under the desktop with a 5/64" (or 2mm) drill bit. Mount the clips to the desk using 3/4" Screws (**S-D**) with a Phillips screwdriver, and use the clips to organize the cables.

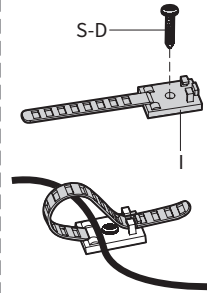
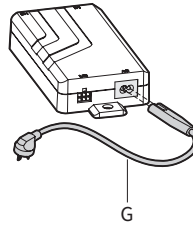
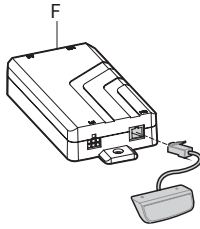
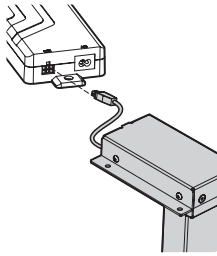
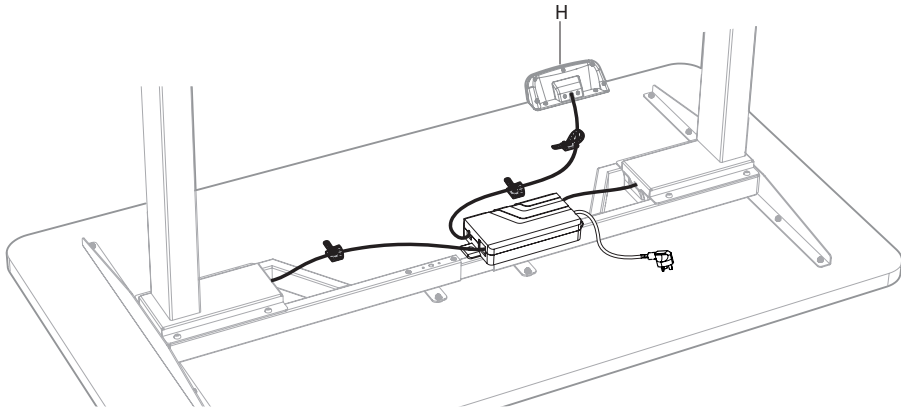

G
Power Cable



I
Cable Clip



S-D
3/4" Screw

STEP 8: Plug In Cable

Connect the Power Cable (**G**) to a wall outlet to power on desk for operation. In the case of uneven floor surface, adjust stabilizing foot pads as needed to make desk level.

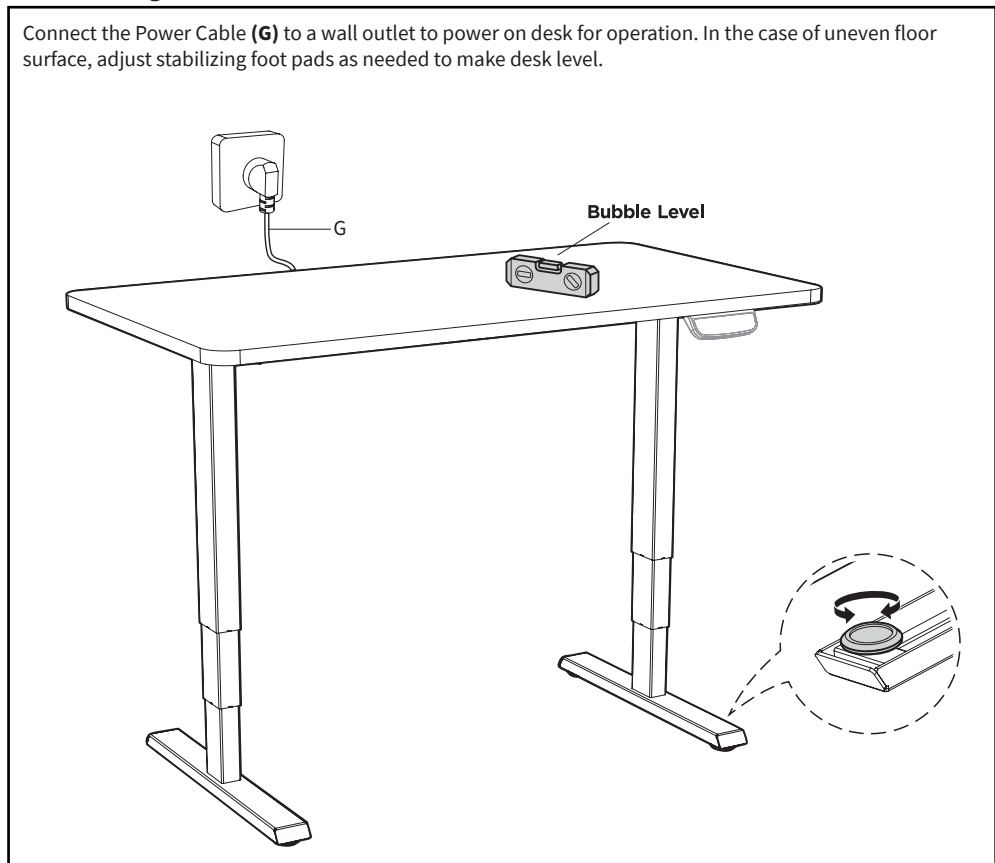

CONTROLLER

OPERATING CONTROL PANEL

When the system is powered on, you will hear a beep and the existing desktop height will be displayed on the control panel.

Sleep Mode

After resting for 10 minutes, the screen will turn off to prevent accidental operation. Touch the screen to exit sleep mode and operate the desk.

Height Adjustment: Press and hold the up or down arrow until the desk reaches the desired height. Press and release the arrow quickly for minor adjustments.

Timer: To set the timer, press “T”. The display will flash “0.5h” representing 30 minutes. Press “T” repeatedly to increase 0.5 hours at a time. The maximum timer setting is 2 hours. The timer is set when the display stops flashing and the light in the top right corner of the controller is on. When the timer has reached the set time, a beep will sound reminding the user to adjust the working position. Once the timer setting has expired (5 beeps), the unit’s timer is canceled. To deactivate the timer, press “T” five times or until the current height is displayed and the light in the upper right corner is turned off.

Memory Setting: To store a certain height in the controller’s memory, first press “M”. The letter “S-” will be displayed. Now press “1”, “2” or “3” within five seconds to store the current height in memory. Each number can store a different height. Once in memory, you can recall any of the three height settings by pressing the corresponding button. Touching any button (except for “T”) will stop the automatic adjustment.

Changing between CM and INCH: The preset measurement shown on the display is cm. If you would like to change cm to inch, then press “T” for at least 3 seconds. The controller will beep twice when changed to inch. Repeat to switch back from inch to cm, and the controller will beep once.

Reset Mode: Press and hold the up and down arrows together until the desk beeps and moves to the fully lowered position (do not release until the process is complete).

TROUBLESHOOTING

E01/E07 Troubleshooting

The system has experienced unusual electrical problems. Disconnect the power first, then wait for 30 seconds (until the display stays off) and reconnect.

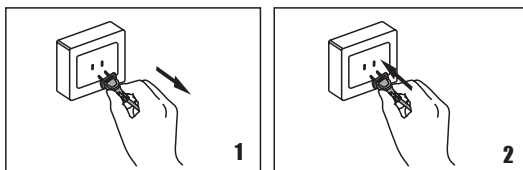

HOT Troubleshooting

The system is overheating. Allow your desk to cool down and remain idle for approximately 18 minutes.

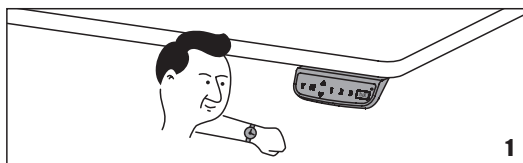

CODE	DESCRIPTION	RESOLUTION
E02	Uneven leg height	Reset the desk
E04	Control panel connection error	Check the connection then reconnect desk power
E05	Collision detected	Release button and clear obstructions
E06	Electrical problem	Replace the control unit
E08	Uneven desktop	Reset the desk and ensure weight is evenly distributed
E11	Motor 1 not connected	Check connection to control unit (M1)
E12/E22	Abnormal electrical current	Replace the control unit
E13	Motor power wire damaged	Replace the motor cable (M1)
E14	Motor sensor wire damaged	Replace the motor cable (M1)
E15	Short circuit in motor 1	Replace the motor (M1)
E16/E26	Motor problem	Reset the desk
E17	Motor 1 running in reverse	Replace the motor cable (M1)
E18/E28	Overload	Remove excess weight from the desk
E21	Motor 2 not connected	Check connection to control unit (M2)
E23	Motor power wire damaged	Replace the motor cable (M2)
E24	Motor sensor wire damaged	Replace the motor cable (M2)
E25	Short circuit in motor 2	Replace the motor (M2)
E27	Motor 2 running in reverse	Replace the motor cable (M2)
E42	Memory function failure	Replace the control unit
E43	Collision sensor failure	Replace the control unit
RSR/RST	Reset failure	Complete reset process to clear error

CUSTOM PROGRAMING

To enter the custom programming menu, press and hold “M” and “T” together for 5 seconds. The controller will beep once and display “S-1”. If no action is taken for more than 10 seconds, the controller will automatically exit the menu. Unsaved settings may be canceled by pressing “T”. The following instructions assume the controller is in the “S-1” state.

Minimum & Maximum Height Settings

To set a minimum height limit

1. Press “M” once, then press the up or down arrow to set your desired min. height.
 2. Press “M” to save. “L-S” will be displayed if successfully saved, or “L-F” shows if failed.
- Note: Default min. height is 62cm (24.4”), and the adjustable range is 62-118cm (24.4”~46.4”).

To set a maximum height limit

1. Press the up or down arrows until “S-2” is displayed.
 2. Press “M” once, then press the up or down arrow to set your desired max. height.
 3. Press “M” to save. “H-S” will be displayed if successfully saved, or “H-F” shows if failed.
- Note: Default max. height is 128cm (50.4”), and the adjustable range is 72-128cm (28.3”~50.4”).

Adjust the Anti-Collision Sensitivity (Current Sensor)

To set collision sensitivity for upward movement:

1. Press the up or down arrows until “S-3” is displayed.
 2. Press “M” once, then press the up or down arrow to change the sensitivity level.
 3. Press “M” to save. “S-S” will be displayed if successfully saved, or “S-F” shows if failed.
- Note: Default sensitivity is 4, and the adjustable range is 0-8. (0: off, 8: maximum)

To set a downwards current sensitivity

1. Press the up or down arrows until “S-4” is displayed.
 2. Press “M” once, then press the up or down arrow to change the sensitivity level.
 3. Press “M” to save. “S-S” will be displayed if successfully saved, or “S-F” shows if failed.
- Note: Default sensitivity is 4, and the adjustable range is 0-8. (0: off, 8: maximum)

To set collision sensitivity for the gyro sensor

1. Press the up or down arrows until “S-5” is displayed.
 2. Press “M” once, then press the up or down arrow to change the sensitivity level.
 3. Press “M” to save. “S-S” will be displayed if successfully saved, or “S-F” shows if failed.
- Note: Default sensitivity is 4, and the adjustable range is 0-8. (0: off, 8: maximum)

Displayed Height with Desktop Thickness

1. Press the up or down arrows until “S-6” is displayed.
2. Press “M” once, then press the up or down arrow to set the desktop thickness.
3. Press “M” to save. “T-S” will be displayed if successfully saved, or “T-F” shows if failed.

Screen Lock Setting

1. Press the up or down arrows until “S-7” is displayed.
2. Press “M” once, then press the up or down arrow to change the screen lock setting. (0: off, 1: on)
3. Press “M” to save. “A-S” will be displayed if successfully saved, or “A-F” shows if failed.

When screen lock is enabled, the display will read “- -” after resting 60 seconds. Press and hold “M” for 3 seconds to unlock. Screen may be locked before 60 seconds by holding “M” again for 3 seconds.

To Save the Customized Settings at one time

After adjusting one setting, press “T” to go back and enter another setting. Once finished, press “M” to save all settings.

To Reset the Customized Settings

Press “M”, “T” and the up arrow simultaneously for 5 seconds. The controller will beep to indicate settings have been successfully reset.

NOTES

- Self-protection function: The unit will enter a protective mode should the system operate in excess of 2 minutes with “HOT” on the controller display. The system will return to normal operation after approximately 18 minutes.
- Over-current protection mode: While operating, should the load on the desk exceed rated specifications, the system will enter into over-current protection mode to protect the system from damage.
- Do NOT remove or reconnect power to reset the unit when in a protective or “HOT” state, as this may damage the electronics.

CHECK OUT OTHER GREAT PRODUCTS FROM



EXPLORE MORE AT VIVO-US.COM

We offer a wide array of home & office products to fit your needs. From height adjustable desks to monitor mounts to keyboard trays and more!

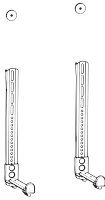

SPEAKER MOUNTS & STANDS

Whether you're mounting a soundbar or surround sound system, we've got a mounting solution to fit your needs

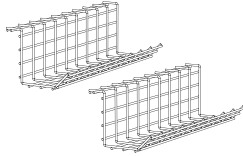

CABLE MANAGEMENT

Clean up tangled work spaces with our sleek cable management solutions!

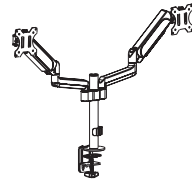

MONITOR MOUNTS

From single monitor mounts to hex mount, grommet or clamp-ons, we've got a mounting solution for your setup.



WHO WE ARE



VIVO is more than a brand of ergonomic office furniture. We are a team of creative and innovative individuals working together to offer high quality, affordable ergonomic solutions. We think and work outside of the box to serve you, our customer, to the best of our ability.



Need Assistance?

We Would Love to Help!



Personable Customer Support | **Mon-Fri 7am-7pm**

We offer immediate assistance with rapid response times from customer service agents and product technicians to help you every step of the way!



Call Us: **309-278-5303**

Average Resolution Time: **5m 4s**



Chat Us: **www.vivo-us.com**

Average Resolution Time: **< 15m**



Email Us: **help@vivo-us.com**

Average Resolution Time: **1HR 8M**

23% within < 15m

38% within < 30m

61% within < 1hr

83% within < 2hr

92% within < 3hr



LOVE YOUR NEW VIVO SETUP?

Ready to share that new amazing setup? Want to brag about that amazing new ergonomic solution?

Tag us in your photo!



VIVO-us @vivo_us

FOR MORE GREAT VIVO PRODUCTS,
CHECK OUT OUR WEBSITE AT: WWW.VIVO-US.COM