

# **INTERIOR DOOR ASSEMBLY GUIDE**

# INCLUDED

If you are missing any parts please contact us before moving forward

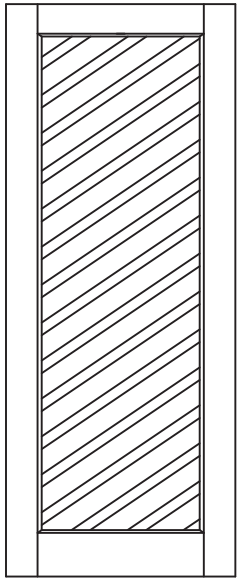

**\*Your Ordered Door**  
(this door image is an example)

## You will need



**(1) \*Strike Side Jamb**



**(1) \*Hinge Side Jamb**

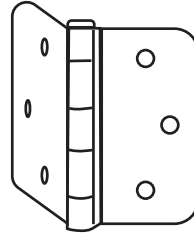

**(3) Door Hinges**  
**(4) Door Hinges for 8'0" doors**

← Hinge cut-outs with pre-drilled screw holes.

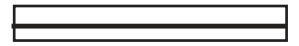

**(6) Torx Head 1-3/4" Assembly Screws**



**(18) x 3/4" Hinge Screws**  
**(24) x 3/4" Wood Screws for 8'0" Door**

\*Components vary between 8'0" and 6'8" door sizes

## YOU WILL NEED...

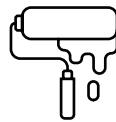

### MDF Door Orders:

Your door comes with primer on it, this is not a finished white paint, please finish door with paint after the door has been assembled and installed.



Two people



Gloves



Drill



Safety Glasses/  
Goggles



#2 Phillips &  
T-20 Torx Head Bits 2

# PHASE 1

## 1. To begin the assembly:

- A. Lay down protective material to protect the finish of your door during assembly.  
This can include cardboard pieces or packing material from the shipping crate.
- B. Ensure your door is lying on a flat, level and elevated surface like a table or sawhorse.

## 2. Place the hinge side jamb next to the hinge side of the door. Line up the hinge cut-outs side by side.

\*you may also choose to use a sawhorse as a way to elevate the door.

## 3. Once alignment is checked, carefully move the door to the edge of the table or work station (along with protective material between the door and table) to prepare installing the hinges (image 1).

## 4. Attach the hinges to the door first. Once one side is attached, use a second person to position the jamb to match the cut-out hinge spots to the second half of the hinge. Once in position screw in the second half of the hinge (image 2).

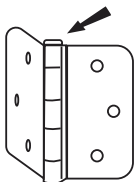

Install hinges with nail head towards top of door.

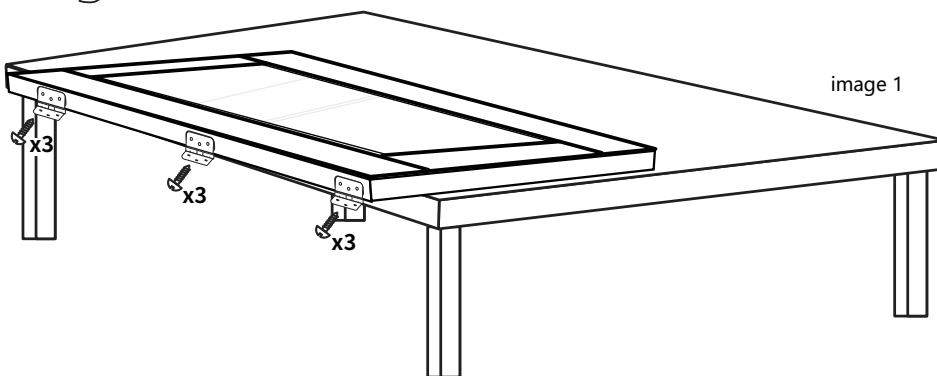
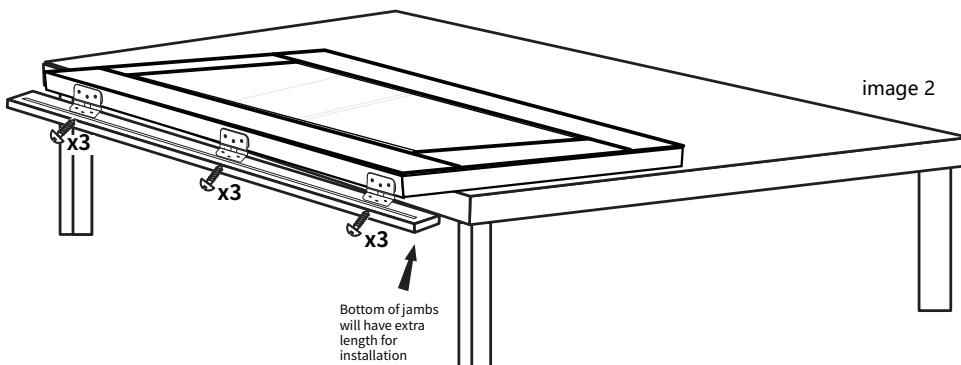
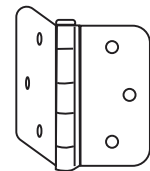

image 1



Bottom of jambs will have extra length for installation

## You will need:



3 Hinges



3/4" Hinge Screws



Two people

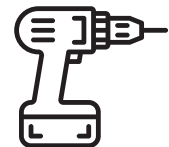

Drill

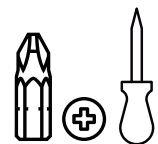

#2 Phillips & T-20 Torx Head Bits



Safety Glasses/  
Goggles

# PHASE 2

5. Attach the header to the hinge side jamb using the supplied Torx head assembly screws and pre-drilled holes, which are located on the outside of the jambs. Header and jamb should line up at a 90 degree angle (image 3). Then attach the strike side jamb to the other side of the header (image 4).

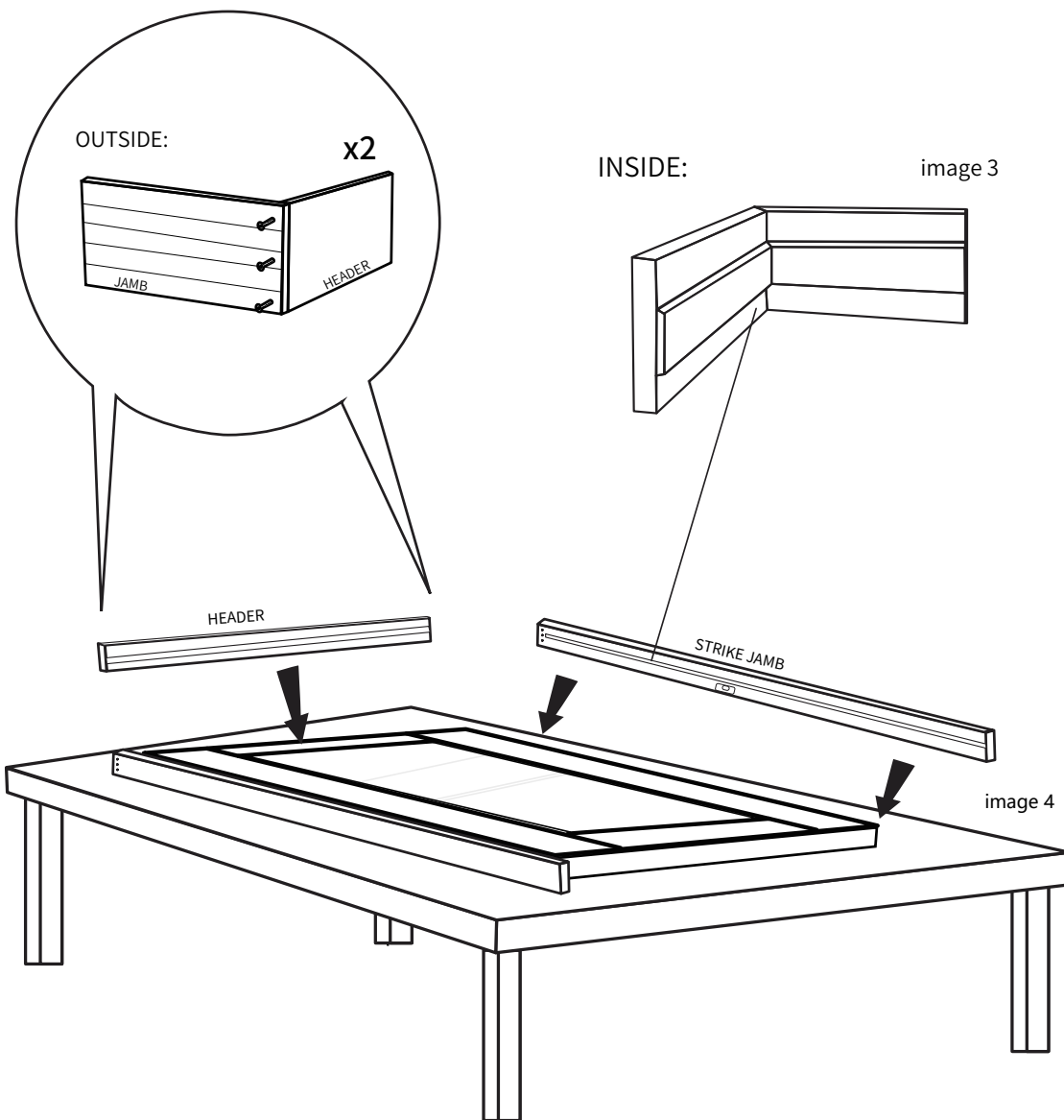

## You will need:

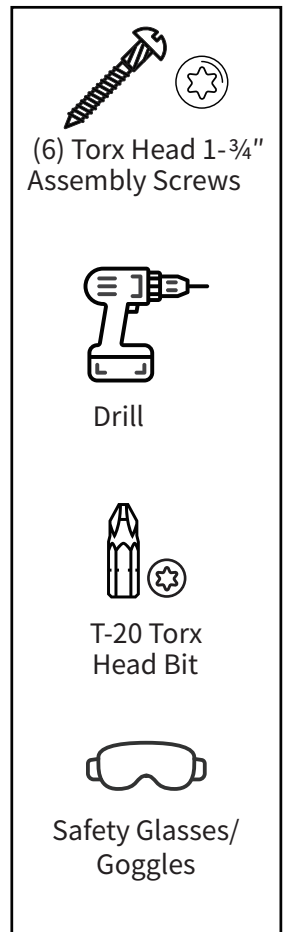

6. Your door is assembled! For assistance with installation, please contact our customer support team.