

# Installation & Assembly

## HEADBOARD SET ASSEMBLY INSTRUCTION (TOTAL 1 BOX)

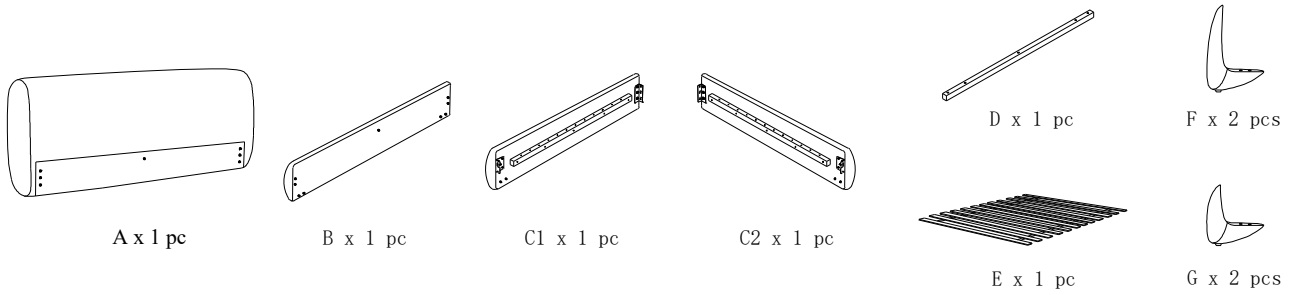

Please read over the instructions, it will be a time-saver in the long run.

Note: Before assembly, please be sure to work on a soft flat surface to avoid any damage to the finish.

Please leave bolts loosened until all bolts are placed before tightening completely.

Part#	Picture	Description	QTY	Location	Part#	Picture	Description	QTY	Location
H		Center leg	3	Wrapped in a non-woven bag	Q		Spring Washer Ø8	12	Hardware Pack
I		Triangle connection piece	2	Wrapped in a non-woven bag	R		Flat Washer Ø8x25mm	14	Already in Place
J		Cp3-1	2	Wrapped in a non-woven bag	S		Flat Washer Ø8x22mm	4	Hardware Pack
K		Bolt Ø6x30mm	6	Already in Place	T		Flat Washer Ø8x18mm	8	Hardware Pack
L		Bolt Ø8x30mm	14	Already in Place	U		Spring Washer Ø6	6	Already in Place
			2	Hardware Pack	V		Flat Washer Ø6x25mm	6	Already in Place
M		Bolt Ø8x60mm	8	Hardware Pack	W		Spanner Ø14	1	Hardware Pack
N		"L" Wrenches Ø4	1	Hardware Pack	X		Screws 4x30mm	36	Hardware Pack
O		"L" Wrenches Ø5	1	Hardware Pack					
P		Nut Ø8	2	Hardware Pack					

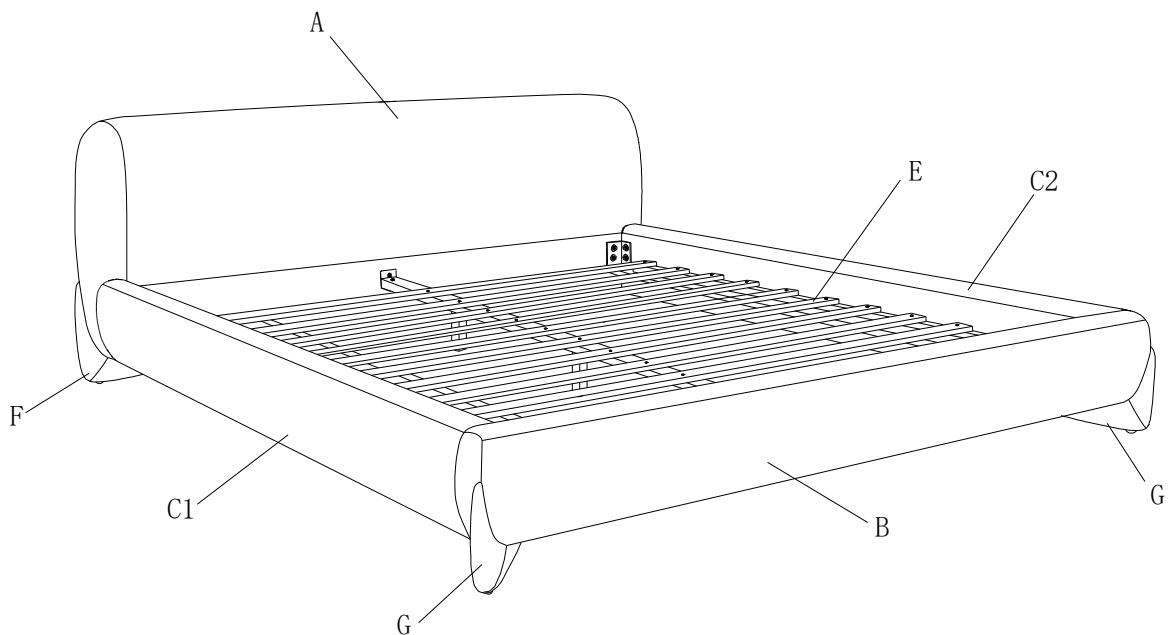

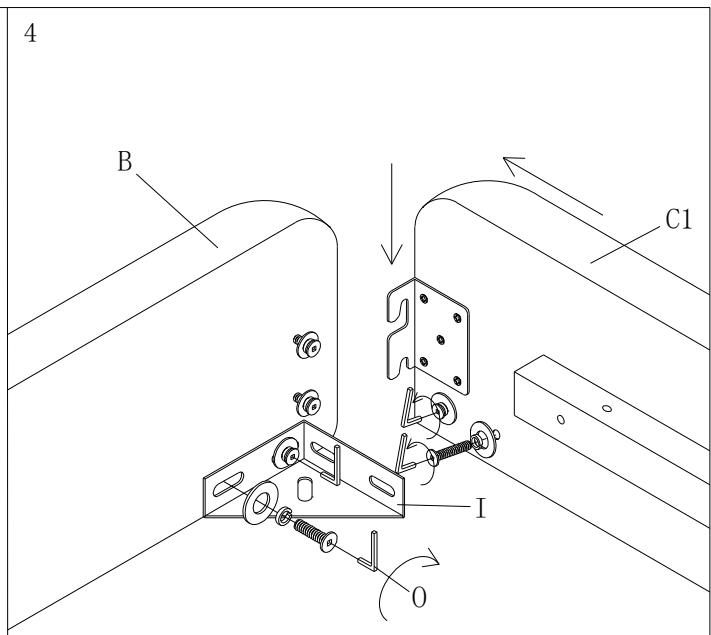
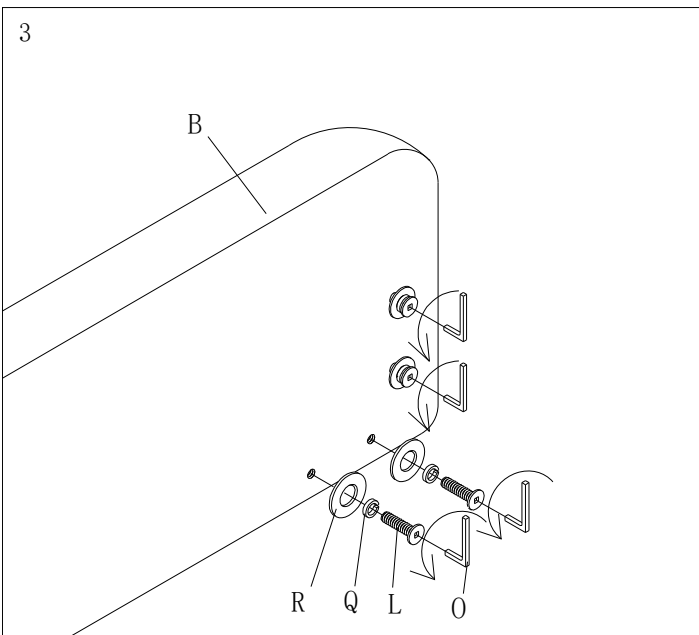
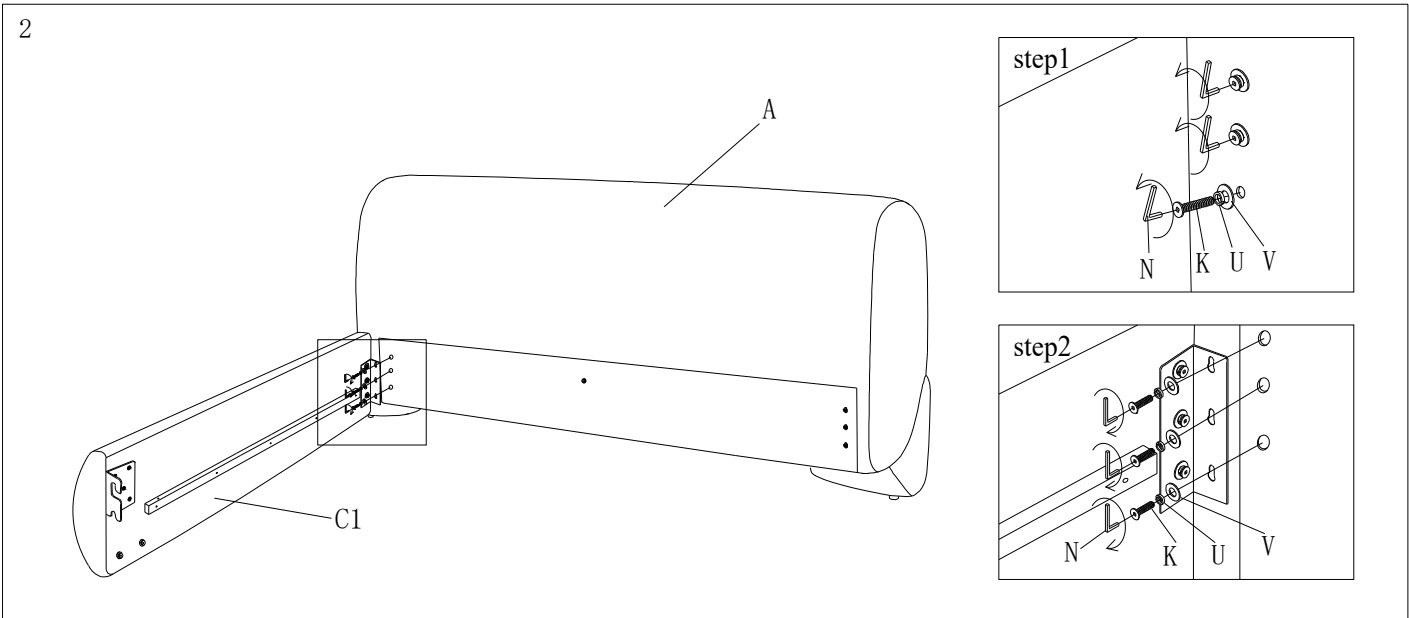
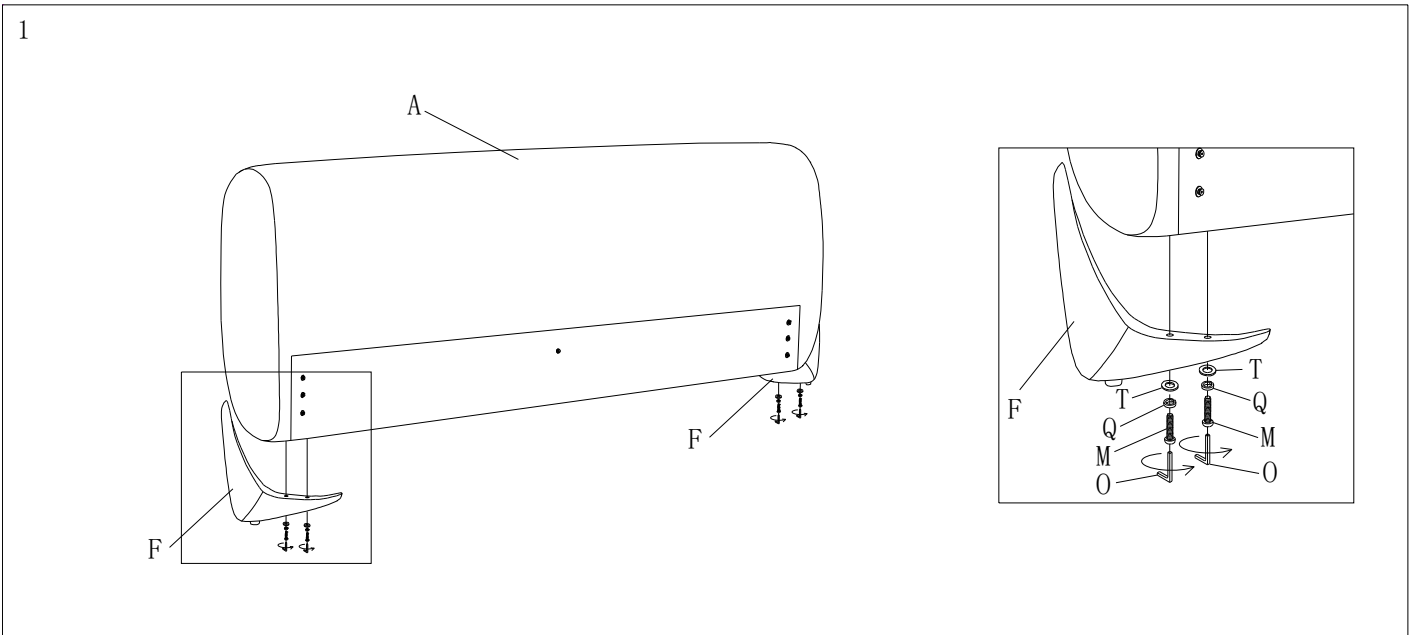

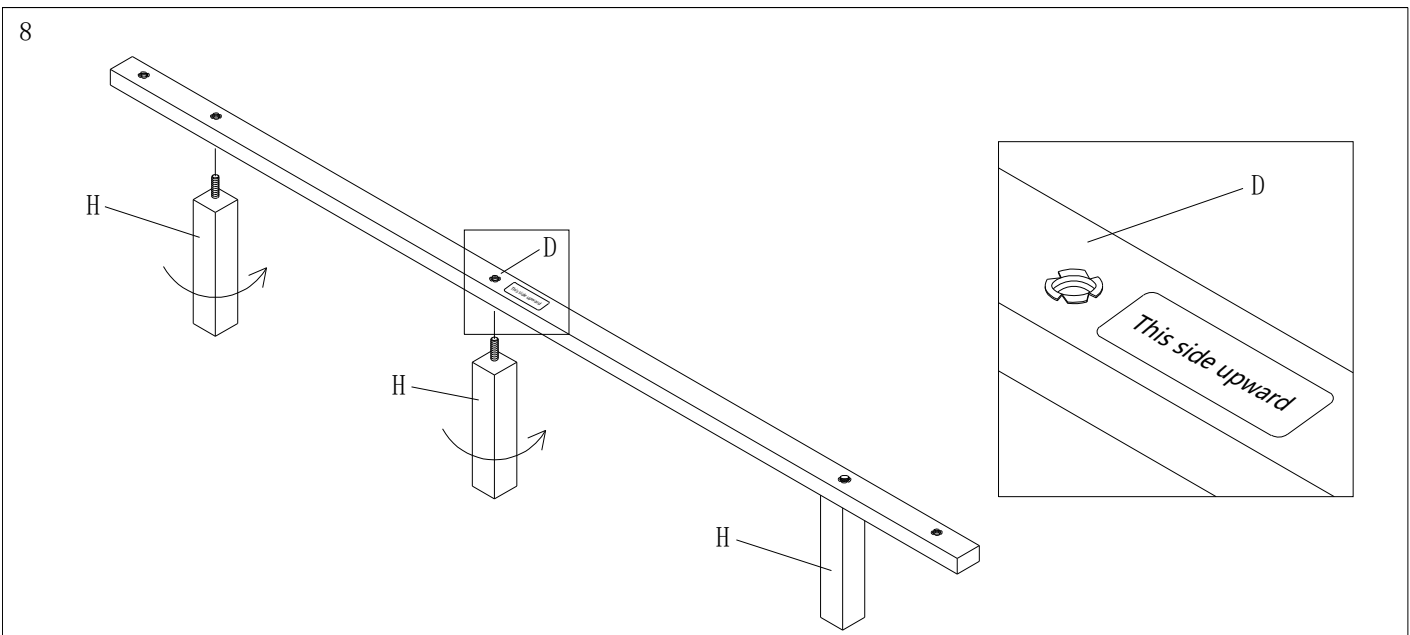
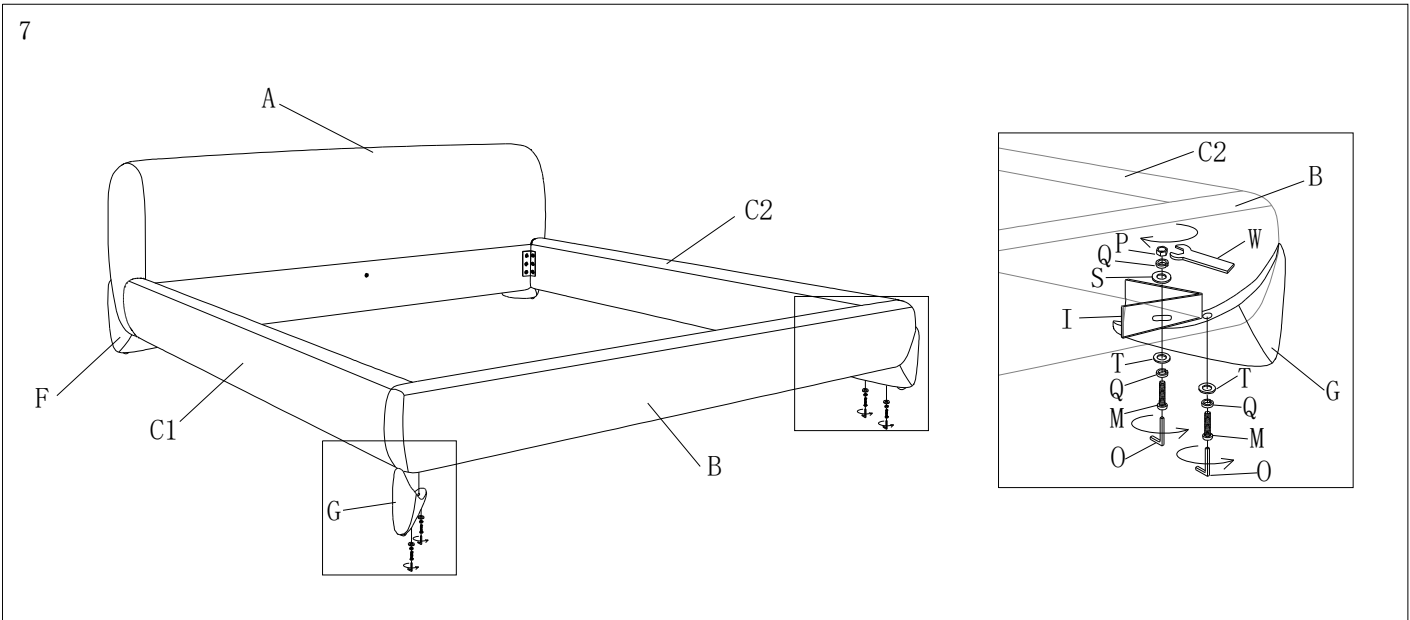
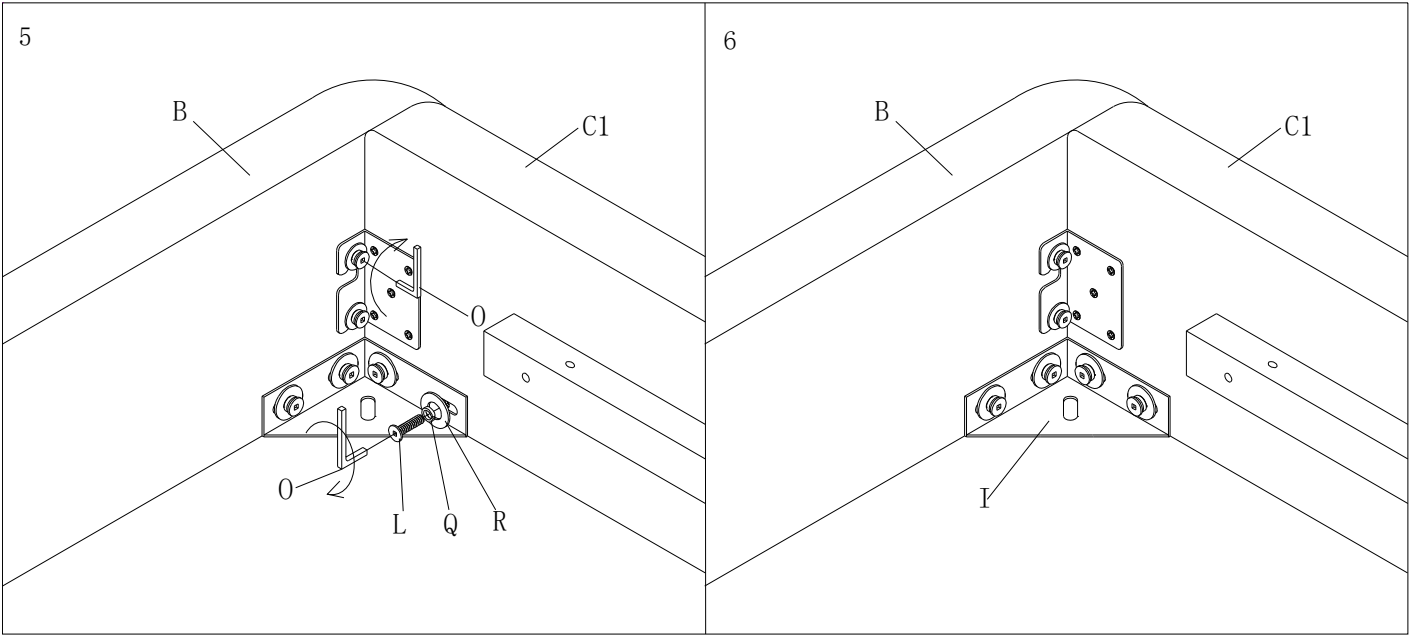

9

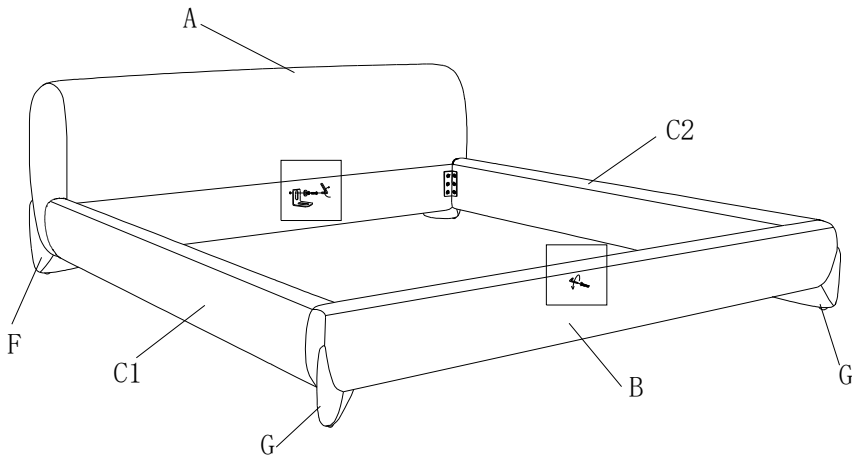

step1

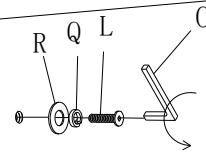

step2

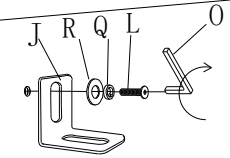

10

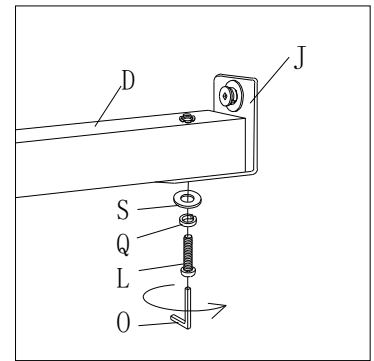
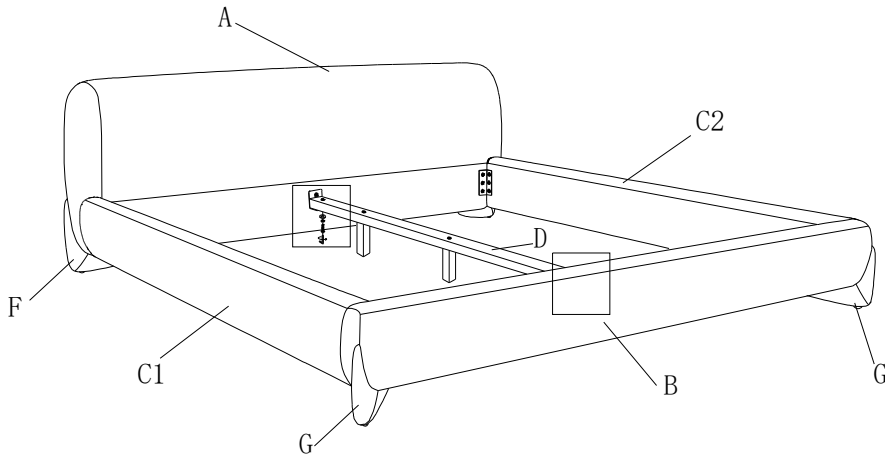

11

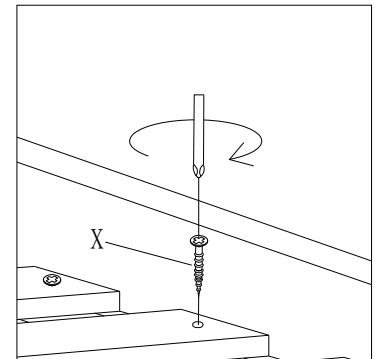
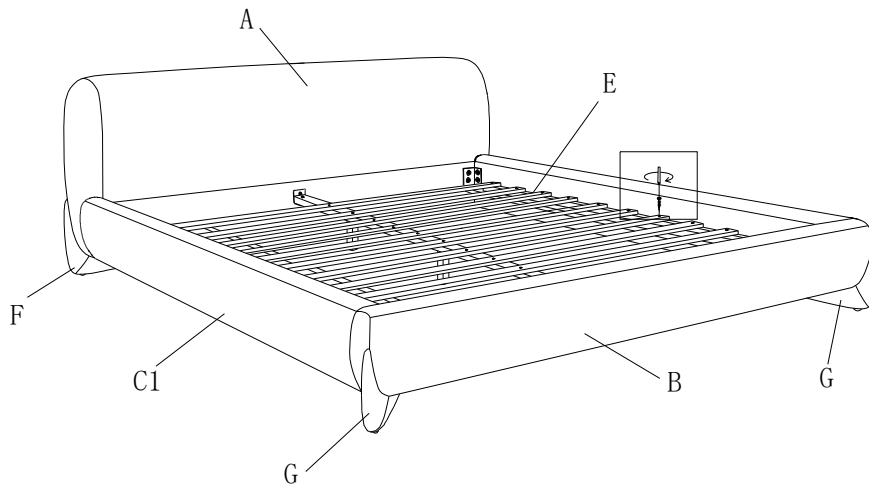

Screwdriver required, not included