

SALON CHAIRS
USER MANUAL

SALON CHAIRS



This is the original instruction, please read all manual instructions carefully before operating. We reserves a clear interpretation of our user manual. The appearance of the product shall be subject to the product you received. Please forgive us that we won't inform you again if there are any technology or software updates on our product.

Safety precautions

WARNING:

Read this instructions before using this product. Failure to do so can result in serious injury. the basic precautions should always be followed,including the following:

1. The reptile incubator may not be used or stored in hazardous areas. It is not allowed to use the appliance in hazardous locations.
2. The reptile incubator must be checked to ensure that it is in proper working order and is operating safely prior to use. Otherwise,the appliance must not be used.
3. Use as intended only. The reptile incubator is not suitable for sweeping off corrosive substances. as they can harm the materials on the snow pusher.
4. The operator must use the reptile incubator properly. He must consider the local conditions and must pay attention to third parties,in particular children,when working with the reptile incubator.
5. This reptile incubator is not intended for use by persons (including children) with reduced physical,sensory or mental abilities or lacking experience and/or knowledge,unless they are super- vised by a person responsible for their safety or are instructed by these persons on the use of the device. Children should be supervised,to ensure that they do not play with the reptile incubator.

SAVE THESE INSTRUCTIONS

Product List

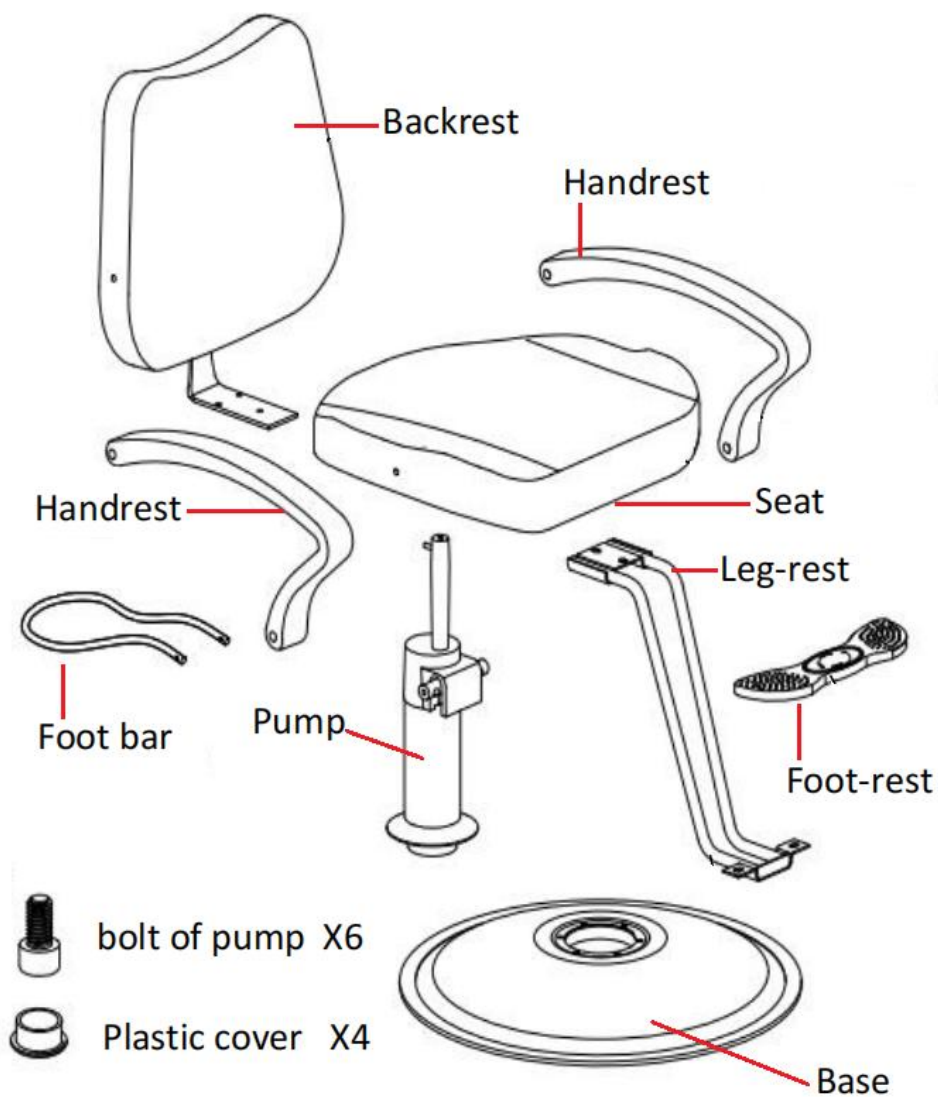

Product Assembly

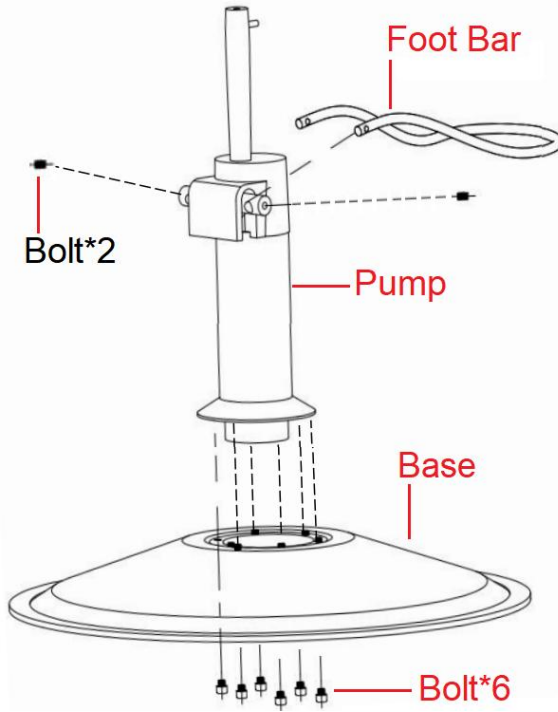

1

(May require slightly squeezing ends of Foot Bar towards each other, and some maneuvering for the bar ends to go into place.)

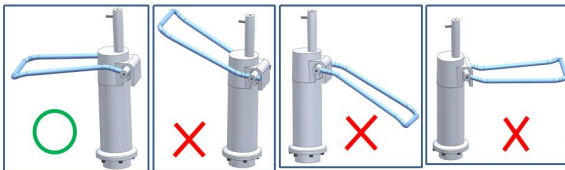

Insert threaded bolts on bottom of Pump into holes on top of Base. Tighten 6 locking nuts onto threaded bolts. (Easiest when set on side, supported by a sturdy object.)

Place assembled Base & Pump on floor. Use Allen Wrench to loosen the screws in the crossbar. See photo besides. Insert Foot Bar into the holes of the crossbar.

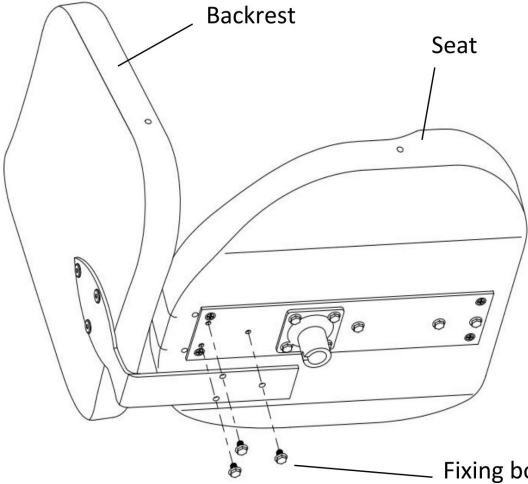
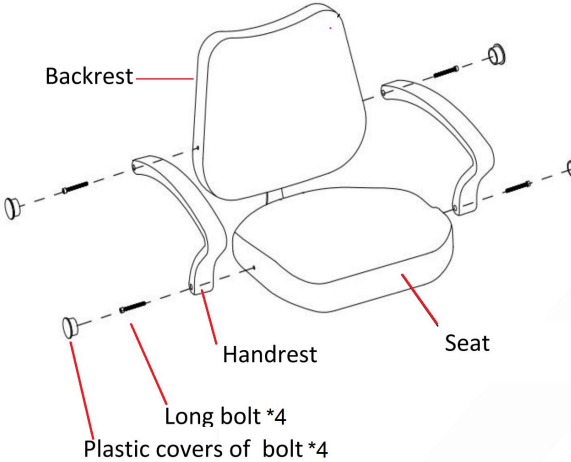
| | | |
|---|--|---|
| 2 |  | <p>Remove the 3 fixing bolts which Pre-fixed on the seat cushion.</p> |
| | | <p>Install backrest to the seat cushion by the 3 fixing bolts which given from the seat cushion.</p> |
| 3 |  | <p>Remove 4 long bolts Which pre-fixed on the back rest and seat cushion.</p> |
| | | <p>Install 2 handrest to The seat cushion & backrest By the 4 long bolts which given from seat cushion and backrest</p> |
| | | <p>Install 4 plastic covers of bolt to the 2 handrests.</p> |

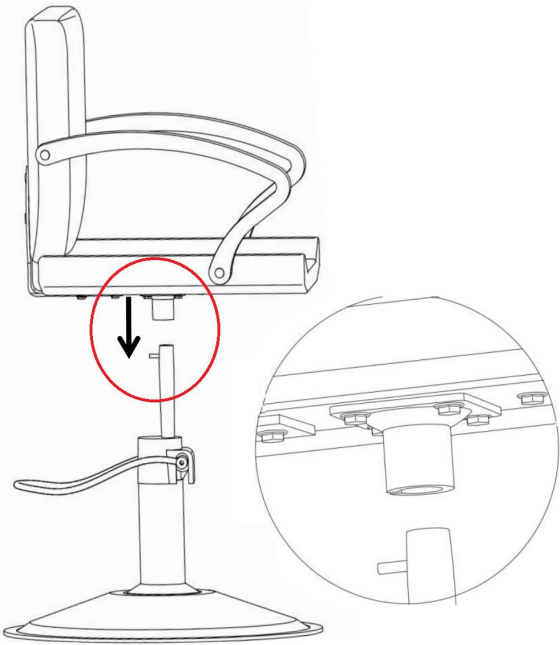
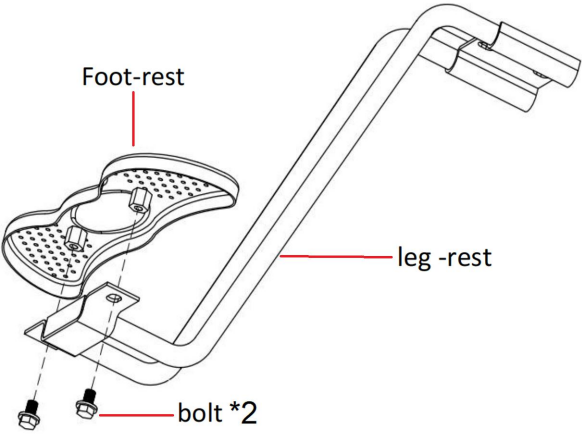
| | | |
|----------|--|---|
| <p>4</p> |  | <p>Place the installed Seat on to the hydraulic pump (please note the pin on the pump toward the gap of the pump joint).</p> |
| <p>5</p> |  | <p>Remove 2 bolts which pre-fixed in the footrest.</p> <p>Install the leg-rest to The leg-rest by the 2 removed bolts and tighten them.</p> |

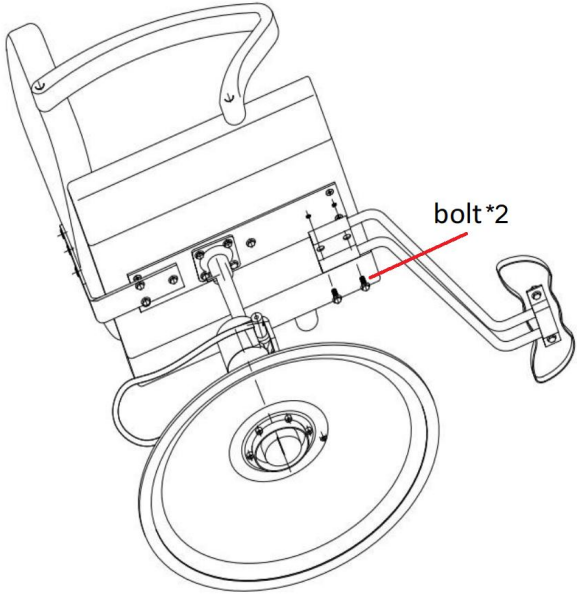
| | | |
|----------|---|--|
| <p>6</p> |  | <p>Remove 2 bolts Which pre-fixed in the seat.</p> <p>Install the installed footrest to the seat by the 2 given bolts and tighten them .</p> |
|----------|---|--|

Product Use

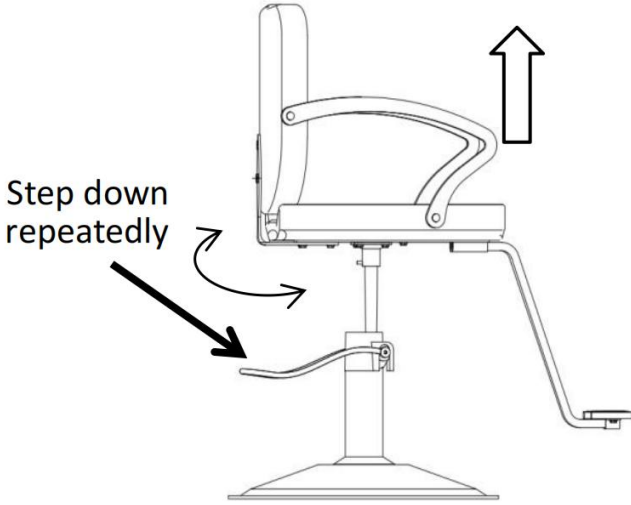
| | |
|---|---|
|  <p>Step down repeatedly</p> | <p>Step down on the Foot Bar repeatedly to raise the chair.</p> |
|---|---|

Step down
and hold

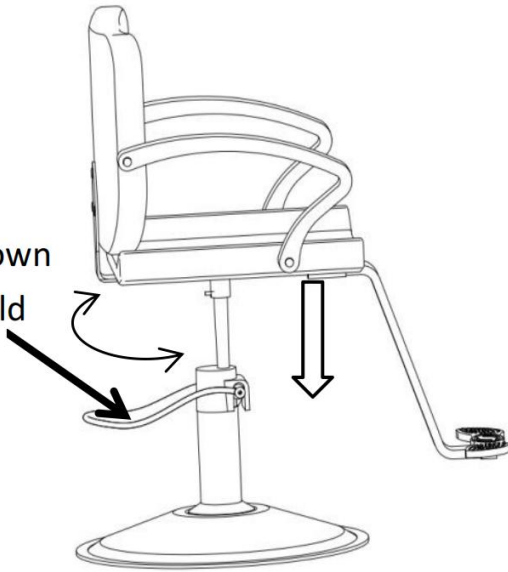

Step down and hold
the Foot Bar to
allow chair to lower.

Hold up

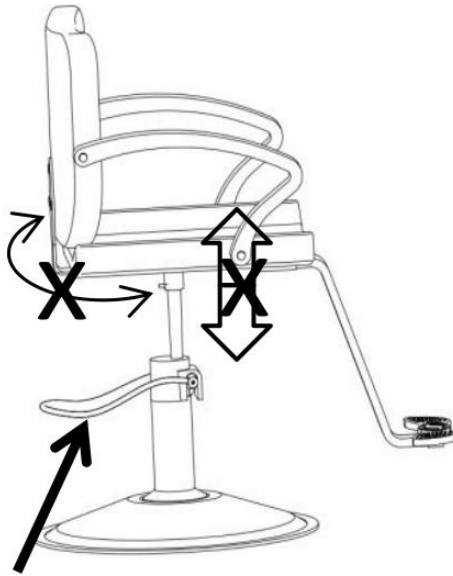

Hold the Foot Bar
up to keep the chair
still.

Do not over-extend
the chair, creating
the risk of falls or
tipping the chair and
its occupant
over, resulting in
injury.