

# ASSEMBLY INSTRUCTIONS

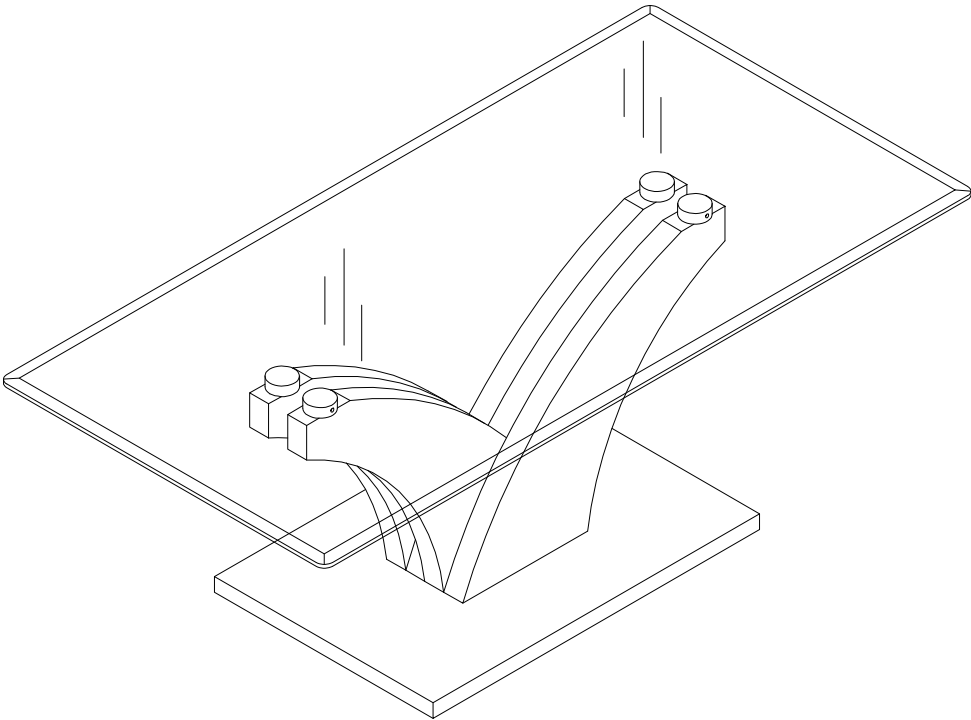

## TOOLS REQUIRED



Allen Wrench  
(Included)

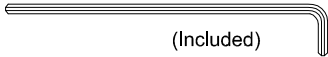

Allen Wrench  
(Included)



2 - People  
Recommended

## ASSEMBLY RATING



EASY —————> DIFFICULT

The Assembly Rating is a 5-point system showing the level of effort needed to assemble a specific product.



## **CHECK BEFORE STARTING**

- Are you missing anything?**  
Double-check all parts, hardware and accessories listed are all accounted for.
- Check out our Quick Tips!**  
We recommend reviewing the pre-assembly handouts. Even experts need a refresher now and then!
- Should we send any replacements?**  
Are there any irregularities or flaws in the parts? We can send replacements!
- Prep Time!**  
Please review the assembly instructions and all diagrams prior to assembling.

# PRE ASSEMBLY INTRODUCTION

We understand building ready-to-assemble furniture can be a challenging experience for some. To help avoid confusion, we have provided some helpful tips that may speed up the process.

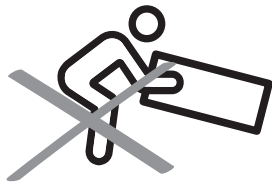

## Teamwork

ALWAYS have at least two people to help with transporting and assembling the product to avoid potential injury and/or damage.

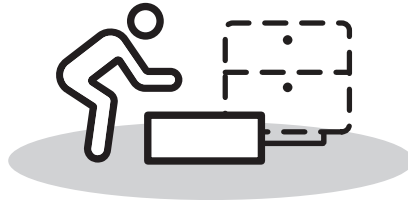
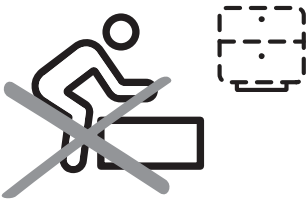

## Suitable Location

Assembling near the area of the intended location is highly recommended.



## Sufficient Space

Make sure you have enough space to move around during the assembly.



## Avoid Scratches

Use cardboard, blankets or a carpeted area while assembling furniture to prevent to prevent scratches and damages.

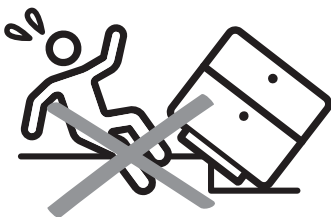

## Flat Surface

Make sure the furniture rests on a flat and level surface with each leg evenly touching the floor.

# ASSEMBLY AND CARE ADVICE



**FAILURE TO FOLLOW THE GUIDELINES BELOW MAY RESULT IN INJURY AND/OR PROPERTY DAMAGE.**



Position each part correctly and insert screws or bolts into their respective holes.

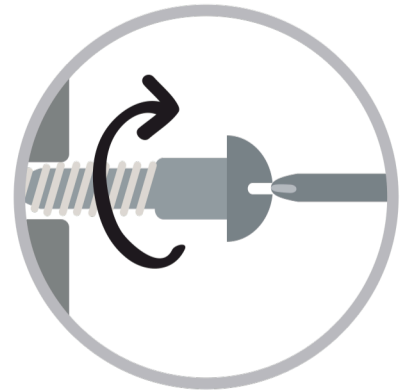

Turn clockwise to tighten and only tighten when step is completed or when instructed to do so.



Use the appropriate hand tools or power tools for assembly. Select steps, such as tightening screws and/or bolts, may require hand tools to avoid causing damage during assembly.



Save the instructions and store any supplied tools for later maintenance.

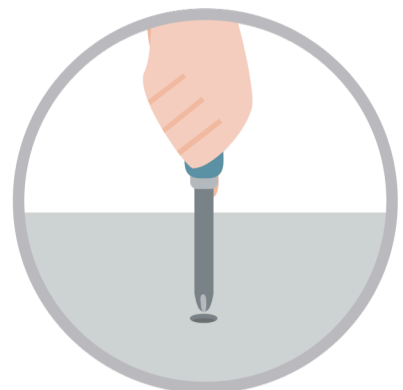

After two weeks, check and tighten any loose hardware and repeat again every six months thereafter.

**IT IS THE USER'S RESPONSIBILITY TO MAINTAIN THE FURNITURE. THE HARDWARE MAY LOOSEN OVER TIME AND MAY CAUSE THE FURNITURE TO BE WOBBLY AND UNABLE TO SUPPORT ITS INTENDED WEIGHT CAPACITY. THIS MAY LEAD TO COLLAPSE AND MAY CAUSE SERIOUS INJURY.**

# COFFEE TABLE



- Please keep instructions for future reference.
- Check the quantity and irregularity of parts and hardware before you start.

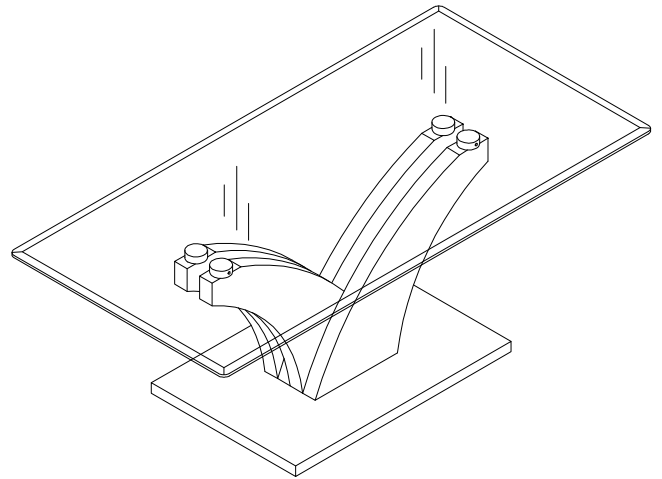

## PARTS

#1 1pc

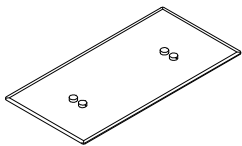

Glass Top

#2 2pcs



Right Support Leg

#3 2pcs



Left Support Leg

#4 1pc

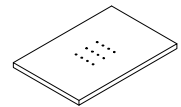

Bottom

## HARDWARE

#A 8pcs



Bolt 1/4" X 1-3/4"

#B 6pcs



Adjustable Foot

#C 4pcs



Set Screw 1/4" X 3/8"

#D 8pcs



Washer

#E 1pc

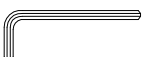

Allen Wrench M4

#F 1pc



Allen Wrench M3

#G 4pcs



Wood Dowel Ø8 X 30

# ASSEMBLY INSTRUCTIONS

## 1

Insert 4 wood dowels (#G) to the holes in the center of the bottom panel (#4)

Part #4 x1pc  
Hardware #G x 4pcs

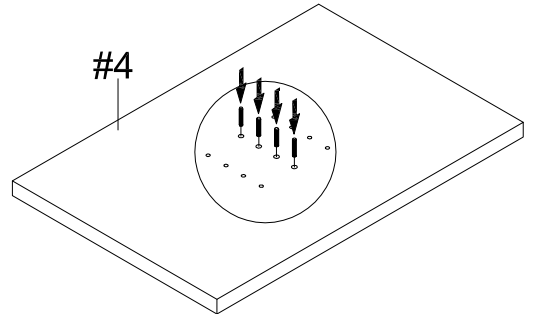
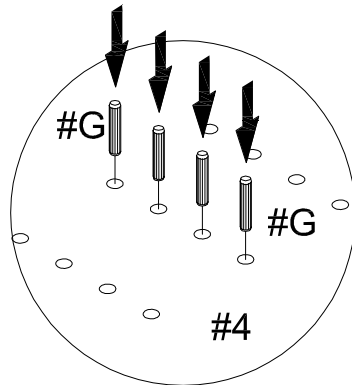

## 2

Part #2 x 2pcs  
Part #3 x 2pcs  
Hardware #A x 8pcs  
Hardware #B x 6pcs  
Hardware #D x 8pcs

1) Attach support legs (#2,3) to the bottom panel (#4). Make sure the legs are attached through the wood dowels.

Two people recommended for this step

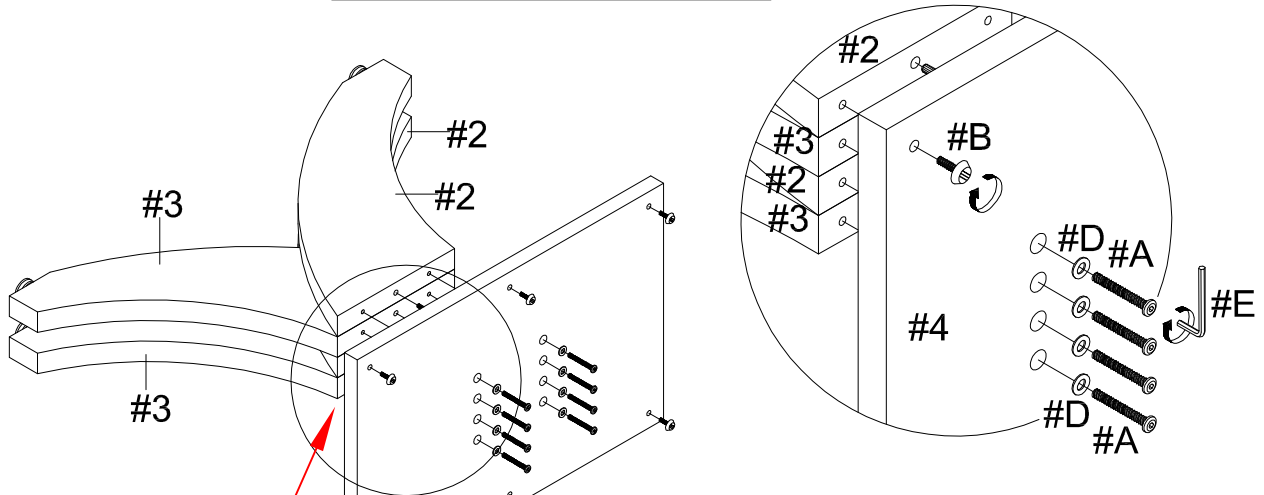

Note: Place a support underneath Part #2 and Part #3 to avoid legs from being suspended in midair.

2) Prepare 8 bolts assembly by inserting flat washer (#D) to bolts (#A). Secure panel to legs with bolts (#A). Attach adjustable foot (#B) to the bottom panel (#4) as shown in the picture.

# ASSEMBLY INSTRUCTIONS

## 3

1) Carefully place the top glass (#1) onto the legs.

Part (#1) x1pc

Hardware (#C) x4pcs

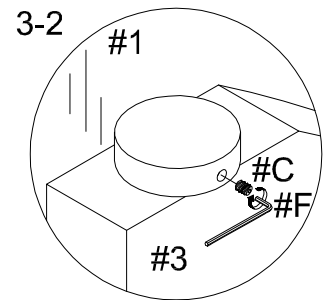
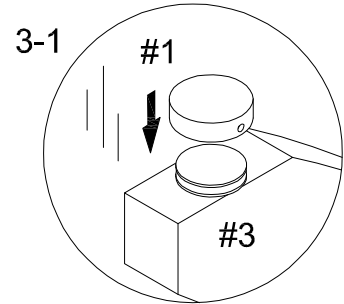
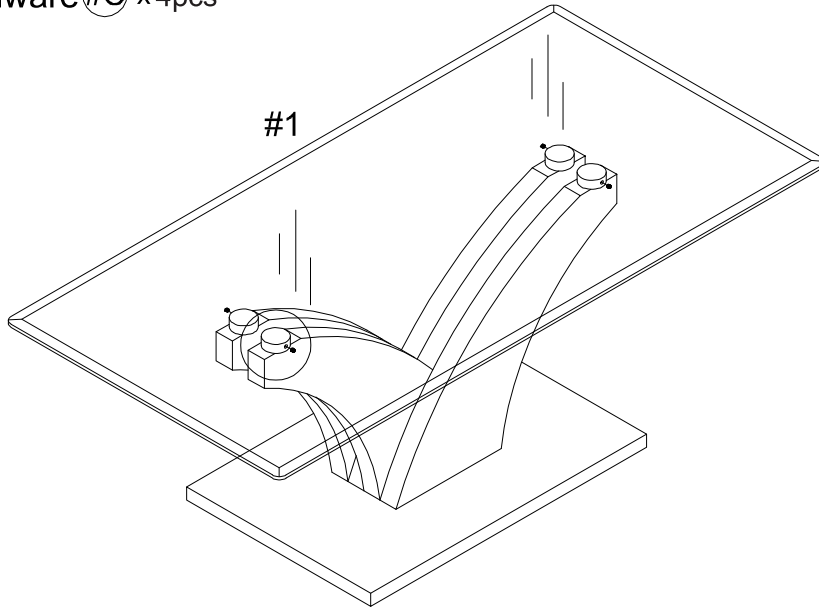

Secure with set screws (#C) to ensure safety of the glass

## 4

Make sure every bolts are secured tightly.

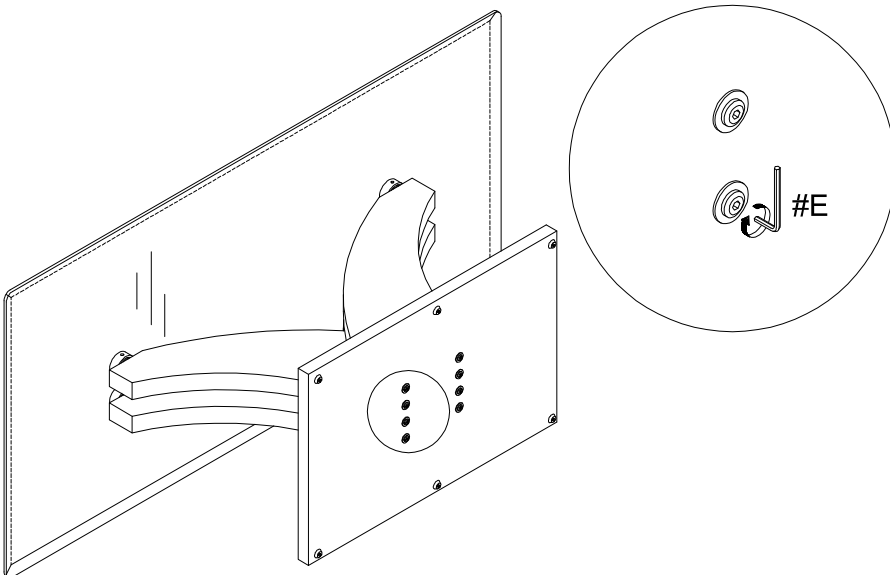

### ASSEMBLY COMPLETED



Please ensure the furniture rests on an even and flat surface. If the product wobbles or feels loose, double-check all bolts and/or screws are properly tightened and secured.



#### Keep this handy!

Please retain this instruction manual and any order-related information for future reference.



#### Lift, don't drag!

To avoid damage to product please always LIFT the product when transporting or adjusting the placement.