









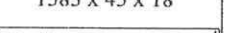

ASSEMBLY INSTRUCTIONS

QUEEN STORAGE BED



(Box 1) BOX OF HEADBOARD

No	ITEM	Qty
A	Headboard 	1 pc
B	Headboard Left & Right 	2 pcs
B.1	Headboard Leg Support 1583 x 45 x 18 	1 pc

(Box 2) BOX OF FOOTBOARD

No	ITEM	Qty
C	Footboard 	1 pc
D	Slat 1545 x 45 x 18 	9 pcs
E	Center Slat - L1500 x 45 x 18 	1 pc
F	Slat Support - L320 x 30 x 30 	2 pcs
G	Trundle Drawer Front Panel 	2 pcs
H	Trundle Drawer Side Panel 	4 pcs
I	Trundle Drawer Back Panel 	2 pcs



(Box 2) BOX OF FOOTBOARD

No	ITEM	Qty
J	Trundle Drawer Bottom Panel 	2 pcs
K	Trundle Drawer Bottom Support with custer wheel 	4 pcs
L	Trundle Drawer Bottom Support without custer wheel 	4 pcs

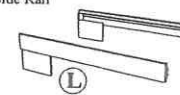



(Box 3) BOX OF FOOTBOARD

No	ITEM	Qty
M	Side Rail 	2 pcs



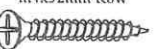
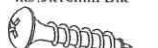

(Box 1) HARDWARE LIST

No	ITEM	Qty
1	JCBC M6 x 35mm 	8 pcs
2	SPRING WASHER 1/4" Rbw 	8 pcs
3	Flat Washer 1/4"ID x 19mmOD Blk 	8 pcs
4	ALLEN KEY m4x65mm Blk 	1 pc
4.1	Flat Head Chipboard Screw m4x32mm Rbw 	2 pcs

(Box 2) HARDWARE LIST

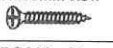
No	ITEM	Qty
5	K1536 D34mmxH22mm Handle Antique Brass 	4 pcs
6	Handle Screw m4x35mm Blk 	4 pcs
7	Flat Head Chipboard Screw m4x32mm Rbw 	24 pcs
8	Pan Head Chipboard Screw m3.5x16mm Blk 	12 pcs
9	Wood Dowel 6mmx30mm 	16 pcs

(Box 2) HARDWARE LIST

No	ITEM	Qty
10	Flat Head Chipboard Screw m4x32mm Rbw 	18 pcs
11	JCBC M6 x 50mm 	2 pcs
12	ALLEN KEY m4x65mm Blk 	1 pc
13	ALLEN KEY m5x65mm Blk 	1 pc

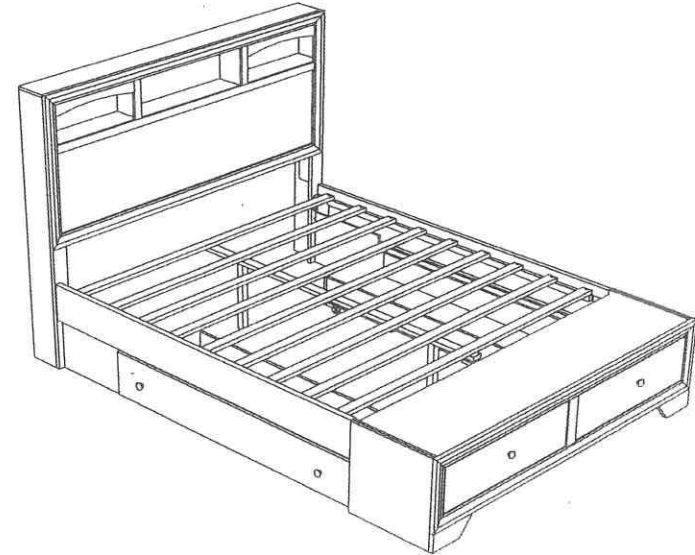

NOTE : DURING ASSEMBLY, DO NOT TIGHTEN ANY HARDWARE UNTIL THE COMPLETE UNIT HAS BEEN ASSEMBLED.

ASSEMBLY INSTRUCTIONS

STEP 1 : Attached and tighten the Headboard Leg L/R (B) to the Headboard (A).Insert Spring Washer (2) Flat Washer (3),use JCBC Bolt (1) to fix with Allen Key (4). Fix the Headboard support Leg (B.1) and tighten with screw (4.1) accordingly as shown.

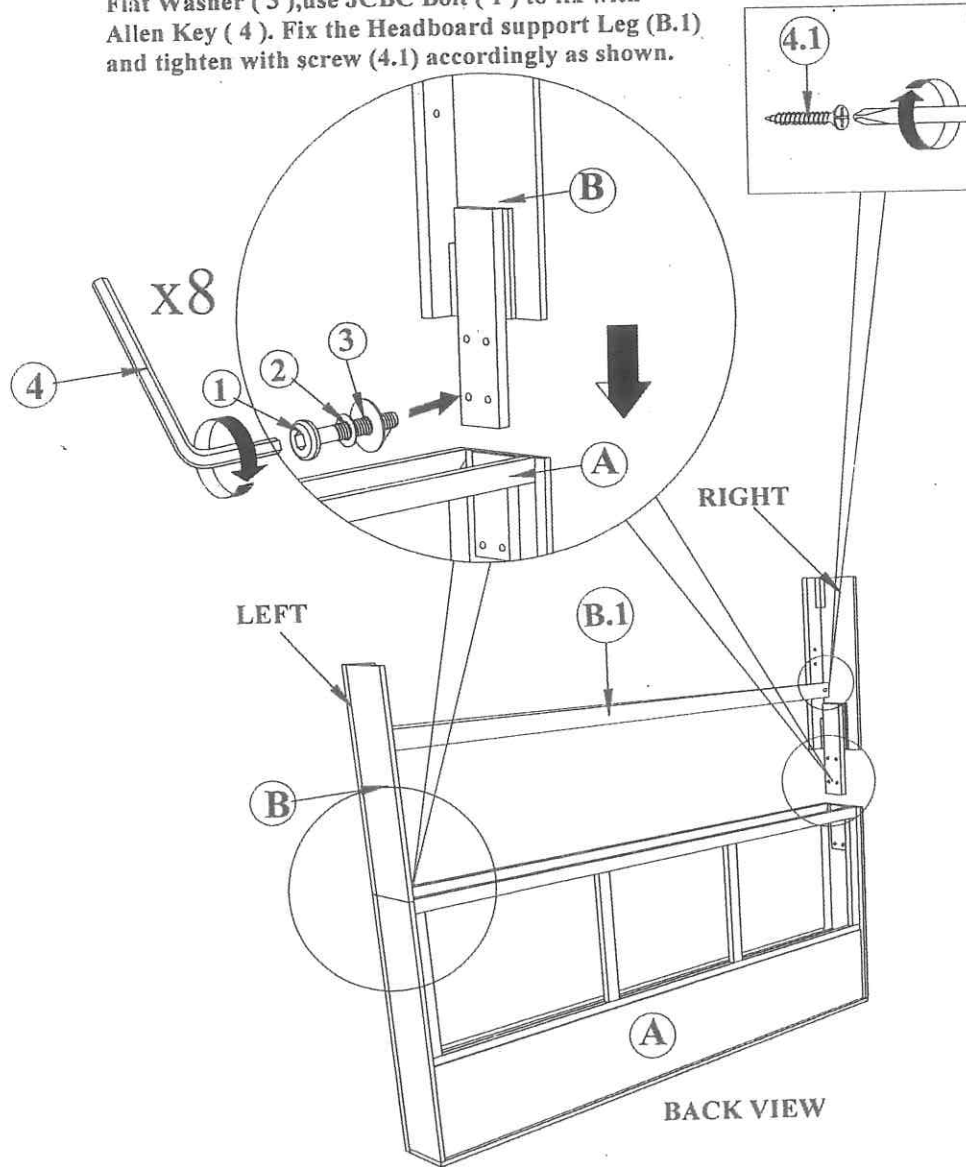

STEP 2 : Loosen the JCBB Bolt from Headboard Leg (B) and Footboard (C) using ALLEN KEY (13).Attach the Side Rail (M) to Headboard Leg (B) and Footboard (C) by pushing the bracket down to fit it.Tighten the JCBB Bolt with ALLEN KEY (13).

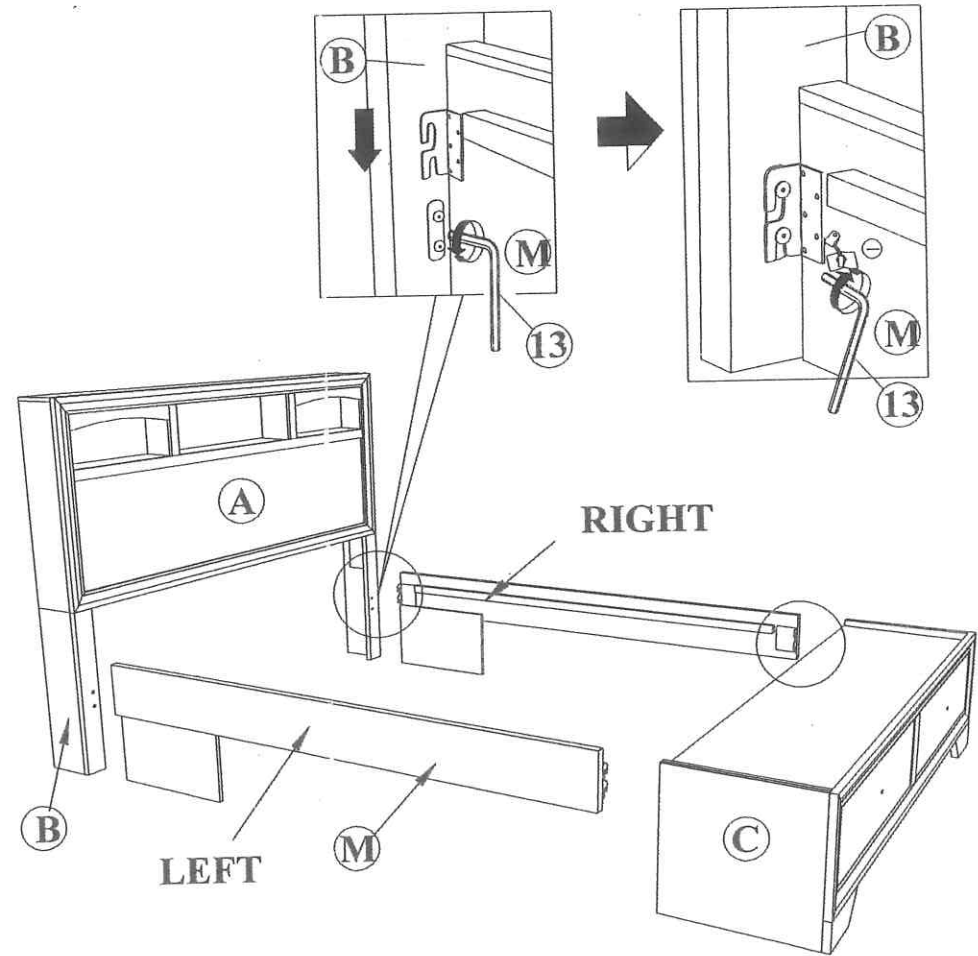

NOTE : MUST TIGHTEN SCREWS PERIODCALLY.SCREW NATURALLY LOOSEN WITH USE.CHECK TIGHTNESS OF ALL SCREW EVERY 6-8 WEEKS.

ASSEMBLY INSTRUCTIONS

STEP 3 : Fix the Bed Slat Support (F) with adjuster, Center Rail (E) to Bed Slat (D). Attach the Assembled Bed Slat to Side Rail (M) Loosen and Tighten Adjuster for the Stability of Bed. Laterly, Tighten the Bed Slat (F) with JCBC Screw (11).

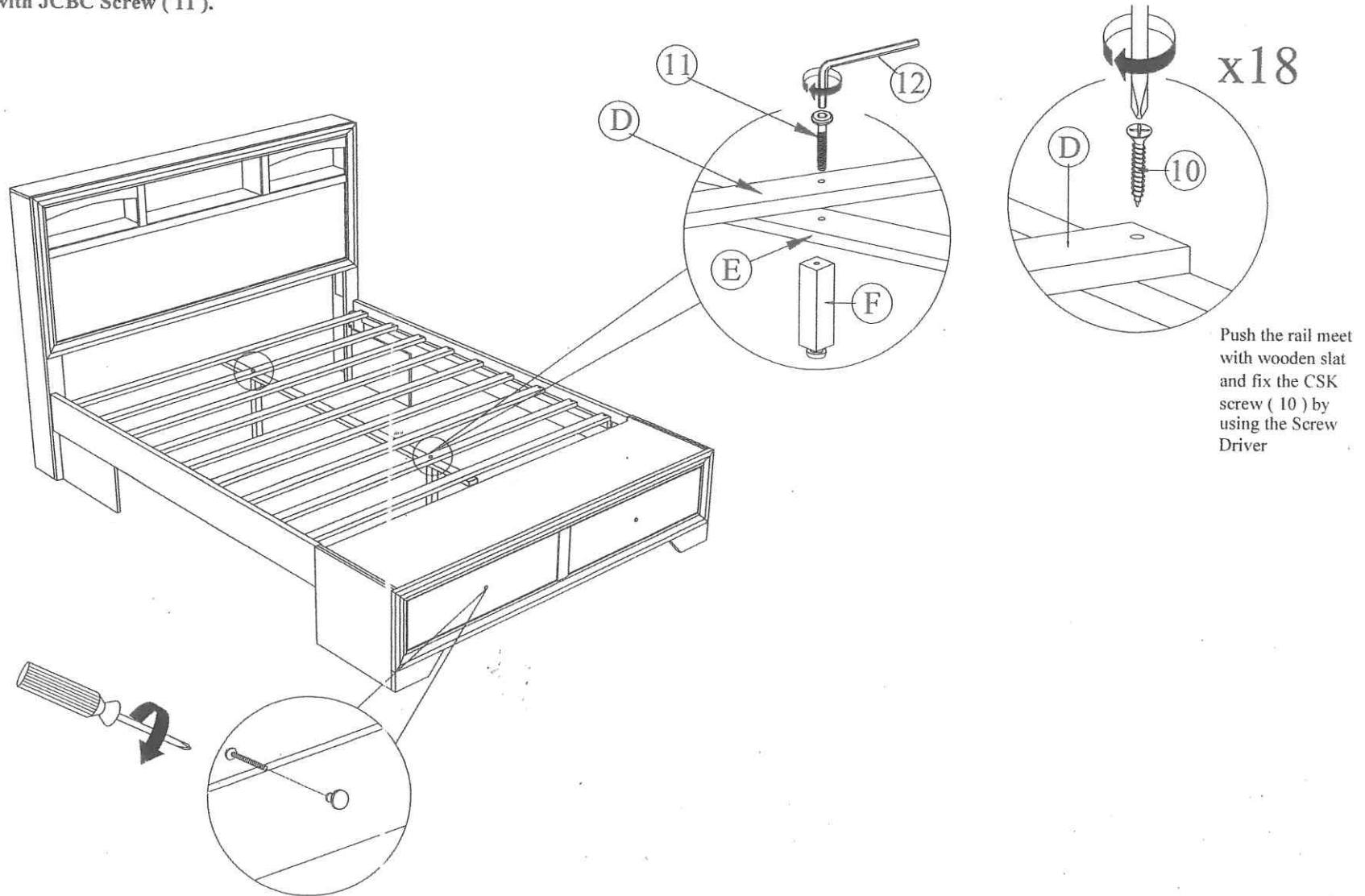

STEP 4 : Install the Handle in front of footboard drawer. Tighten the Handle Screw using Screw Driver.(Not Included)

NOTE : MUST TIGHTEN SCREWS PERIODCALLY. SCREW NATURALLY LOOSEN WITH USE. CHECK TIGHTNESS OF ALL SCREW EVERY 6-8 WEEKS.

ASSEMBLY INSTRUCTIONS

STEP 5(a) : Place the trundle drawer front panel (G) on clean surface then Fix the trundle drawer box side panel (H) by inserting a dowel (9) then tighten with csk screw (7) using Screw Driver as per diagram shown.(DO NOT FULLY TIGHTEN IN THIS STEP)

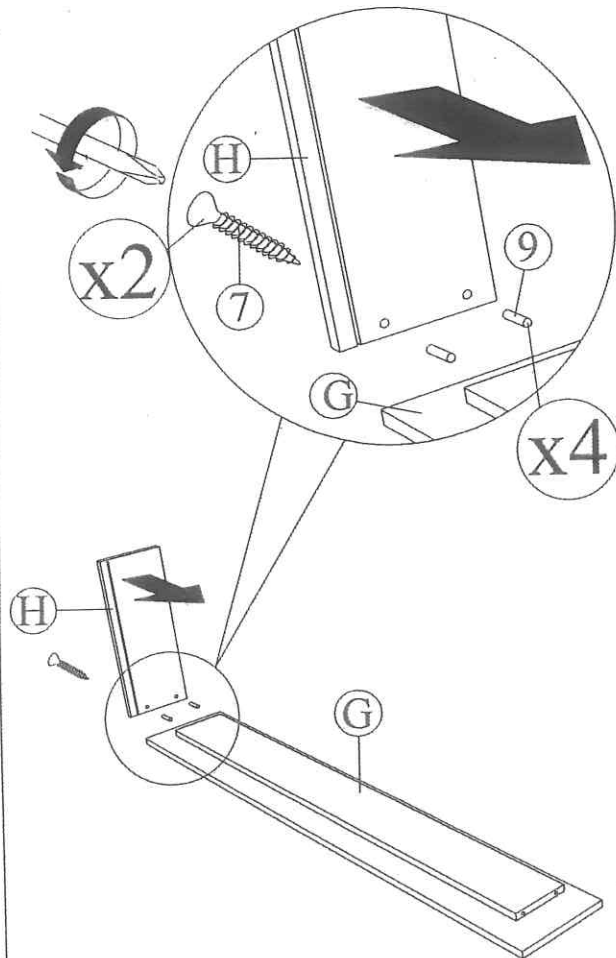

STEP 5 (b) : Slide in the bottom drawer panel (J) inside the groove of trundle drawer box side panel (H) and push it down to trundle front panel (G) as per diagram shown.

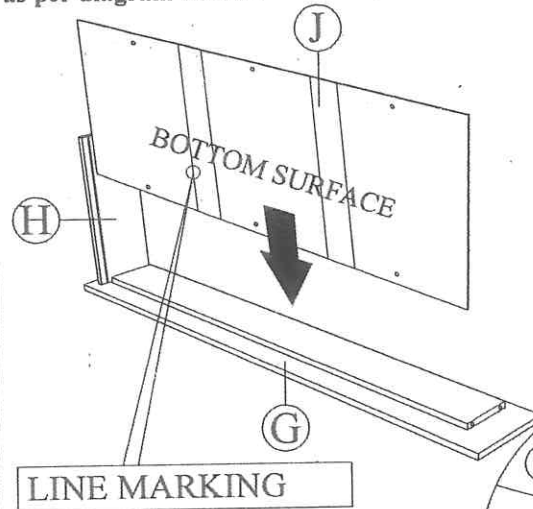

STEP 5 (c) : Fix the trundle drawer back panel (I) and trundle drawer box side panel (H) by inserting a dowel (9) then tighten with csk screw (7) using Screw Driver as per diagram shown. (FULLY TIGHTEN ALL SCREWS IN THIS STEP)

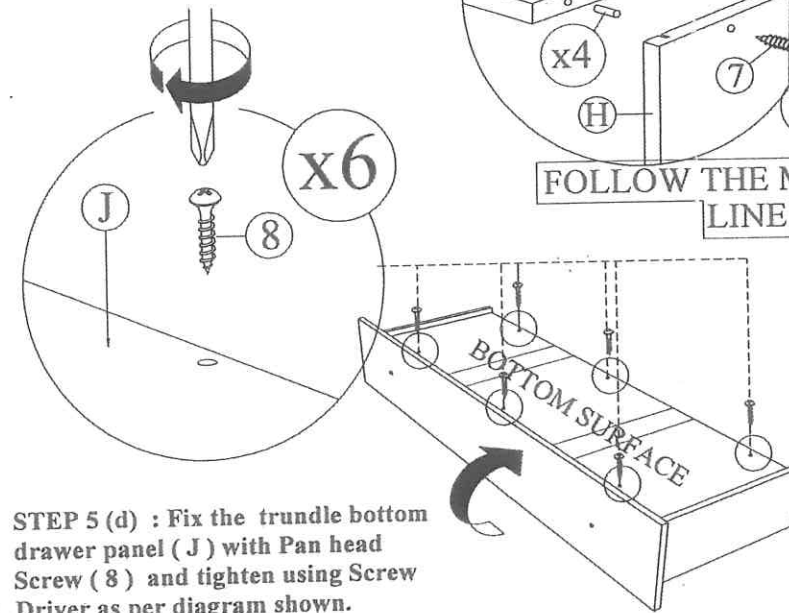
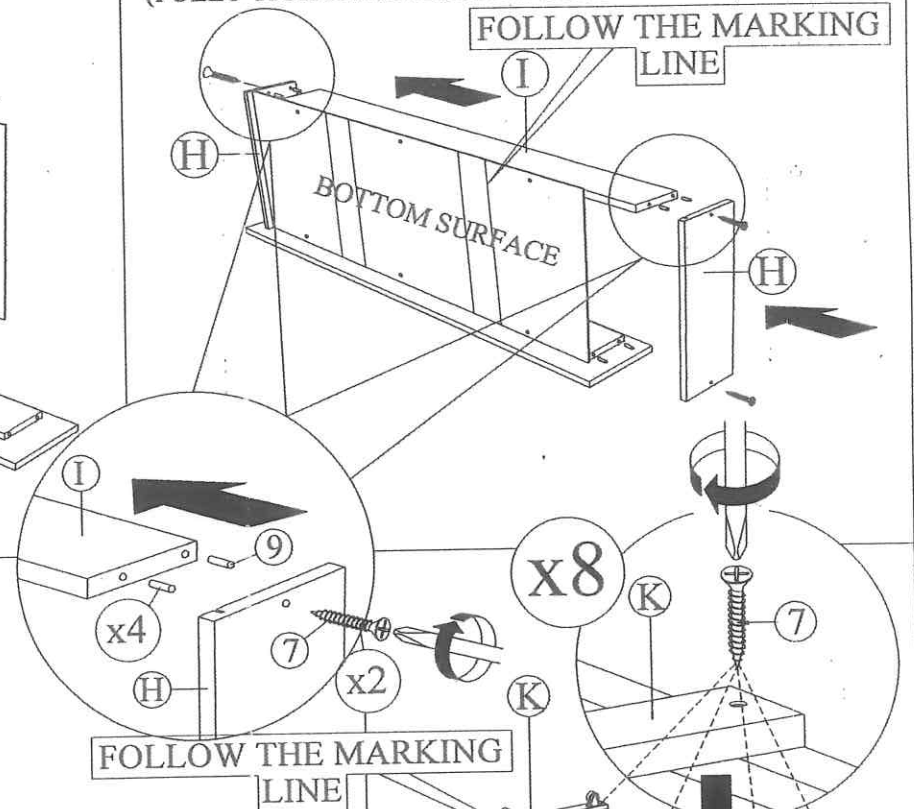

STEP 5 (d) : Fix the trundle bottom drawer panel (J) with Pan head Screw (8) and tighten using Screw Driver as per diagram shown.

STEP 5 (e) : Fix the trundle bottom support rail (K) & (L) and tighten using Screw Driver as per diagram shown.

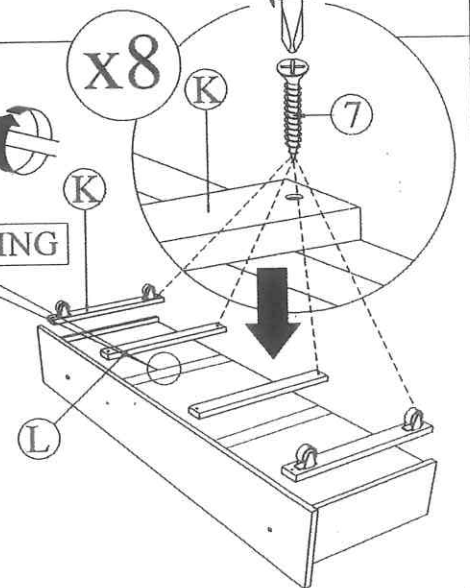

NOTE : MUST TIGHTEN SCREWS PERIODCALLY.SCREW NATURALLY LOOSEN WITH USE.CHECK TIGHTNESS OF ALL SCREW EVERY 6-8 WEEKS.

ASSEMBLY INSTRUCTIONS

STEP 6 : Install the Handle drawer (5) in front of Trundle drawer (G). Tighten the Handle Screw (6) using Screw Driver.(Not Included)

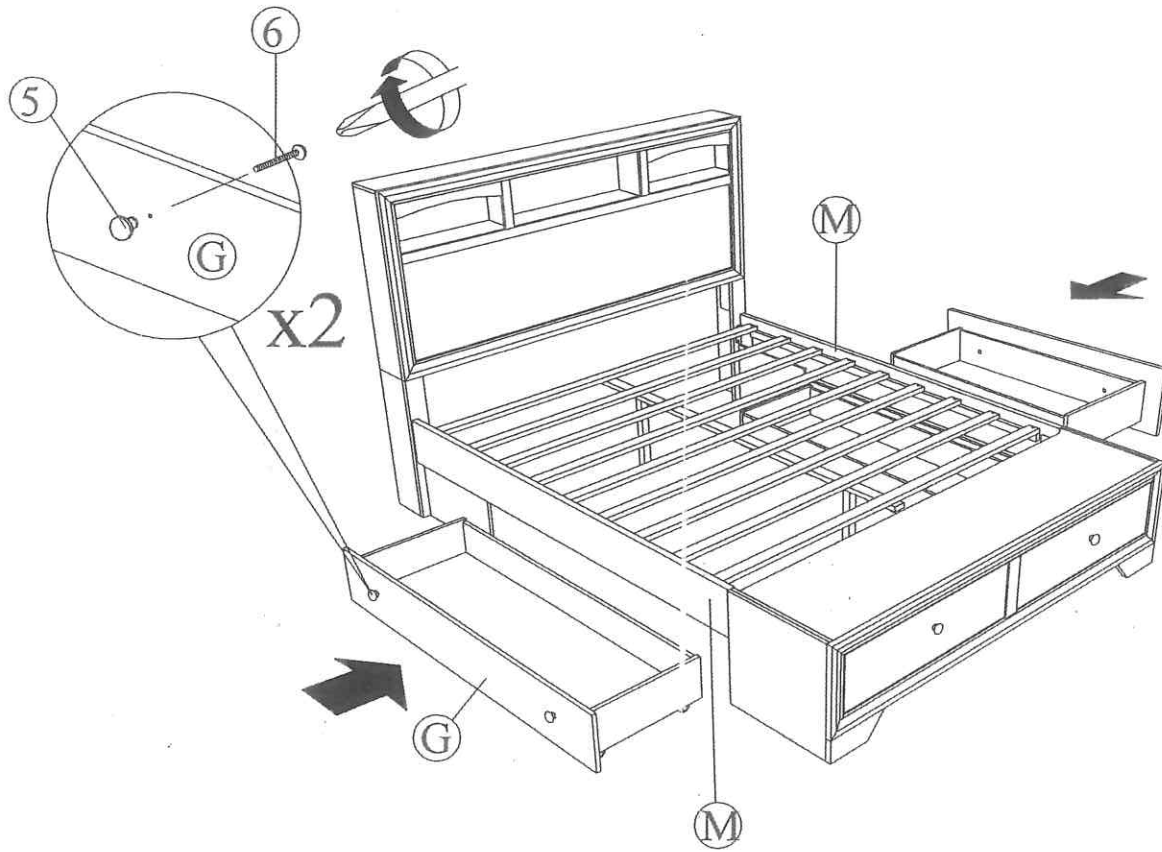

STEP 7 : Push The complete assembled Trundle drawer into side rail (M) as per diagram shown.

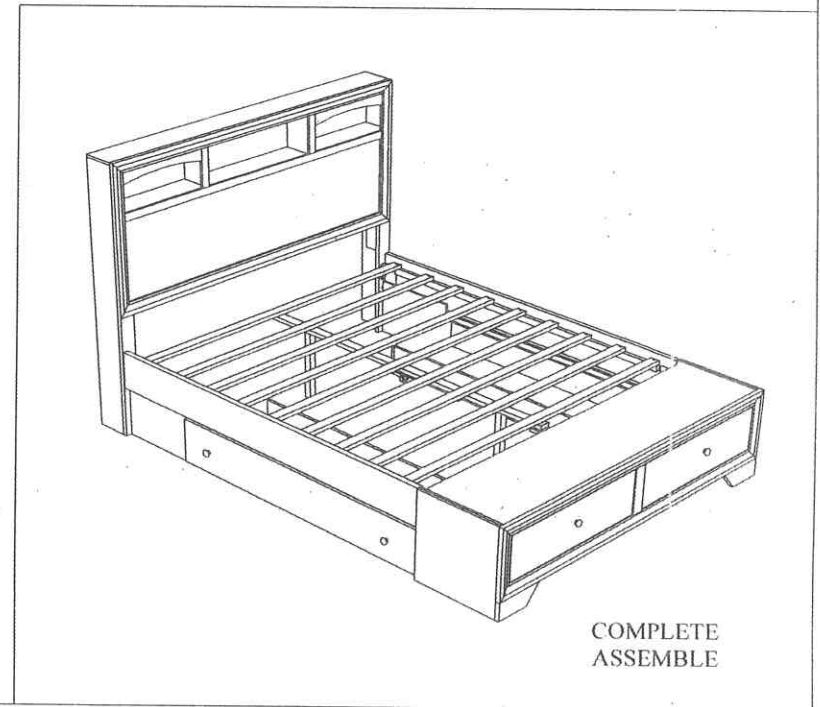

NOTE : MUST TIGHTEN SCREWS PERIODCALLY.SCREW NATURALLY LOOSEN WITH USE.CHECK TIGHTNESS OF ALL SCREW EVERY 6-8 WEEKS.