

## NOTICE

- Please make sure that you have all parts indicated and they are in good condition before you begin assembly of this item. Refer to part list and hardware list below for guidance.
- This item should be assembled on a soft surface to prevent scratching the finish during assembly
- This item may require periodic tightening.
- If you are having difficulty, our friendly customer care team is always here to help.

## PREPARATION









- Before beginning assembly of product, make sure all parts are present. Compare parts with part contents list and hardware contents list.
- If any part is missing or damaged, do not attempt to assemble the product.
- Estimated Assembly time : **10 minutes**
- Tools required for assembly (Include) : **Allen Key**

## CARE AND MAINTENANCE

### WOOD CARE

Adhesive left pads should always be applied to areas of furniture which make direct contact with flooring, said application will prevent damage to the furniture and or surfaces on which the furniture lies. objects placed on articles of furniture

### Part List and Hardware List

PIECE	DESCRIPTION	PICTURE	QTY
a	Side Right & Left		2 x
b	Bottom of Cushion		1 x
c	Back Rest		1 x
d	Support Back Leg		1 x
e	Support Front Leg		1 x
f	Cushion		1 x
HW1	Nuts M8 x 40 mm		12 x
HW2	Allen Key Size M8		1 x
HW2	Bolt Plastic Caps		12 x

should rest on non abrasive material as to prevent damage to the wood finish.

Objects whose composition consists of plastic and rubber are known to discolor and damage the wood surface on which they rest. Wipe up spills immediately and avoid common hazards such as hot dishes, harsh solvents and abrasives. Cleaning should be done with a soft lint free cotton cloth dampened with water or furniture polish. On highly used surfaces we recommend applying a quality paste wax which should be used on a regular basis to provide additional protection from scratches and spills. How often you apply the wax depends on how much wear the furniture receives

# Owner Manual

Product Dimensions : 23" x 23.50" x 36"

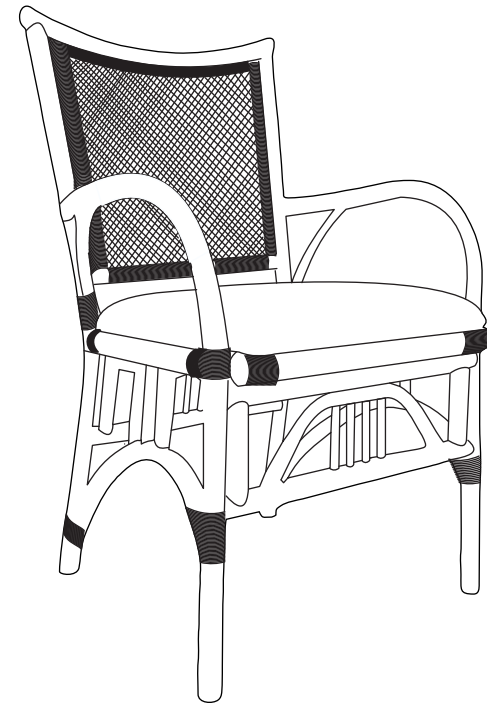

  **WARNING**    
Weight Capacity : 225 lbs

Warning : Do not stand on Chair  
Warning : Do not over torque bolts

# PREPARATION

- \* Before beginning assembly of product, make sure all parts are present. Compare parts with part contents list and hardware contents list.
- \* If any part is missing or damaged, do not attempt to assemble the product.
- \* Estimated Assembly Time: 10 minutes.
- \* Tools Required for Assembly (included): Allen Key
- \* If you are having difficulty, our friendly Customer Care team is always here to help.

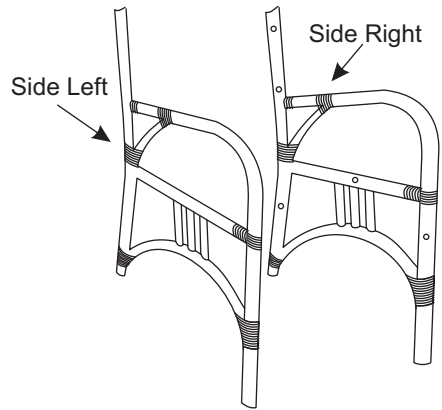

**Step 1 :** Attach the right and left legs to the front and rear support bars

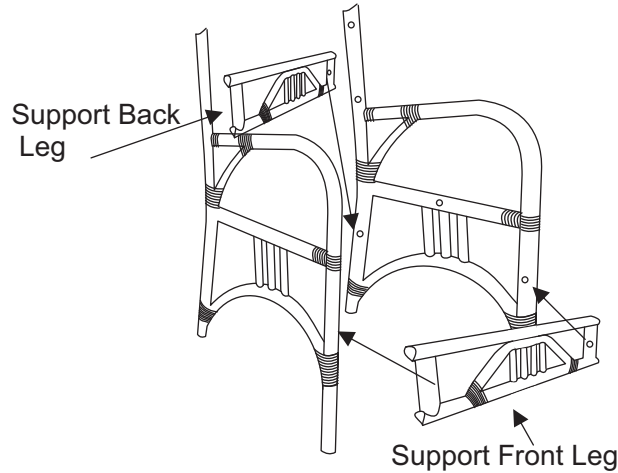

**Step 2 :** Insert all nuts and bolts, tightening them only enough to hold the parts in place. Do not fully tighten any nuts at this stage.

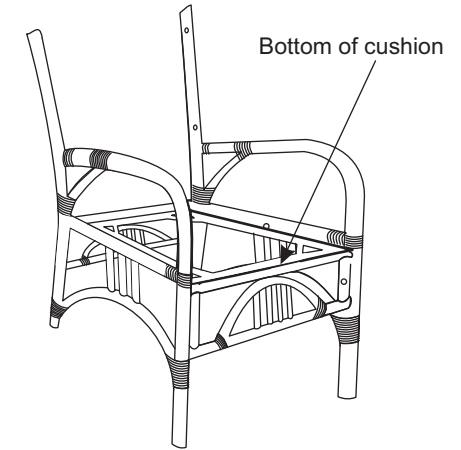

**Step 3 :** Ensure that all nuts and bolts are installed before proceeding. This allows the frame to align properly during assembly.

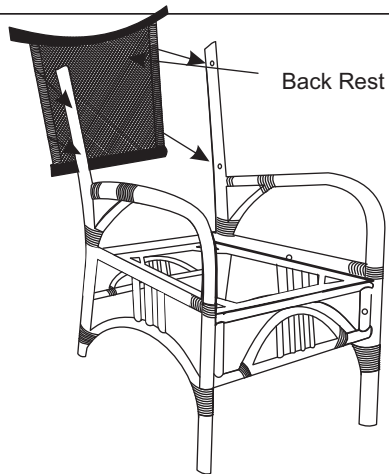

**Step 4 :** Attach the backrest to the chair frame as shown in the photo. Insert all bolts loosely at first and do not fully tighten them until all bolts are in place and properly aligned.

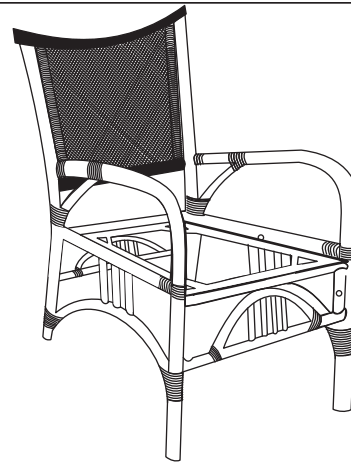

**Step 5 :** Place the assembled frame on a flat, level surface and check that all components are correctly aligned. Fit the plastic caps over the exposed nuts to provide a neat and finished appearance.

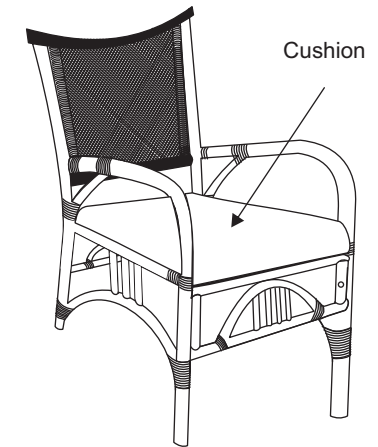

**Step 6 :** Position the cushion on the seat and ensure it is properly seated and secured. Perform a final inspection to confirm that all fasteners are tightened and the chair is stable before use.