

# Dining Chair (2 pack)

**Color:**

Gray / Beige

---

Congratulations on your latest furniture purchase! This furniture has been developed with quality, convenience and style in mind. We trust it will provide you with many years of exceptional comfort and service.

Before beginning assembly, we encourage you to familiarize yourself with your new furniture piece by taking a few minutes to go through this booklet. It contains important information on our warranty and care tips to keep your furniture looking as good as new.

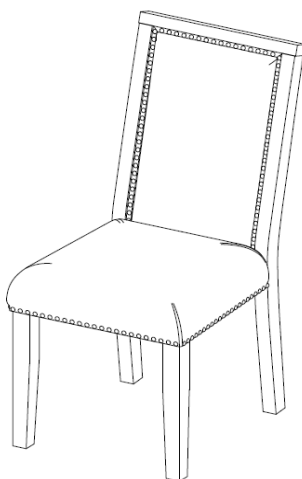

Date of Purchase: \_\_\_\_ / \_\_\_\_ / \_\_\_\_

Lot Number: \_\_\_\_\_

(located on carton)

Questions, concerns, missing parts? Customer satisfaction is important to us.  
**CONTACT OUR CUSTOMER SERVICE DEPARTMENT BEFORE RETURNING PRODUCT  
TO THE RETAILER.**

NOTE: THIS INSTRUCTION BOOKLET CONTAINS **IMPORTANT** SAFETY INFORMATION.  
PLEASE READ AND KEEP FOR FUTURE REFERENCE.

## CUSTOMER SERVICE

You can also contact us by writing to the address listed below. Please include the product model number, color and a detailed description of your enquiry.

## NOTES AND INSTALLATION

- \*Ensure all parts and components are present before beginning assembly.
- \*Assemble on soft, smooth surface to prevent damage to product finish.
- \* **Do not** use power tools.
- \* CAUTION: Adult assembly required.
- \* Assembly and handling may require two people.
- \* Estimated assembly time is 30 minutes.

## CARE, CLEANING AND MAINTENANCE

Dust regularly with a soft, dry cloth to prevent soil build up. Keep away from heat to avoid glazing, melting or scorching. Use a professional cleaning service to clean the fabric.

Check all bolts, screws and fasteners periodically and tighten them if necessary.



**WARNING: Should this product become damaged, and/or components are broken or missing, DO NOT USE.**



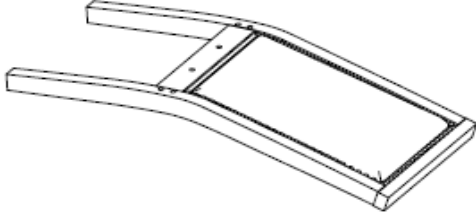
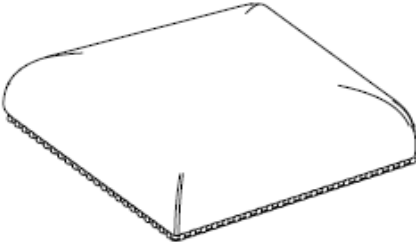
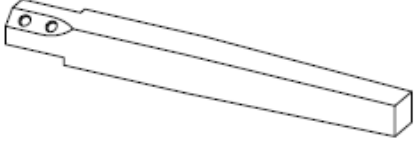

# Dining Chair (2 pack)

## PARTS LIST

A	B	C
		
CHAIR BACK 2 PCS	SEAT CUSHION 2 PCS	LEG 4 PCS

# Dining Chair (2 pack)

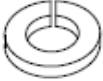
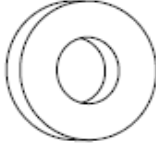
## HARDWARE LIST

1  Ø5/16"*3"	2  Ø5/16"*2"	3  Ø5/16"*1-1/2"
BOLT 8 PCS	BOLT 8 PCS	BOLT 4 PCS
4 	5 	6 
SPRING WASHER 20 PCS	FLAT WASHER 20 PCS	ALLEN KEY 1 PC

# Dining Chair (2 pack)

## STEP 1:

Attach the legs (C) to seat cushion (B) with bolts (2), spring washers (4) and flat washers (5) as shown below.

Tighten the bolts (2) with the Allen key (6).

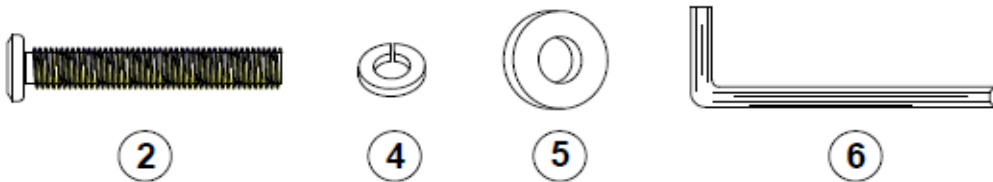
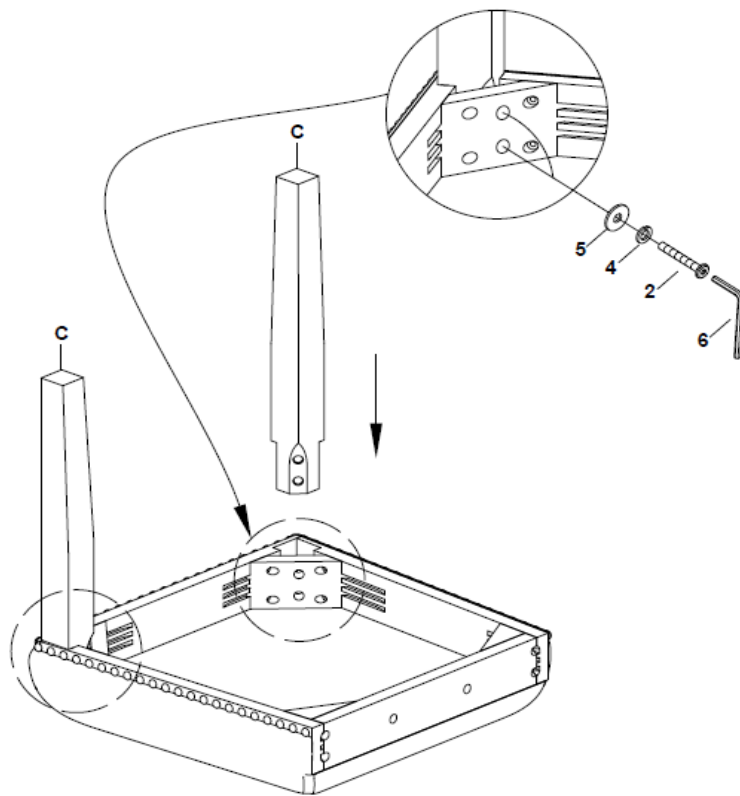

# Dining Chair (2 pack)

## STEP 2:

Attach the chair back (A) to the seat cushion (B) with bolts (1 & 3), spring washers (4) and flat washers (5) as shown below.

Tighten the bolts(1 & 3) with the Allen key (6).

Turn the chair upright.

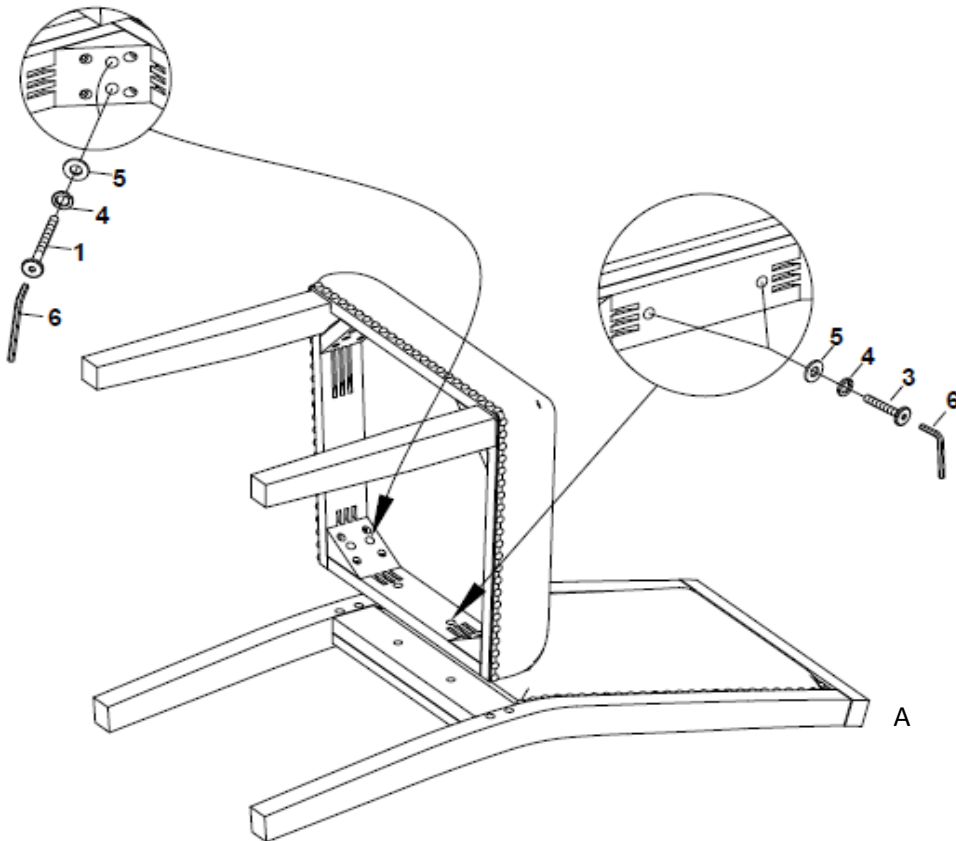

1



3



4



5



6

# Dining Chair (2 pack)



**CAUTION:** This unit is intended for use only with the products and/or maximum weights indicated. Use with other products and/or products heavier than the maximum weights indicated may result in instability or cause possible injury.

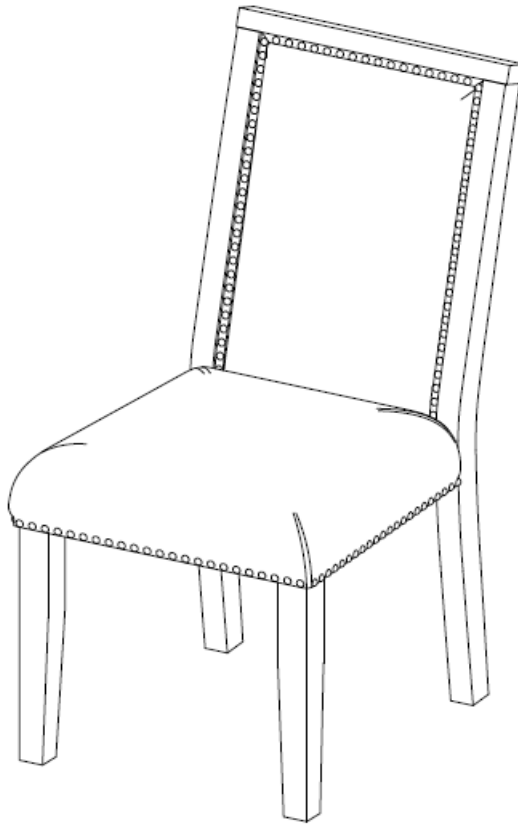

That's it ! You've finished assembling your dining chair.

**DO NOT RETURN PRODUCT TO THE RETAILER.**

If a part is missing or damaged, contact our customer service department.

We will replace the part FREE of charge.



# Silla de comedor (paquete de 2)

Color:

Gris / Beige

---

¡Felicitaciones por su nueva compra de un mueble! Los muebles de la línea han sido diseñados con la calidad, la comodidad y el estilo en mente. Estamos seguros de que este mueble le servirá por muchos años con su comodidad excepcional.

Le recomendamos que antes de comenzar a armarlo se familiarice con su nueva compra y tome unos minutos de su tiempo para leer este manual. Contiene información importante sobre nuestra garantía y consejos de cuidados para que su mueble siempre conserve su apariencia de nuevo.

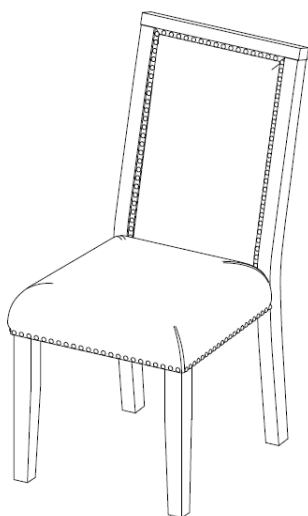

Fecha de compra: \_\_\_\_ / \_\_\_\_ / \_\_\_\_

Número de lote: \_\_\_\_\_

(tomado del cartón)

Preguntas, inquietudes, partes que faltan? La satisfacción del cliente es importante para nosotros.  
**CONTACTE NUESTRO DEPARTAMENTO DE SERVICIO AL CLIENTE ANTES DE DEVOLVER EL PRODUCTO A LA TIENDA.**

NOTA: ESTE MANUAL DE INSTRUCCIONES CONTIENE INFORMACIÓN DE SEGURIDAD **IMPORTANTE**.  
POR FAVOR, LÉALO Y CONSÉRVELO PARA CONSULTARLO EN EL FUTURO.

## SERVICIO AL CLIENTE

También puede contactarnos escribiendo a la dirección que figura a continuación. Por favor incluya el número de modelo del producto, el color y una descripción detallada de su pregunta.

## NOTAS E INSTALACIÓN

- \* Asegúrese de tener todas las piezas y componentes antes de comenzar a armar el producto.
- \* Ensamble sobre una superficie suave y lisa para evitar daños en el acabado del producto.
- \* **NO** use herramientas eléctricas.
- \* **PRECAUCIÓN:** Debe ser armada por un adulto.
- \* Pueden necesitarse dos personas para armar y manipular el producto.
- \* Tiempo estimado para armar el producto: 30 minutos

## CUIDADO, LIMPIEZA Y MANTENIMIENTO

Quite el polvo regularmente con un paño suave y seco, para evitar que la suciedad se acumule. Mantenga alejado del calor para evitar que se agriete, se funda o se quemé. Utilice un servicio de limpieza profesional para limpiar la tela.



Revise todos los pernos, tornillos y sujetadores periódicamente y apriételos si es necesario.



**ADVERTENCIA: Si este producto está dañado y/o ciertas piezas faltan o están rotas, NO LO USE.**



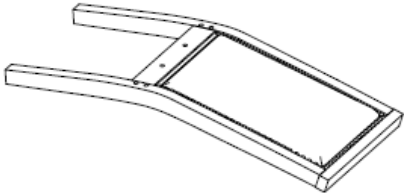
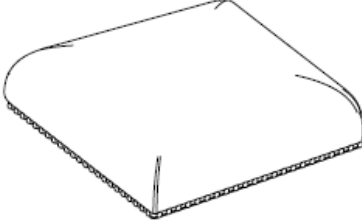



# Silla de comedor (paquete de 2)

## LISTA DE PIEZAS

A	B	C
		
<p>RESPALDAR 2 PZAS</p>	<p>COJÍN 2 PZAS</p>	<p>PATA 4 PZAS</p>

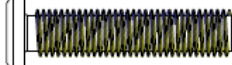
# Silla de comedor (paquete de 2)

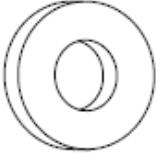
## LISTA DE TORNILLOS Y ACCESORIOS

<p>1</p>  <p>Ø5/16"*3"</p>	<p>2</p>  <p>Ø5/16"*2"</p>	<p>3</p>  <p>Ø5/16"*1-1/2"</p>
<p>PERNO 8 PZAS</p>	<p>PERNO 8 PZAS</p>	<p>PERNO 4 PZAS</p>
<p>4</p> 	<p>5</p> 	<p>6</p> 
<p>ARANDELA RESORTE 20 PZAS</p>	<p>ARANDELA PLANA 20 PZAS</p>	<p>LLAVE ALLEN 1 PZA</p>

# Silla de comedor (paquete de 2)

## ETAPA 1:

Fije las patas (C) al cojín (B) con los pernos (2), las arandelas elásticas (4) y las arandelas planas (5) como se muestra a continuación.  
Apriete los pernos (2) con la llave Allen (6).

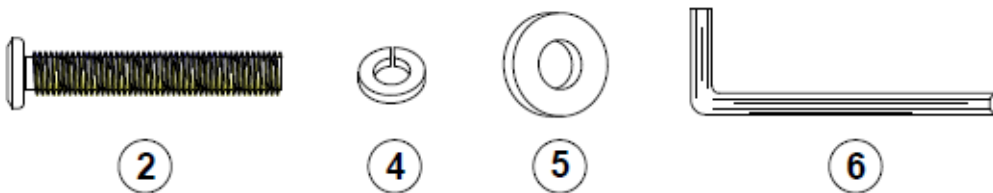
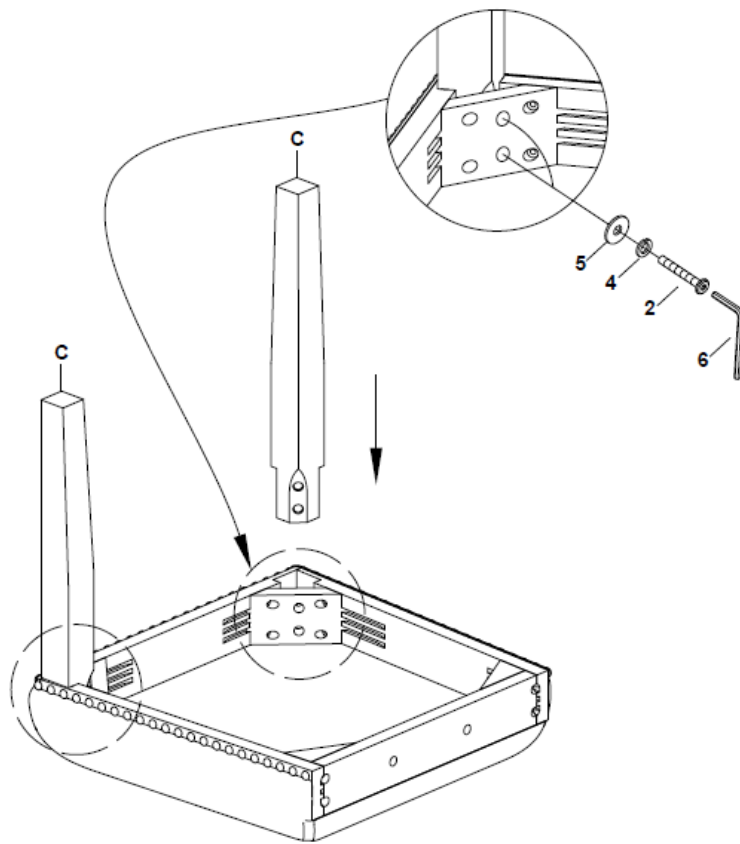

# Silla de comedor (paquete de 2)

## ETAPA 2:

Fije el respaldar (A) a el cojín (B) con los pernos (1 y 3), las arandelas elásticas (4) y las arandelas planas (5) como se muestra a continuación.

Apriete los pernos (1 y 3) con la llave Allen (6).

Voltee la silla a su posición vertical.

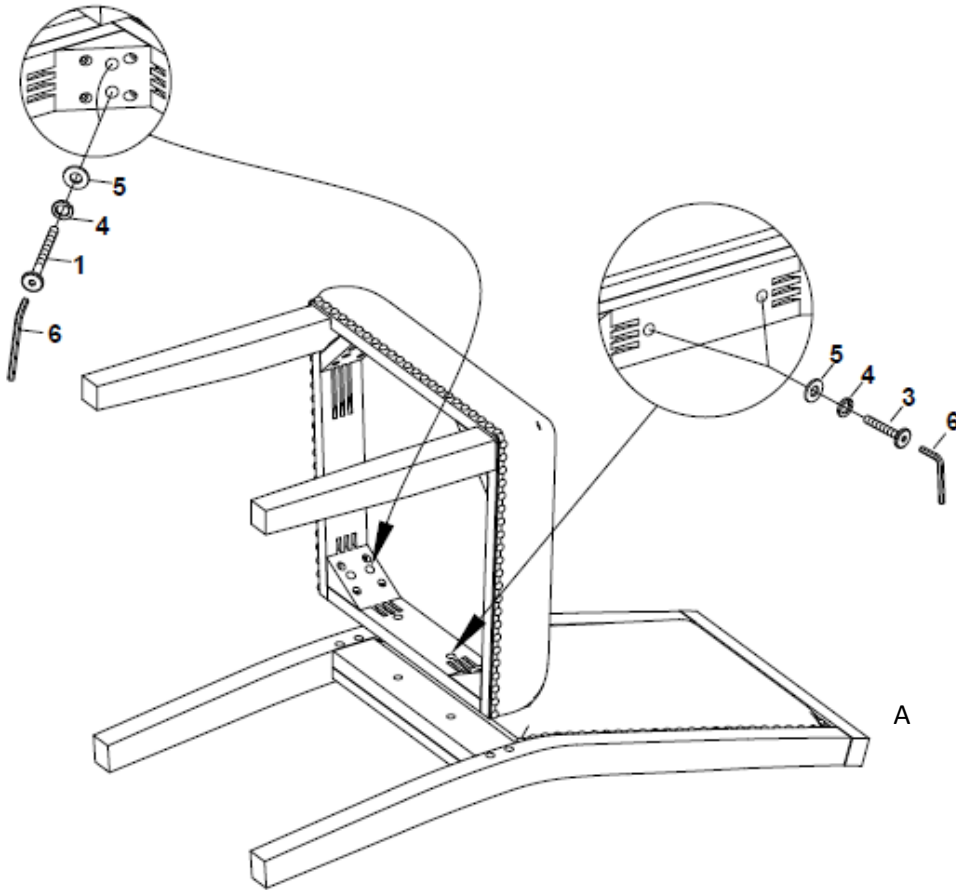

1



3



4



5



6

## Silla de comedor (paquete de 2)



**PRECAUCIÓN:** Esta unidad está diseñada para ser utilizada únicamente con los productos y/o pesos máximos indicados. Su uso con otros productos y/o productos más pesados que los pesos máximos indicados puede provocar inestabilidad o causar lesiones.

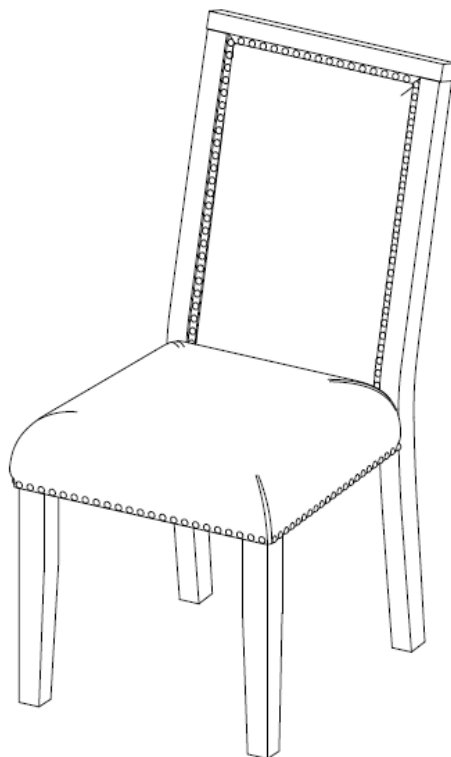

Listo! Ha terminado de armar su silla de comedor.

**NO DEVUELVA EL PRODUCTO A LA TIENDA.** Si falta una pieza o está dañada, contacte nuestro departamento de servicio al cliente. Reemplazaremos la pieza **SIN cargo alguno.**



## Chaise de salle à manger (emballage de 2)

Couleur:

Gris / Beige

---

Félicitations pour votre dernier achat d'un meuble ! Les meubles de la ligne ont été conçus ayant en tête la qualité, la commodité et le style. Nous sommes convaincus que ce meuble vous servira durant de nombreuses années avec un confort exceptionnel.

Nous vous encourageons à vous familiariser avec les caractéristiques de votre nouveau meuble avant de commencer l'assemblage; prenez donc quelques minutes pour lire ce manuel. Il contient de l'information importante concernant notre garantie et des conseils d'entretien pour vous assurer de garder votre meuble aussi beau qu'aux premiers jours.

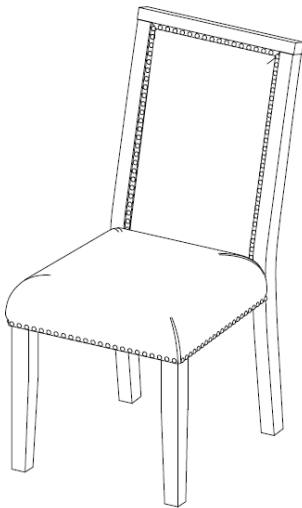

Date d'achat: \_\_\_\_ / \_\_\_\_ / \_\_\_\_

Numéro de lot: \_\_\_\_\_

(sur la boîte)

Des questions, des préoccupations, des pièces manquantes? La satisfaction du client est importante pour nous chez. **CONTACTEZ NOTRE SERVICE À LA CLIENTÈLE AVANT DE RETOURNER LE PRODUIT AU DÉTAILLANT.**

NOTE: CE MANUEL D'INSTRUCTIONS CONTIENT INFORMATION DE SÉCURITÉ **IMPORTANTE**. VEUILLEZ LE LIRE ET LE CONSERVER POUR RÉFÉRENCE ULTÉRIEURE.

## SERVICE À LA CLIENTÈLE

Vous pouvez également nous contacter en écrivant à l'adresse ci-dessous. S'il vous plaît inclure le numéro de modèle du produit, la couleur et une description détaillée de votre demande.

## NOTES ET INSTALLATION

- \* Assurez-vous que toutes les pièces et les composantes sont présentes avant de commencer l'assemblage.
- \* Assembler sur une surface douce et lisse pour éviter d'endommager le fini du produit.
- \* **NE PAS** utiliser d'outils électriques.
- \* **ATTENTION:** Doit être assemblé par un adulte.
- \* L'assemblage et la manipulation nécessitent deux personnes.
- \* Temps d'assemblage estimé: 30 minutes.

## SOIN, NETTOYAGE ET ENTRETIEN

Époussetez régulièrement avec un chiffon doux et sec pour empêcher la poussière de s'accumuler. Gardez loin des sources de chaleur pour éviter le glaçage, la fusion ou les brûlures. Utilisez un service de nettoyage professionnel pour nettoyer le tissu.

Vérifiez régulièrement les boulons/vis et serrez-les si nécessaire.



**AVERTISSEMENT: Si ce produit est endommagé, et/ou des pièces sont brisées ou manquantes, NE PAS UTILISER.**





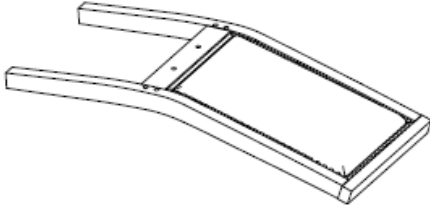
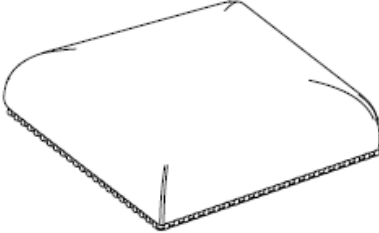
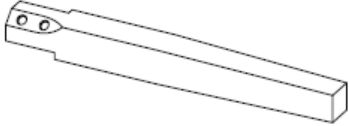

# Chaise de salle à manger (emballage de 2)

## LISTE DES PIÈCES

A	B	C
		
DOSSIER 2 PCES	COUSSIN 2 PCES	PATTE 4 PCES

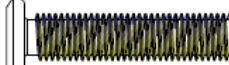
# Chaise de salle à manger (emballage de 2)

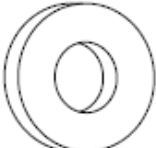
## LISTE DE QUINCAILLERIE

1  Ø5/16"*3"	2  Ø5/16"*2"	3  Ø5/16"*1-1/2"
BOULON 8 PCES	BOULON 8 PCES	BOULON 4 PCES
4 	5 	6 
RONDELLE RESSORT 20 PCES	RONDELLE PLATE 20 PCES	CLE ALLEN 1 PCE

# Chaise de salle à manger (emballage de 2)

## ÉTAPE 1:

Attachez les pattes (C) au coussin (B) à l'aide des boulons (2), des rondelles ressorts (4) et des rondelles plates (5) comme indiqué ci-dessous.  
Serrer les vis (2) avec la clé Allen (6).

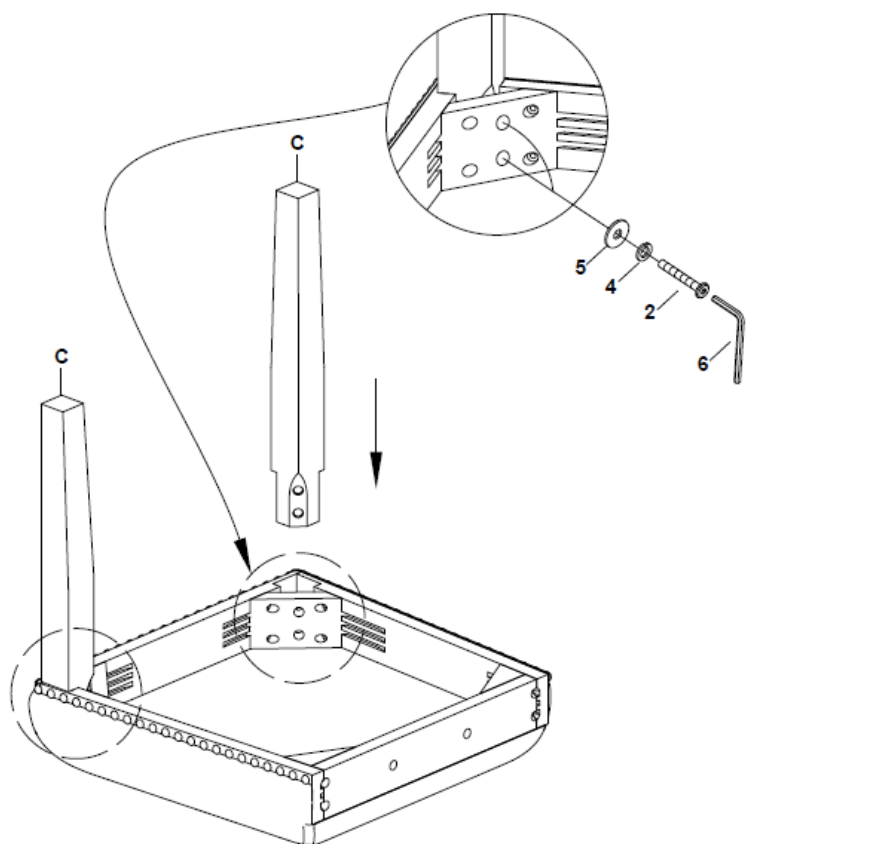

2



4



5



6

# Chaise de salle à manger (emballage de 2)

## ÉTAPE 2:

Attachez le dossier (A) au coussin (B) à l'aide des boulons (1 et 3), des rondelles ressorts (4) et des rondelles plates (5), comme illustré ci-dessous.

Serrer les vis (1 et 3) avec la clé Allen (6).

Tournez la chaise à sa position verticale.

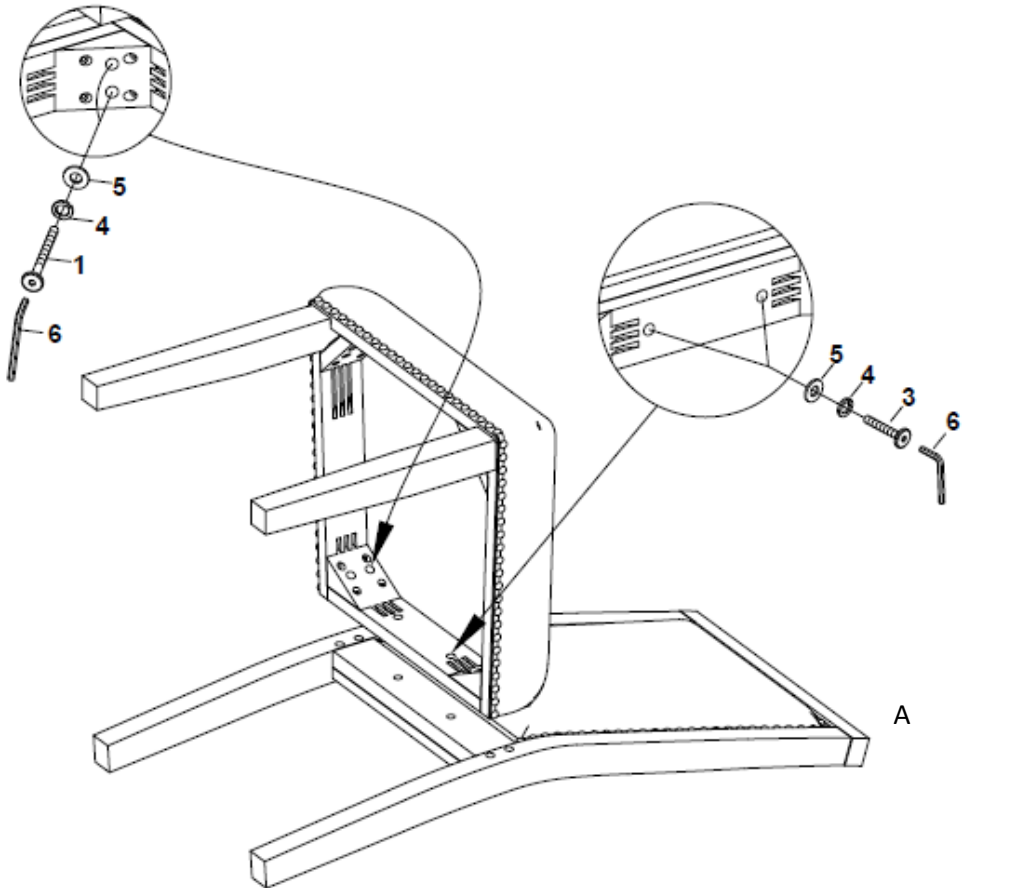

1



3



4



5



6

## Chaise de salle à manger (emballage de 2)



**ATTENTION:** Cette unité est destinée à être utilisée uniquement avec les produits et/ou les poids maximum indiqués. L'utilisation avec d'autres produits et/ou des produits plus lourds que les poids maximum indiqués peut entraîner une instabilité ou causer des blessures.

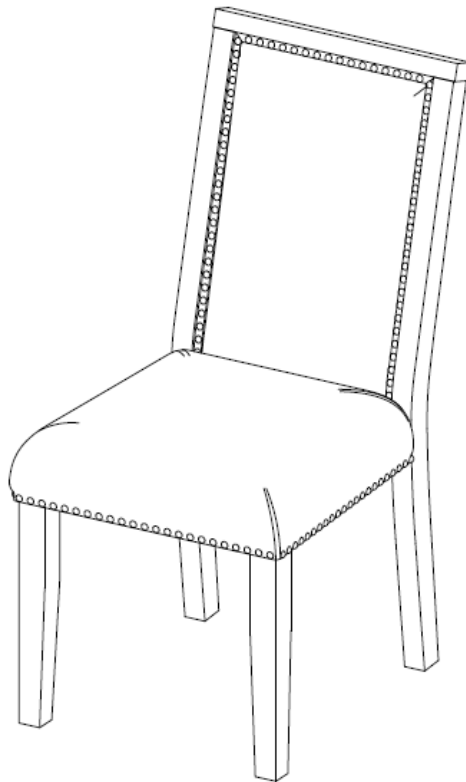

C'est tout ! Vous avez fini d'assembler votre chaise.

**NE PAS RETOURNER CE PRODUIT AU MAGASIN.** Si une pièce est manquante ou endommagée, contactez notre Service à la clientèle. Nous remplacerons la pièce **GRATUITEMENT.**

