

GMWD

ASSEMBLY INSTRUCTIONS

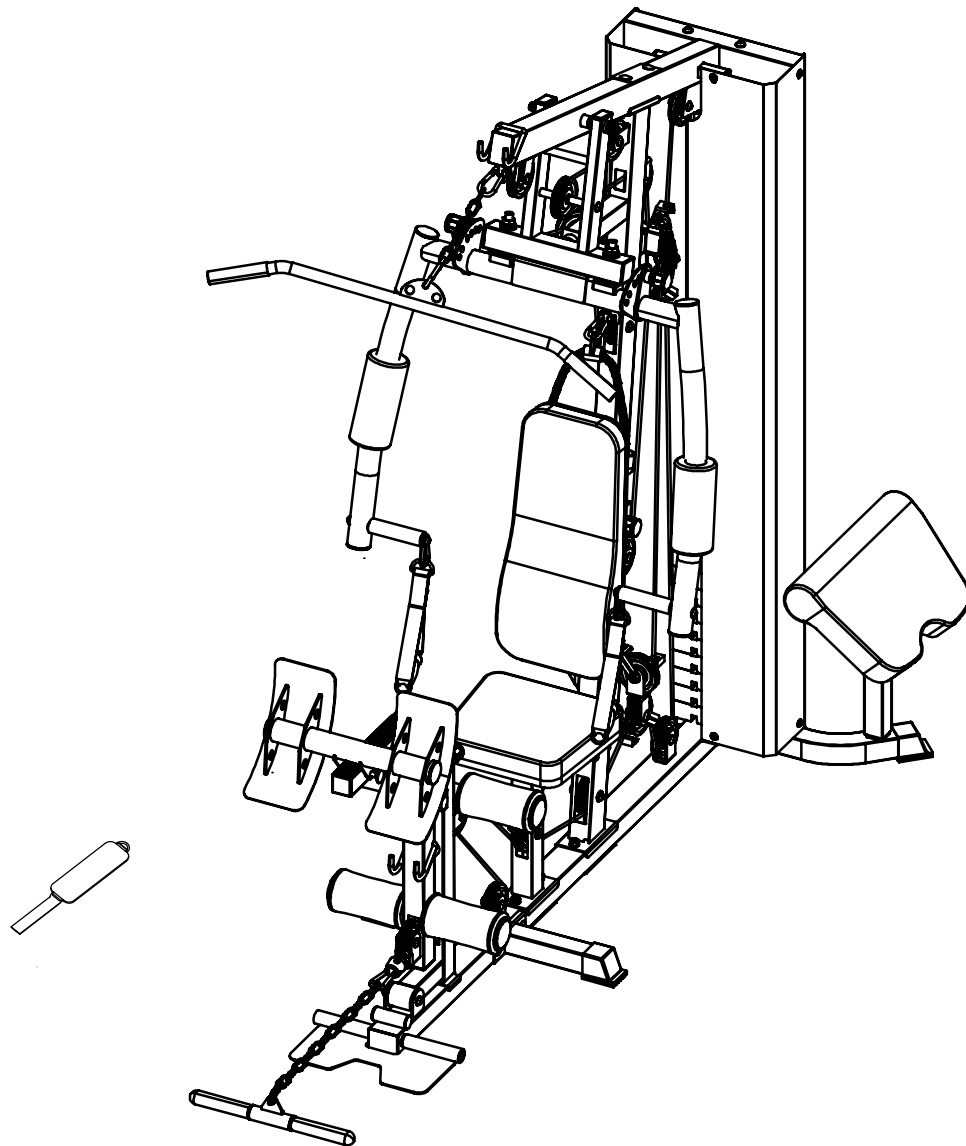

HGS

Read all precautions and instructions in this manual before using this

| | | |
|------------------|-------|----|
| Assembly Caution | ----- | 4 |
| Part List | ----- | 5 |
| Hardware List | ----- | 6 |
| Step 1 | ----- | 7 |
| Step 2 | ----- | 8 |
| Step 3 | ----- | 9 |
| Step 4 | ----- | 10 |
| Step 5 | ----- | 11 |
| Step 6 | ----- | 12 |
| Step 7 | ----- | 13 |
| Step 8 | ----- | 14 |
| Step 9 | ----- | 15 |
| Step 10 | ----- | 16 |

| | | |
|------------------------|-------|----|
| Step 11 | ----- | 17 |
| Step 12 | ----- | 18 |
| Step 13 | ----- | 19 |
| Step 14 | ----- | 20 |
| Step 15 | ----- | 21 |
| Step 16 | ----- | 22 |
| Step 17 | ----- | 23 |
| Step 18 | ----- | 24 |
| After-Sale Information | ----- | 25 |

ASSEMBLY CAUTION

Please carefully read the following information before installation

Assembling requires at least two people

Do not tighten all screws before assembly is complete

Ensure that all accessories are complete. If not, please contact us via email



If you are missing any parts, or otherwise have any warranty issues, please contact us first.

Shortcut: A Lot of People Doing That Way

To enhance your installation process for both speed and convenience, consider removing all accessories from the box, carefully opening the packaging, and arranging everything neatly on the floor. This preparation can streamline your setup experience.

The following tools might help you improve your installation experience

Adjustable wrenches



Rubber hammers

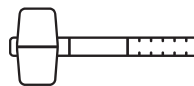

Socket set

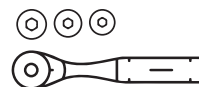

Electric Wrench

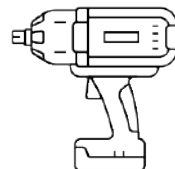

WARNING



Choking hazard. Small parts-Please exercise caution if small children or pets are present.











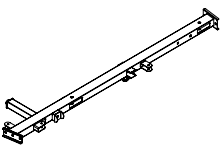
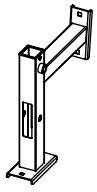
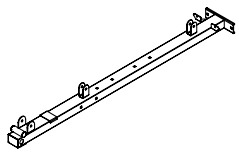
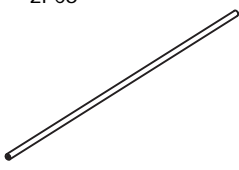
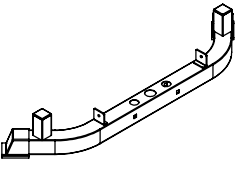
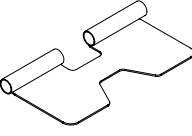
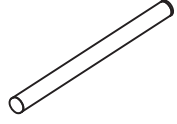
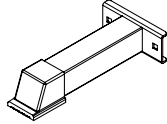
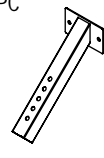
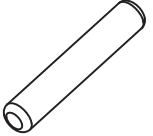
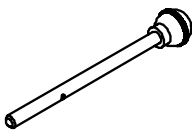

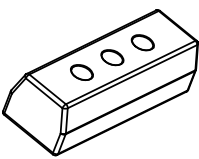
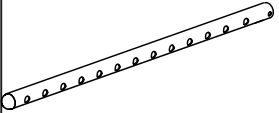

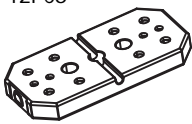
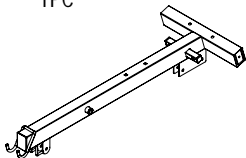
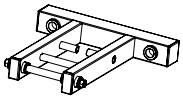
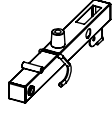
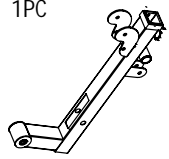
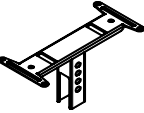
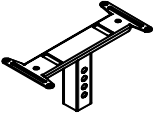
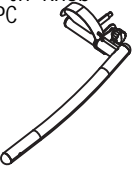
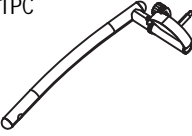
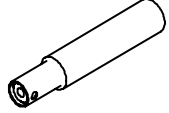
Sharp objects may be involved. Use precaution and protection.

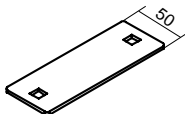
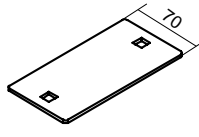
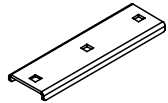
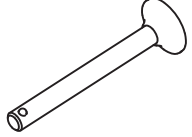

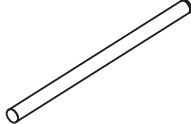
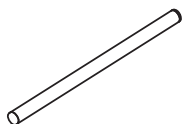

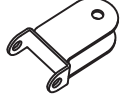
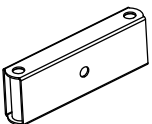
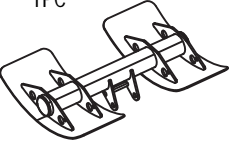

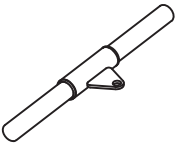



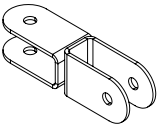
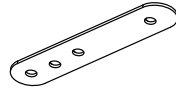
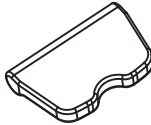

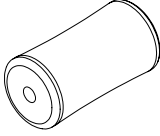
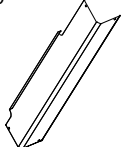
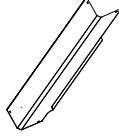
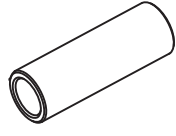
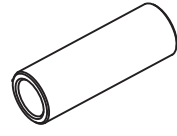

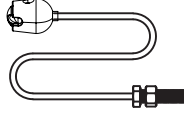
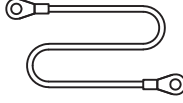
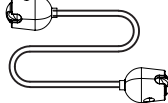
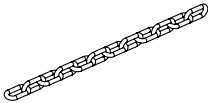
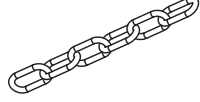
Heavy object. Use lifting aids and proper lifting techniques when moving

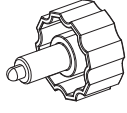

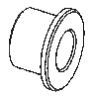
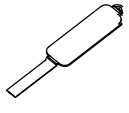
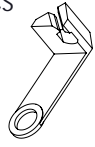





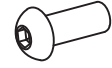
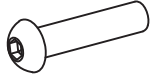
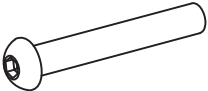
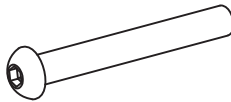
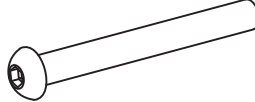
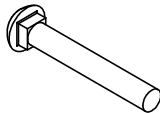
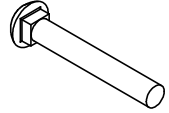
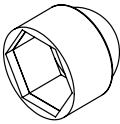

PARTS LIST

| | | | | |
|---|---|---|---|--|
| A1 Front Upright 1PC  | A2 Seated Pad Connecting 1PC  | A3 Front Base 1PC  | A4 Guide Rod 2PCS  | A5 Back Base 1PC  |
| A6 Foot Pedal 1PC  | A7 Footboard Connecting Rod 1PC  | A8 Stable Base 2PCS  | A9 Preacher Pad Connecting 1PC  | A10 Weight Stack Pin 1PC  |
| B1 Weight Stack Pin 1PC  | B2 Weight Washer 1PC  | B3 Top Weight Stack 1PC  | B4 Insert Lifting Rod 1PC  | B5 Weight Stack Washer 1PC  |
| B6 Weight Stack 12PCS  | B7 Top Frame 1PC  | B8 Jammer Arm Connecting With G5, G6, 20 1PC  | B9 Leg Extension Arm 1PC  | B10 Front Insert Tube With Bushing x2 1PC  |
| C1 Back Pad Connecting 1PC  | C2 Seat Pad Connecting 1PC  | C3 Right Jammer Arm With Knob 1PC  | C4 Left Jammer Arm With Knob 1PC  | C5 Jammer Arm Handle 2PCS  |
| C6 Foam Sleeve 2PCS  | C7 Connecting Plate 2PCS  | C8 Connecting Plate 2 2PCS  | C9 U Connecting Plate 1PC  | C10 Locking Pin 2PCS  |
| D1 Rubber Cushion Pad 2PCS  | D2 Foam Sleeve Roller(433mm) 1PC  | D3 Foam Sleeve Roller(400mm) 1PC  | D4 Foam Plug 4PCS  | D5 Pulley Stand-B 2PCS  |
| D6 Pulley Stand-A 1PC  | D7 Leg Press Pedal 1PC  | D8 Leg Press Pedal Connecting 1PC  | D9 Lat Pull Down Bar 1PC  | D10 Short Straight Bar 1PC  |



PARTS LIST

| | | | | | | |
|---|--|--|--|--|--|--|
| E1 Pulley Stand-C 1PC  | E2 Pulley Stand-D 2PCS  | E3 Preacher Pad 1PC  | E4 Back Pad 1PC  | E5 Seated Pad 1PC  | | |
| E6 Foam Sleeve 4PCS  | E7 Right Shell 1PC  | E8 Left Shell 1PC  | E9 Roller A (60mm) 1PC  | E10 Roller B (63mm) 1PC  | | |
| F1 Pulley 21PCS  | F2 Cable A (2980mm) 1PC  | F3 Cable B (2970mm) 1PC  | F4 Cable C (5065mm) 1PC  | F5 Chain (12) 1PC  | | |
| F6 Chain (6) 1PC  | F7 Clip 7PCS  | F8 Knob 3PCS  | F9 Tricep Rope 1PC  | F10 Cable Handle 2PCS  | | |
| G1 Pulley Spacer Sleeve 8PCS  | G2 Ankle Ring 1PC  | G3 Pulley Rope 6PCS  | G4 Pulley Sleeve 6PCS  | G5 Bushing (Ø16mm) 8PCS  | G6 Bushing (Ø29mm) 4PCS  | G7 Bushing (Ø50mm) 2PCS  |

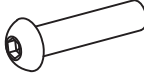
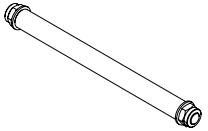
HARDWARE LIST

| | | | | |
|--|---|---|--|---|
| 1 Bolt (M6 x 12) 3PCS  | 2 Bolt (M8 x 16) 14PCS  | 3 Bolt (M10 x 20) 7PCS  | 4 Bolt (M10 x 25) 2PCS  | 5 Bolt (M10 x 45) 13PCS  |
| 6 Bolt (M10 x 70) 6PCS  | 7 Bolt (M10 x 85) 2PCS  | 8 Bolt (M10 x 175) 1PC  | 9 Bolt (M10 x 70) 6PCS  | 10 Bolt (M10 x 90) 6PCS  |
| 11 Sack protection cap (M16) 2PCS  | 12 Washer (M16) 2PCS  | 13 Washer (M6) 3PCS  | 14 Washer (M10) 71PCS  | 15 Washer (M8) 14PCS  |
| 16 Lock nut (M10) 37PCS  | 17 Lock nut (M16) 2PCS  | 18 Nut (M6) 3PCS  | 19 Bolt (M10 x 55) 3PCS  | 20 Double-Ended Bolt Set 1PC  |

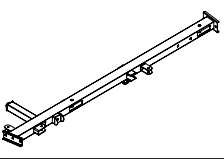
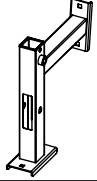
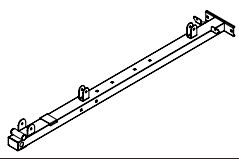
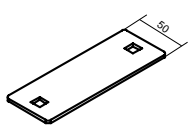
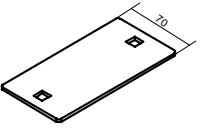
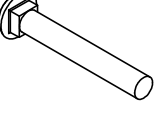
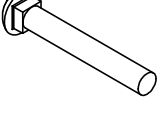
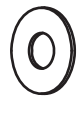
STEP 1:

| | | | | |
|---|---|---|---|---|
| A1 Front Upright 1PC  | A2 Seated Pad Connecting 1PC  | A3 Front Base 1PC  | C7 Connecting Plate 1PC  | C8 Connecting Plate B 2PCS  |
| 9 Bol t(M10 x 70) 4PCS  | 10 Bol t(M10 x 90) 2PCS  | 14 Washer (M10) 6PCS  | 16 Locknut (M10) 6PCS  | |

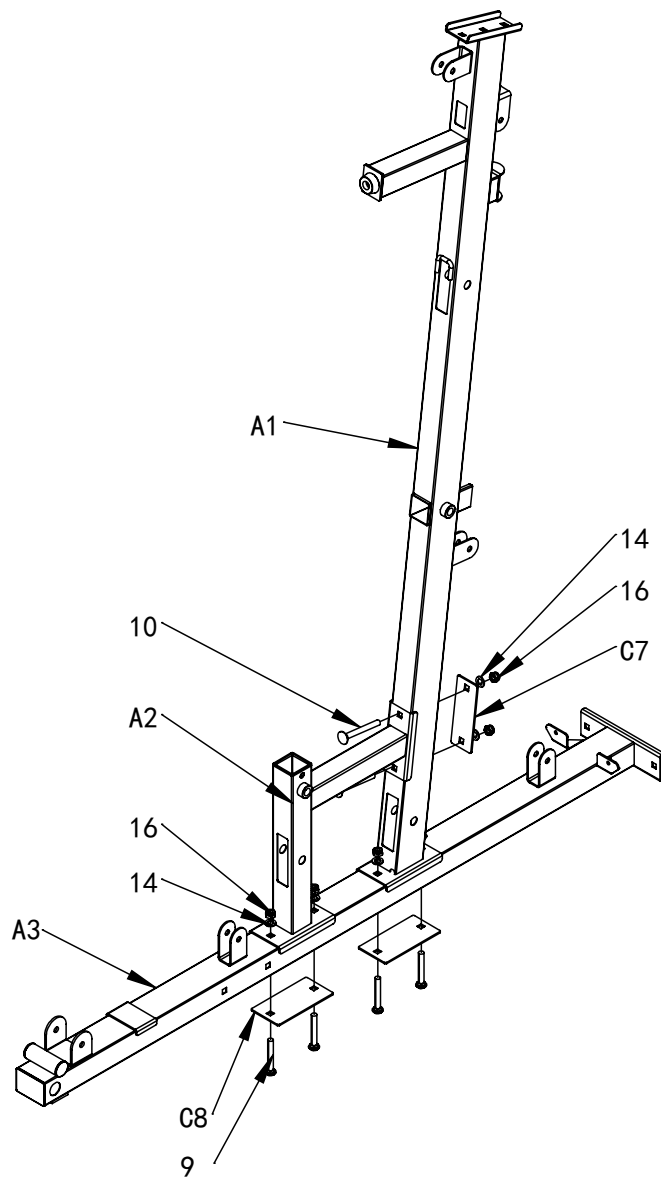

STEP 2:

A4 Guide Rod
2PCS

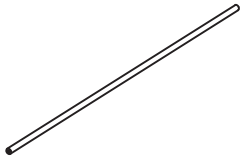

A5 Back Base
1PC

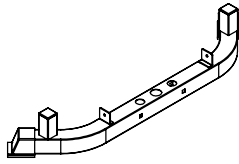

3 Bolt (M10 x 20)
2PCS





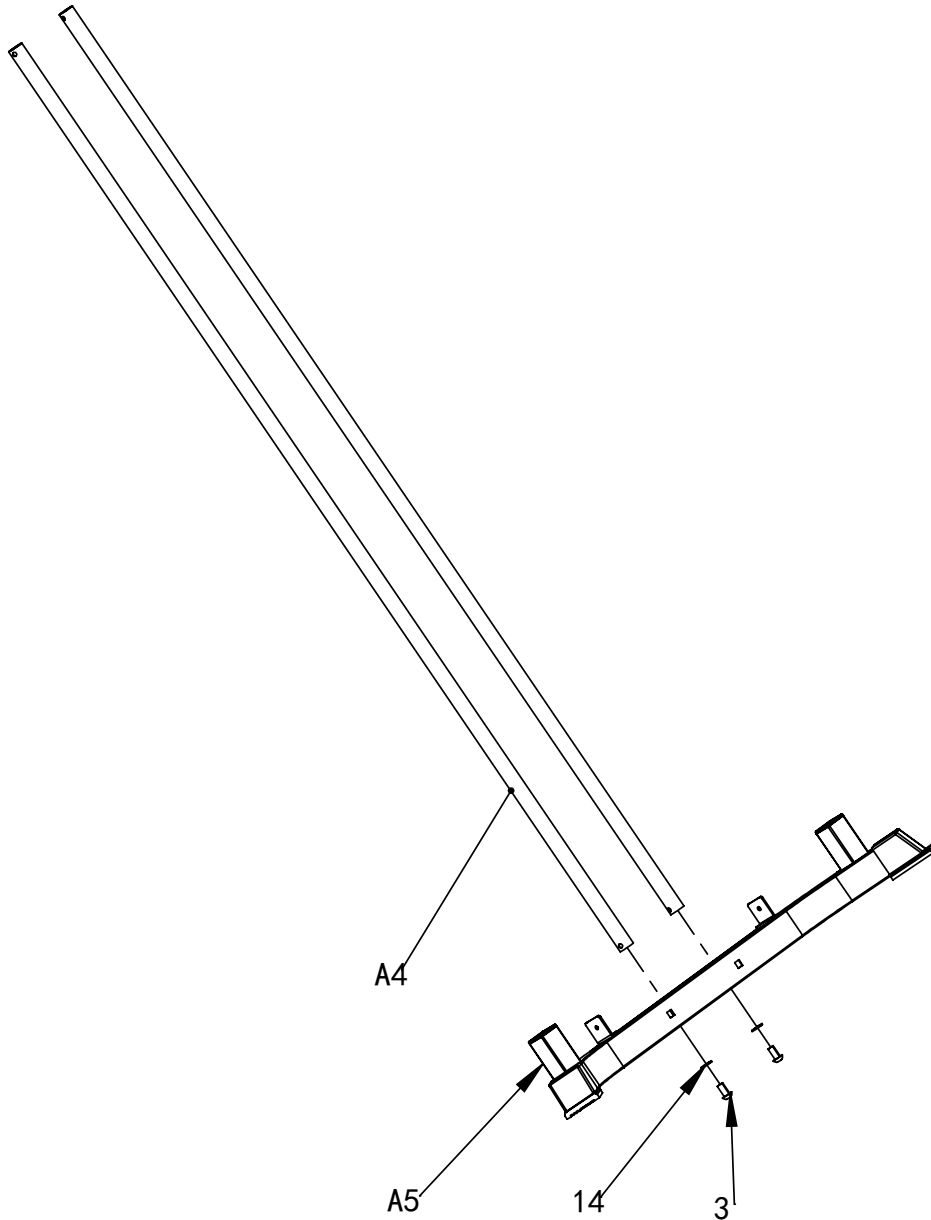

14 Washer (M10)
2PCS

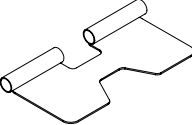
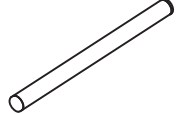
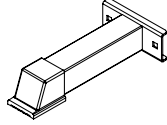
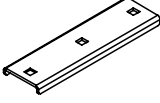

Tighten the screws in this step

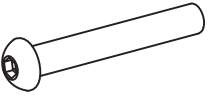
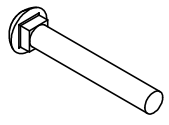
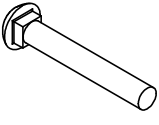
STEP 3:

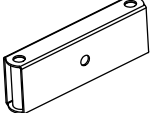
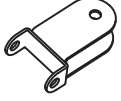
| | | | | |
|--|--|---|--|---|
| A6 Foot Pedal 1PC  | A7 Footboard Connecting Rod 1PC  | A8 Stable Base 2PCS  | C9 U Connecting Plate 1PC  | 3 Bolt(M10 x 20) 1PC  |
| 6 Bolt(M10 x 70) 2PCS  | 9 Bolt(M10 x 70) 2PCS  | 10 Bolt(M10 x 90) 2PCS  | 14 Washer(M10) 9PCS  | 16 Locknut(M10) 6PCS  |
| D6 Pulley Stand-A 1PC  | D5 Pulley Stand-B 2PCS  | | | |

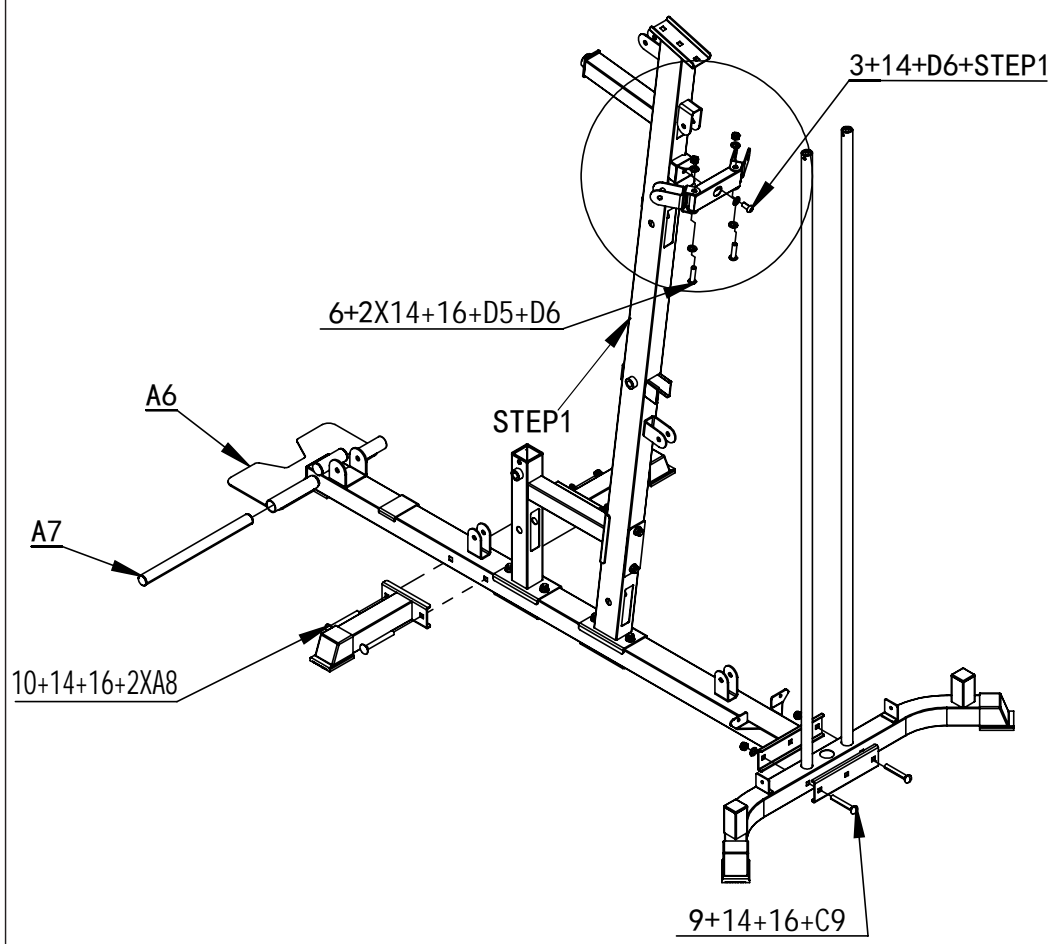
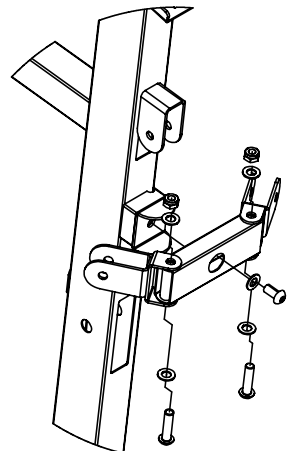

STEP 4:

A10 Weight Stack Pin
1PC



B1 Weight Stack Pin
1PC

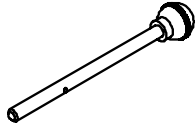

B3 Top Weight Stack
1PC

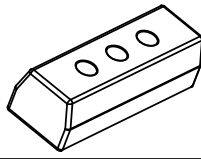

B4 Insert Lifting Rod
1PC

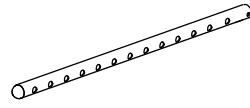

B5 Weight Stack Washer
1PC



B6 Weight Stack
12PCS

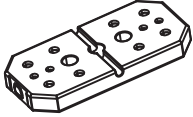

D1 Rubber Cushion Pad
2PCS

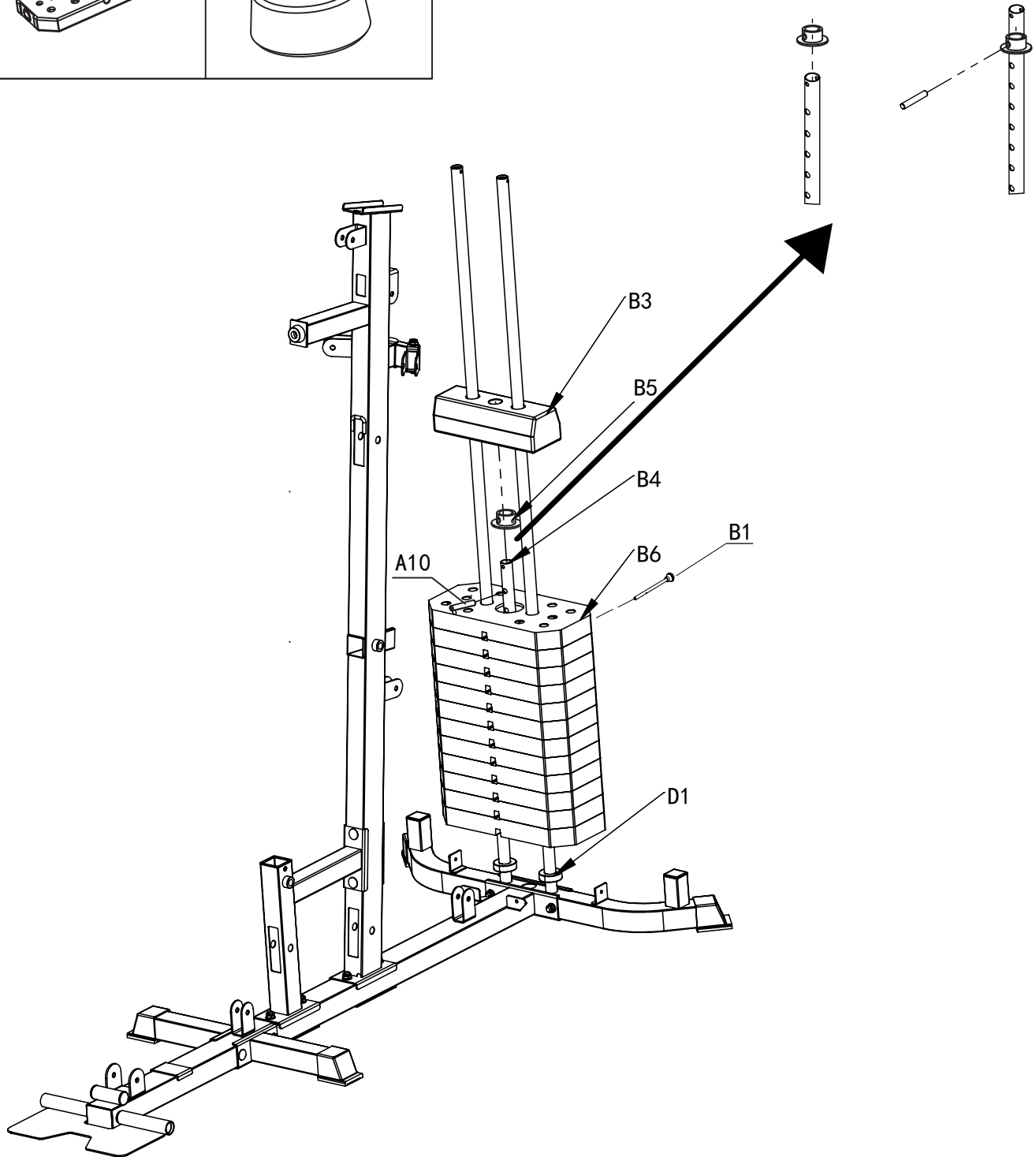
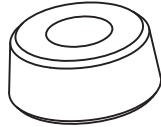

STEP 5:

B7 Top Frame
1PC

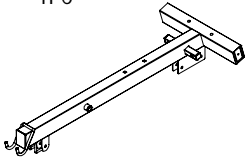

C7 Connecting Plate
1PC

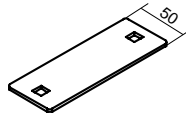

3 Bol t(M10 x 20)
2PCS



10 Bol t(M10 x 90)
2PCS

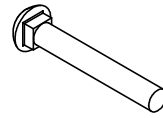

14 Washer (M10)
4PCS



16 Locknut (M10)
2PCS

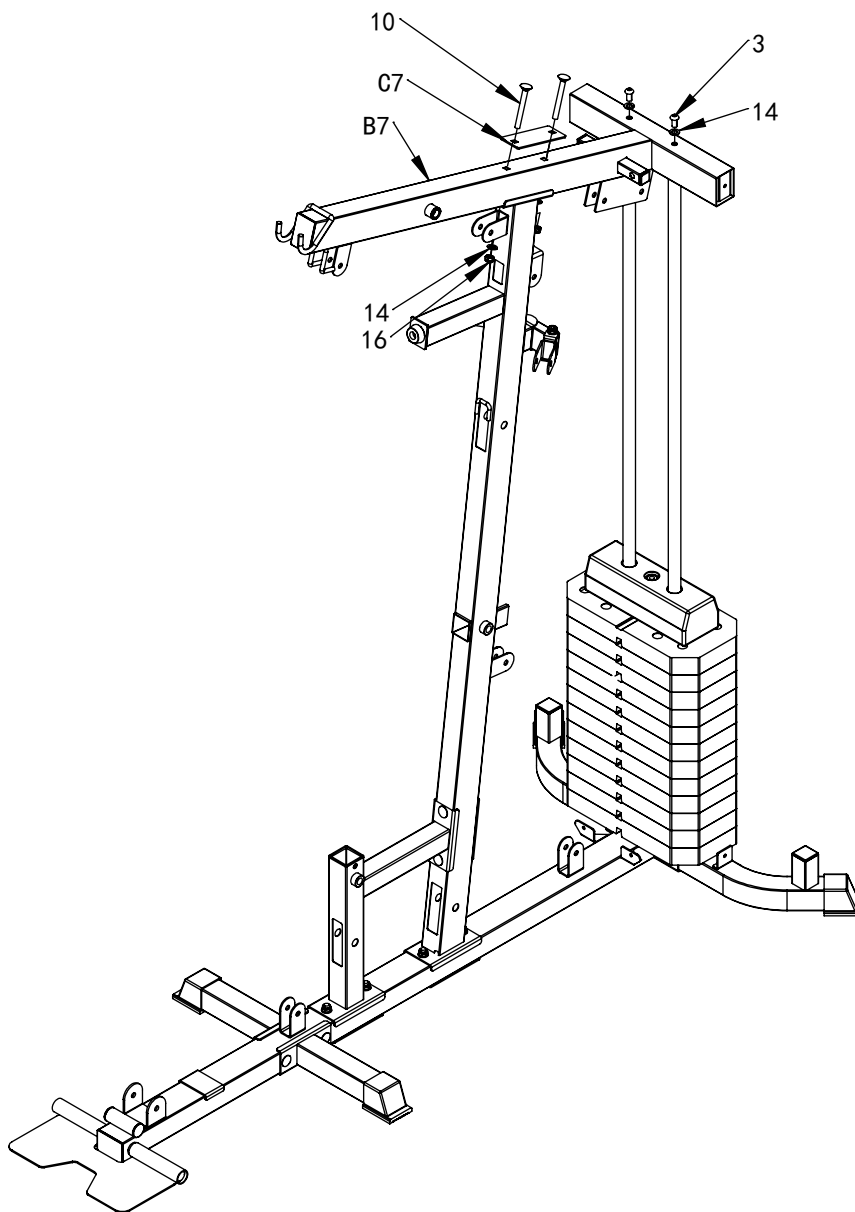

Do not tighten the screws before installing the guar

STEP 6.

B8 Jammer Arm Connecting
With G5, G6, 20
1PC

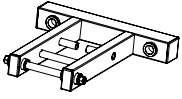







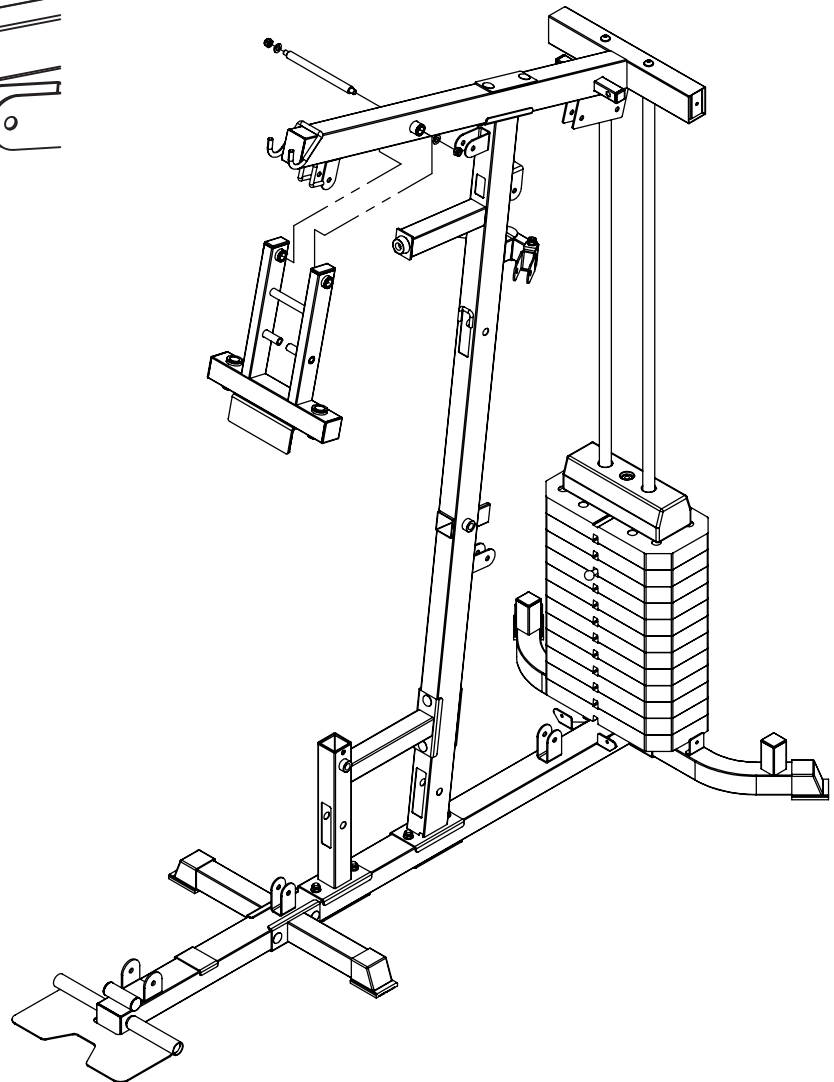
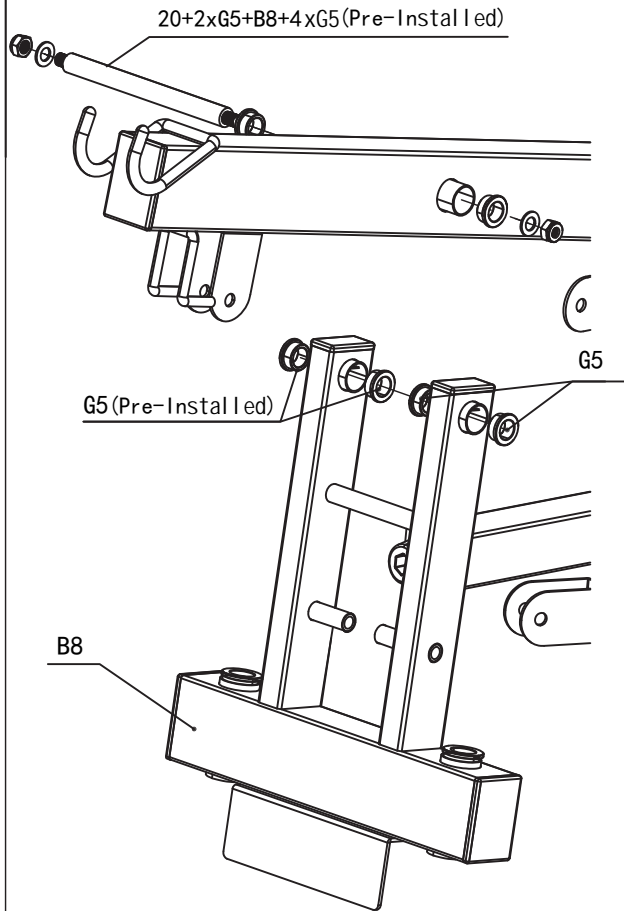
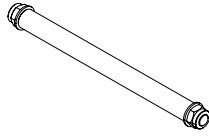

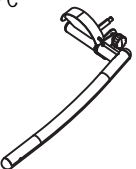
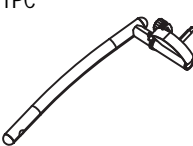

G5 Bushing (Ø16mm)
(Pre-Installed)
6PCS

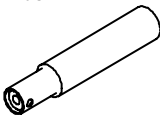

20 Double-Ended Bolt Set
1PC (Pre-Installed)

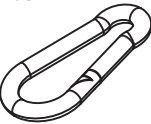



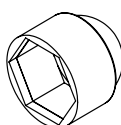

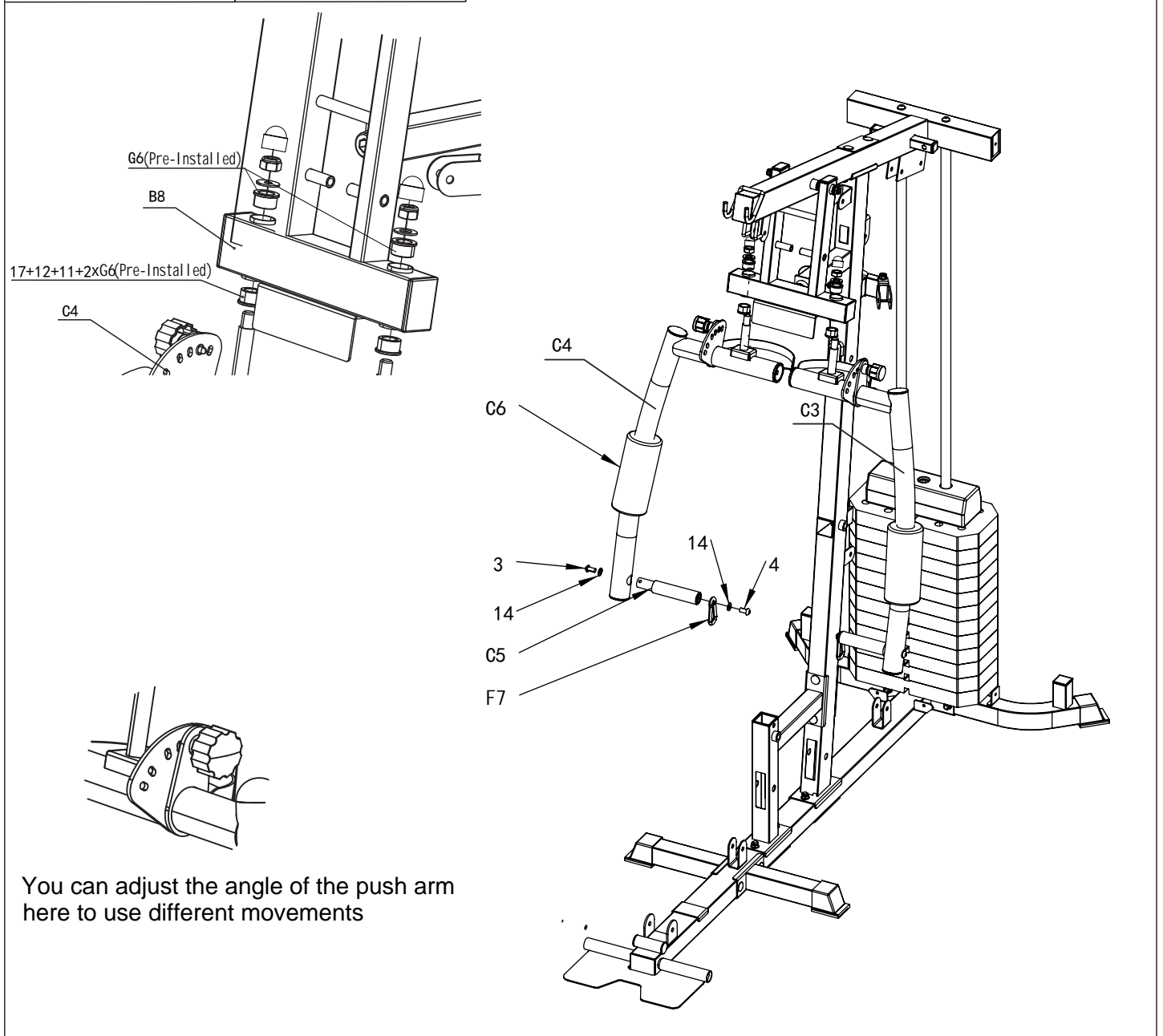

STEP 7:

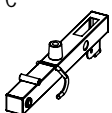
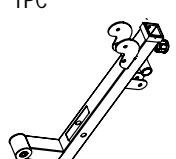
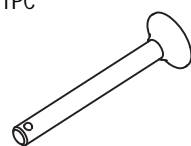
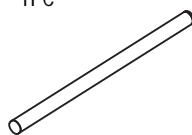
| | | | | |
|--|---|---|---|---|
| C3 Right Jammer Arm 1PC  | C4 Left Jammer Arm 1PC  | G6 Bushing (Ø29mm)(Pre-Installed) 4PCS  | 12 Washer (M16) 2PCS  | 17 Locknut (M16) 2PCS  |
| C5 Jammer Arm Handle 2PCS  | C6 Foam Sleeve 2PCS  | F7 Clip 2PCS  | 3 Bol t(M10 x 20) 2PCS  | 4 Bol t(M10 x 25) 2PCS  |
| 14 Washer (M10) 4PCS  | 11 Sack protection cap(M16) 2PCS  | | | |

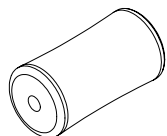
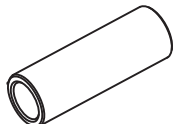
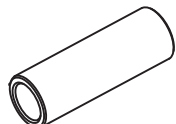
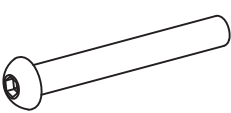

STEP 8:

| | | | | |
|---|--|--|--|---|
| B9 Leg Extension Arm 1PC  | B10 Front Insert Tube 1PC  | C10 Locking Pin 1PC  | D2 Foam Sleeve Roller(433mm) 1PC  | D3 Foam Sleeve Roller(400mm) 1PC  |
| D4 Foam Plug 4PCS  | E6 Foam Sleeve 4PCS  | E9 Roller A(60mm) 1PC  | E10 Roller B (63mm) 1PC  | 7 Bolt(M10 x 85) 1PC  |
| 14 Washer (M10) 2PCS  | 16 Locknut (M10) 1PC  | G5 Bushing (∅16mm) (Pre-Installed) 2PCS  | G7 Bushing (∅50mm) (Pre-Installed) 2PCS  | |

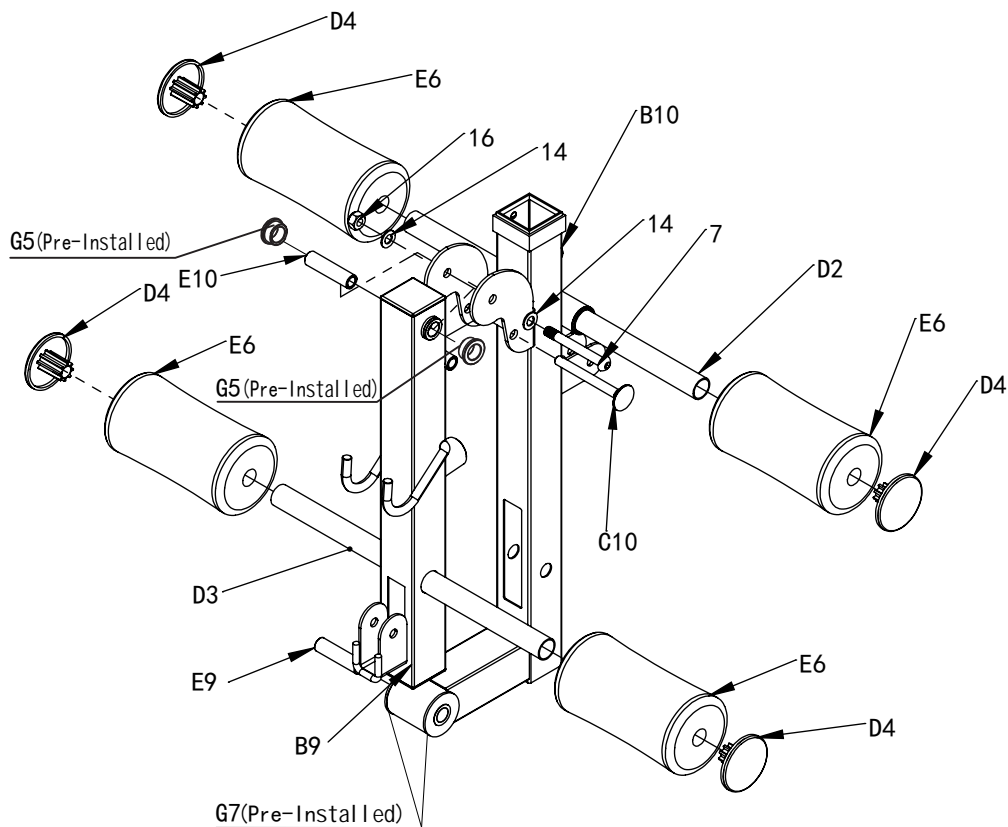

STEP 9:

7 Bolt (M10 x 85)
1PC

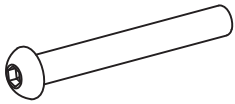





14 Washer (M10)
2PCS

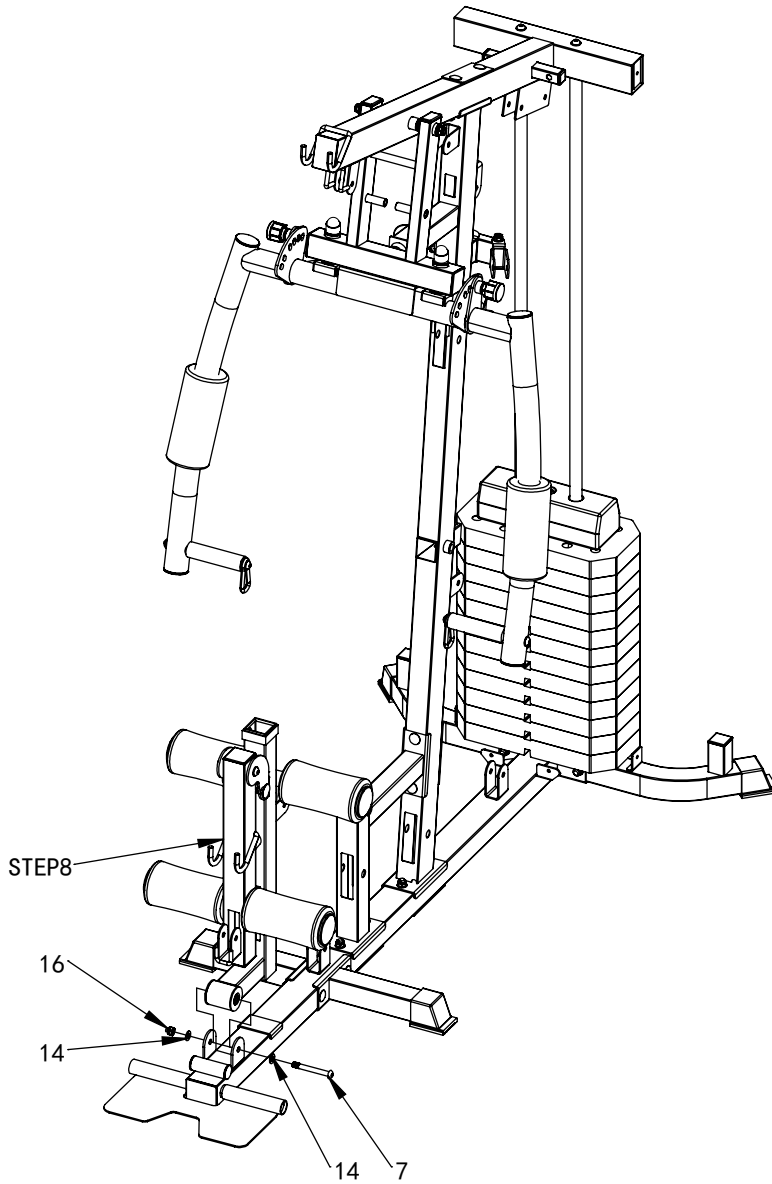

16 Locknut (M10)
1PC

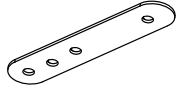
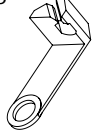

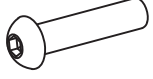
STEP 10:

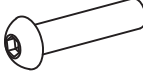
| | | | | |
|---|---|---|--|---|
| F1 Pulley 2PCS  | E2 Pulley Stand-D 2PCS  | G3 Pulley Rope 2PCS  | G4 Pulley Sleeve 2PCS  | 19 Bol t (M10 x55) 1PC  |
| 14 Washer (M10) 4PCS  | 16 Locknut (M10) 2PCS  | 5 Bol t (M10 x45) 1PCS  | | |

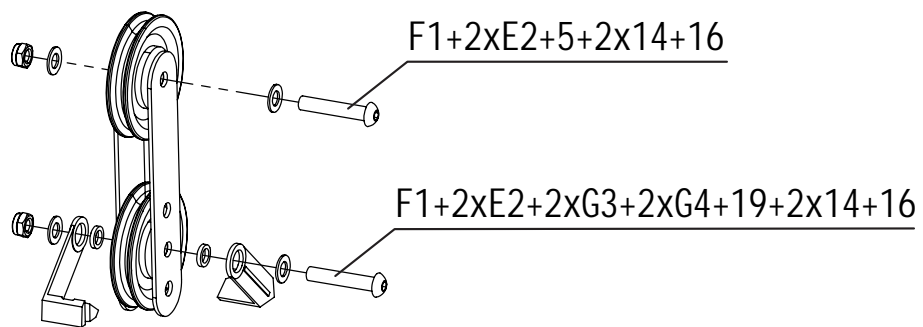

STEP 11:

14 Washer (M10)
12PCS



F1 Pulley
6PCS



16 Locknut (M10)
6PCS



5 Bol t (M10 x45)
5PCS

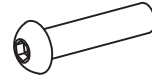

8 Bol t (M10 x 175)
1PC

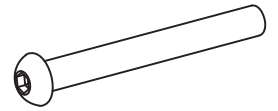

F1+5+2X14+16

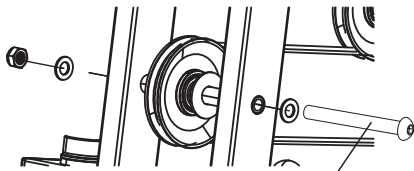

F1+8+2X14+16

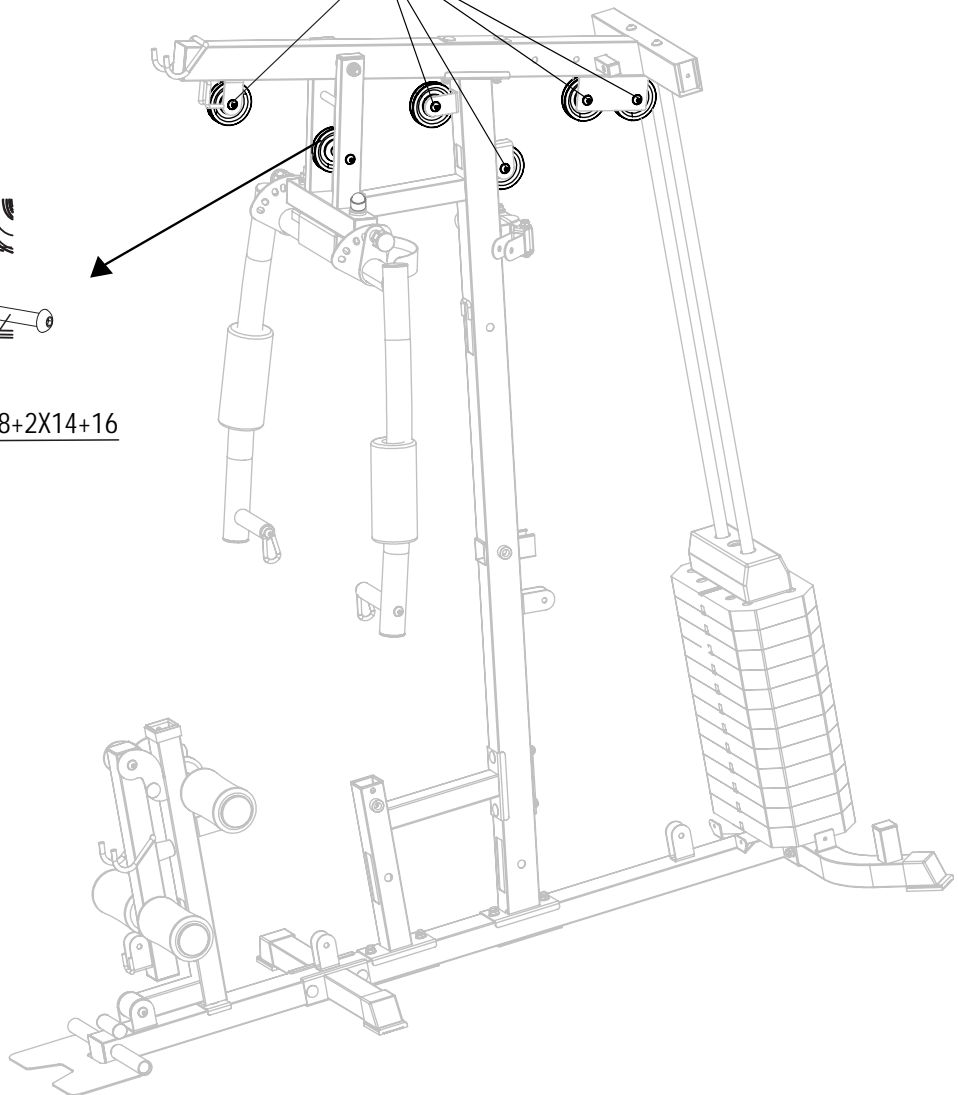

STEP12:

F2 Cable A (2980mm)
1PC

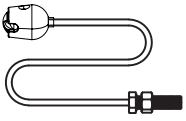

B2 Weight Washer
1PC





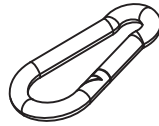

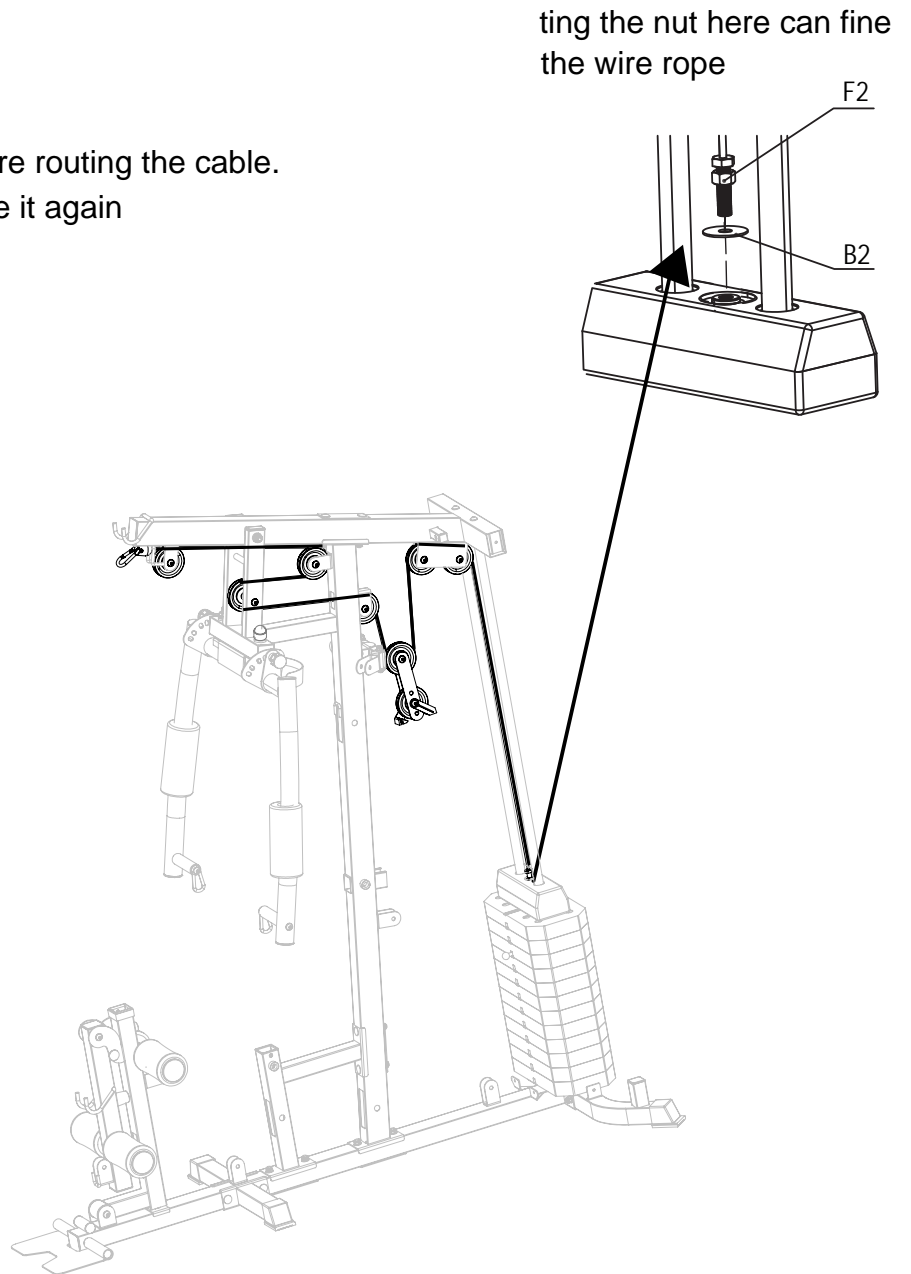
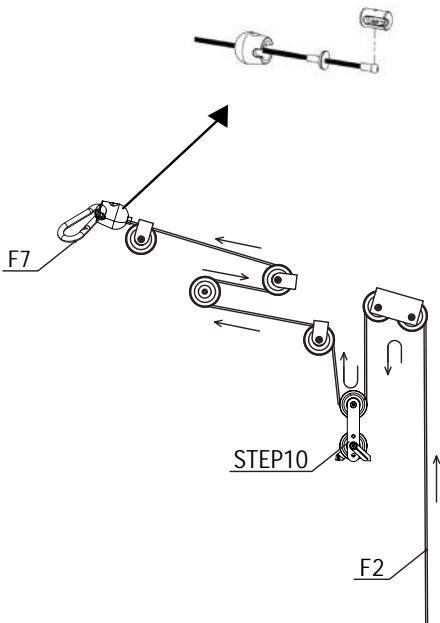

F7 CLi p
1PC

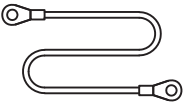

Remove the cable connector before routing the cable.
After installing the cable, assemble it again

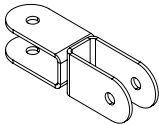
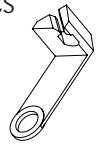

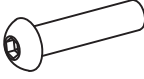
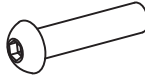



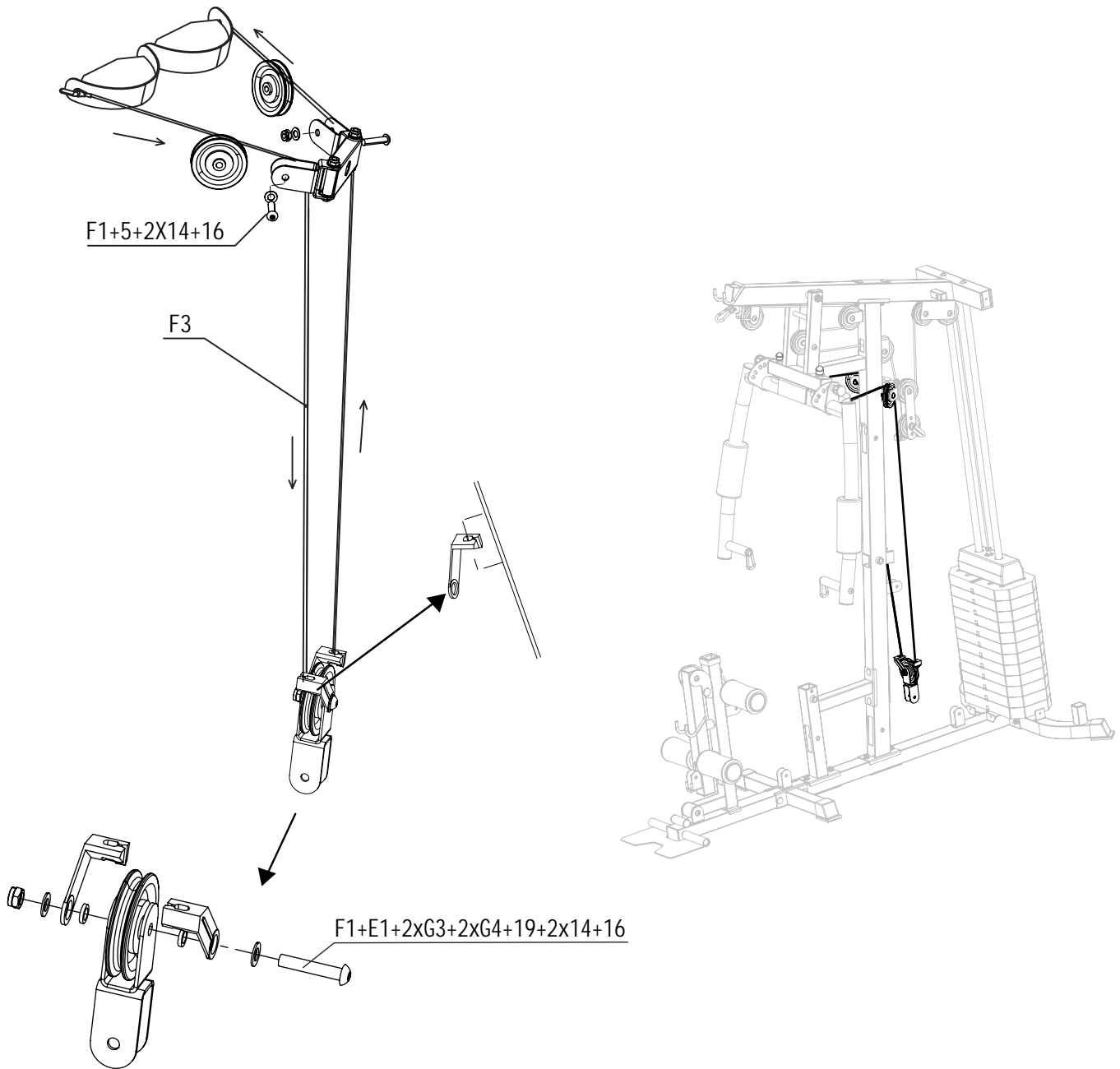

STEP 13 :

| | | | | |
|--|--|--|--|--|
| F3 Cable B (2970mm) 1PC  | F1 Pulley 3PCS  | E1 Pulley Stand-C 1PC  | G3 Pulley Rope 2PCS  | G4 Pulley Sleeve 2PCS  |
| 19 Bolt (M10 x55) 1PC  | 5 Bolt (M10 x45) 2PCS  | 14 Washer (M10) 6PCS  | 16 Locknut (M10) 3PCS  | |

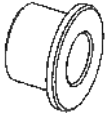

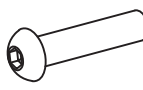
Please install the rope and pulley at the same time

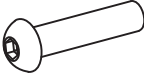
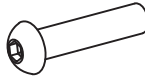
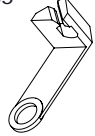
STEP 14 :

| | | | | |
|---|---|---|--|---|
| G1 Pulley Spacer Sleeve 8PCS  | F1 Pulley 10PCS  | 5 Bol t (M10 x45) 5PCS  | 14 Washer (M10) 20PCS  | 16 Locknut (M10) 10PCS  |
| 19 Bol t (M10 x55) 1PC  | 6 Bol t (M10 x70) 4PCS  | G3 Pulley Rope 2PCS  | G4 Pulley Sleeve 2PCS  | |

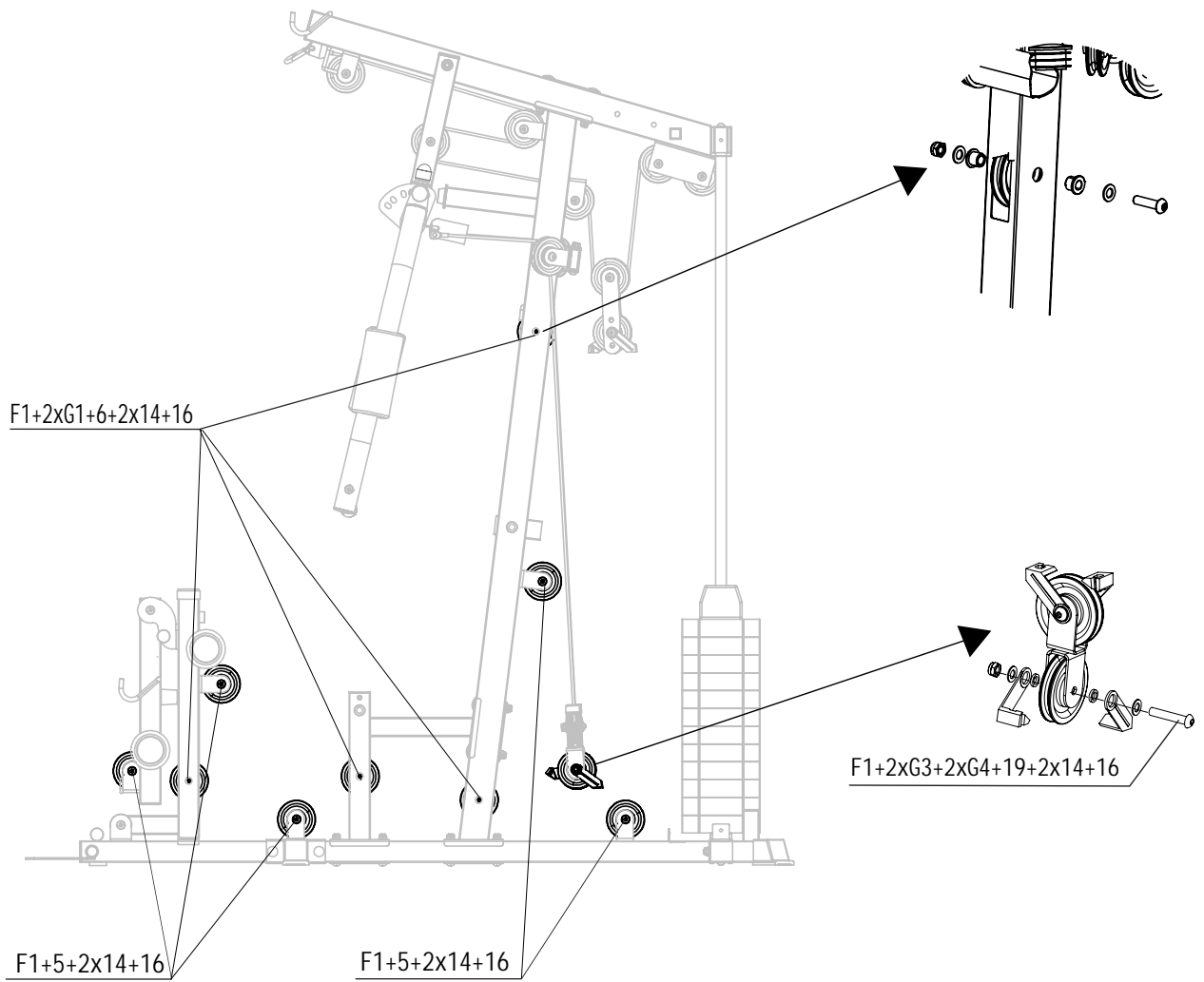

STEP 15:

F4 Cable C (5065mm)
1PC

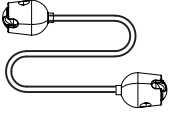

Remove the cable connector before routing the cable.
After installing the cable, assemble it again

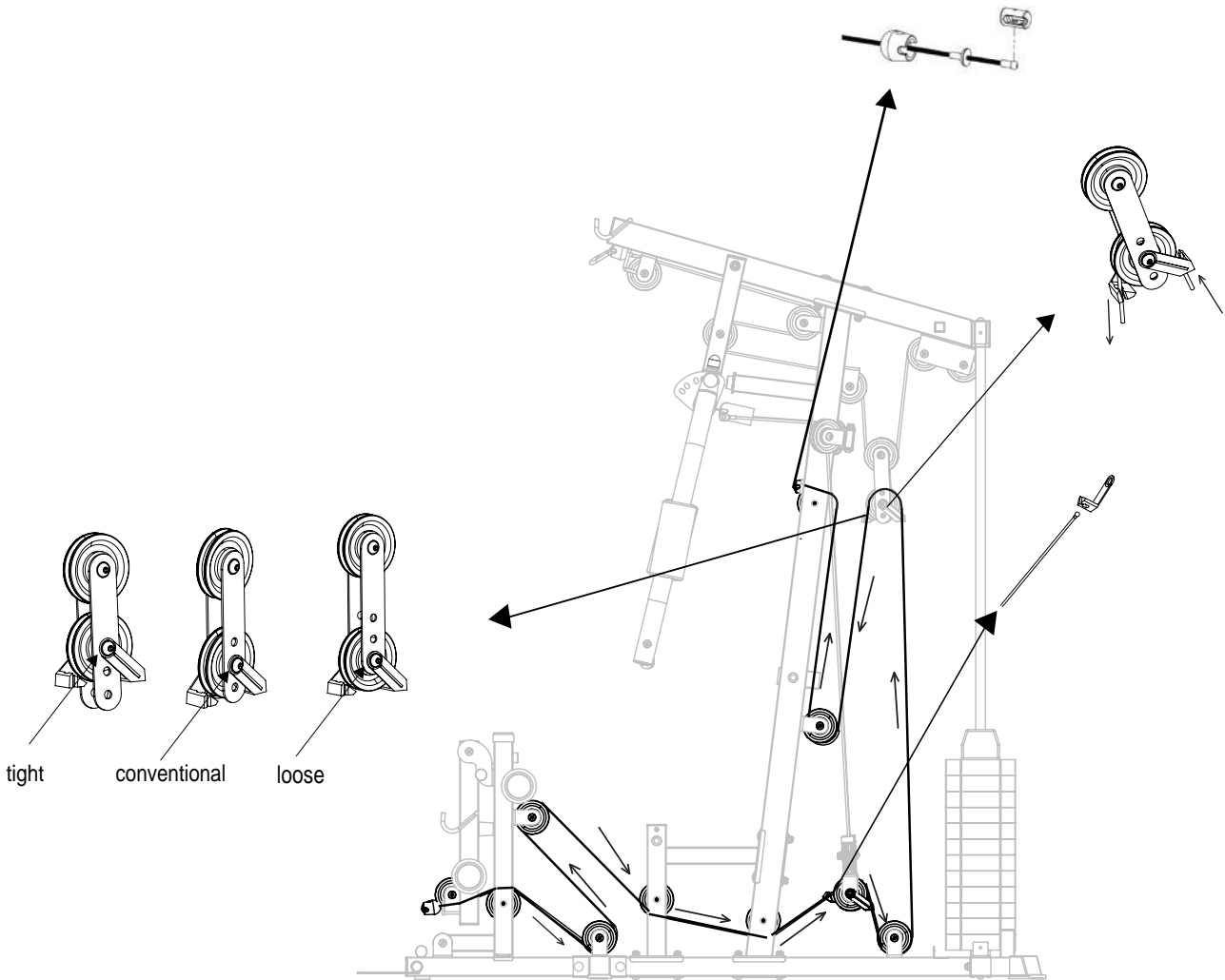

Adjust these pulley brackets and two wheels
Sub-spacing allows for simultaneous adjustment of steel wires
Roughly adjust the length of the rope and increase the spacing
Reducing the spacing means tightening the steel wire rope

STEP 16 :

E7 Right Shell
1PC

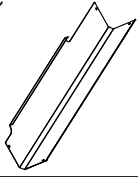

E8 Left Shell
1PC

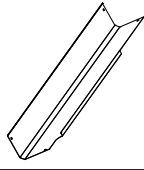

2 Bol t (M8 x16)
8PCS



15 Washer (M8)
8PCS



13 Washer (M6)
3PCS





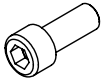

1 Bol t (M6 x 12)
3PCS

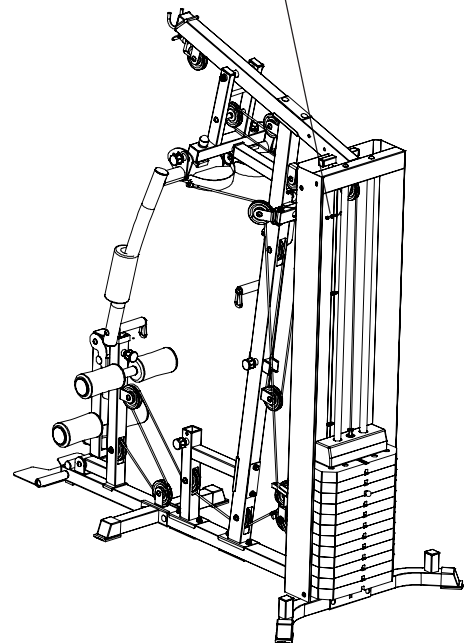
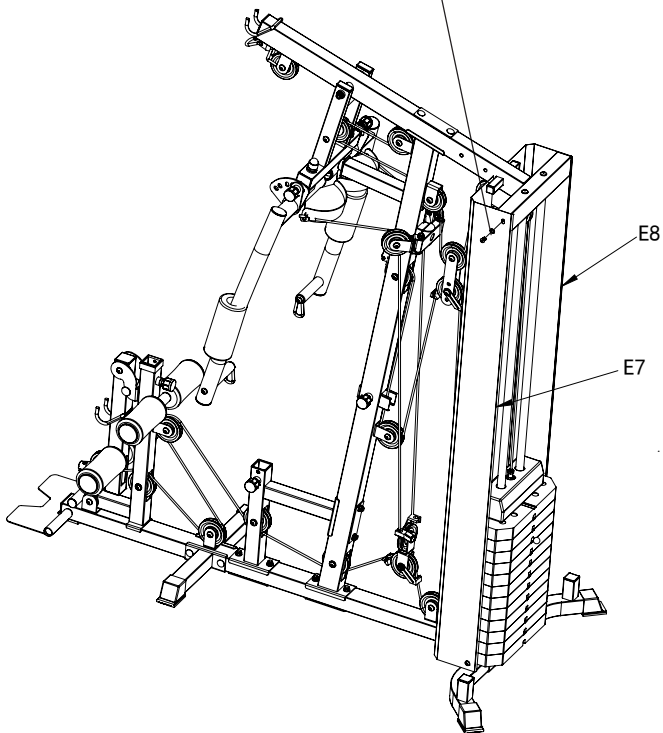
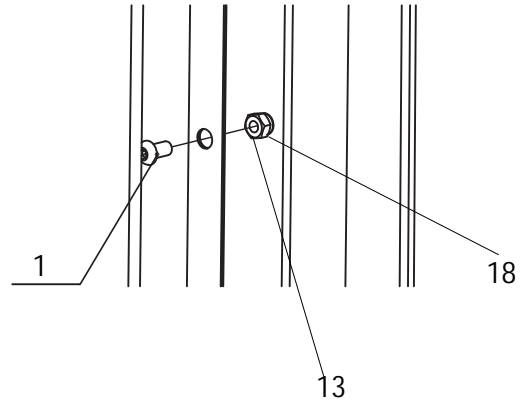
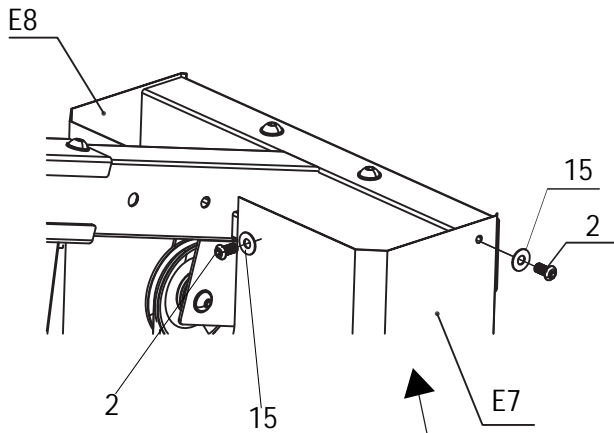

18 Nut (M6)
3PCS

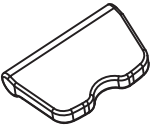

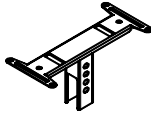
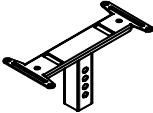

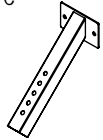

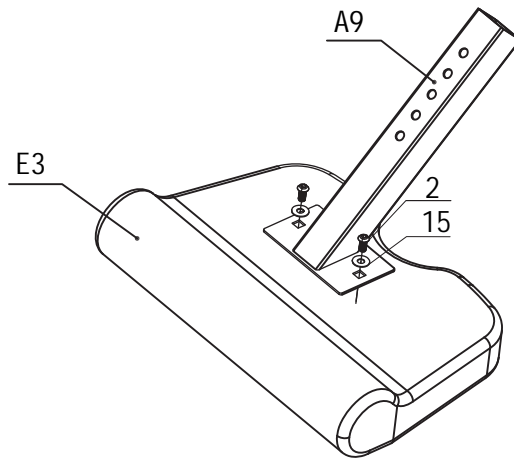
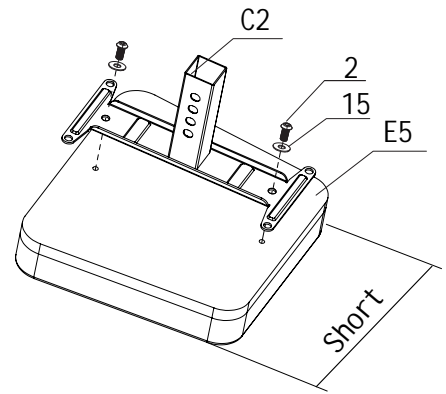
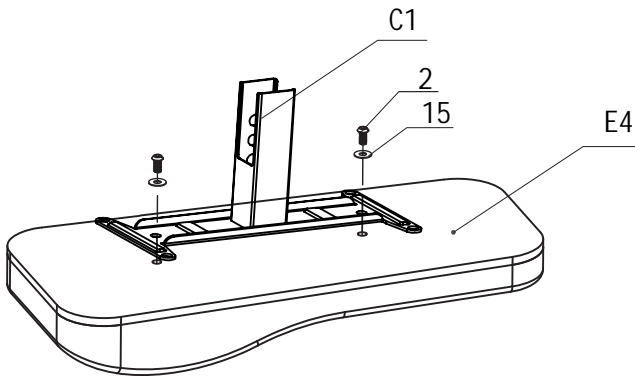

STEP 17:

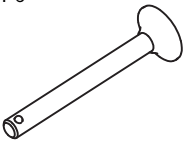
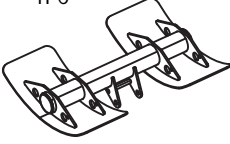
| | | | | |
|---|---|---|--|---|
| E3 Preacher Pad 1PC  | E4 Back Pad 1PC  | E5 Seated Pad 1PC  | C1 Back Pad Connecting 1PC  | C2 Seat Pad Connecting 1PC  |
| 2 Bol t(M8 x16) 6PCS  | 15 Washer(M8) 6PCS  | A9 Preacher Pad Connecting 1PC  | | |

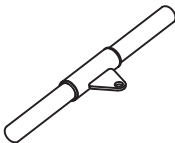
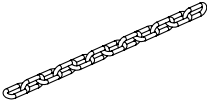
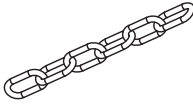

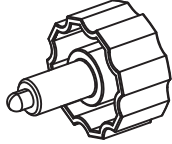
STEP 18 :

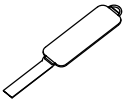
| | | | | |
|--|---|--|--|---|
| C10 Locking Pin 1PC  | D7 Leg Press Pedal 1PC  | D8 Leg Press Pedal Connecting 1PC  | D9 Lat Pull Down Bar 1PC  | D10 Short Straight Bar 1PC  |
| F5 Chain (12) 1PC  | F6 Chain (6) 1PC  | F7 Clip 4PCS  | F8 Knob 3PCS  | F9 Tri cep Rope 1PC  |
| F10 Cable Handle 2PCS  | G2 Ankle Ring 1PC  | | | |

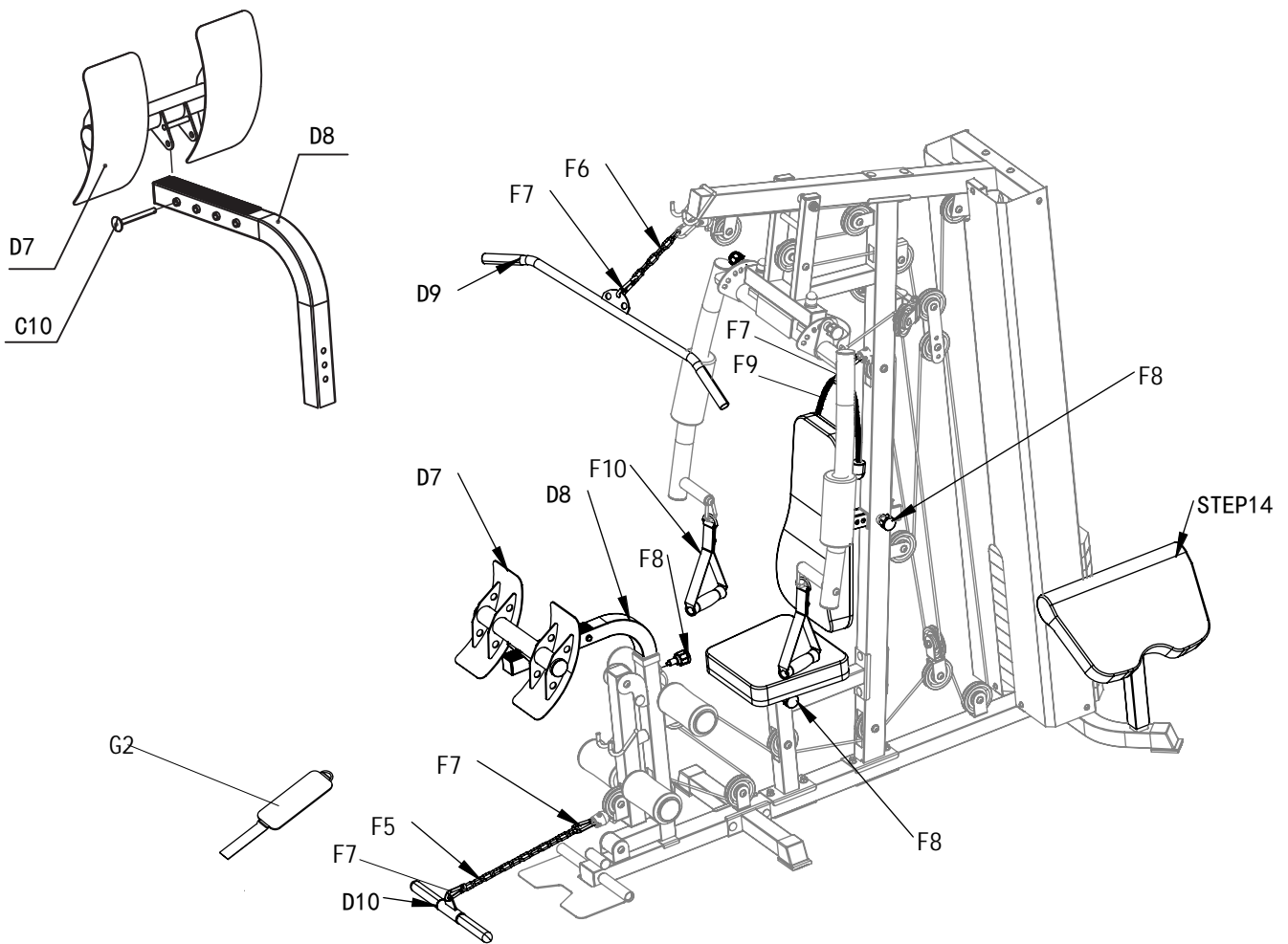

FORMAT OF AFTER-SALE EMAIL

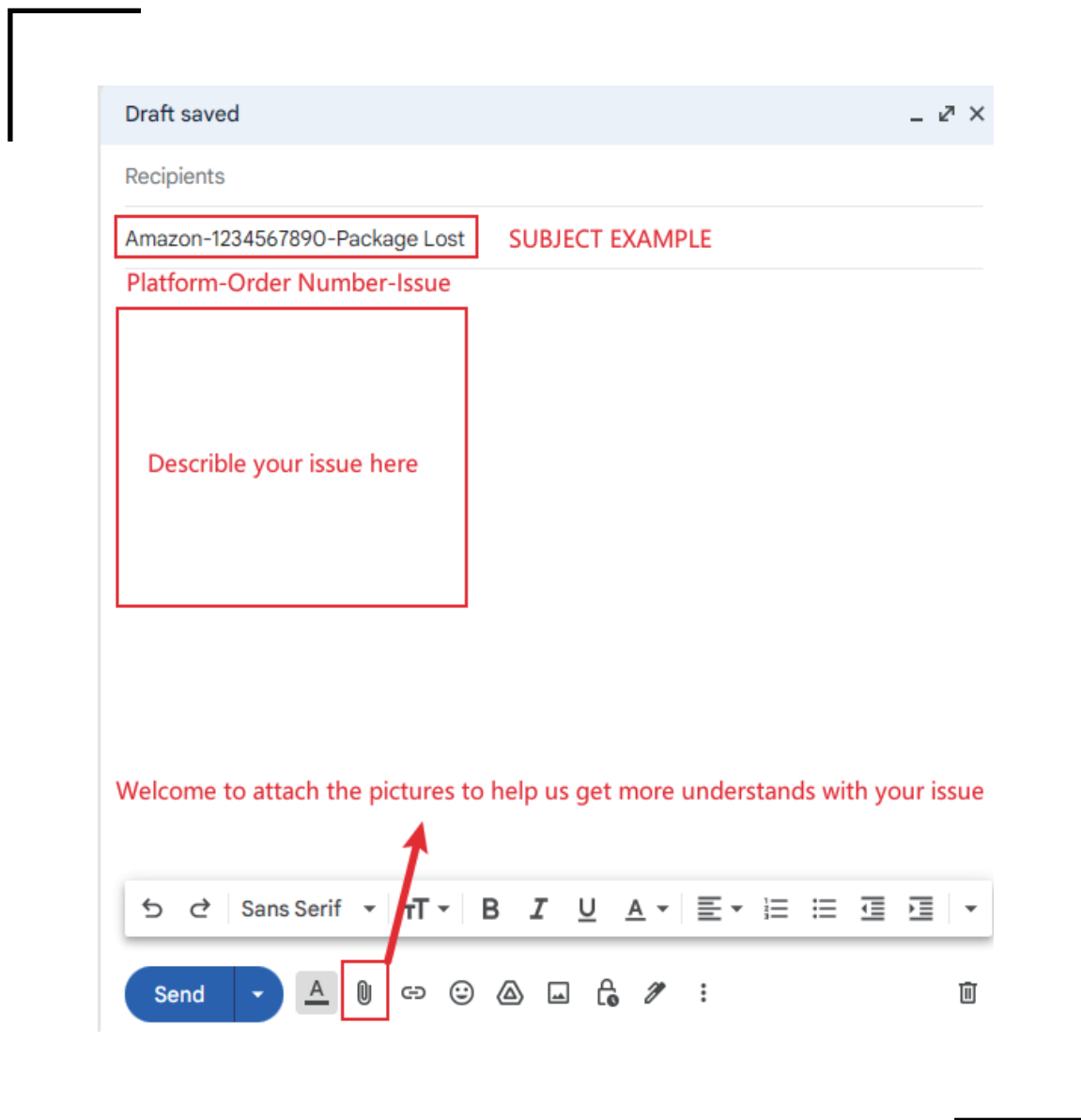

Welcome to send us some pictures to describe your problem, which will help us better and faster understand your current situation, and thus provide you with the best solution.

The machine you ordered has been carefully inspected and is fully guaranteed to be in perfect working order.

This lifetime warranty covers missing parts, damaged parts, package lost, all manufacturing and mechanical defects, excluding malfunctions or deterioration resulting from accidents or negligence. with this card, you are entitled to obtain service at any platform, such as Amazon, Walmart, and our own website.

Please provide your Platform and Order Number to us in the email subject.

**NEED HELP?
CONTACT US FIRST.**

support@gmwdfitness.com