

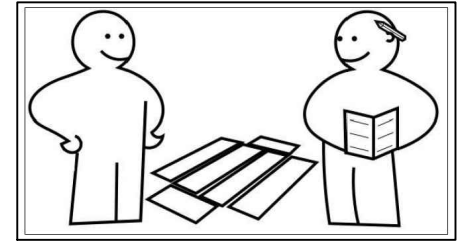

ASSEMBLY INSTRUCTION

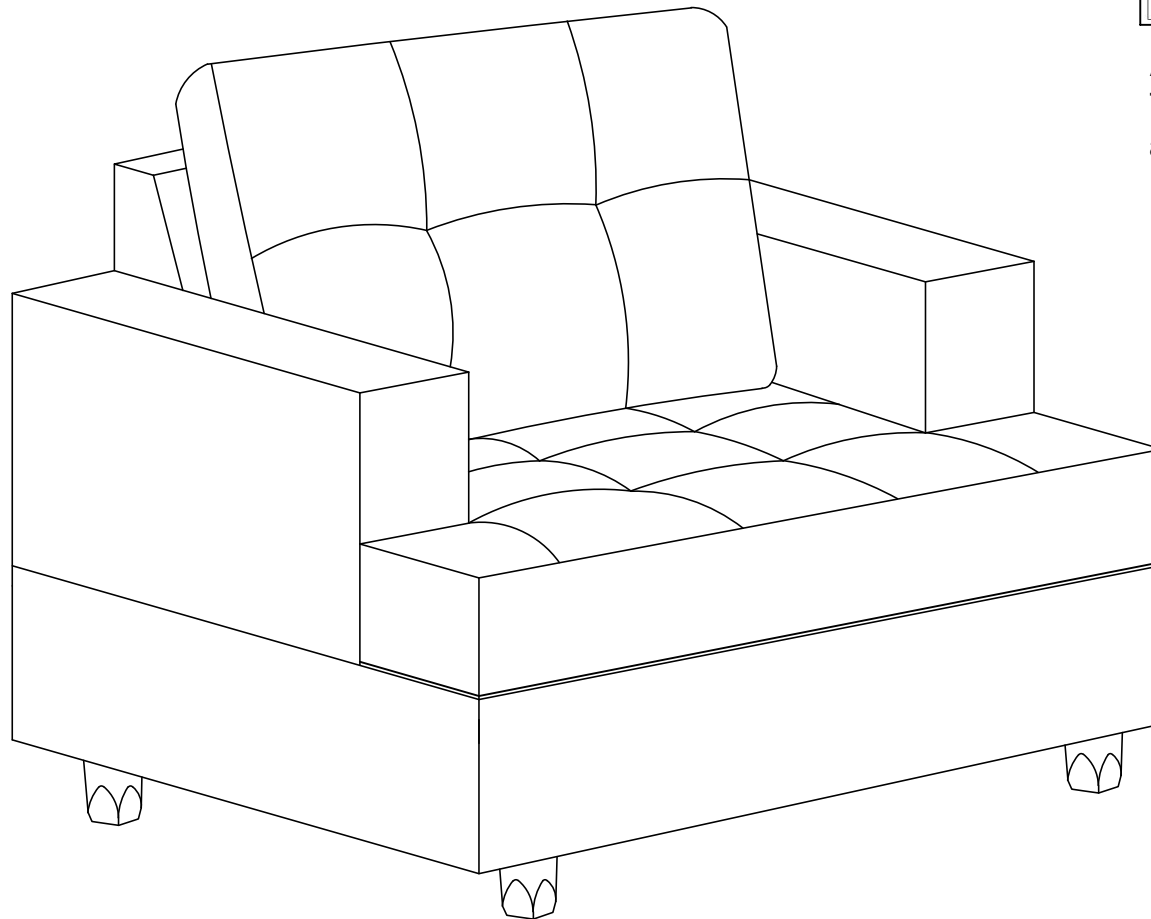

Attention:
Two people are required for
assembly and lifting unit.

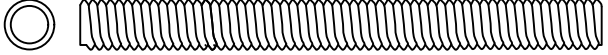
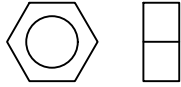
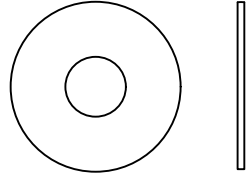

HARDWARE LIST

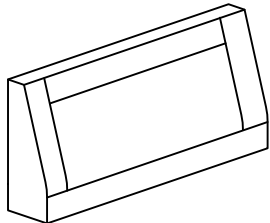
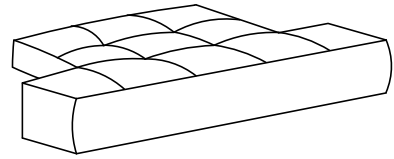
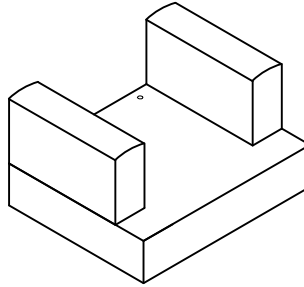
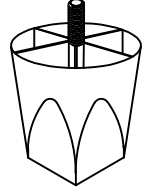
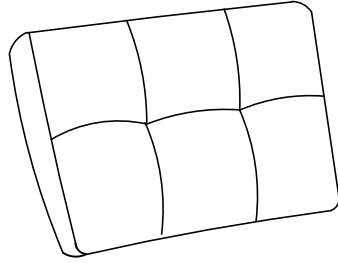
			
<p>A</p>	<p>2PCS</p>	<p>C</p>	
<p>Threaded Rod 5/16 x 75mm</p>		<p>Nut 5/ 16 x 12mm</p>	
		<p>1 : 1</p> 	<p>P1</p>  <p>BACK REST (1PC)</p>
<p>D</p>	<p>1PC</p>	<p>P2</p>  <p>CUSHION SEAT (1PC)</p>	
<p>Spanner</p>		<p>P4</p>  <p>SEAT BASE(1PC)</p>	<p>P5</p>  <p>PLASTIC LEG (4PCS)</p>
<p>P3</p>  <p>BACK CUSHION (1PC)</p>			

ASSEMBLY INSTRUCTION

STEP 1.
Remove all part and hardware from box.

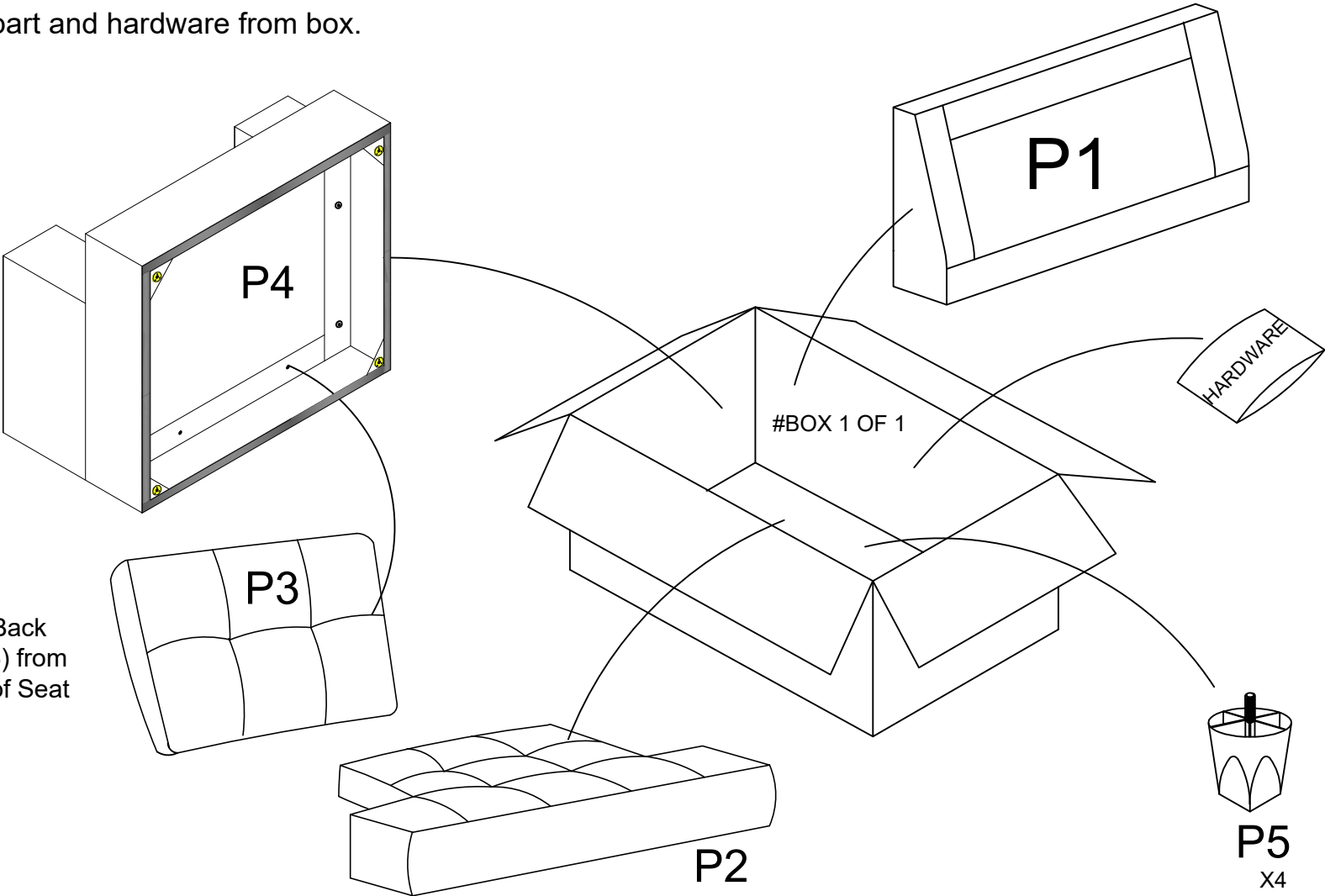



** Remove Back
Cushion (P3) from
the bottom of Seat
Base (P4).

ASSEMBLY INSTRUCTION

STEP 2.

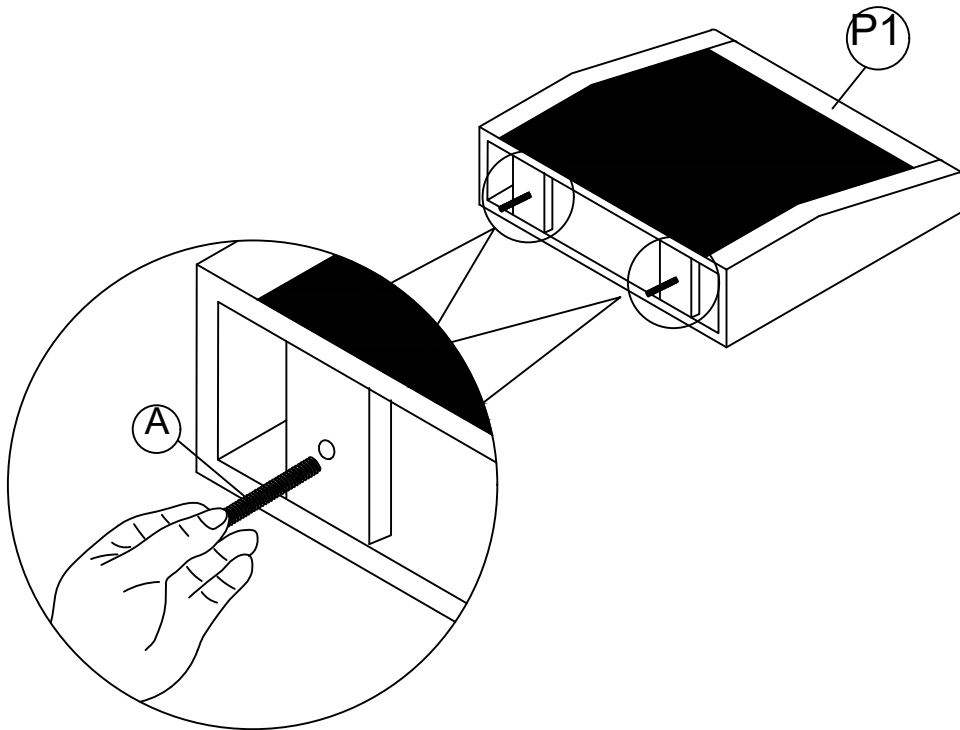
Attached the Threaded Rod (A) (2pcs) to Back Rest (P1)(1pc).

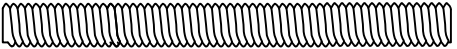

	
A	2PCS
Threaded Rods 5/16 x 75mm	

STEP 3.

Attached the Back Rest (P1) to the Seat Base (P4)(1pc).

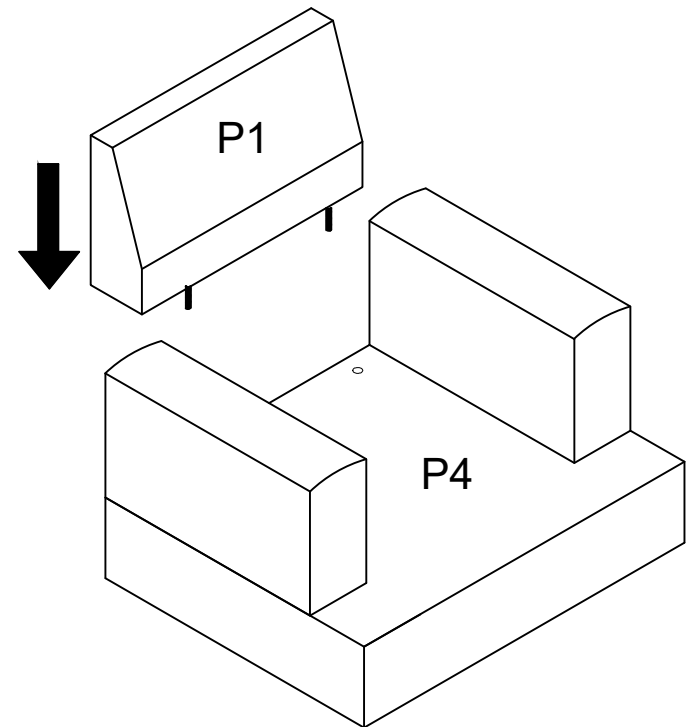

ASSEMBLY INSTRUCTION

STEP 4.

Attached the Back Rest (P1) to Seat Base (P4) (1pc).

Used Flat Washer (C) (2pcs), Nut (B)(2pcs) and Spanner(D) to assemble.

Make sure the bolts are fully tighten and secure.

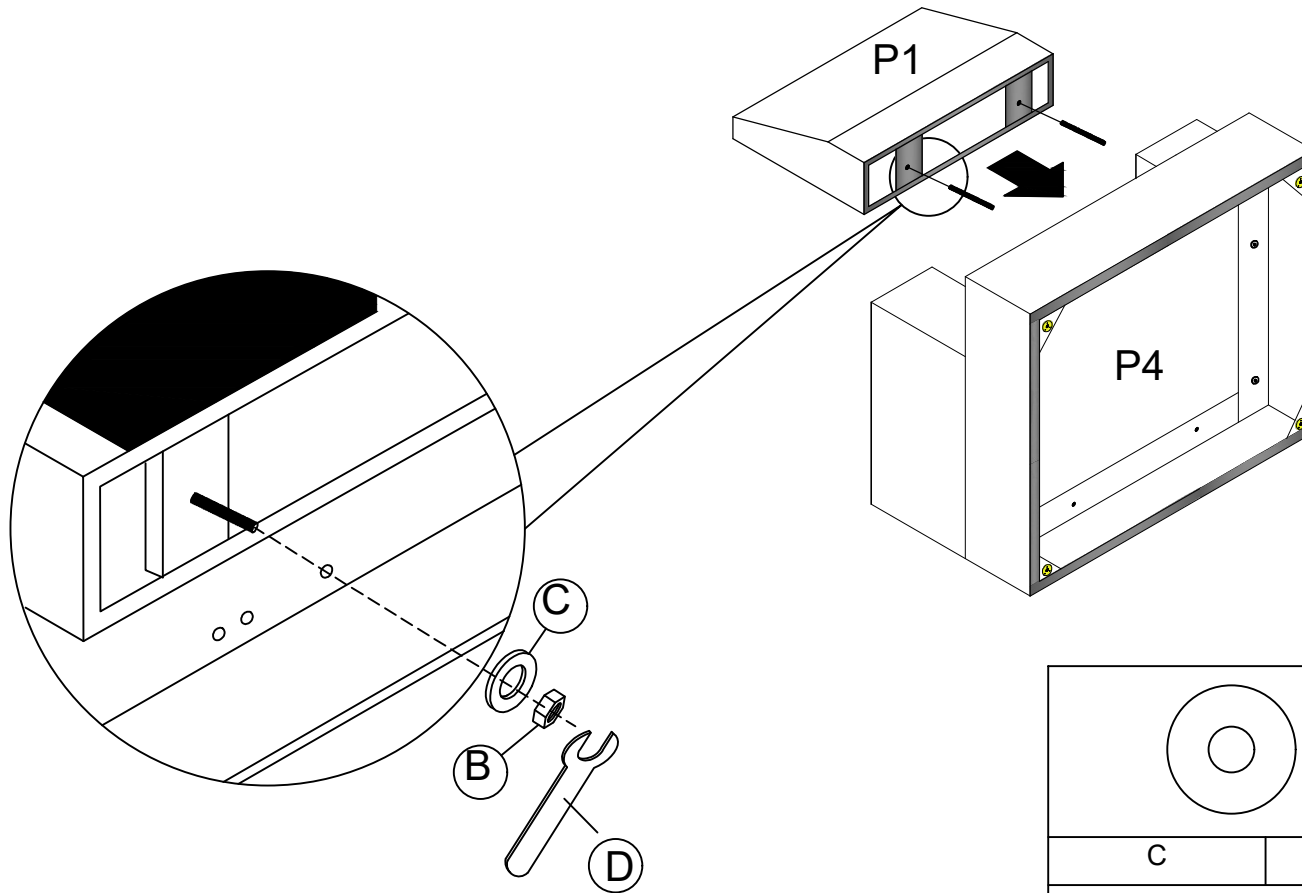

ASSEMBLY INSTRUCTION

STEP 5.

Closed cover cloth with velcro.

Attached Plastic Leg (P5) (4pcs) to Seat Base (P4) (1pc). Legs should be tightened.

P5



PLASTIC LEG (4PCS)

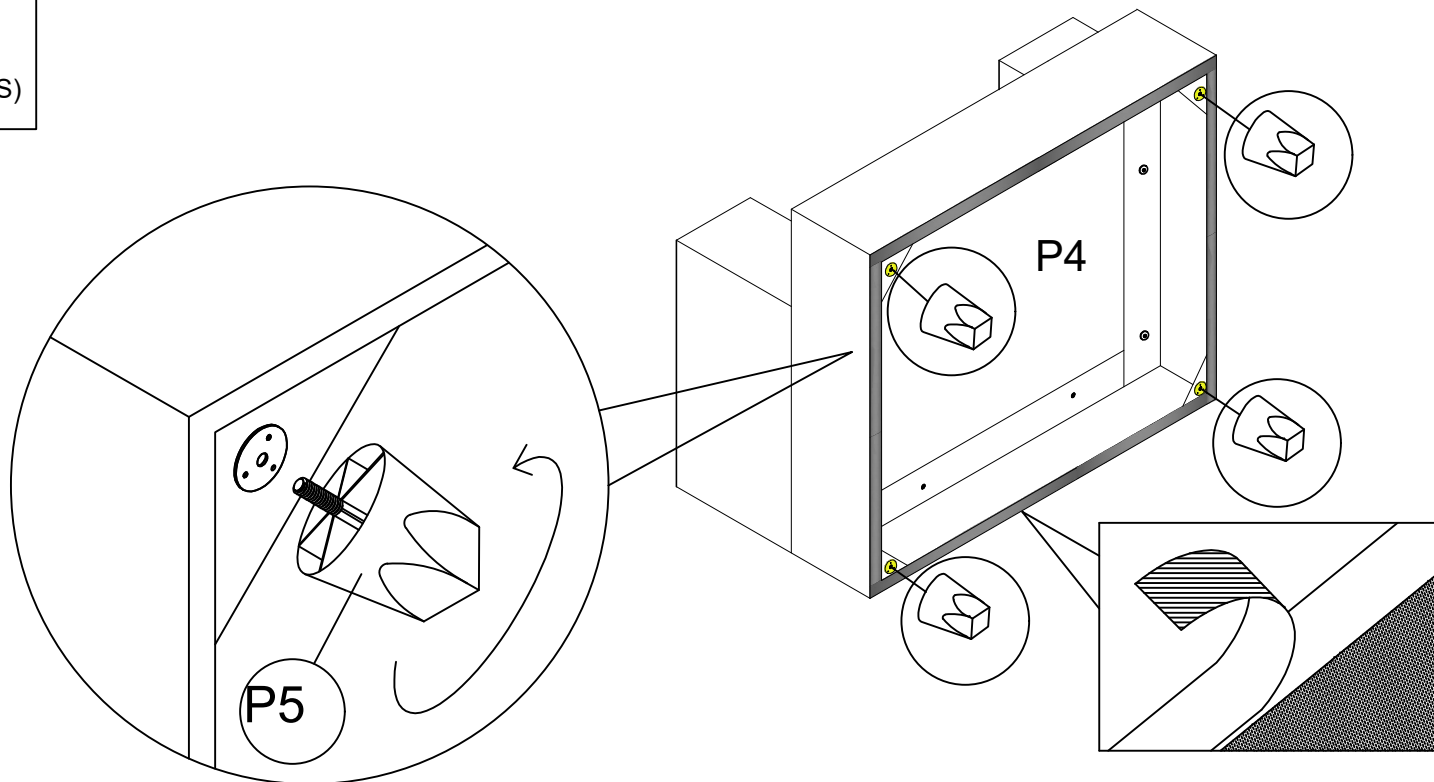

ASSEMBLY INSTRUCTION

STEP 6.

Attach the Cushion Seat (P2) (1pc), Back Cushion (P3) (1pc) to the seat base.

