

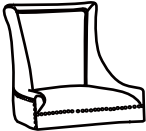





ASSEMBLY INSTRUCTIONS

Ax1	 Seat
Bx2	 Front leg
Cx2	 Back leg
Dx2	 Adjust the foot
Ex4	 Screw M8*60mm
Fx4	 Screw M8*50mm
Gx8	 Spring washer M8
Hx8	 Flat washer M8*22mm
Ix1	 Allen key M8

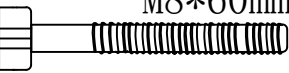

WARNING:

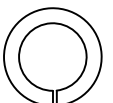
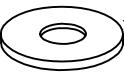
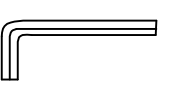
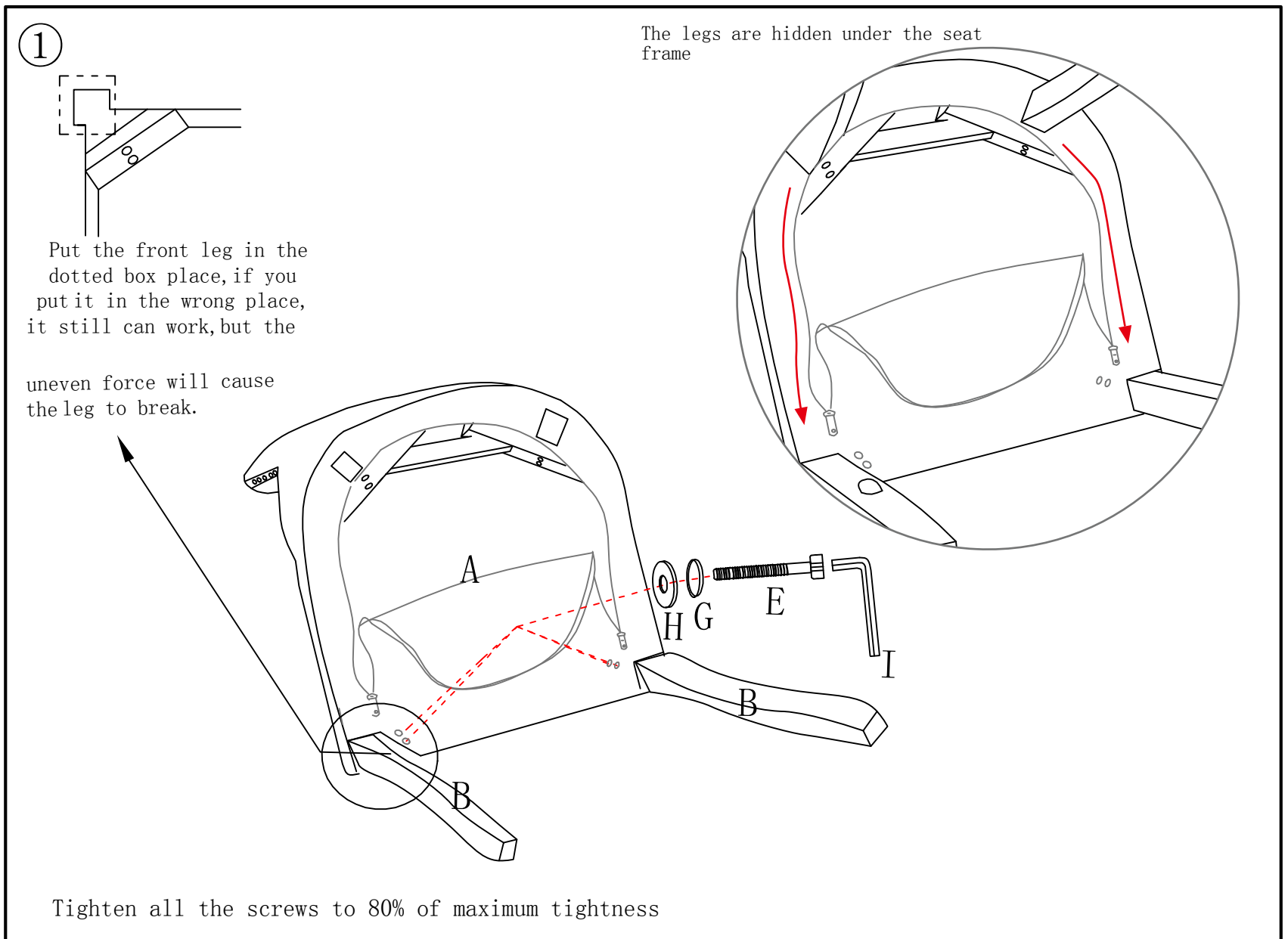
DO NOT STAND ON THE PRODUCT, DO NOT USE THIS PRODUCT AS A STEP LADDER.
DO NOT USE THIS PRODUCT UNLESS ALL BOLTS, SCREWS AND KNOBS ARE FIRMLY SECURED.
PLEASE DO NOT USE KNIFE TO OPEN ANY PARTS OF THE BOX OR PRODUCT.

2

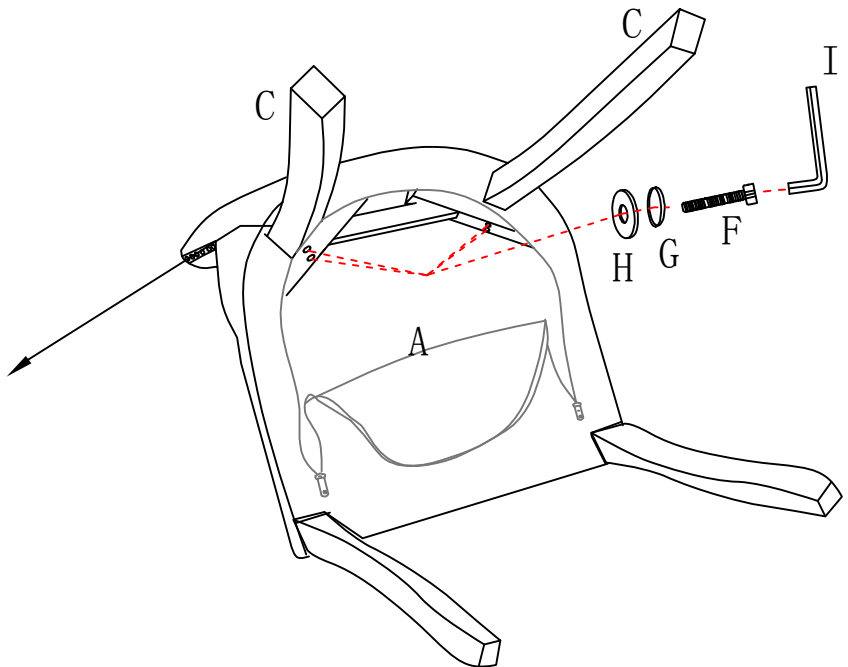
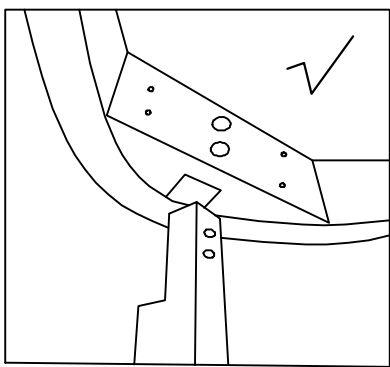
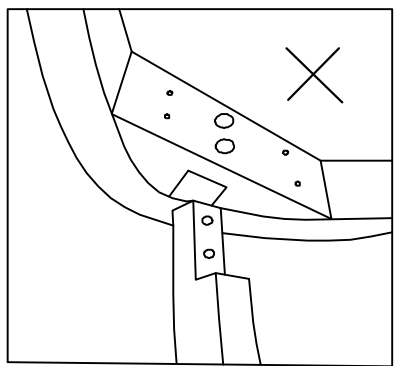

Tighten all the screws to 80% of maximum tightness

3

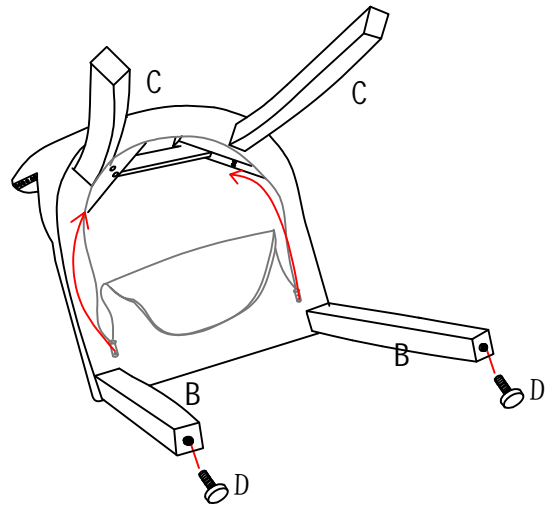

1. screw D into B
2. Carefully sit on the chair and make adjustments to ensure the legs are flat even on the floor.
3. Tighten all the screws to 100% of maximum tightness
4. Close the zipper of bottom Non-Woven fabric.

4

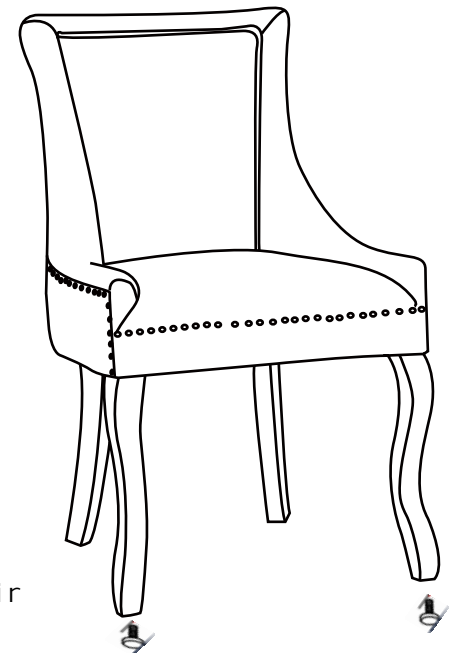

Adjust the adjuster bolt to keep the chair level again