

Assembly Instructions

# Dining Table

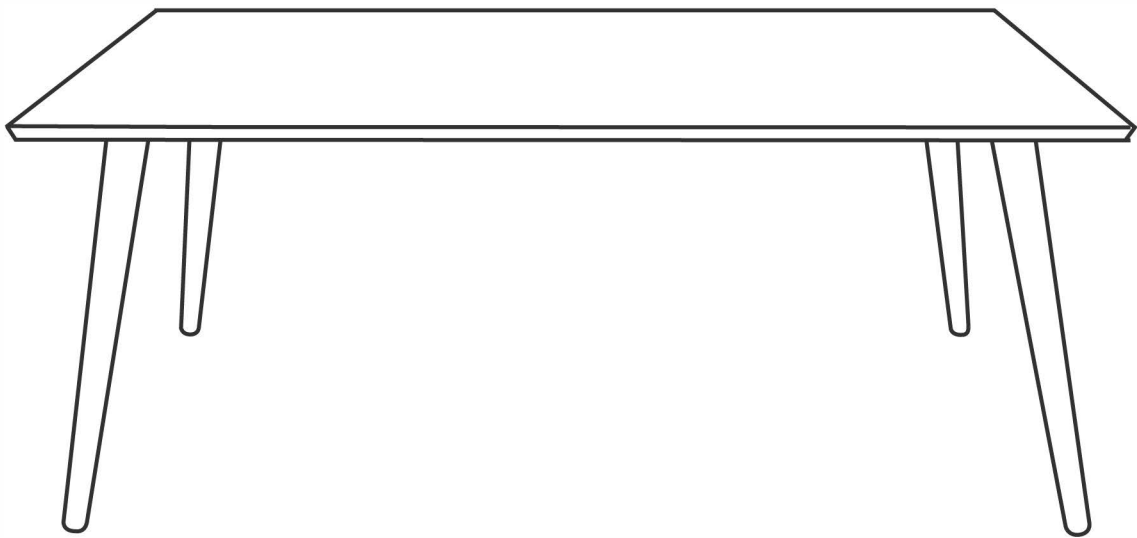

## Assembly Instructions

# Dining Table

### ASSEMBLY REQUIREMENT

**2 PERSON ASSEMBLY | 20 MINUTES ASSEMBLY TIME (APPROXIMATE)**

### ASSEMBLY PREPARATION

1. Remove all packaging materials, staples and packing straps from the carton.
2. Refer to Parts Checklist and ensure they are complete before you start assembling.
3. Place all components on a clean, flat and soft surface (e.g. carpet or rug) to prevent parts from getting scratched.

### TIPS FOR ASSEMBLY

1. Allow ample room for assembly and in close proximity to where product will be placed.
2. Assemble the product on a surface that does not scratch or damage the exterior and finish of the furniture.
3. During assembly, do not over-tighten any fittings as this may cause damage.
4. **DO NOT USE POWER TOOLS TO ASSEMBLE THIS PRODUCT.**
5. Do not sit or stand on the partially assembled product, only use the product for which it is intended.

### CARE AND USE

- Recommended for indoor and residential use only.
- Please exercise caution when placing food or drinks on the surface. Use of a coaster or placemat is highly recommended to avoid damage to surface.
- Wipe with a soft, dry cloth. Do not use harsh abrasives or household cleaners as they may damage the finish.
- Check all the fittings periodically and re-tighten as necessary. Do not use the product if any of the parts is damaged or broken.
- Never allow any kind of liquid to remain on your furniture. Absorption can cause surface to warp or delaminate.
- Do not place hot items (e.g. hot drinks) directly onto the surface.
- Do not drag and/or pull the furniture.

**SAFETY PRECAUTIONS: 1. KEEP ALL HARDWARE PARTS OUT OF REACH OF CHILDREN. 2. DISPOSE PLASTIC PACKAGING MATERIAL IMMEDIATELY TO AVOID ANY RISK OF SUFFOCATION TO CHILDREN AND ANIMALS.**

## PARTS CHECKLIST

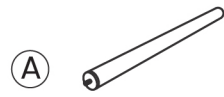

X4 Legs

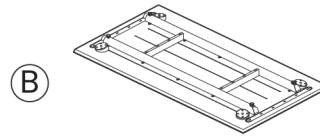
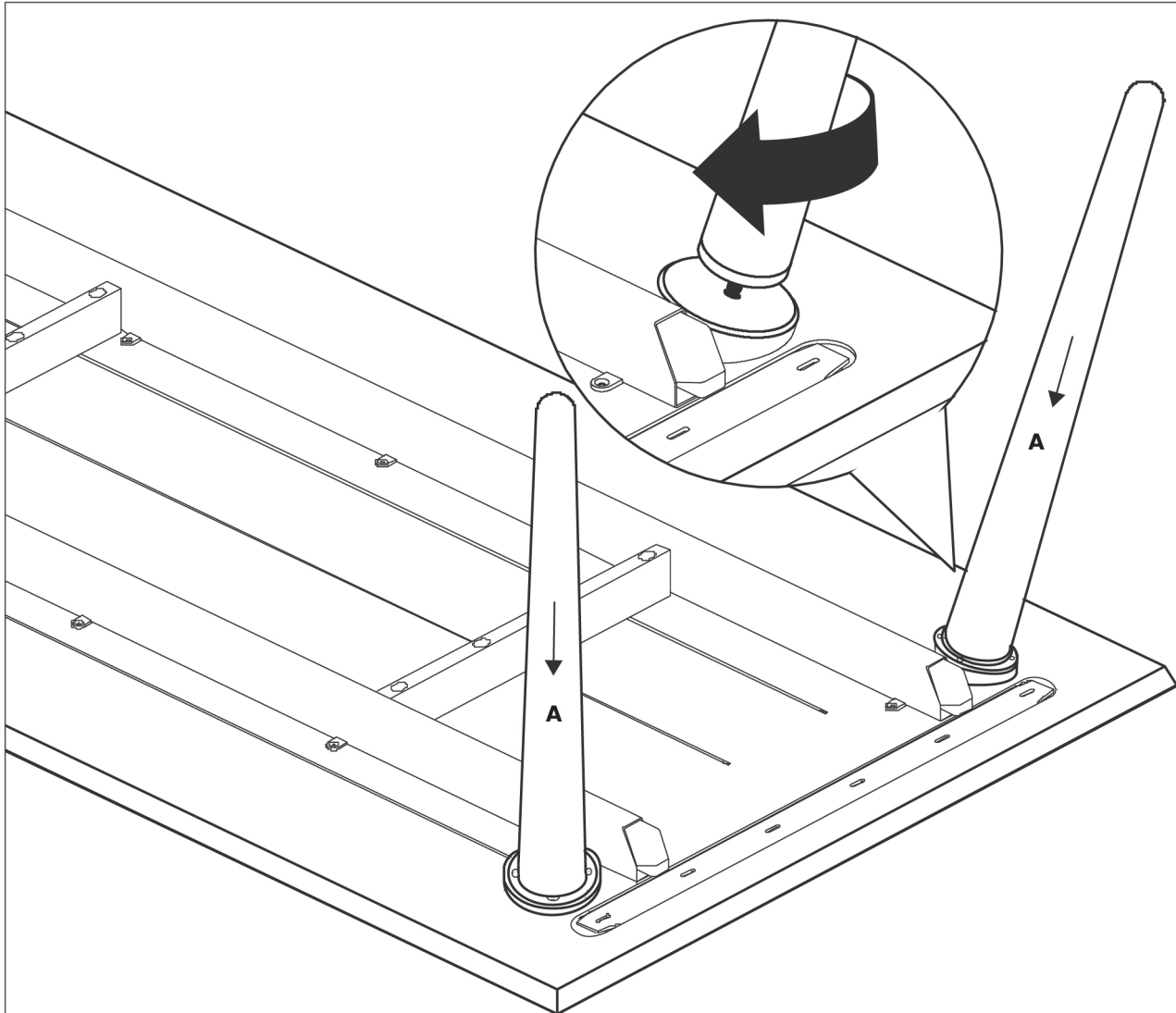

Table Top



### STEP 1.

Place table top upside-down on clean, soft surface. Attach legs **A** by screwing into table top as shown above, and tighten firmly. With another person, gently place table top upright. **Do not use legs as a lever to place table upright.**

### STEP 2.

Make a pot of your favorite herbal tea, put on some light jazz and invite your friends over for some engaging conversation. Enjoy!