

NOTICE

- * Please make sure that you have all parts indicated and they are in good condition before you begin assembly of this item. Refer to part list and hardware list below for guidance.
- * This item should be assembled on a soft surface to prevent scratching the finished goods during assembly.
- * This item may require periodic tightening.

PREPARATION

- * Before beginning assembly of product, make sure all parts are present. Compare parts with part contents list and hardware contents list.
- * If any part is missing or damaged, do not attempt to assemble the product.
- * Estimated Assembly Time: 40 minutes.
- * Tools Required for Assembly : Allen key (included) & Phillips head screwdriver (not included)

CARE AND MAINTENANCE

INDOOR METAL/ALUMINUM FURNITURE: Wipe spills immediately. Maintain with regular dusting and clean with mild soap and water, dry thoroughly and do not use a brass cleaner. Adhesive felt pads should always be used/applied in order to prevent damage to the furniture or surfaces on which the furniture is placed.

WOOD CARE: Adhesive felt pads should always be applied to areas of furniture which make direct contact with flooring, said application will prevent damage to the furniture and or surfaces on which the furniture lies. Objects placed on articles of furniture should rest on non abrasive material as to prevent damage to the wood finish. Wipe up spills immediately and avoid common hazards such as hot dishes, harsh solvents and abrasives. Cleaning should be done with a soft lint free cotton cloth dampened with water or furniture polish.

Product Dimensions: 38"W x 13"D x 70.25"H

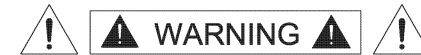
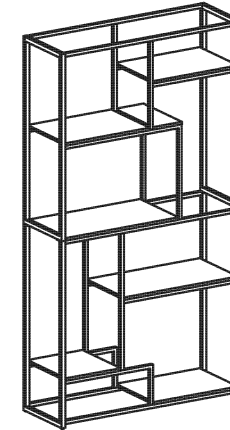

Weight Capacity : 30 lbs of each shelf
Warning : Do not stand on the product
Warning : Do not over torque bolts

Part List and Hardware List

PIECE	DESCRIPTION	PICTURE	QUANTITY
A	Shelf-1		2x
B	Shelf-2		3x
C	Shelf-3		1x
D	Shelf-4		1x
E	Left Side Frame (Upper)		1x
F	Right Side Frame (Upper)		1x
G	Left Side Frame (Lower)		1x
H	Right Side Frame (Lower)		1x

PIECE	DESCRIPTION	PICTURE	QUANTITY
I	Connecting bar-1		2x
J	Connecting bar-2		2x
K	Connecting bar-3		2x
L	Connecting bar-4		2x
M	Connecting bar-5		2x
N	Connecting bar-6		2x
O	Connecting bar-7		2x
P	Connecting bar-8		2x
Q	Connecting bar-9		2x

PIECE	DESCRIPTION	PICTURE	QUANTITY
HW1	Hex Socket Bolt	1/4"-20*0.5"	4x
HW2	Hex Socket Bolt	1/4"-20*1.S"	36x
HW3	Wood Screw	<1>8*29mm	28x
HW4	Allen Key	M4	1x
HWS	Anti-Tip Hardware		2x

PREPARATION

- * Before beginning assembly of product, make sure all parts are present. Compare parts with part contents list and hardware contents list.
- * If any part is missing or damaged, do not attempt to assemble the product.
- * Estimated Assembly Time: 40 minutes.
- * Tools Required for Assembly : Allen key (included) & Phillips head screwdriver (not included)

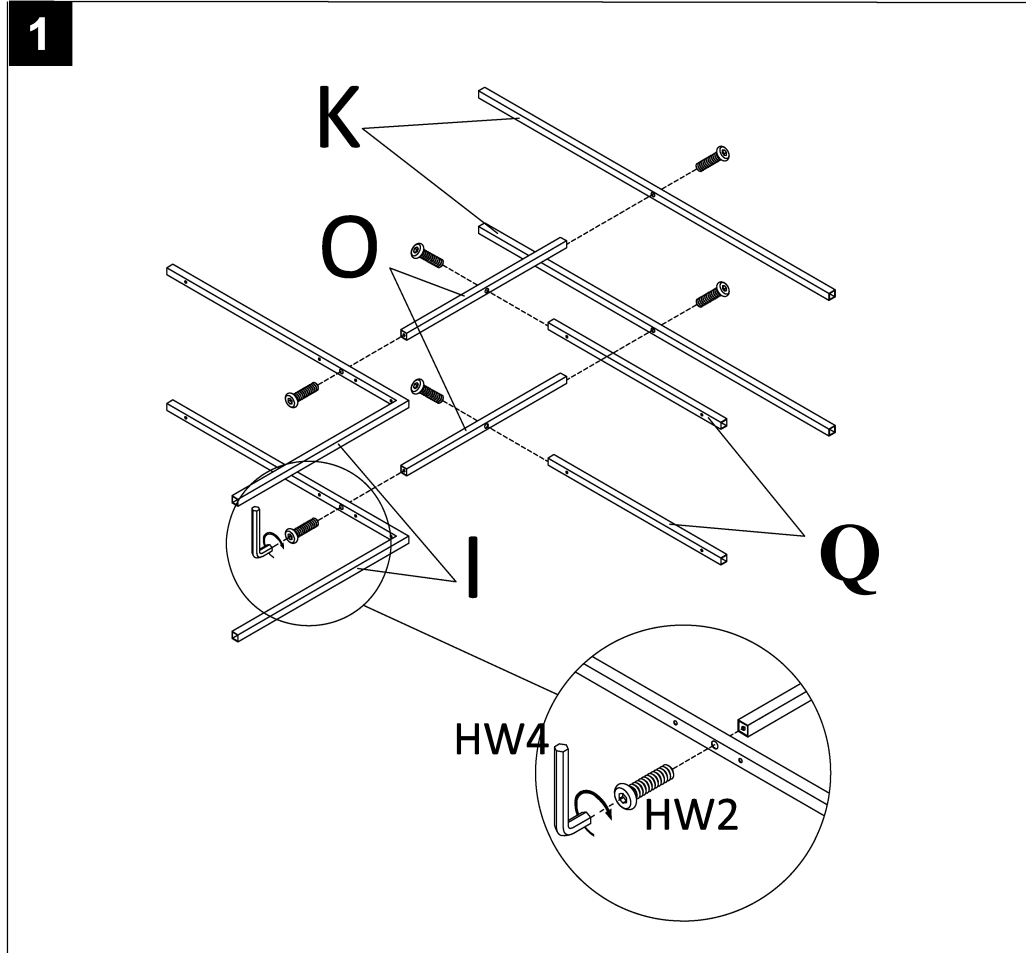

Step 1 : (UPPER HALF)

Use 4*Hex Socket Bolts (HW2) to pass through 2*connecting bar-3 (K) & 2*connecting bar-1 (I) and lock aforesaid 4*connecting bars (2*K & 2*I) from ends of the 2*connecting bar-7 (O) by Allen Key (HW4) respectively.
Then use 2*Hex Socket Bolts (HW2) to pass through 2*connecting bar-7 (O) and lock with 2*connecting bar-9 (Q) by Allen Key (HW4) respectively, as picture.

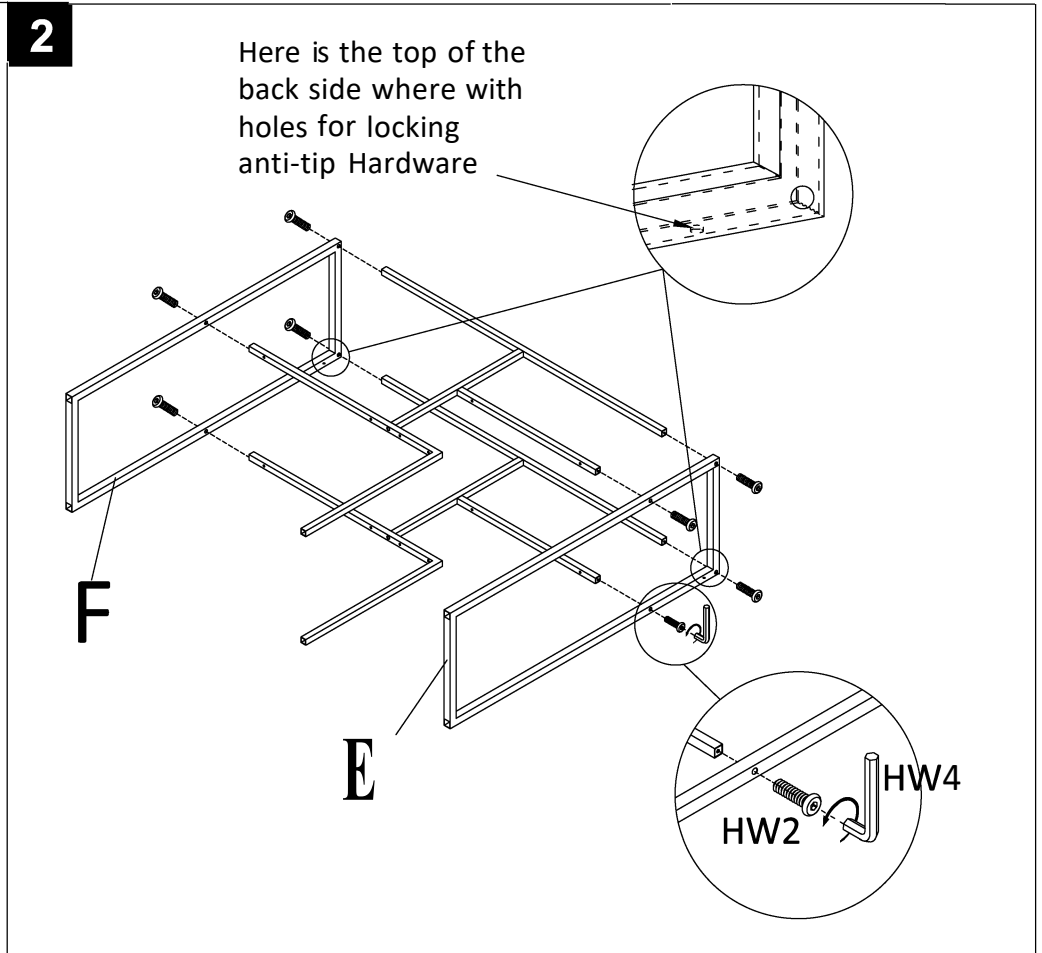

Step 2 : (UPPER HALF)

Step 2 : (UPPER HALF)
Place the Left Side Frame (Upper) (E) & Right Side Frame (Upper) (F) on both ends of assembled connecting bars (step1) respectively, Using the Allen Key (HW4) to lock with 8*Hex Socket Bolts (HW2).

PREPARATION

- * Before beginning assembly of product, make sure all parts are present. Compare parts with part contents list and hardware contents list.
- * If any part is missing or damaged, do not attempt to assemble the product.
- * Estimated Assembly Time: 40 minutes.
- * Tools Required for Assembly : Allen key (included) & Phillips head screwdriver (not included)

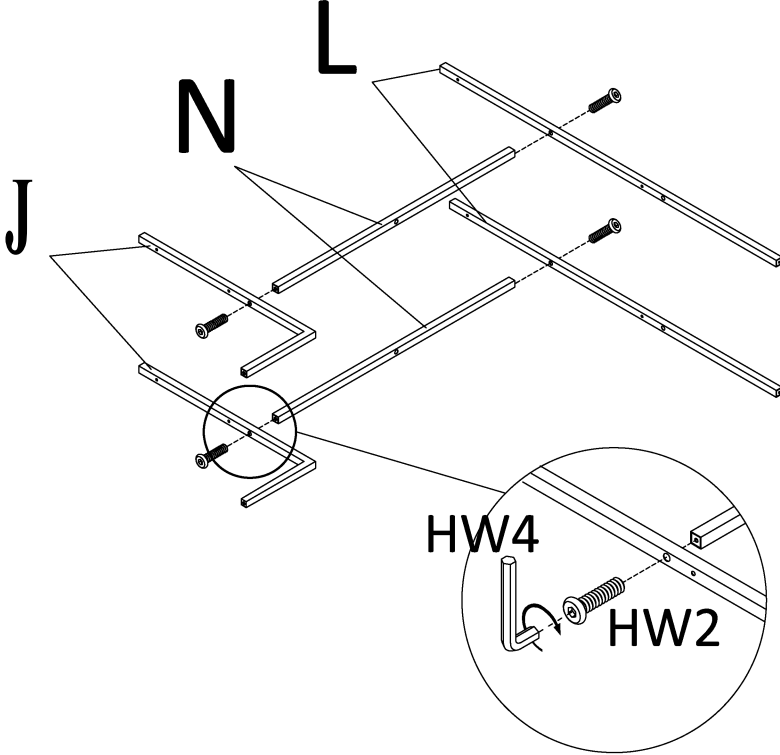
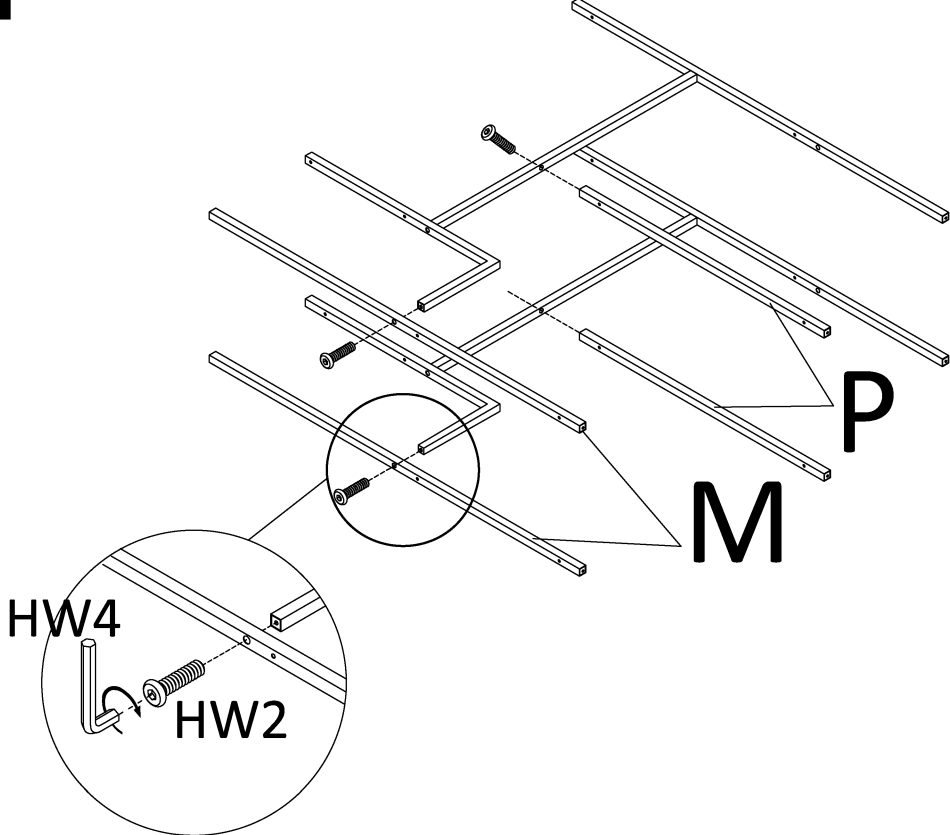
<p>3</p> 	<p>4</p> 
<p>Step 3 : (LOWER HALF) Attach 2*connecting bar-4 (L) & 2*connecting bar-2 (J) to the ends of 2*connecting bar-6 (N), As shown in the above diagram to align the holes, and use 4*Hex Socket Bolts (HW2) to lock by using Allen Key (HW4).</p>	<p>Step 4 : (LOWER HALF) Then attach 2*connecting bar-8 (P) and 2*connecting bar-5 (M) to the corresponding holes of the parts assembled in the fore-step, as shown in the above diagram to align the holes, and use 4*Hex Socket Bolts (HW2) to lock by using Allen Key (HW4).</p>

PREPARATION

* Before beginning assembly of product, make sure all parts are present. Compare parts with part contents list and hardware contents list.

* If any part is missing or damaged, do not attempt to assemble the product.

* Estimated Assembly Time: 40 minutes.

* Tools Required for Assembly : Allen key (included) & Phillips head screwdriver (not included)

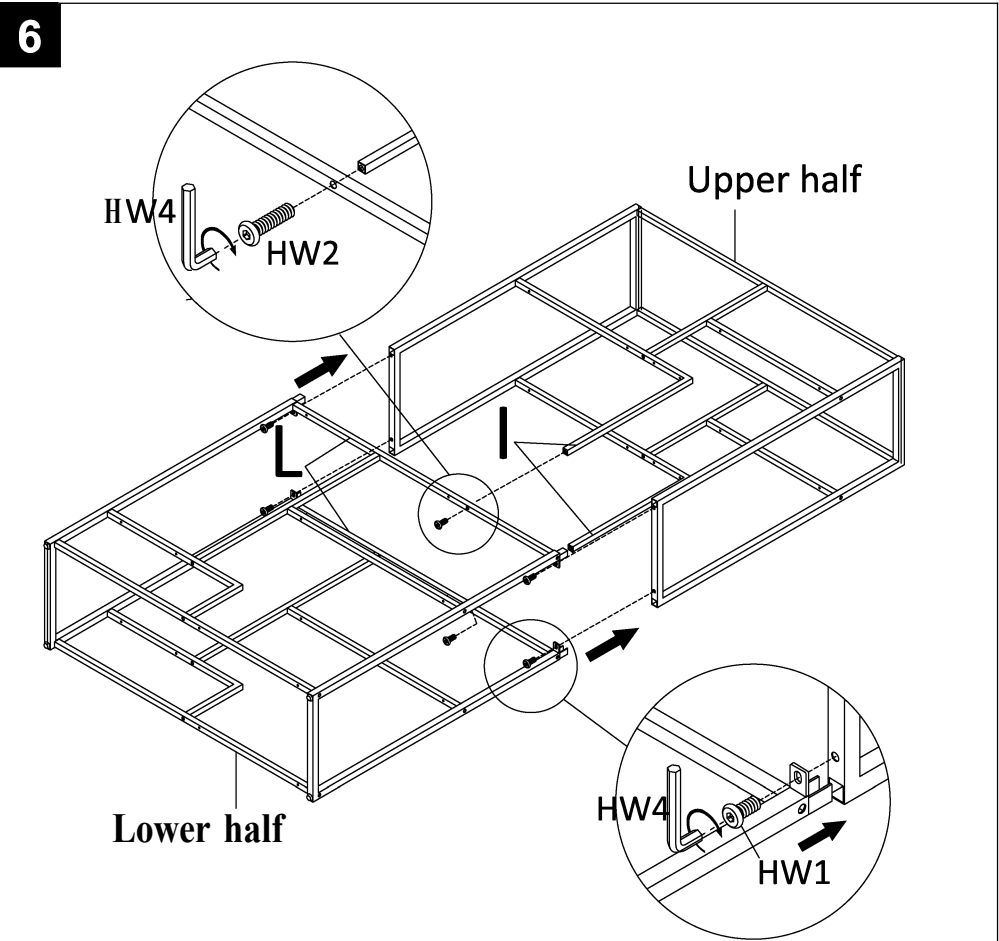
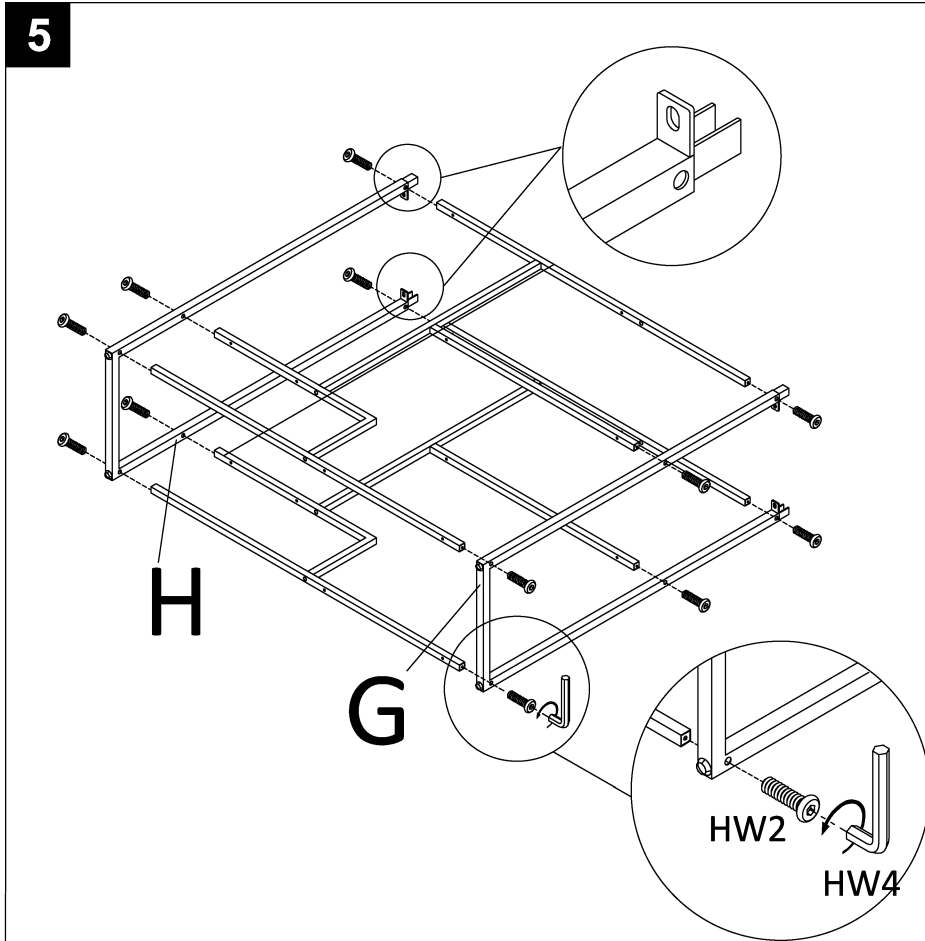

Step 5 : (LOWER HALF)

Place the Left Side Frame (Lower) (G) & Right Side Frame (Lower) (H) on both ends of assembled connecting bars (step3) respectively, Using the Allen Key (HW4) to lock with 12*Hex Socket Bolts (HW2).

Step 6

Align the assembled upper half with the lower half of the iron frame. Use 4*Hex Socket Bolts (HW1) to lock the lower half with upper half of iron frame by Allen Key (HW4). Then use 2*Hex Socket Bolts (HW2) to pass through 2*connecting bar-4 (L) and lock with 2*connecting bar-1 (I) by Allen Key (HW4) respectively.

PREPARATION

* Before beginning assembly of product, make sure all parts are present. Compare parts with part contents list and hardware contents list.

* If any part is missing or damaged, do not attempt to assemble the product.

* Estimated Assembly Time: 40 minutes.

* Tools Required for Assembly : Allen key (included) & Phillips head screwdriver (not included)

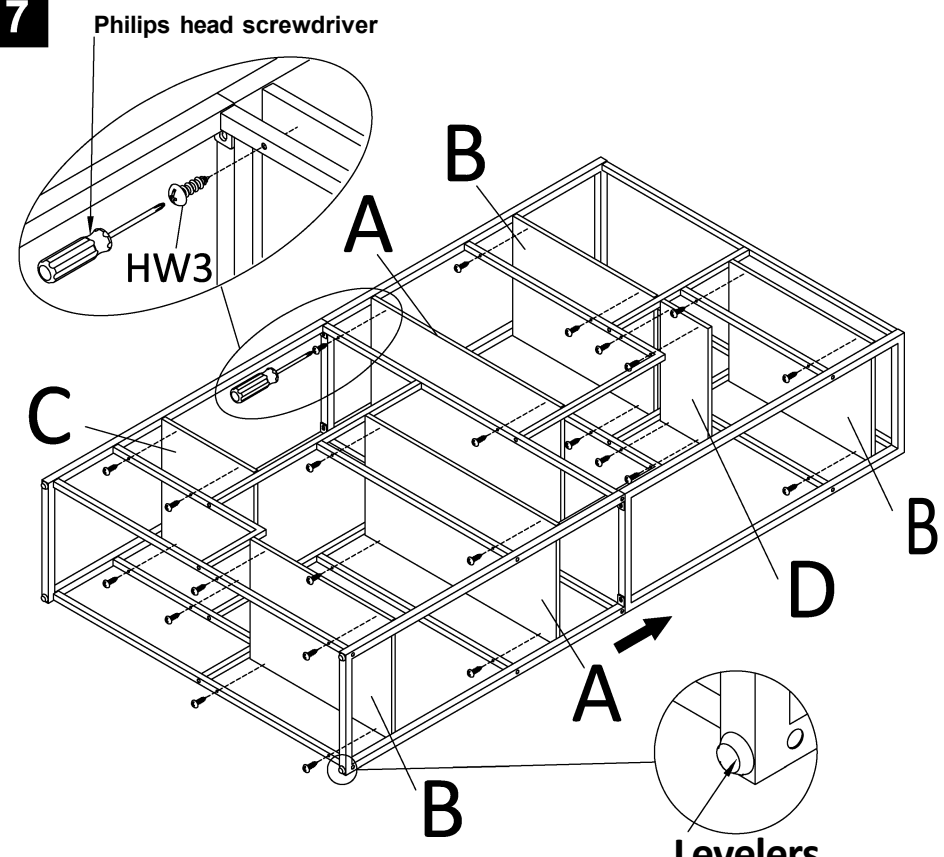
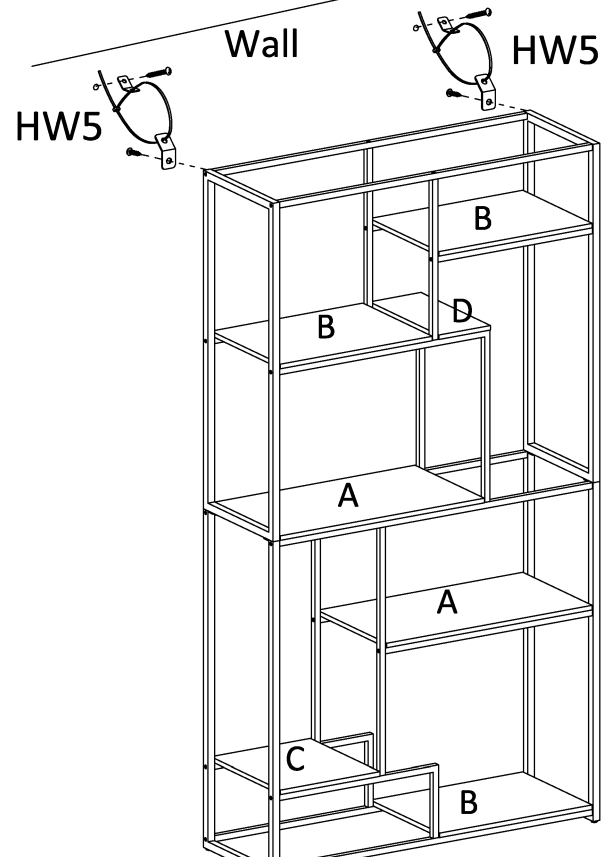
<p>7</p> <p>Philips head screwdriver</p>  <p>HW3</p> <p>A B C D B A B</p> <p>Levelers</p>	<p>8</p>  <p>Wall</p> <p>HW5</p> <p>HW5</p> <p>A B C D B A C B</p>
<p>Step 7</p> <p>Attach underneath of Shelves to the assembled iron frame in corresponding positions, as above drawing indicated, Use Philips head screwdriver (tool is not included) to lock 28*Wood screws (HW3) to pass through the iron tubes to lock on 7*shelves, as picture.</p> <p>P.S. Each Shelf is locked through iron tubes with 4*wood screws (HW3).</p>	<p>Step 8</p> <p>Straighten up the assembled product, Following the Installation Instructions of anti-tip hardware (HWS) to fix the product with wall by 2 straps, Assembly is completed.</p>