

ASSEMBLY INSTRUCTIONS







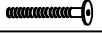

Read this instruction carefully. See hardware and furniture part list for guidance. Be sure all parts are complete, before you assemble. Place all wooden furniture parts on a clean and flat soft surface to prevent from being scratched. Follow the figure to start assembling.

CAUTIONS : 1. Do not FULLY - TIGHTEN the nut or nut bolt until all nut or bolt is ready assembled.
2. Do not OVER - TIGHTEN the nut or bolt to avoid causing damages to the thread.
3. Keep all hardware parts out of reach of children.

NOTE : THE LIST AND QUANTITY SHOWN ARE FOR 1 UNIT ASSEMBLY.

Tool needed : Screwdriver & Rubber Mallet (not provider).

PART LIST		
ITEM	DESCRIPTION	QTY
A	CUSHION BACK	1 PC
B	CUSHION SEAT	1 PC
C	LEG SUPPORT FRONT	1 PC
D	LEG SUPPORT BACK	1 PC
E	LEG LEFT	1 PC
F	LEG RIGHT	1 PC

HARDWARE LIST		
ITEM	DESCRIPTION	QTY
1	JCBC Bolt M6 x 50mm 	4pcs
2	JCBB Bolt M8 x 45mm 	6pcs
3	M8 FLAT WASHER 	6pcs
4	M6 SPRING WASHER 	4pcs
5	M8 SPRING WASHER 	6pcs
6	WOOD SCREW M4 x 38mm 	10PCS
7	M4 ALLEN KEY (BALL SHAPE) 	1PC
8	M5 ALLEN KEY (BALL SHAPE) 	1PC
9	WOOD DOWEL M8 x 30mm 	8PCS

STEP 1

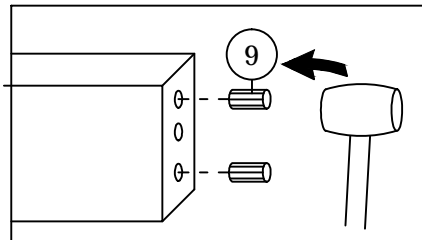
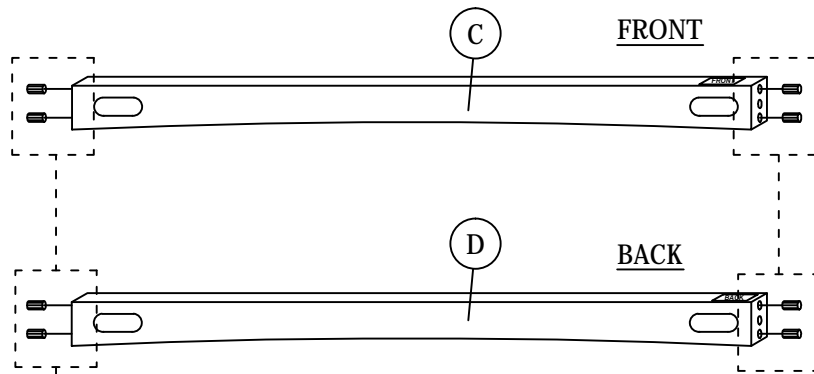

STEP 2

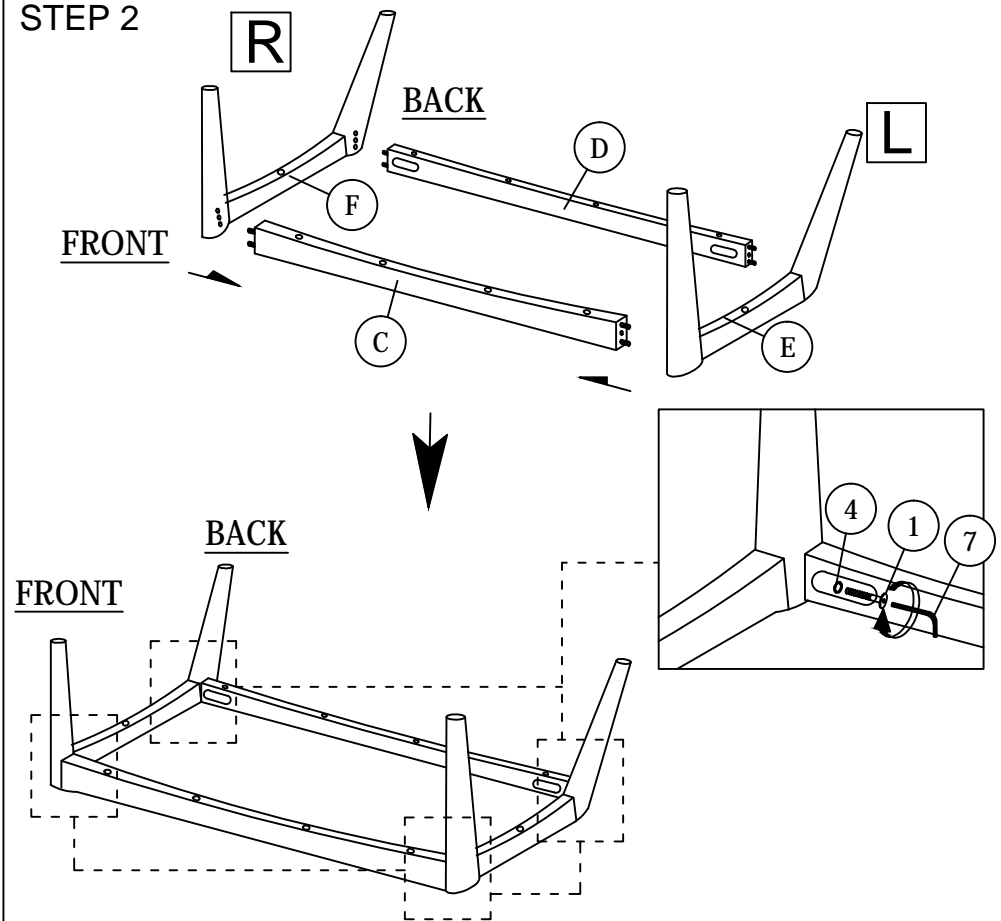

ASSEMBLY INSTRUCTIONS

STEP 3

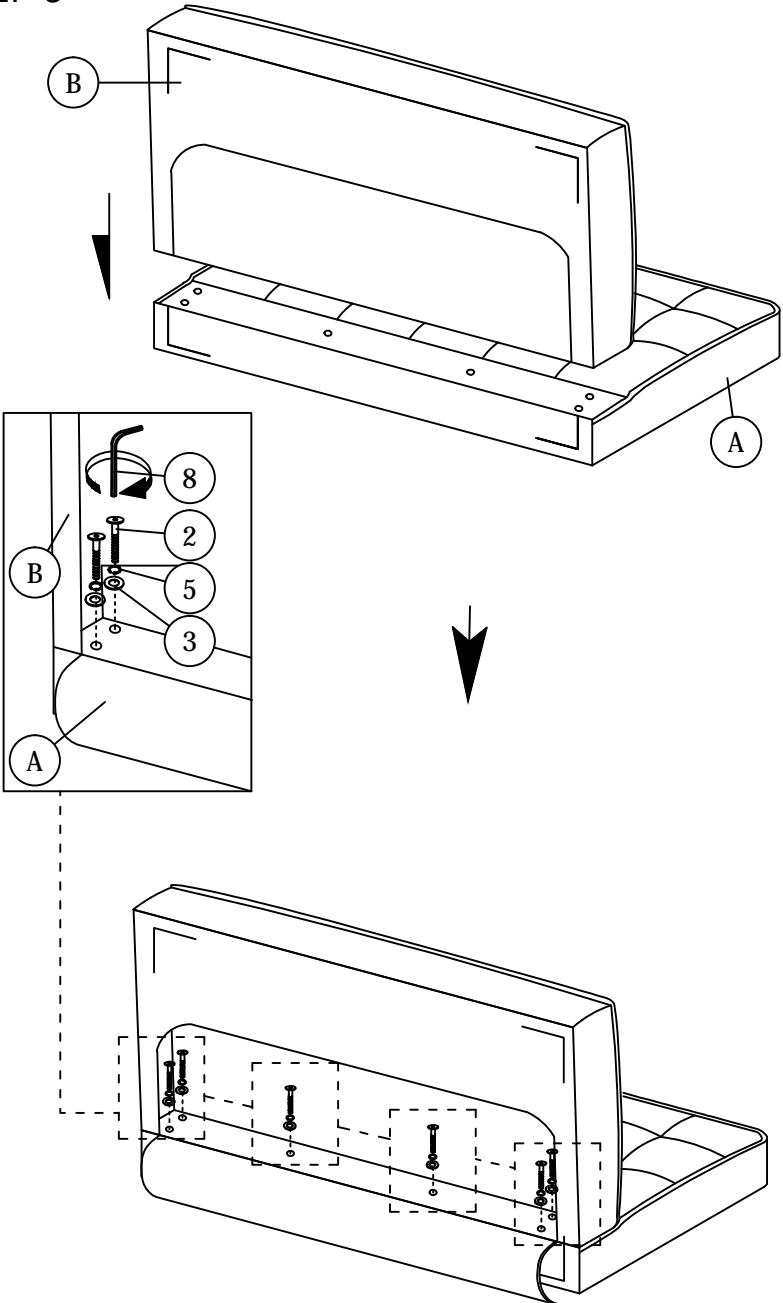

STEP 4

4.1 Follow marking line assemble leg.

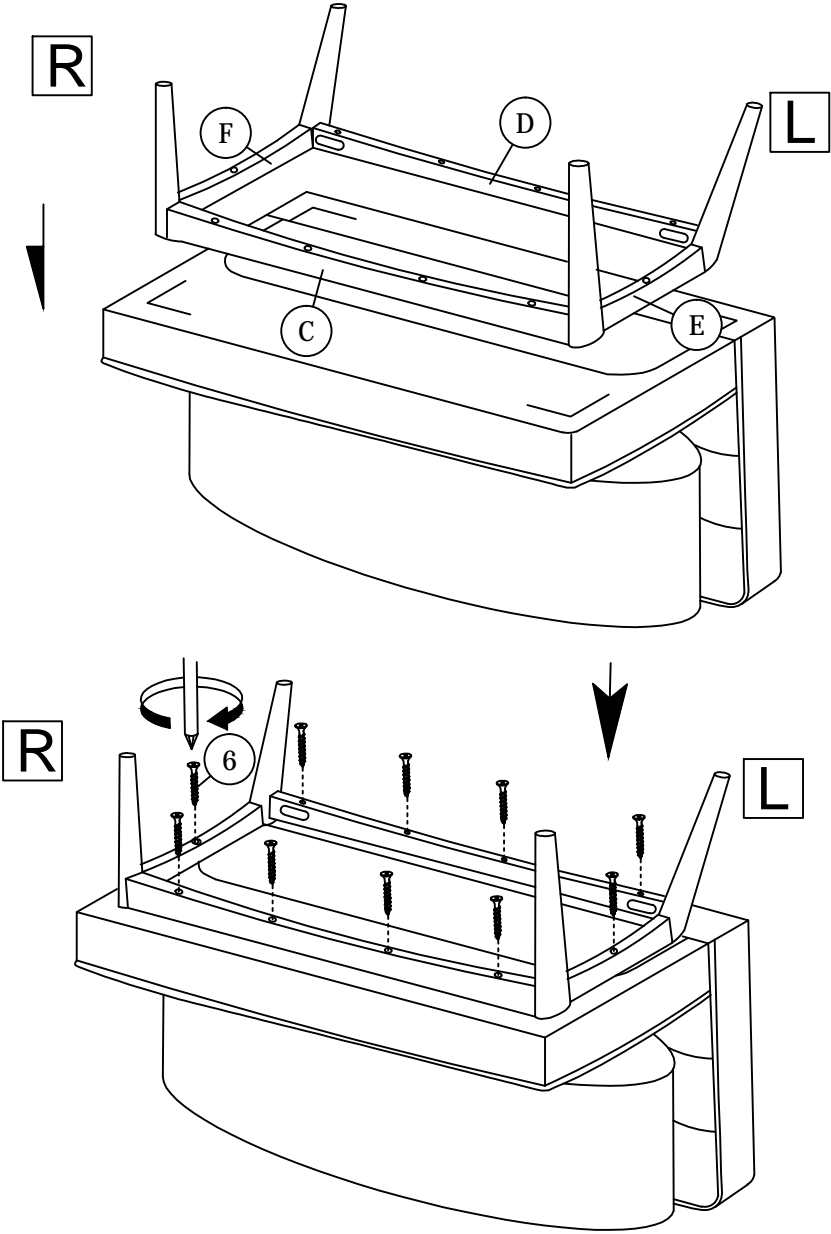

STEP 5

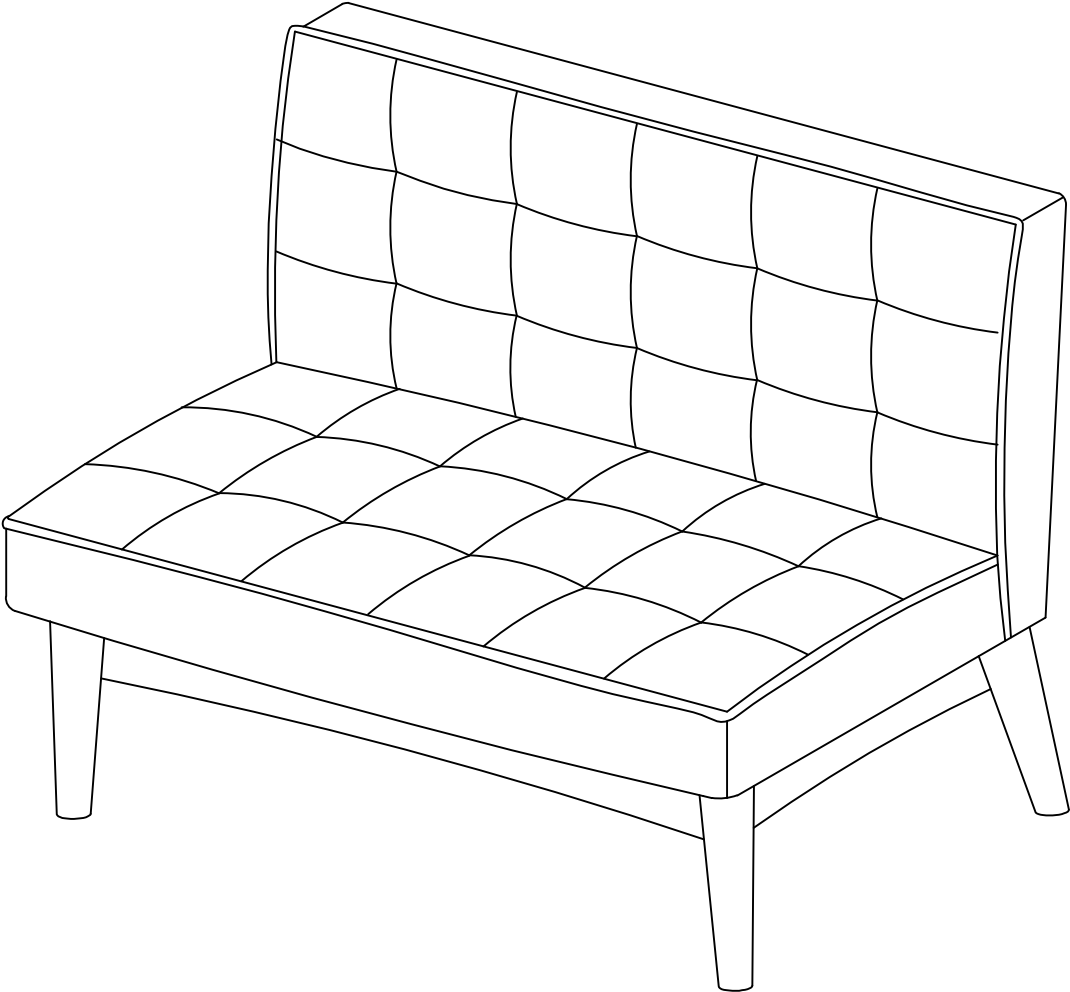









ASSEMBLY INSTRUCTIONS

Read this instruction carefully. See hardware and furniture part list for guidance. Be sure all parts are complete, before you assemble. Place all wooden furniture parts on a clean and flat soft surface to prevent from being scratched. Follow the figure to start assembling.

CAUTIONS : 1. Do not FULLY - TIGHTEN the nut or nut bolt until all nut or bolt is ready assembled.
 2. Do not OVER - TIGHTEN the nut or bolt to avoid causing damages to the thread.
 3. Keep all hardware parts out of reach of children.

NOTE : THE LIST AND QUANTITY SHOWN ARE FOR 1 UNIT ASSEMBLY.
 Tool needed : Screwdriver & Rubber Mallet (not provider).

PART LIST		
ITEM	DESCRIPTION	QTY
A	CUSHION BACK	1 PC
B	CUSHION SEAT	1 PC
C	LEG SUPPORT FRONT	1 PC
D	LEG SUPPORT BACK	1 PC
E	LEG LEFT	1 PC
F	LEG RIGHT	1 PC
G	ARM	1 PC

HARDWARE LIST		
ITEM	DESCRIPTION	QTY
1	JCBC Bolt M6 x 50mm 	4pcs
2	JCBB Bolt M8 x 45mm 	8pcs
3	M8 FLAT WASHER 	8pcs
4	M6 SPRING WASHER 	4pcs
5	M8 SPRING WASHER 	8pcs
6	WOOD SCREW M4 x 38mm 	10PCS
7	M4 ALLEN KEY (BALL SHAPE) 	1PC
8	M5 ALLEN KEY (BALL SHAPE) 	1PC
9	WOOD DOWEL M8 x 30mm 	8PCS

STEP 1

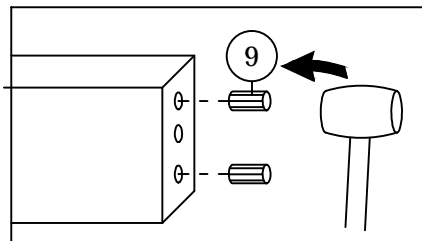
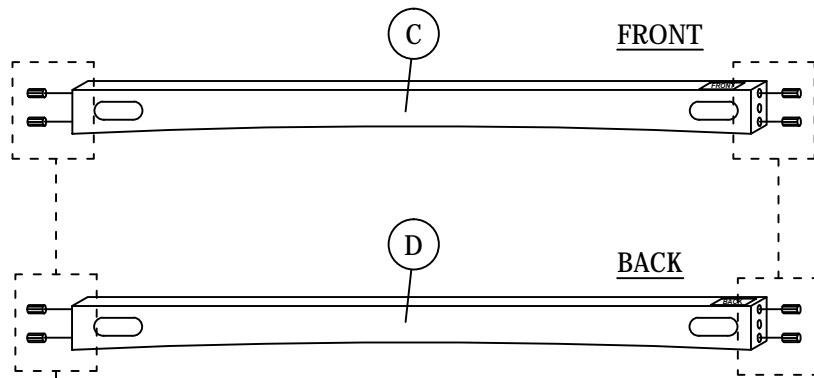

STEP 2

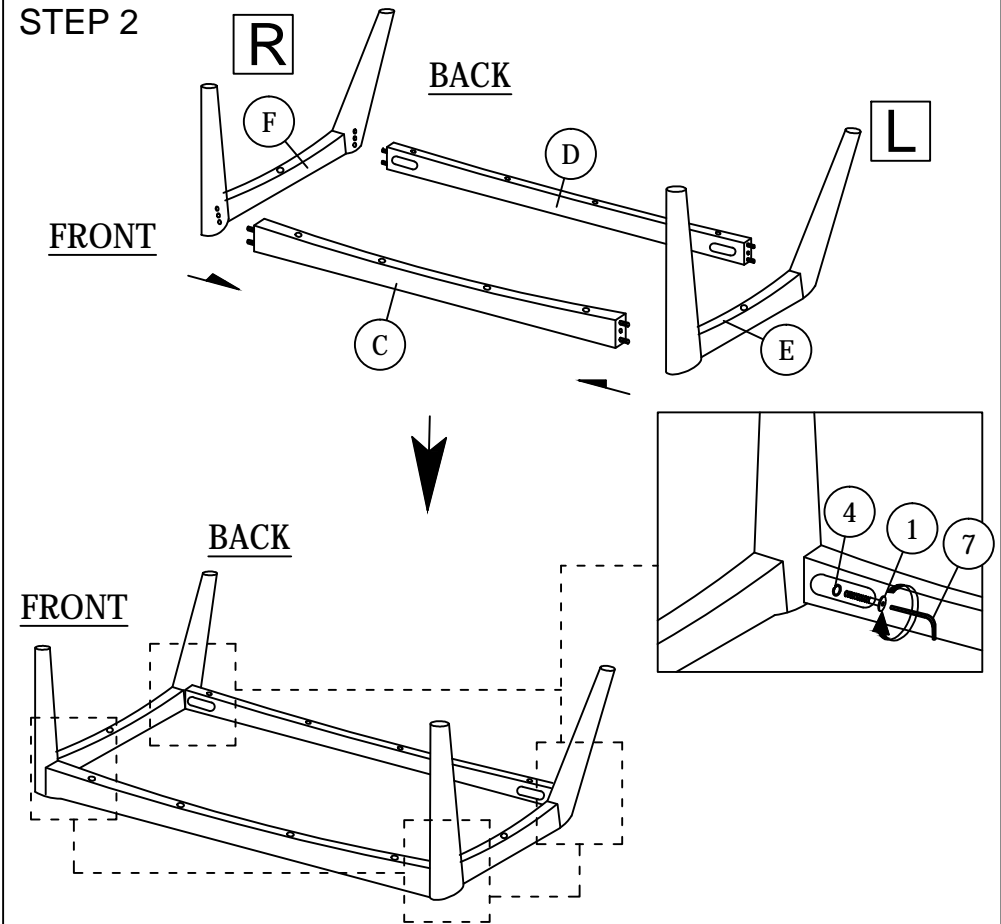

STEP 3

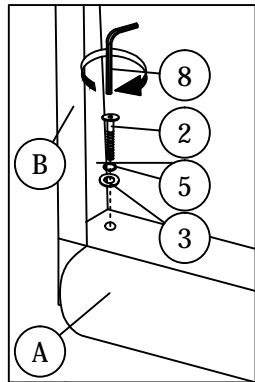
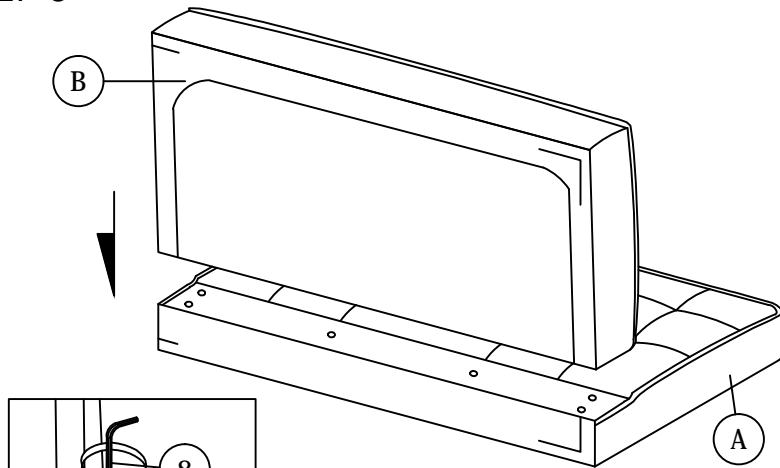

Don't screw tied

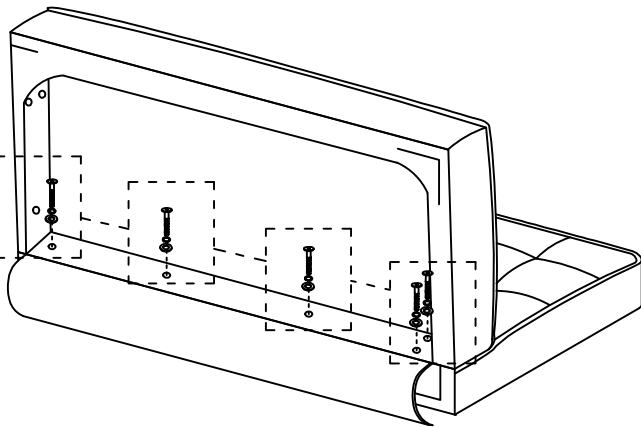

STEP 4

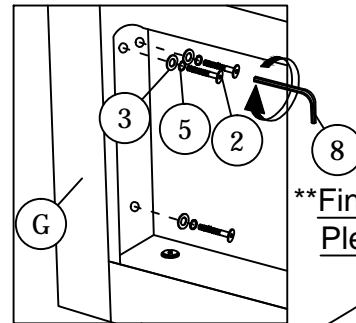
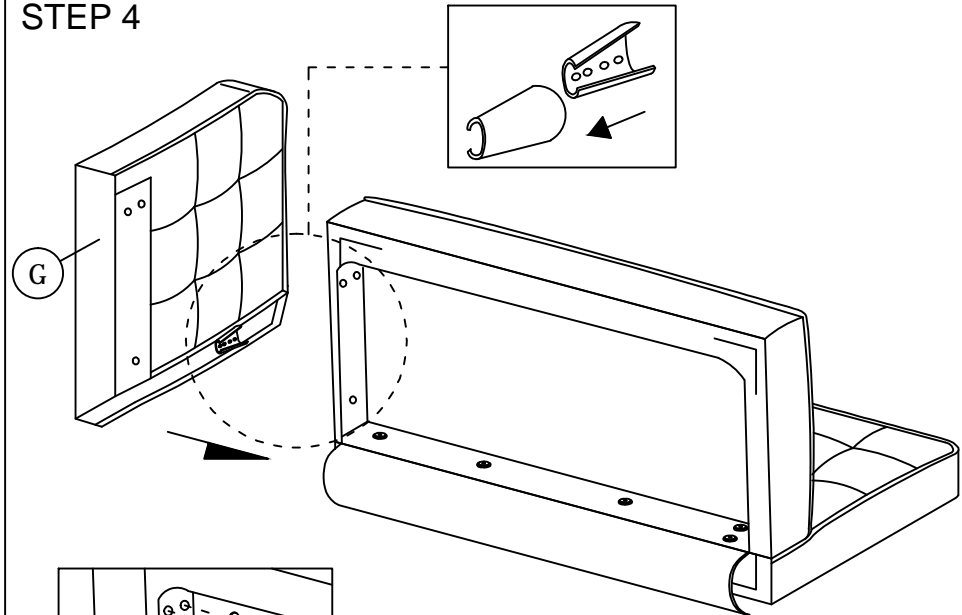

** Finish step 4,
Please screw tied the step 3 bolt.

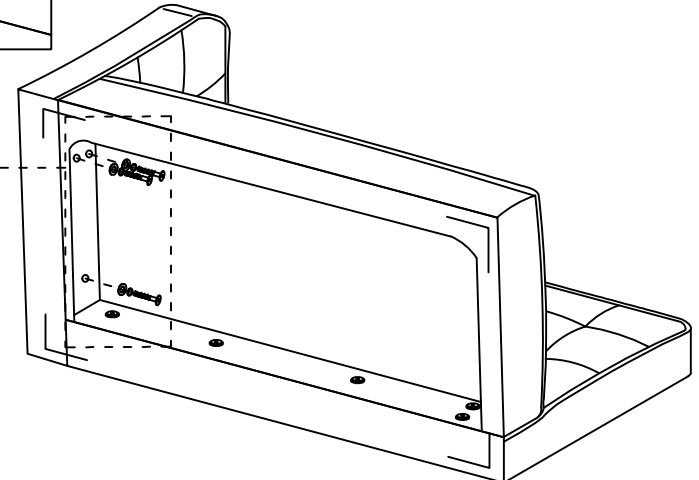

ASSEMBLY INSTRUCTIONS

STEP 5 5.1 Follow marking line assemble leg.

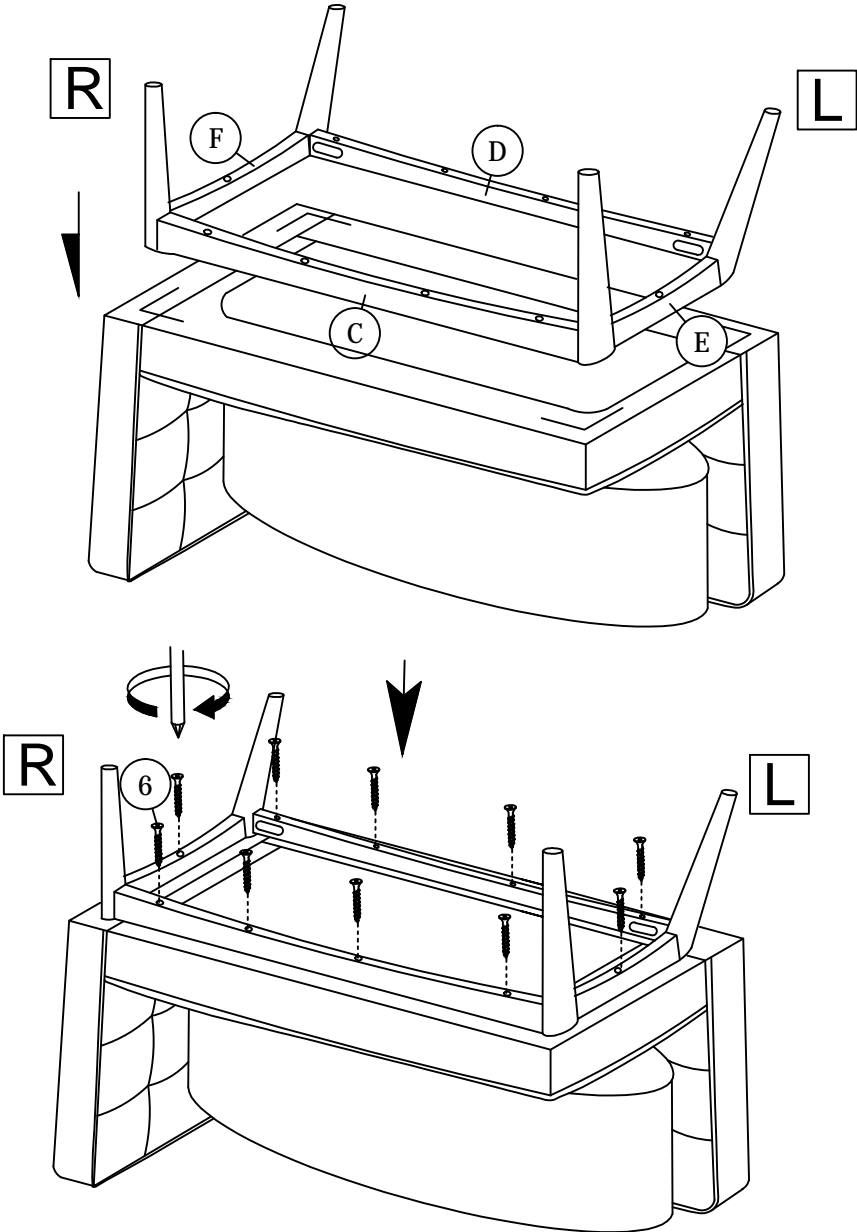

STEP 6

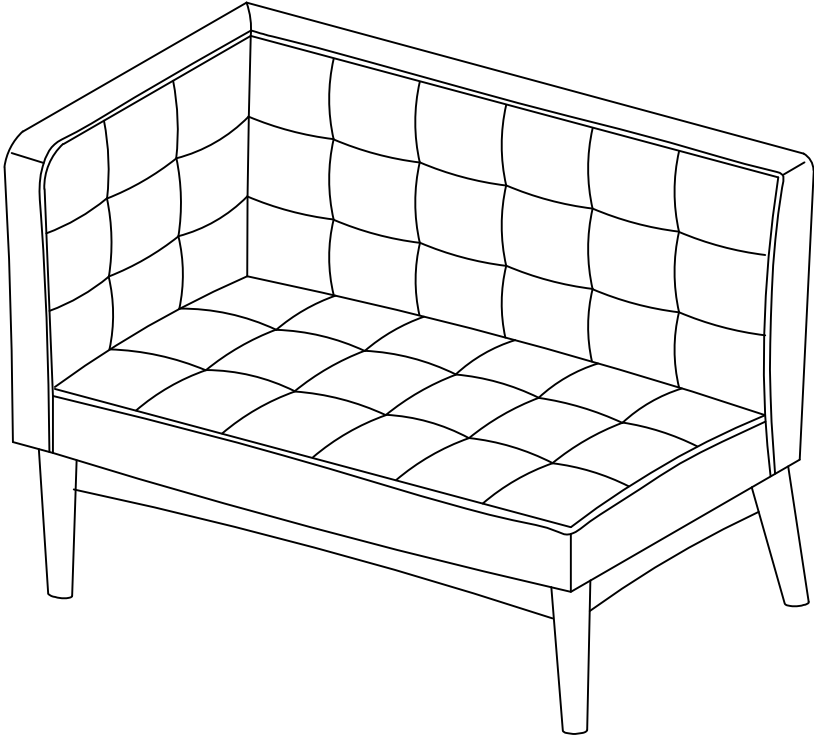

ASSEMBLY INSTRUCTIONS





Read this instruction carefully. See hardware and furniture part list for guidance. Be sure all parts are complete, before you assemble. Place all wooden furniture parts on a clean and flat soft surface to prevent from being scratched. Follow the figure to start assembling.

CAUTIONS : 1. Do not FULLY - TIGHTEN the nut or nut bolt until all nut or bolt is ready assembled.
2. Do not OVER - TIGHTEN the nut or bolt to avoid causing damages to the thread.
3. Keep all hardware parts out of reach of children.

NOTE : THE LIST AND QUANTITY SHOWN ARE FOR 1 UNIT ASSEMBLY.

Tool needed : Screwdriver & Rubber Mallet (not provider).

PART LIST		
ITEM	DESCRIPTION	QTY
A	CUSHION SEAT	1 PC
B	LEG SUPPORT	2 PCS
C	LEG	2 PCS

HARDWARE LIST		
ITEM	DESCRIPTION	QTY
1	JCBC Bolt M6 x 50mm 	4pcs
2	M6 SPRING WASHER 	4pcs
3	WOOD SCREW M4 x 38mm 	8PCS
4	M4 ALLEN KEY (BALL SHAPE) 	1PC
5	WOOD DOWEL M8 x 30mm 	8PCS

STEP 1

1.1 Open the zip at the bottom of cushion seat and take out all part hardware.

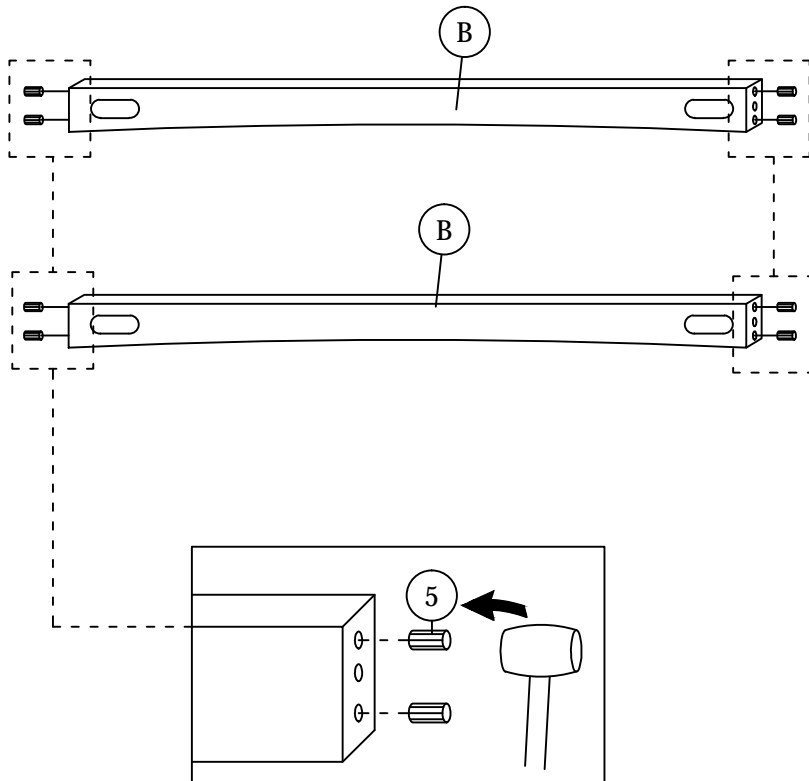

STEP 2

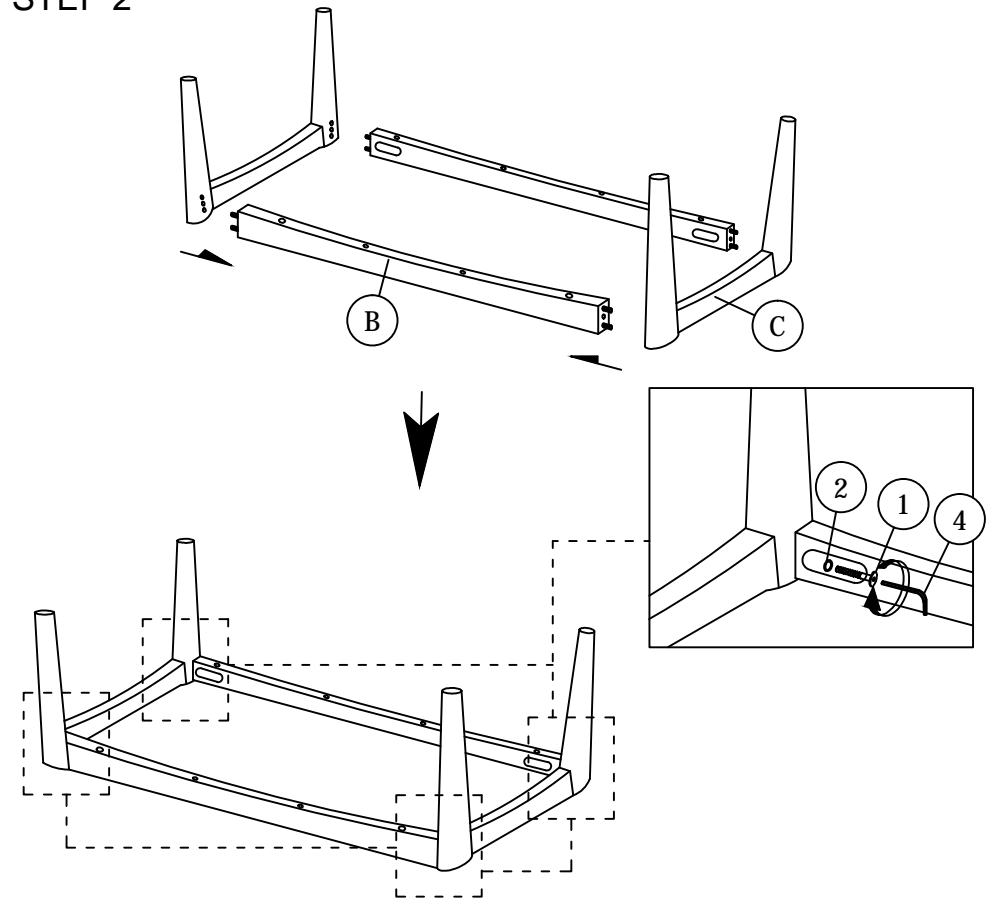

ASSEMBLY INSTRUCTIONS

STEP 3

3.1 Follow marking line assemble leg.

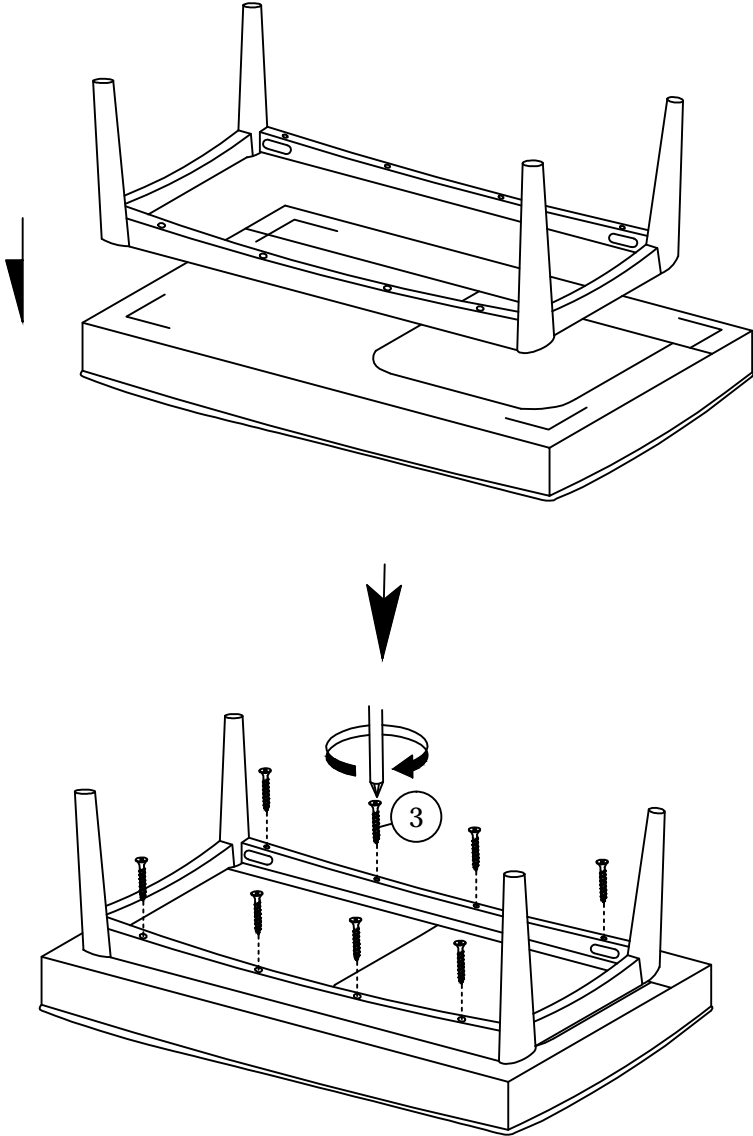

STEP 4

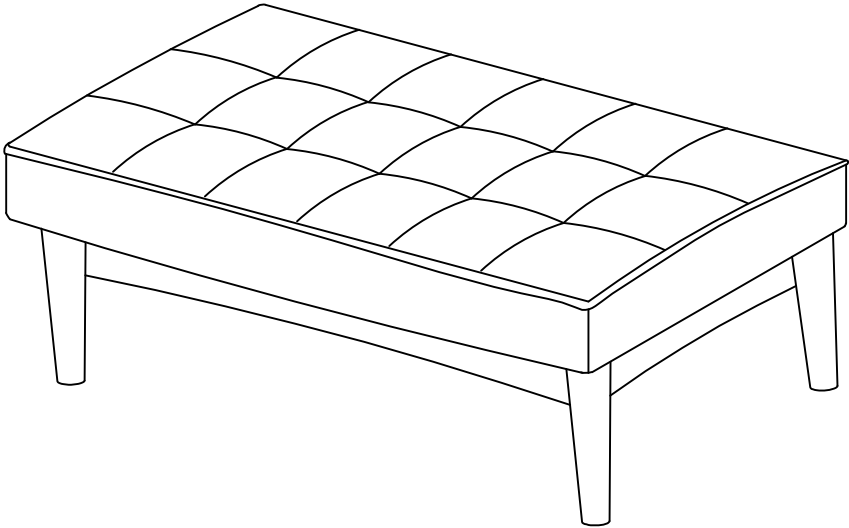

ASSEMBLY INSTRUCTIONS

Read this instruction carefully. See hardware and furniture part list for guidance. Be sure all parts are complete, before you assemble. Place all wooden furniture parts on a clean and flat soft surface to prevent from being scratched. Follow the figure to start assembling.

CAUTIONS : 1. Do not FULLY - TIGHTEN the nut or nut bolt until all nut or bolt is ready assembled.
2. Do not OVER - TIGHTEN the nut or bolt to avoid causing damages to the thread.
3. Keep all hardware parts out of reach of children.

NOTE : THE LIST AND QUANTITY SHOWN ARE FOR 1 UNIT ASSEMBLY.

PART LIST		
ITEM	DESCRIPTION	QTY
A	TABLE TOP	1 PC
B	LEGS	4 PCS

PART LIST		
ITEM	DESCRIPTION	QTY
1	JCBC BOLT M6 x 60mm 	8 PCS
2	M6 FLAT WASHER 	8 PCS
3	M6 SPRING WASHER 	8 PCS
4	M4 ALLEN KEY 	1 PC

STEP 1

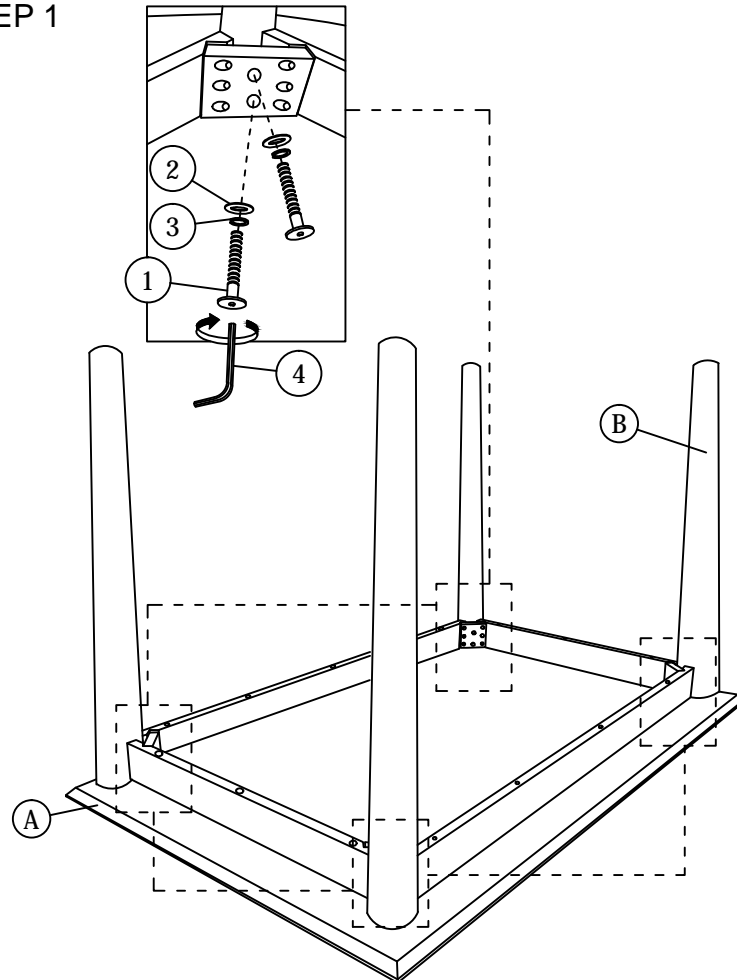

STEP 2

