

ASSEMBLY INSTRUCTION

PATIO DOUBLE LOUNGE

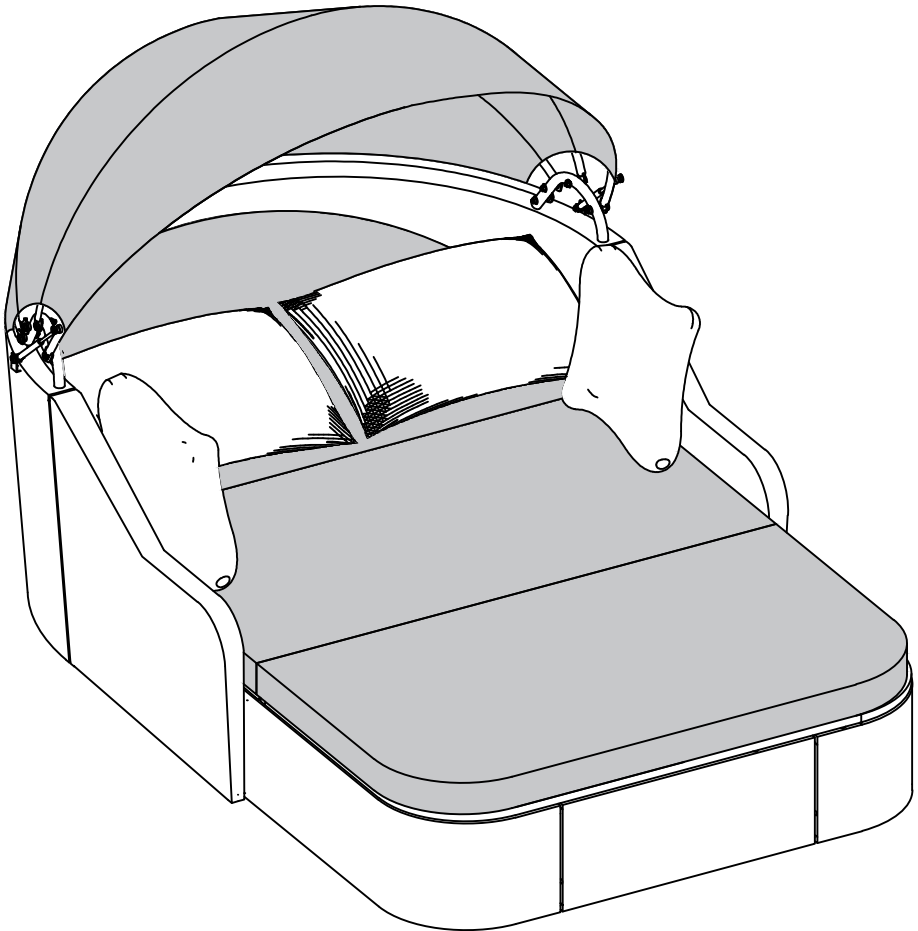

X1

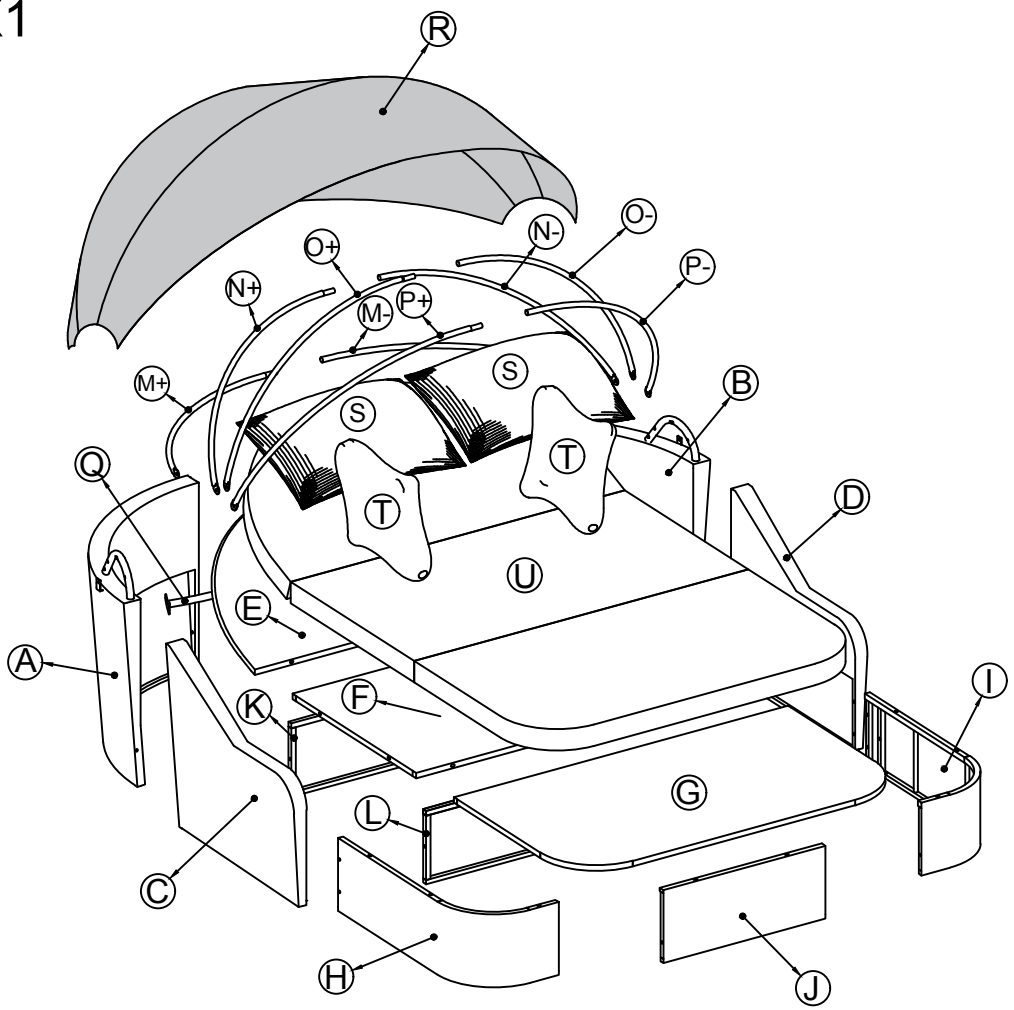

Note:

1. 50% Tighten before fixing all screws, Allen wrench is recommended instead of an electric drill.
2. Place the item on a flat ground to adjust and make sure it remains stable.
3. Tighten up all screw with tools gradually.
4. If screw are not aligned with holes during assembly, please loosen all the other screws to 50% and continue the assembly process.
5. If the item is not stable, please loosen all screws, adjust it on a flat ground and tighten up all screws again.
6. Note: If one or some screws are fully tighten during assembly, chances are the others will not be aligned with holes. In addition, all the holes are designed to be relatively larger to provide more space for the adjustment of the screws.

CARTON CONTENT:

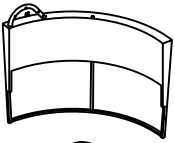

(A) x1

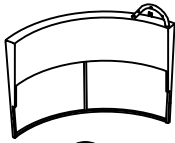

(B) x1

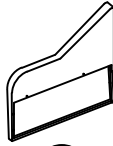

(C) x1

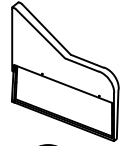

(D) x1

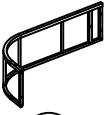

(H) x1



(I) x1



(J) x1



(S) x2



(T) x2

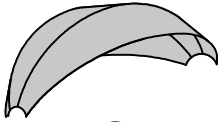

(R) x1

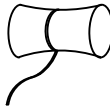

Hardware

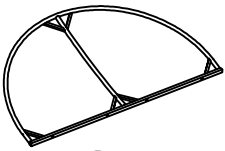

(E) x1

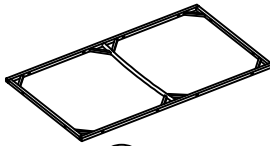

(F) x1

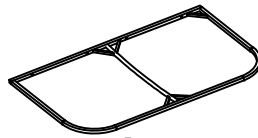

(G) x1

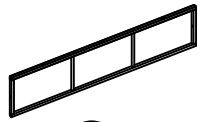

(K) x1

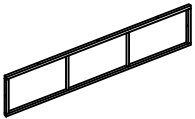

(L) x1



(M+) x1



(M-) x1



(N+) x1



(N-) x1



(O+) x1



(O-) x1



(P+) x1



(P-) x1





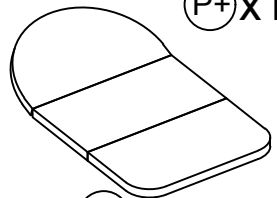





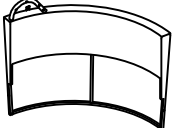

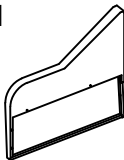
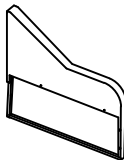
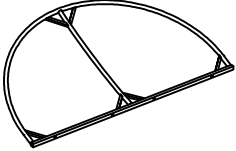
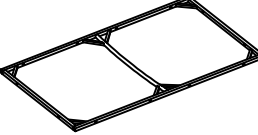
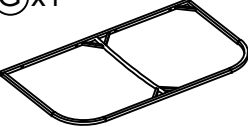
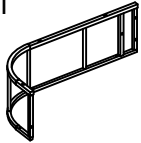
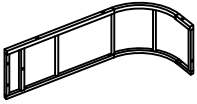
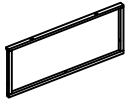
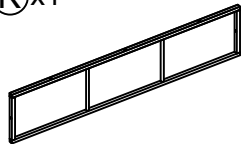
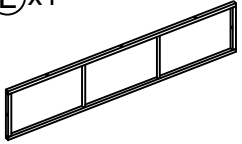



(Q) x1



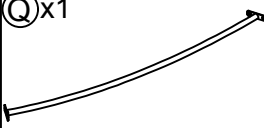

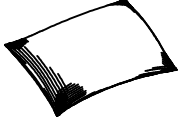

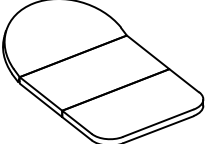









(U) x1

Part List:

<p>(A)x1</p>  <p>Back Right</p>	<p>(B)x1</p>  <p>Back Left</p>	<p>(C)x1</p>  <p>Arm Right</p>	<p>(D)x1</p>  <p>Arm Left</p>
<p>(E)x1</p>  <p>Front Seat Lounge</p>	<p>(F)x1</p>  <p>Middle Seat Lounge</p>	<p>(G)x1</p>  <p>Behind Seat Lounge</p>	<p>(H)x1</p>  <p>Side Right Lounge</p>
<p>(I)x1</p>  <p>Side Left Lounge</p>	<p>(J)x1</p>  <p>Front Lounge</p>	<p>(K)x1</p>  <p>Front Bare</p>	<p>(L)x1</p>  <p>Middle Bare</p>
<p>(M+)x1</p>  <p>Support M+</p>	<p>(M-)x1</p>  <p>Support M-</p>	<p>(N+)x1</p>  <p>Support N+</p>	<p>(N-)x1</p>  <p>Support N-</p>
<p>(O+)x1</p>  <p>Support O+</p>	<p>(O-)x1</p>  <p>Support O-</p>	<p>(P+)x1</p>  <p>Support P+</p>	<p>(P-)x1</p>  <p>Support P-</p>
<p>(Q)x1</p>  <p>Support Back</p>	<p>(R)x1</p>  <p>Covered</p>	<p>(S)x2</p>  <p>Back Cushion</p>	<p>(T)x2</p>  <p>Pillow Cushion</p>
<p>(U)x1</p>  <p>Seat Cushion</p>			

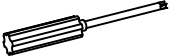
Hardware List:

<p>① x 4 pcs Extra 2 pcs</p>  <p>BOLT M6 x 20MM</p>	<p>② x 16 pcs Extra 2 pcs</p>  <p>BOLT M6 x 30MM</p>	<p>③ x 20 pcs Extra 2 pcs</p>  <p>BOLT M6 x 35MM</p>	<p>④ x 11 pcs Extra 2 pcs</p>  <p>BOLT M6 x 55MM</p>
<p>⑤ x 76 pcs Extra 5 pcs</p>  <p>FLAT WASHER M6</p>	<p>⑥ x 10 pcs Extra 2 pcs</p>  <p>WASHER M6 x 5MM</p>	<p>⑦ x 21 pcs Extra 2 pcs</p>  <p>NUT M6</p>	<p>⑧ x 10 pcs Extra 2 pcs</p>  <p>COVER NUT M6</p>
<p>⑨ x 1 pc</p>  <p>KEY</p>	<p>⑩ x 2 pcs</p>  <p>ALLEN KEY</p>	<p>⑪ x 2 pcs</p>  <p>GASLIFT</p>	<p>⑫ x 4 pcs Extra 2 pcs</p>  <p>SCREW</p>
<p>⑬ x 1 pc</p>  <p>SCREW DIVER</p>	<p>⑭ x 2 pcs Extra 1 pcs</p>  <p>WASHER M6 x 10MM</p>	<p>⑮ x 4 pcs Extra 2 pcs</p>  <p>BOLT M6 x 25MM</p>	

STEP 1

(B) x 1

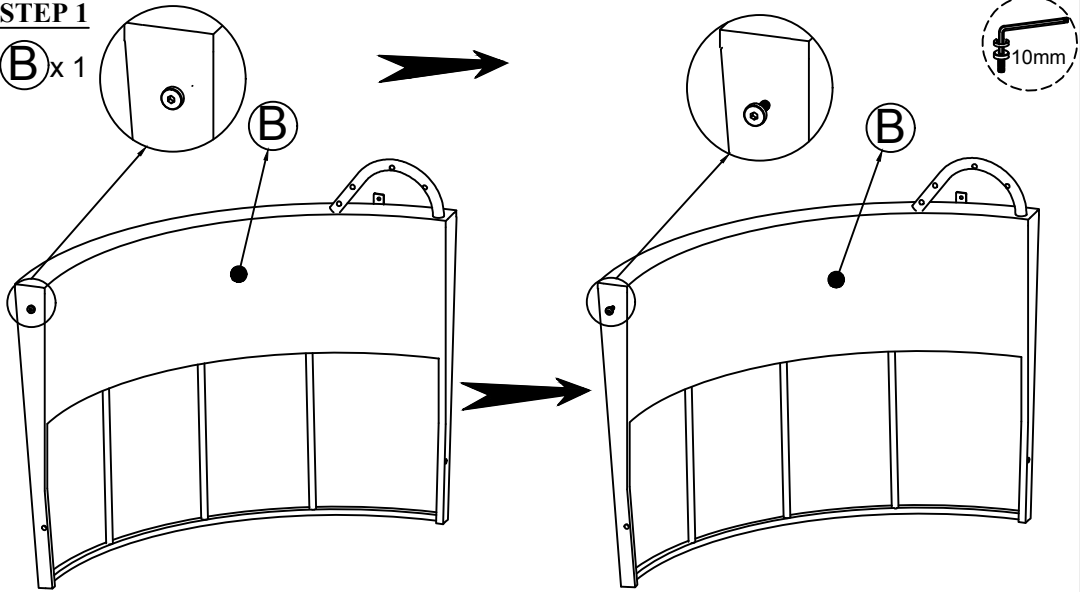

Use Allen key to loosen Bolt on the side of Back Left (B) about 10 mm.

STEP 2

(A) x 1

(4) x 1

(5) x 2

(7) x 1

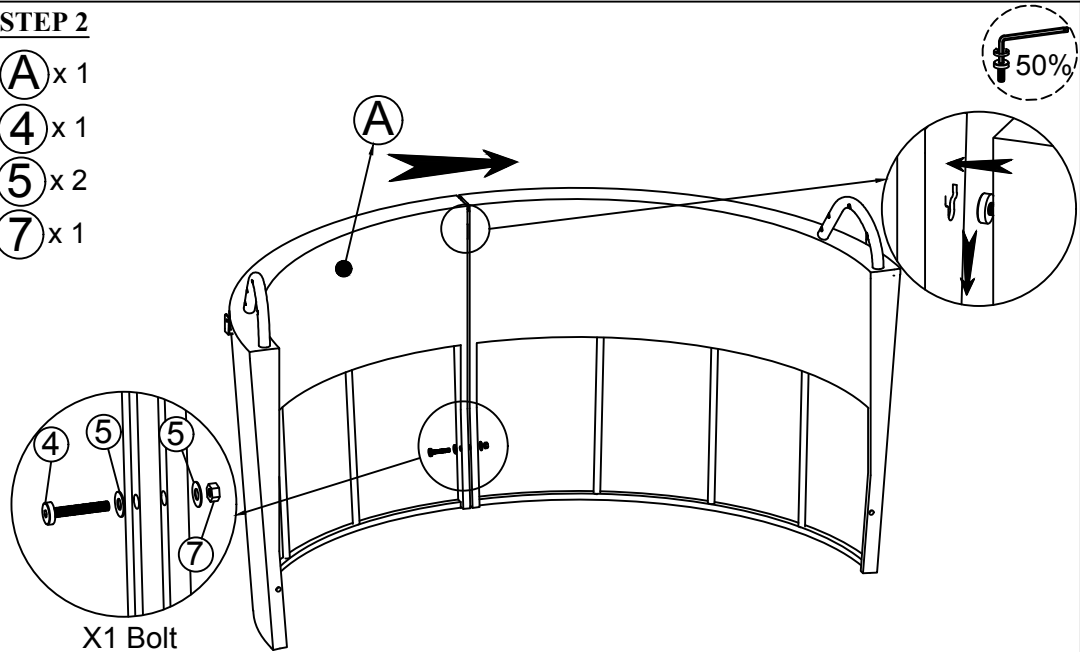

Connect The Part from Step 1 & Back Right (A), tighten Bolt (4), Flat Washer (5), nut (7) with Allen Key (10), Key (9).

STEP 3

- Ⓚ x 1
- ① x 4
- ⑤ x 4

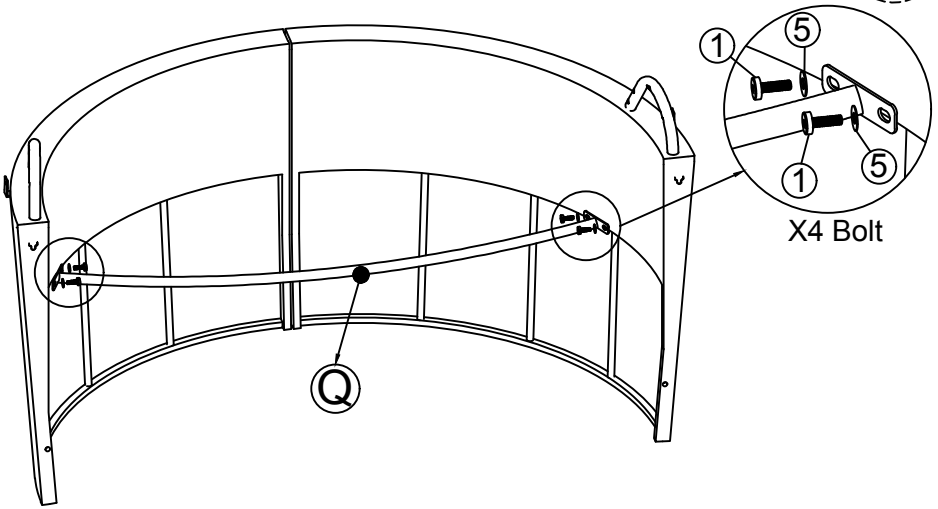

Connect The Part from Step 2 & Support Back (Q), tighten Bolt (1), Flat Washer (5) with Allen Key (10).

STEP 4

- Ⓒ x 1

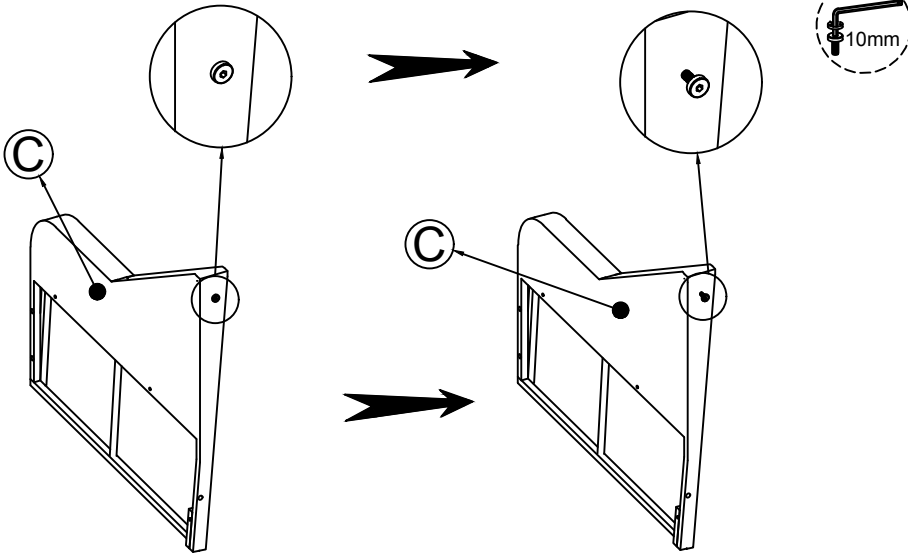

Use Allen key to loosen Bolt on the side of Arm Right (C) about 10 mm.

STEP 5

- ④ x 1
- ⑤ x 2
- ⑦ x 1

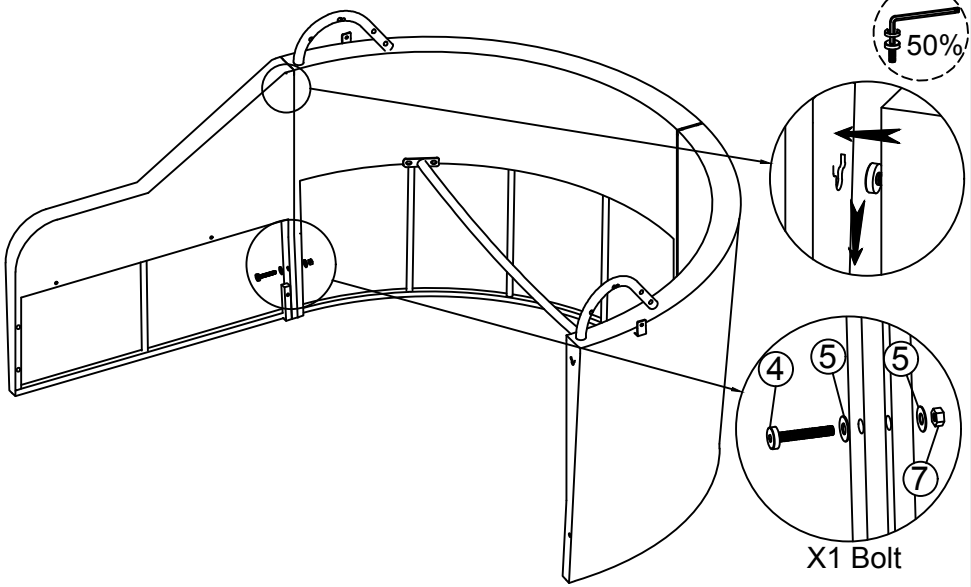

Connect The Part from Step 3 & Step 4, tighten Bolt (4), Flat Washer (5), Nut (7) with Allen Key (10), Key (9).

STEP 6

- ⓓ x 1

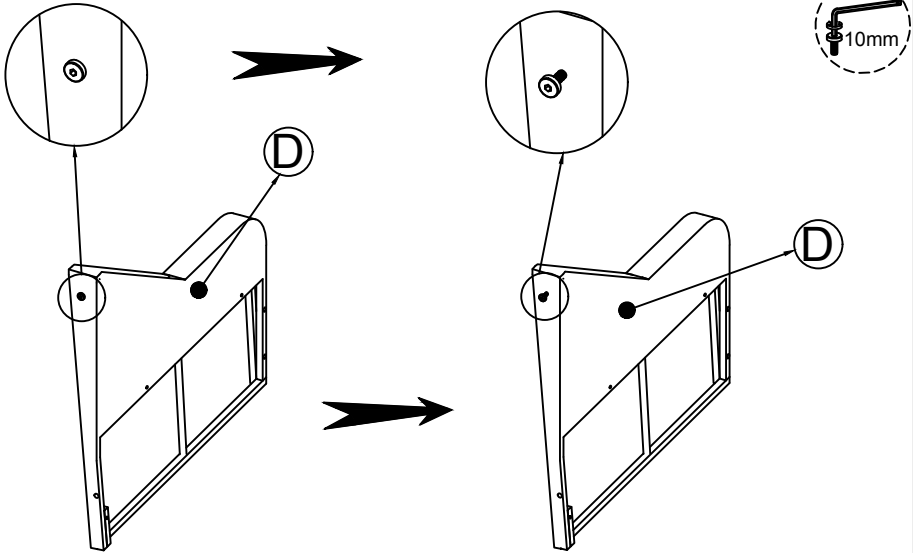

Use Allen key to loosen Bolt on the side of Arm Left (D) about 10 mm.

STEP 7

- (4)** x 1
- (5)** x 2
- (7)** x 1

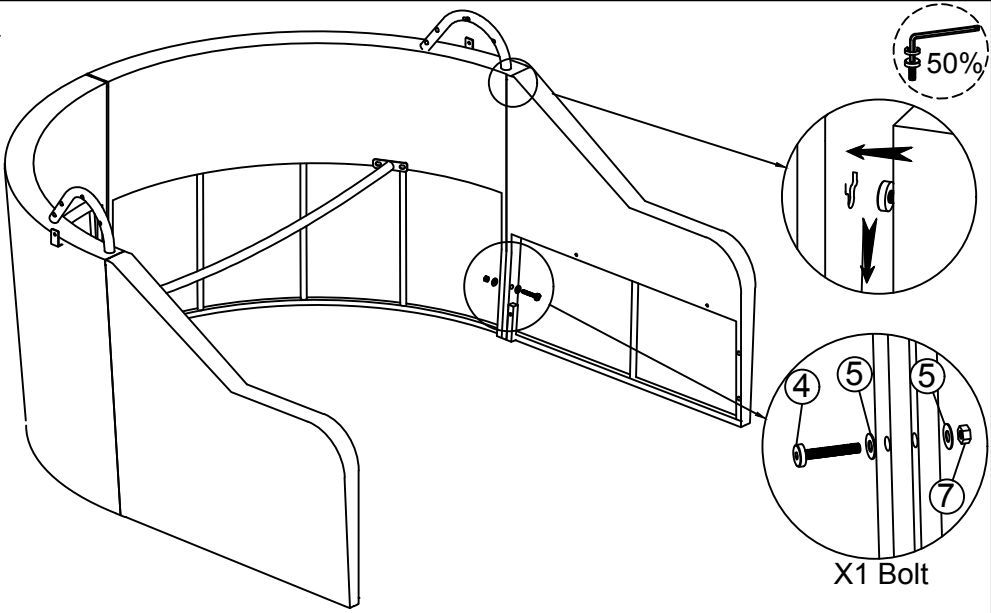

X1 Bolt

Connect The Part from Step 5 & Step 6, tighten Bolt (4), Flat Washer (5), Nut (7) with Allen Key (10), Key (9).

STEP 8

- (K)** x 1
- (2)** x 2
- (5)** x 2

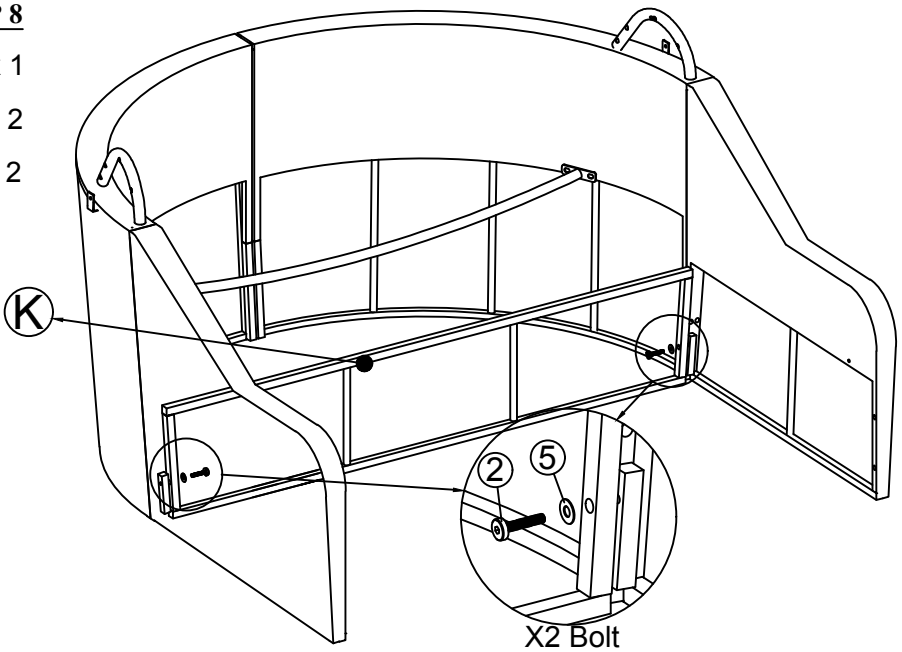

X2 Bolt

Connect The Part from Step 7 & Front Bare (K), tighten Bolt (2), Flat Washer (5) with Allen Key (10).

STEP 9

(E) x 1

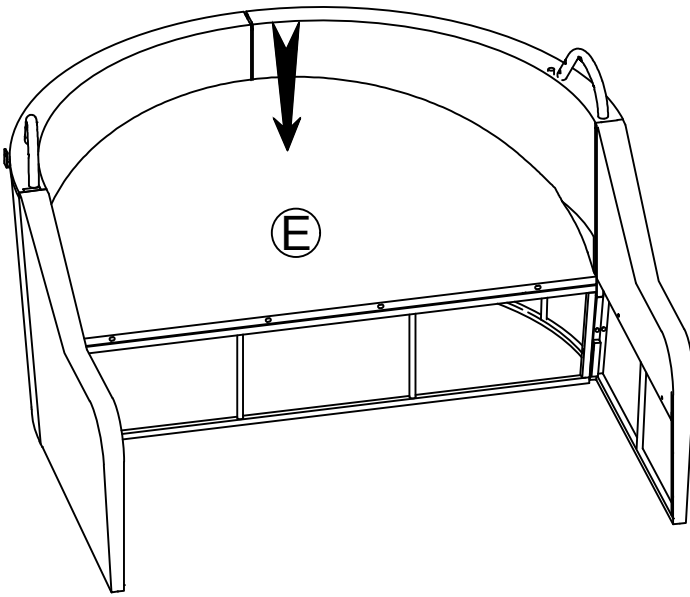

Connect The Part from Step 8 & Front Seat Lounge (E).

STEP 10

(2) x 3

(5) x 3

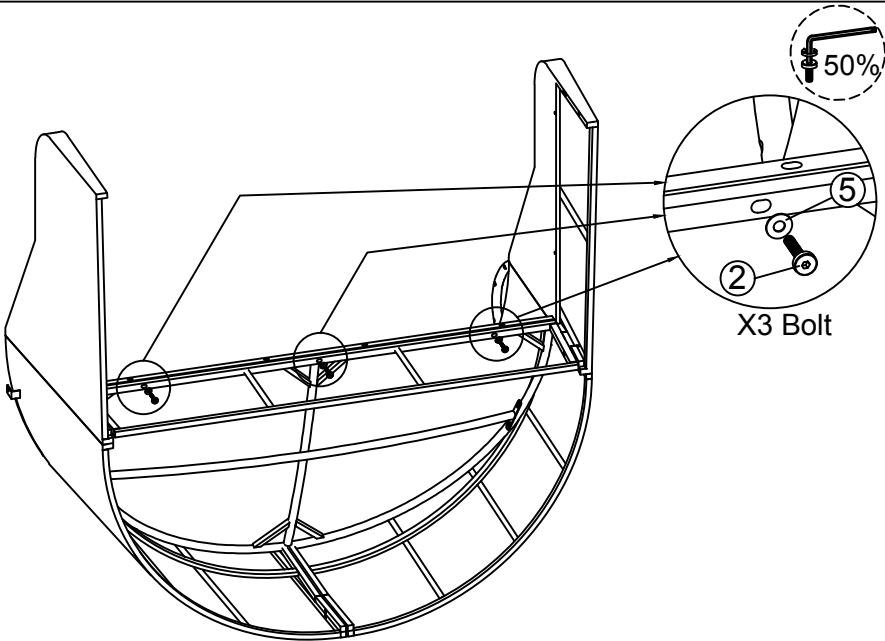

Connect The Part from Step 9, tighten Bolt (2), Flat Washer (5) with Allen Key (10).

STEP 11

- (F)** x 1
- (3)** x 2
- (4)** x 4
- (5)** x 10
- (7)** x 4

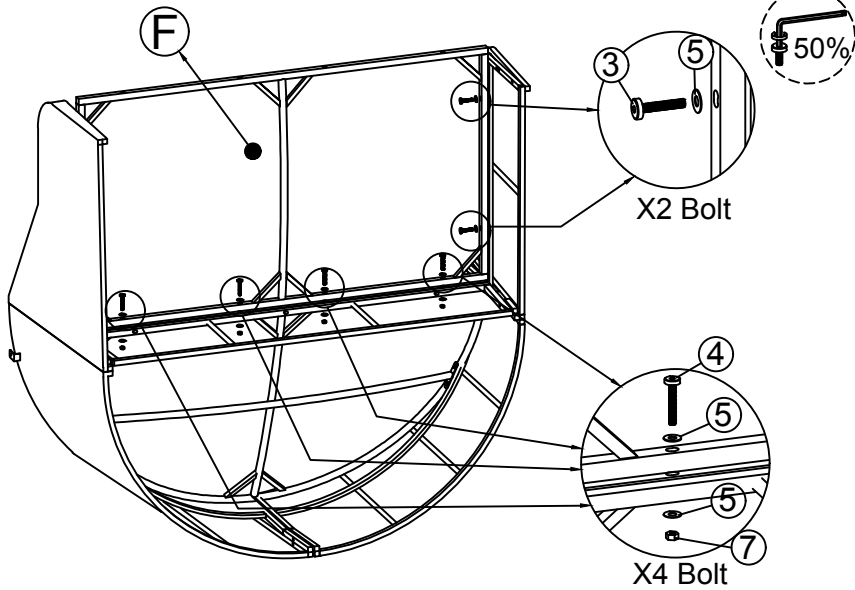

Connect The Part from Step 10 & Middle Seat Lounge (F), tighten Bolt (3),(4) Flat Washer (5), Nut (7) with Allen Key (10), Key (9).

STEP 12

- (3)** x 2
- (5)** x 2

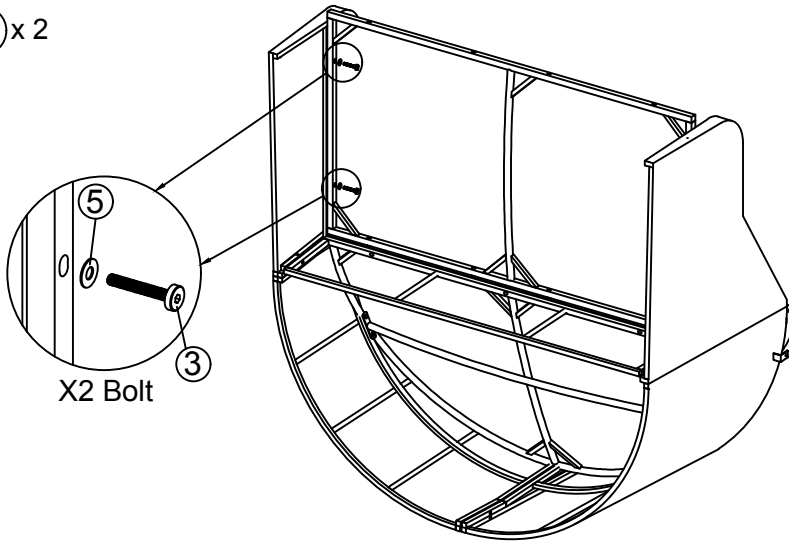

Connect The Part from Step 11, tighten Bolt (3), Flat Washer (5) with Allen Key (10).

STEP 13

- ⓐ x 1
- ⓑ x 4
- ⓒ x 8
- ⓓ x 4

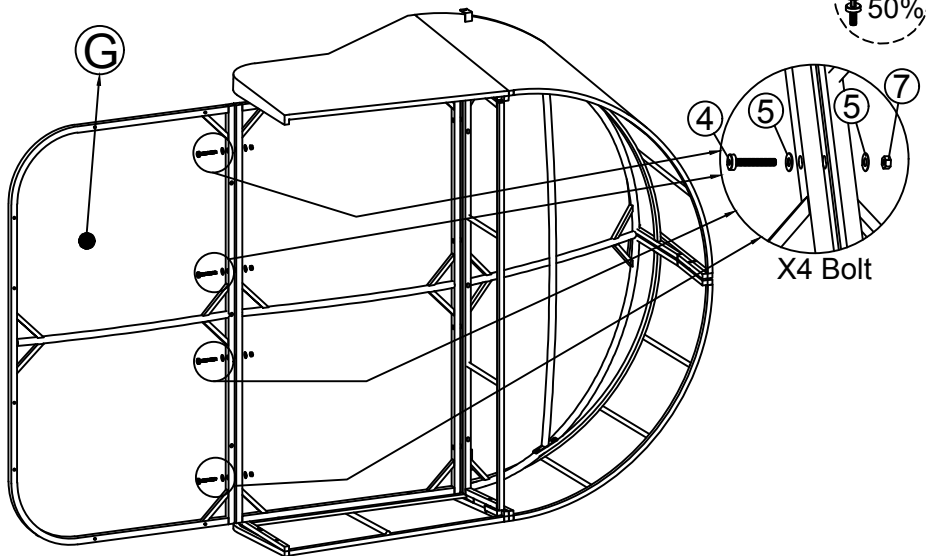

Connect The Part from Step 12 & Behind Seat Lounge (G), tighten Bolt (4), Flat Washer (5), Nut (7) with Allen Key (10), Key (9).

STEP 14

- Ⓧ x 1
- Ⓨ x 2
- Ⓩ x 3
- Ⓛ x 5

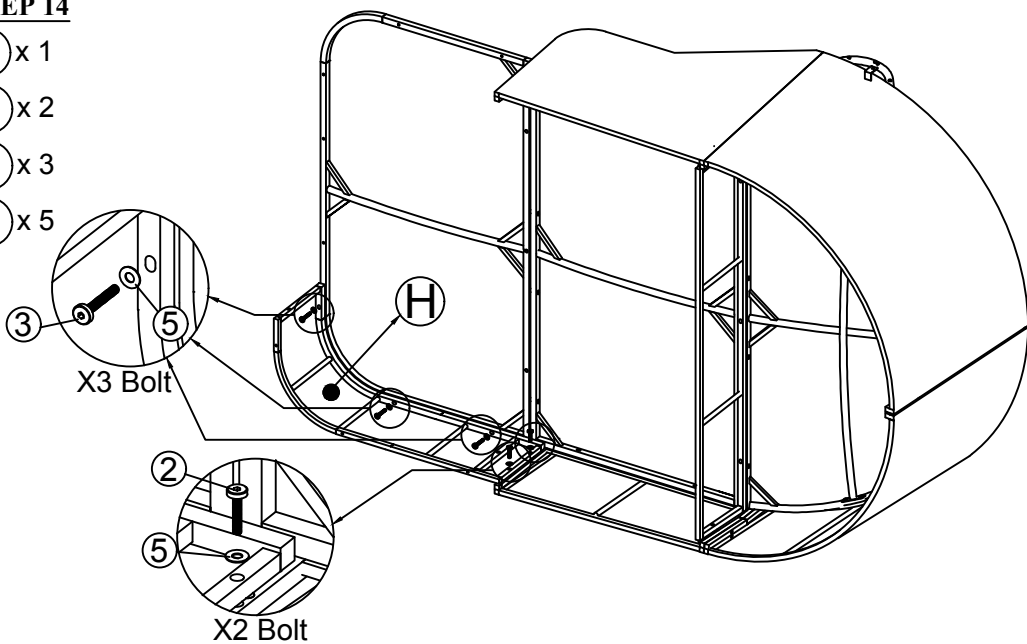

Connect The Part from Step 13 & , Side Right Lounge (H), tighten Bolt (2), (3), Flat Washer (5) with Allen Key (10).

STEP 15

- ① x 1
- ② x 2
- ③ x 3
- ⑤ x 5

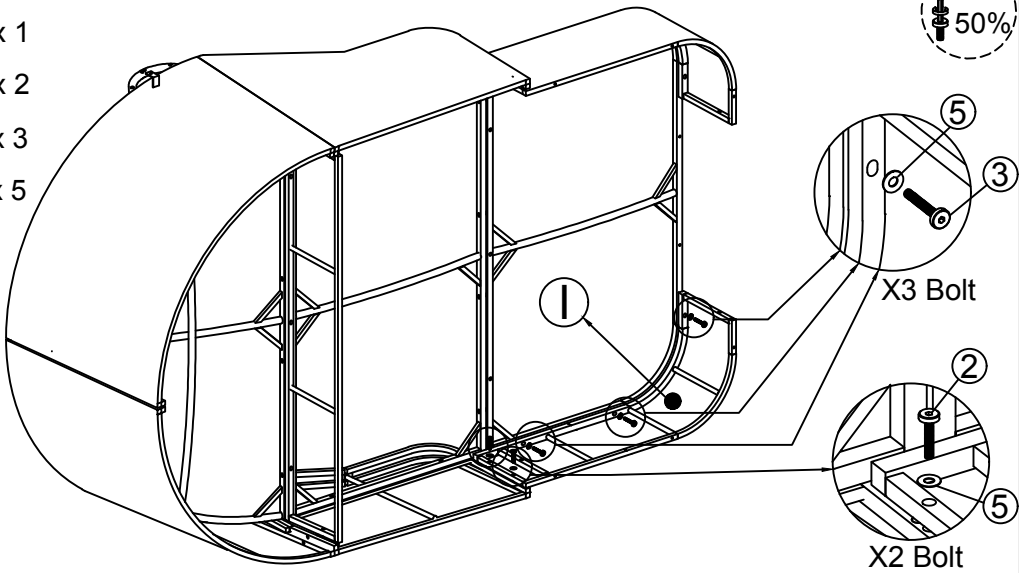

Connect The Part from Step 14 & Side Left Lounge (I), tighten Bolt (2), (3), Flat Washer (5) with Allen Key (10).

STEP 16

- ① x 1
- ② x 2
- ③ x 2
- ⑤ x 4

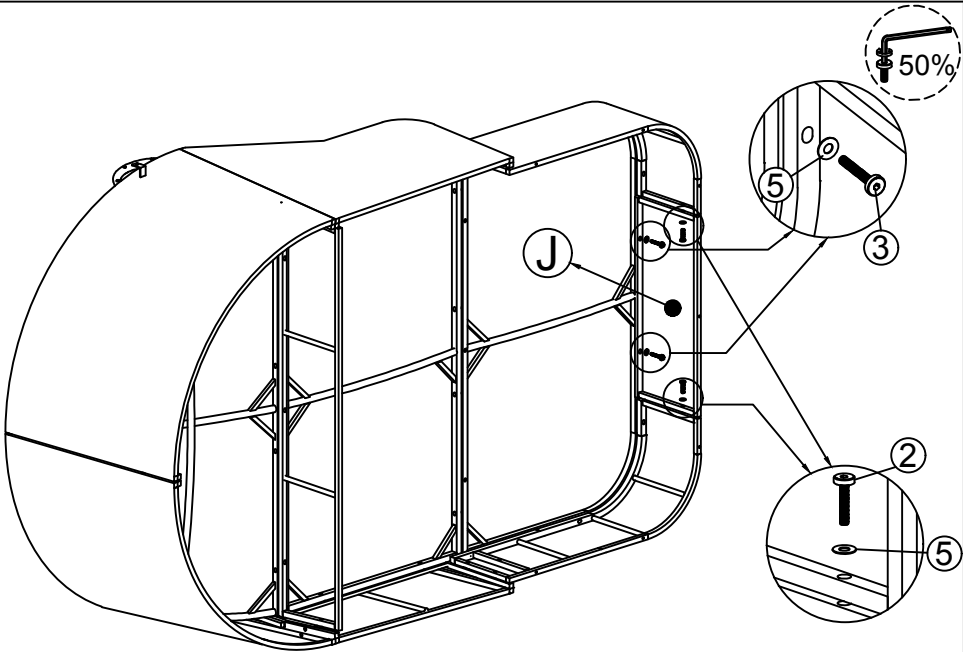

Connect The Part from Step 15 & Front Lounge (J), tighten Bolt (2), (3), Flat Washer (5) with Allen Key (10).

STEP 17

- (L) x 1
- (2) x 5
- (5) x 5

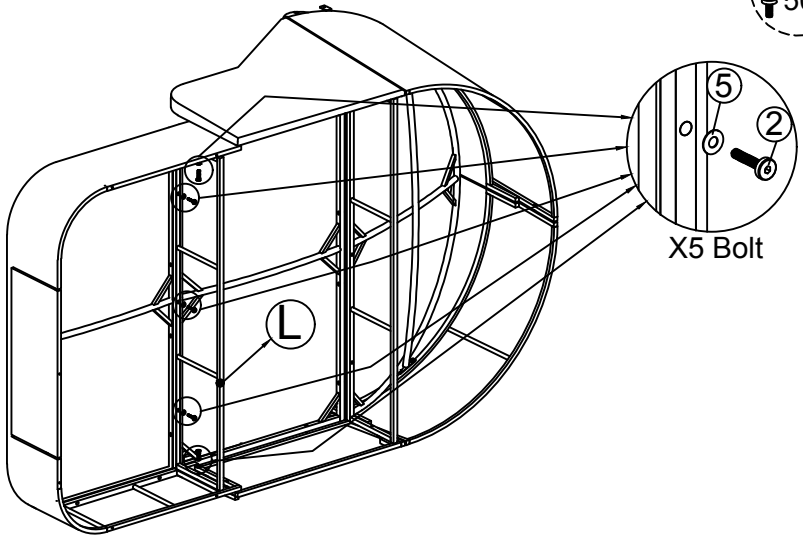

Connect The Part from Step 16 & Middle Bare (L), tighten Bolt (2), Flat Washer (5) with Allen Key (10).

STEP 18

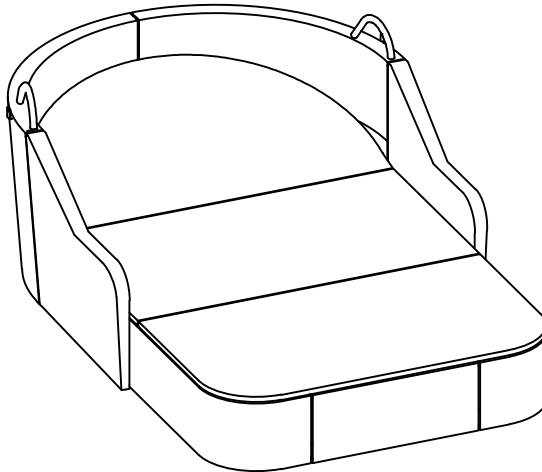

Put the Lounge upright and make sure all legs are level, then firmly tighten Bolts with Allen Key (10)

STEP 19

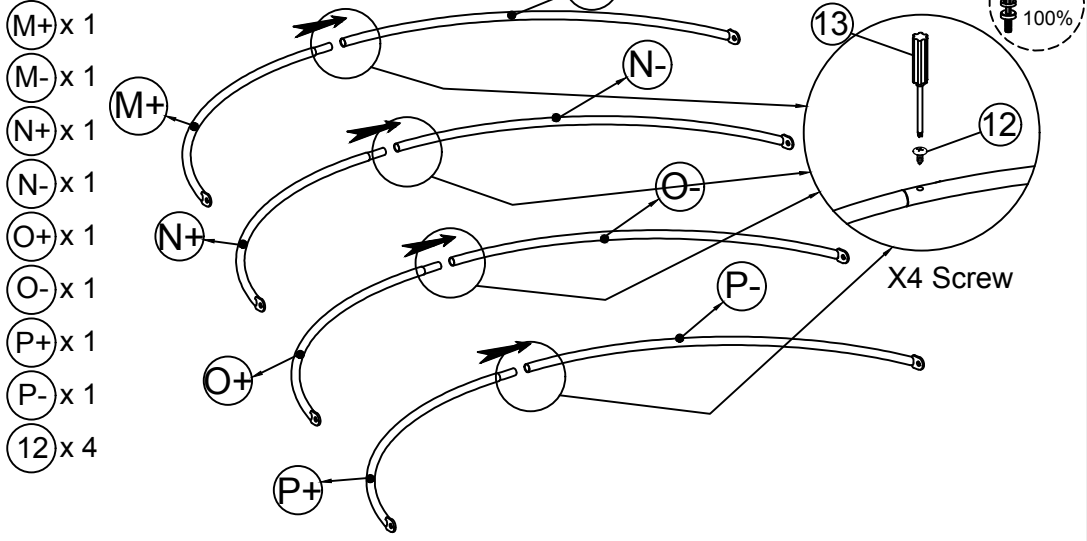

Connect The Support M+ & Support M- , Support N+ & Support N- , Support O+ & Support O- , Support P+ & Support P-. tighten Screw (12) with Screw Driver (13).

STEP 20

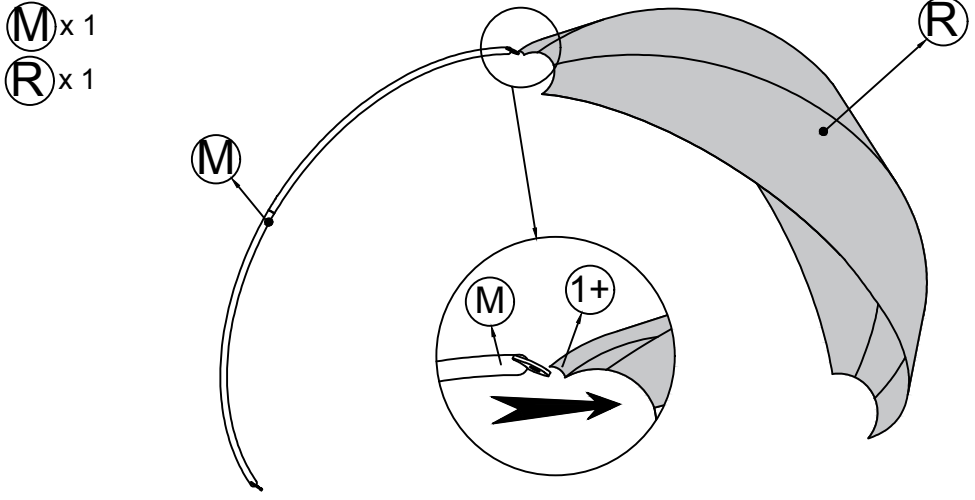

Connect The Support M & Covered (R).

STEP 21

(N) x 1

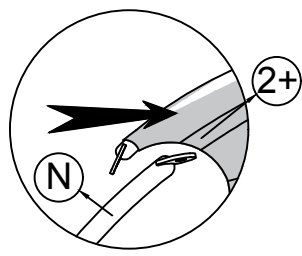
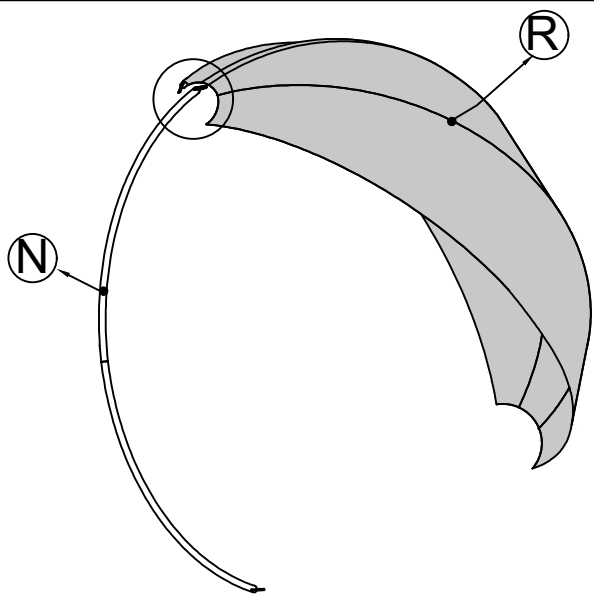

Connect The Part from Step 20 & Support (N)

STEP 22

(O) x 1

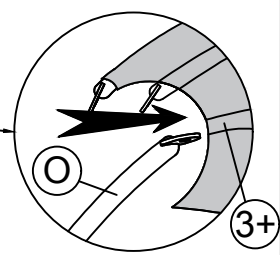
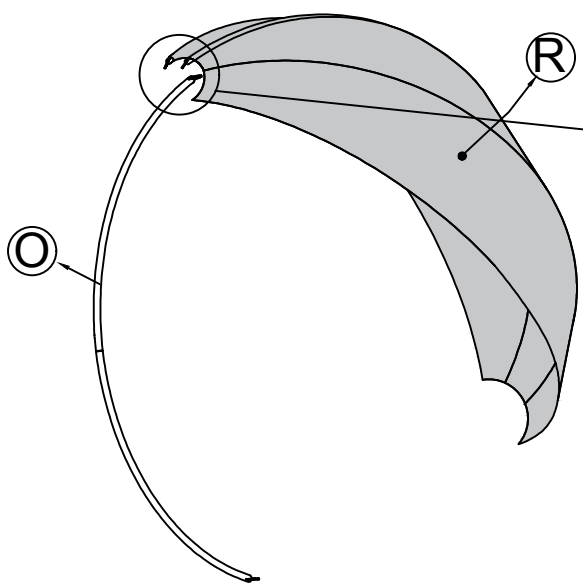

Connect The Part from Step 21 & Support (O)

STEP 23

(P) x 1

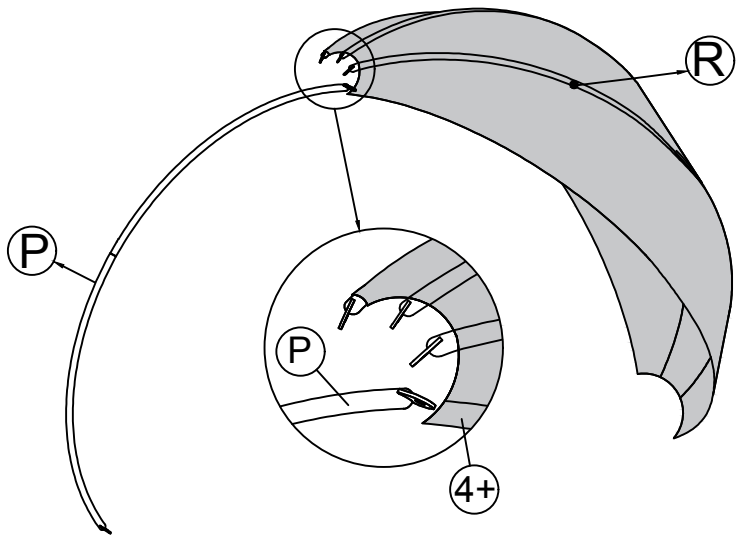

Connect The Part from Step 22 & Support (P)

STEP 24

(3) x 8

(5) x 16

(6) x 8

(7) x 8

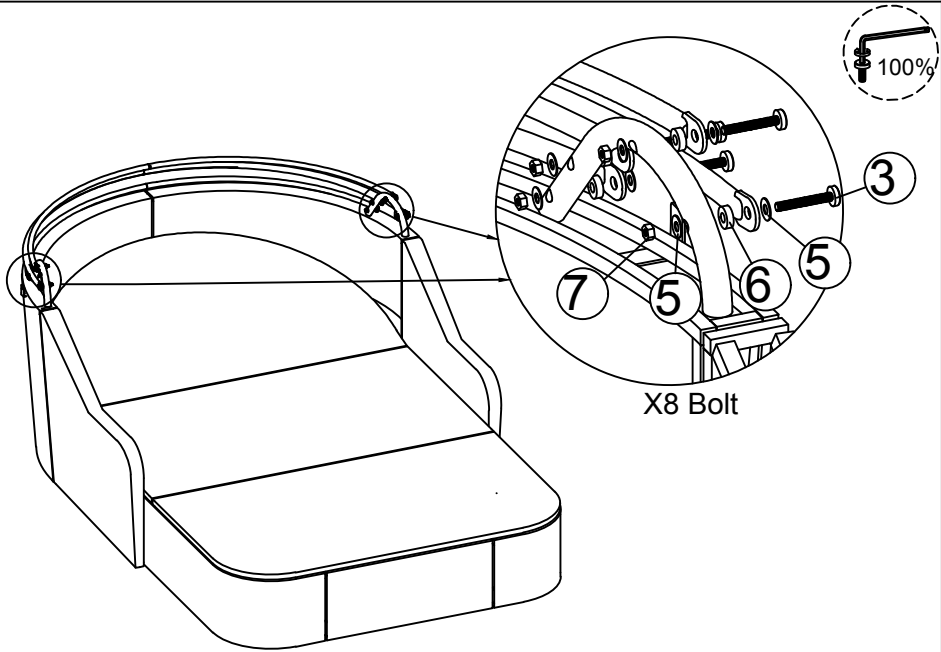

Connect The Part from Step 18 & Step 23, tighten Bolt (3), Flat Washer (5), Washer (6), Nut (7) with Allen Key (10), Key (9).

STEP 25

- 5** x 6
- 6** x 2
- 7** x 2
- 11** x 2
- 14** x 2
- 15** x 4

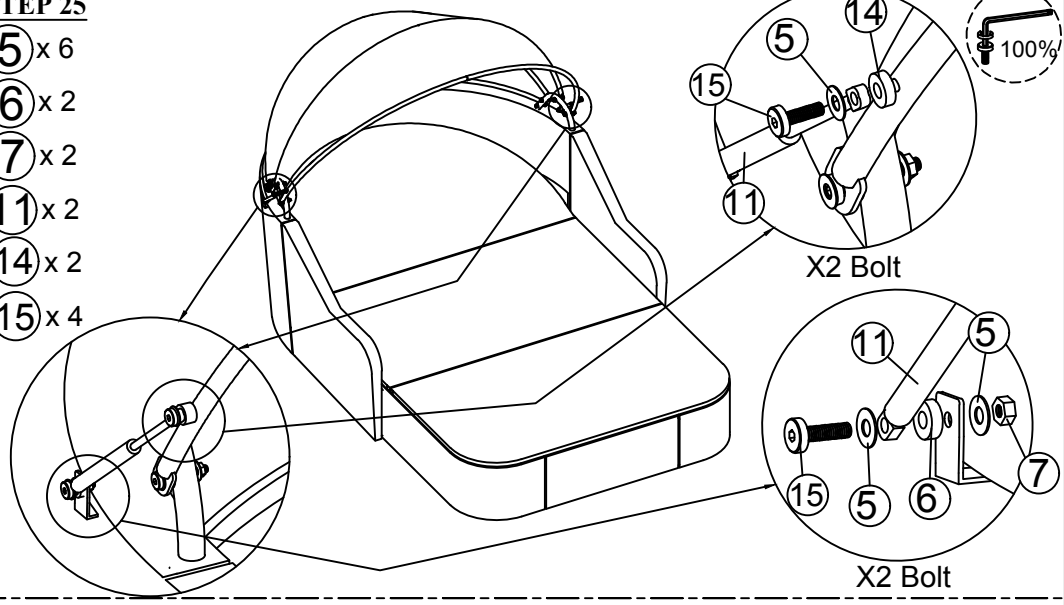

X2 Bolt

X2 Bolt

Connect The Part from Step 14 & Gaslift (11), tighten Bolt (15), Flat Washer (5), Washer (6),(14) Nut (7) with Allen Key (10), Key (9).

STEP 26

- 8** x 10

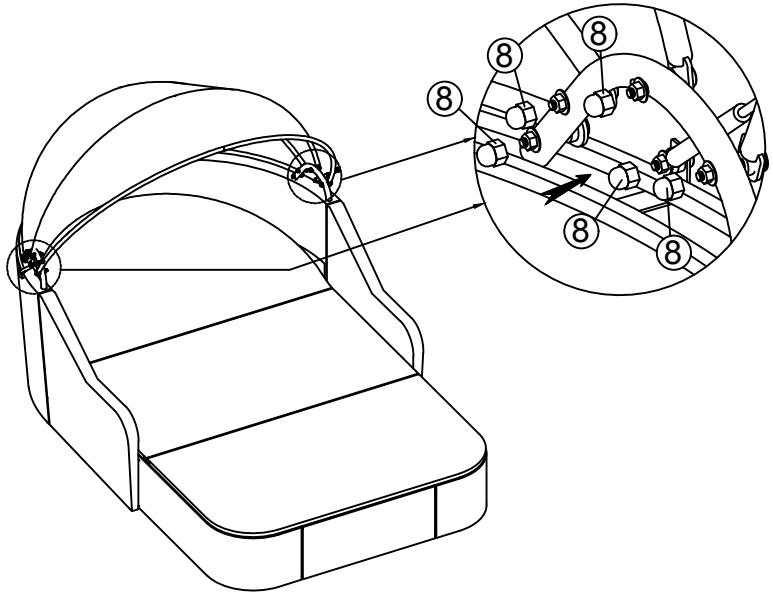

Connect The Part from STEP 25 & Cover Nut (8).

STEP 27

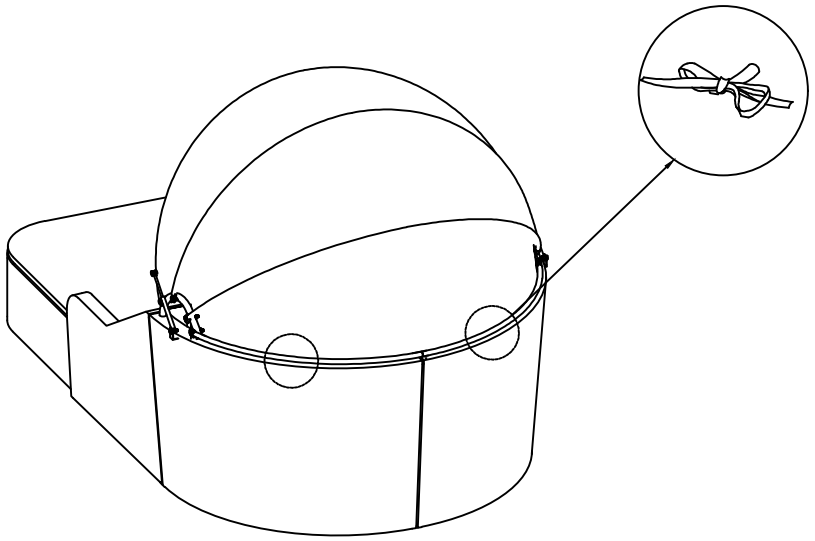

Stick string to Covered to Back Lounge.

STEP 28

U x 1

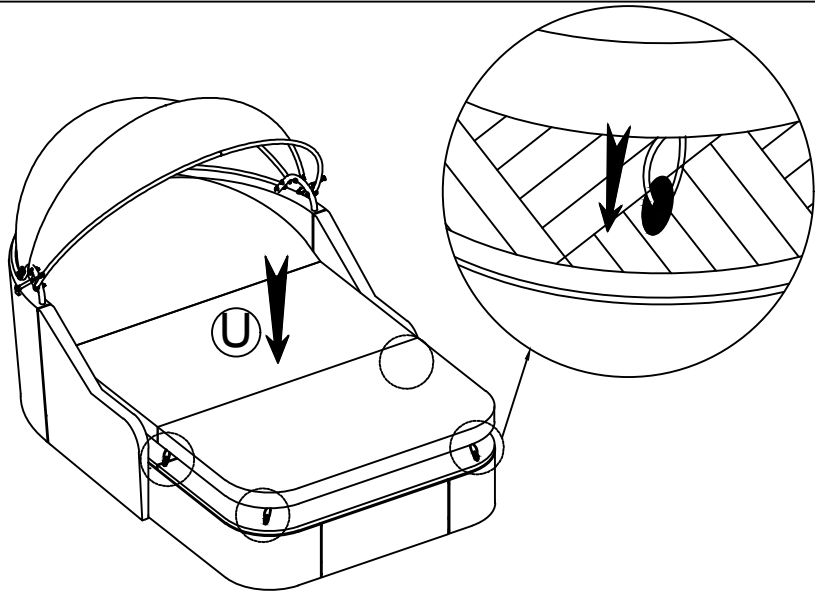

Put on Seat Cushion (U) to Lounge. Stick string to Lounge .

STEP 29

(S) x 2

(T) x 2

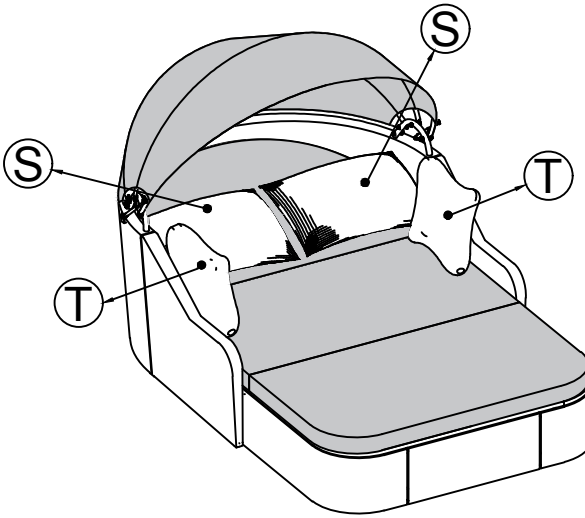

Put on Back Cushion (S) & Pillow Cushion (T) to Lounge.

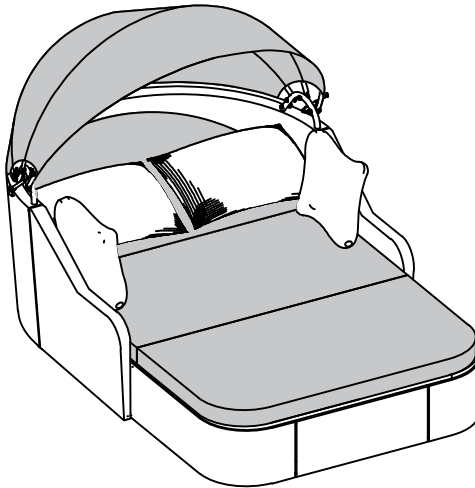

Finish Lounge