

Parts List For Bed

BRIDGEPORT BED CARTON

- (7) HEADBOARD PANEL-1
- (8) HEADBOARD BOTTOM RAIL-1
- (9) LEFT HEADBOARD POST-1
- (10) RIGHT HEADBOARD POST-1
- (11) FOOTBOARD-1
- (12) END CROSS SLAT-2
- (13) CENTER CROSS SLAT-2
- (14) SUPPORT LEGS-4
- NOTE: SUPPORT LEGS FOR (6/0-6/6)-6

BRIDGEPORT BED SIDE RAILS CARTON

- (15) SIDE RAIL-2
- (16) CENTER SUPPORT RAIL-1

HARDWARE BAG FOR 5/0

HARDWARE BAG FOR 6/0-6/6

- (1) 10MM X 40MM WOOD DOWELS-8
- (2) 1/4-20 X 1 1/2" FLAT ALLEN HEAD SCREW-14 FOR (5/0)
18 FOR (6/0-6/6)
- (3) 1/4 ID X 5/8" OD FLAT METAL WASHER-16 FOR (5/0)
18 FOR (6/0-6/6)
- (4) 1/4-20 X 3/4" FLAT ALLEN HEAD SCREW-8
- (5) #4 X 35MM PHILLIPS HEAD WOOD SCREW-10
- (6) ALLEN WRENCH-1

REQUIRED TOOLS:

PHILLIPS SCREW DRIVER
(NOT INCLUDED)

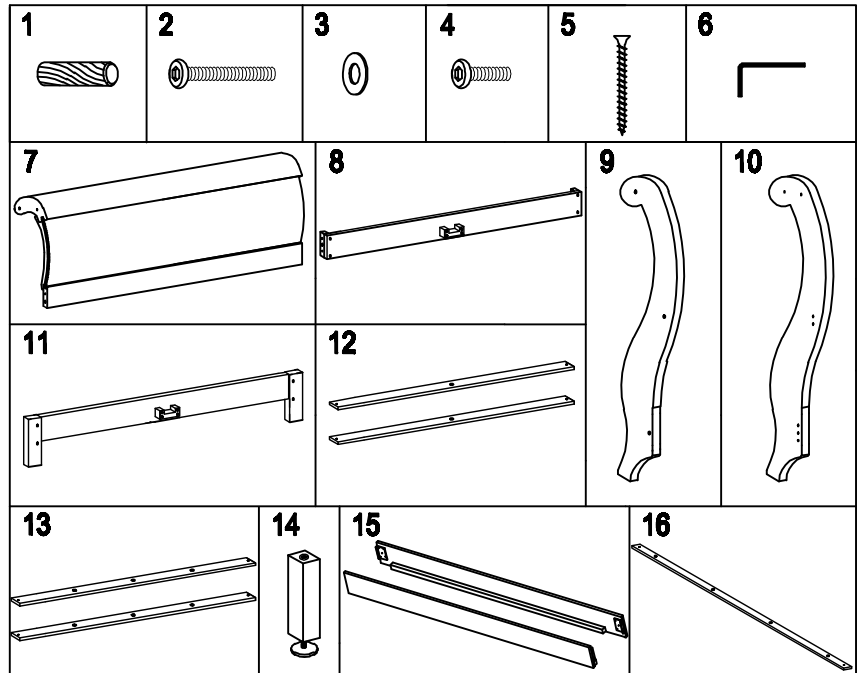
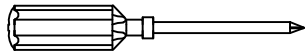

SAVE ALL PACKAGING MATERIALS UNTIL PRODUCT IS FULLY ASSEMBLED. HARDWARE AND SMALL PIECES MAY NOT BE SEEN AND COULD BE ACCIDENTALLY DISCARDED WITH PACKAGING MATERIALS.

Instruction Sheet

Step 1- Assembly of Headboard Panel.

- Insert wood dowel (1) into pilot holes on headboard panel (7) and headboard bottom rail (8). SEE FIGURE 1
- Align wood dowels (1) with pilot holes on left headboard post (9) and right headboard post (10).
- Secure headboard post (9 & 10) with screw (2). Use Allen wrench (6). SEE FIGURE 1

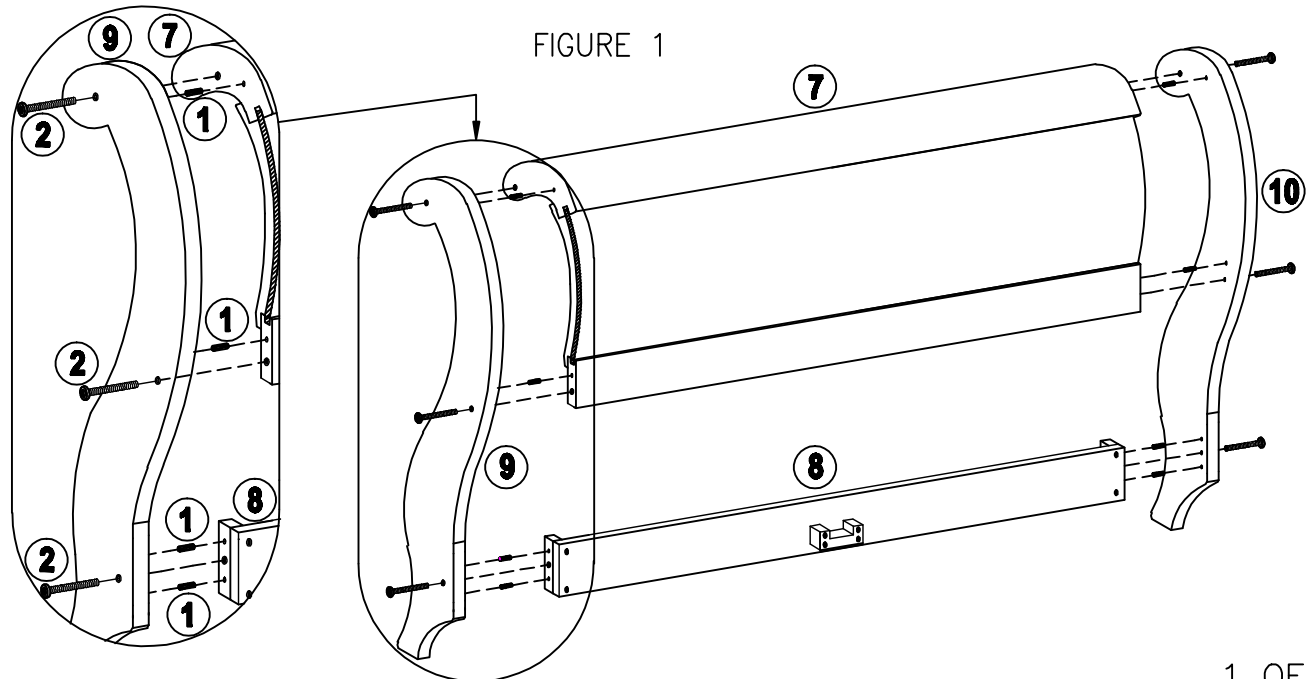

Instruction Sheet

Step 2- Assembly of Side Rails.

- Align holes on side rail (15) metal bracket with threaded insert on headboard bottom rail (8). SEE FIGURE 2
- Secure side rail (15) with flat metal washer (3) and screw (4). Use Allen wrench (6). DO NOT TIGHT SCREWS COMPLETELY.
- Repeat same step with footboard panel (11).

FIGURE 2

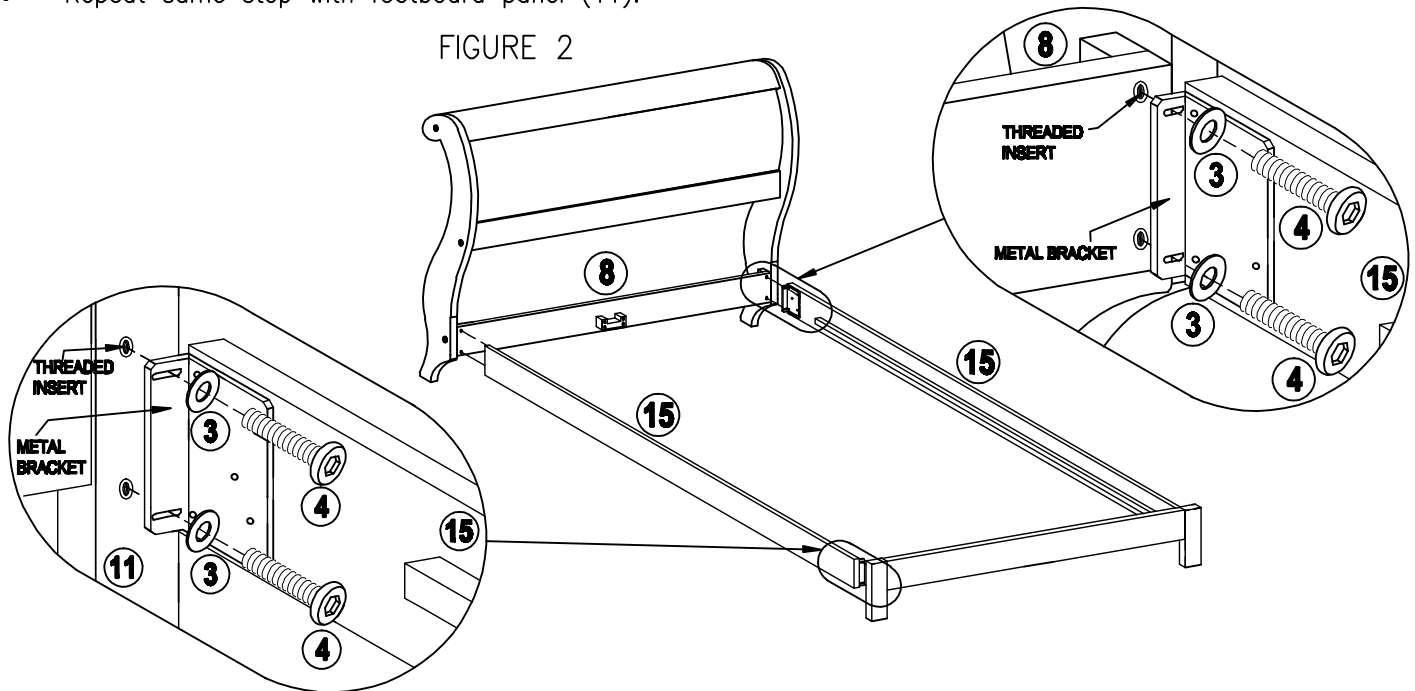

Step 3- Assembly of Center Support Rails.

- Place Center support rail (16) over headboard bottom rail (8) and footboard panel (11) wood support block. SEE FIGURE 3
- Secure center support rail (16) with phillips head wood screw (5). Use phillips screwdriver.
NOTE: Attach the support leg (14) to center support rail (16) if you have 6/0 and 6/6 size Bed.
- Secure support leg (14) with flat metal washer (3) and screw (2). SEE FIGURE 3
NOTE: Reposition adjustable glide on support leg as needed.
- Use Allen wrench (6).

FIGURE 3

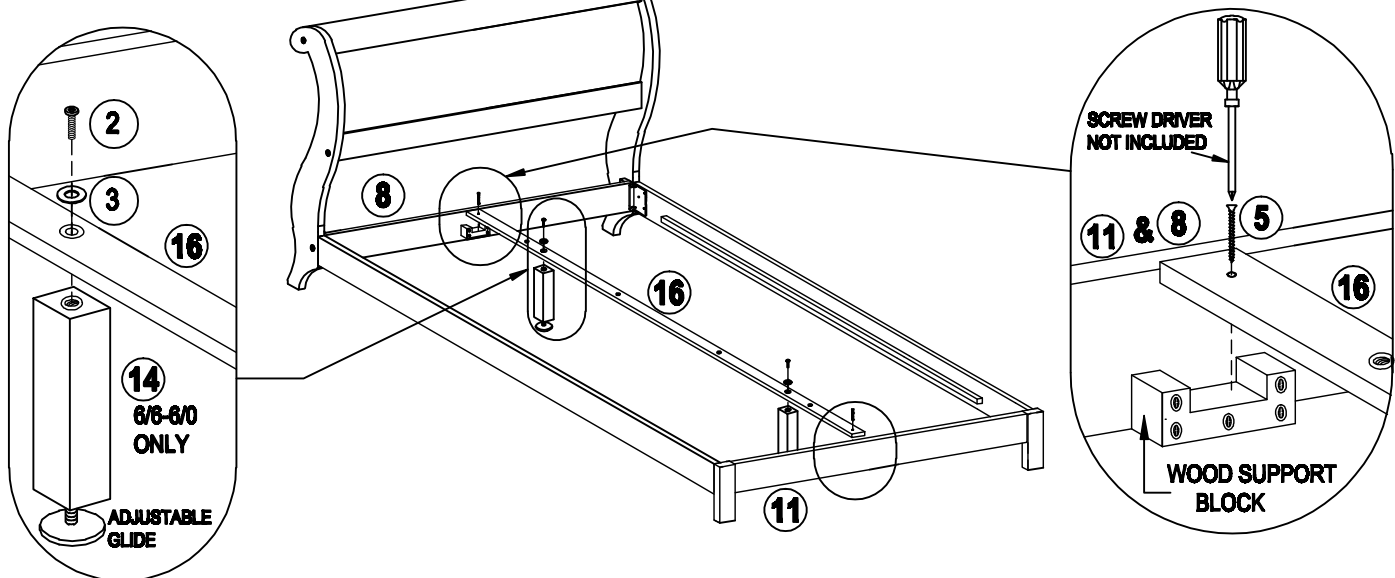

Instruction Sheet

Step 4- Assembly of Support legs and Slats.

- Align threaded inserts on support legs (14) with pilot holes on center cross slats (13). SEE FIGURE 4
- Secure support legs (14) with screw (2) and flat metal washer (3). Use Allen wrench (6).
- Place end cross slats (12) and center cross slats (13) over center support rail (16). SEE FIGURE 5
- Align pilot holes on slats (12&13) with threaded inserts on center support rail (16).
- Secure slats (12&13) with screw (2) and flat metal washer (3). Use Allen wrench (6).
- Secure slats (12&13) into cleat on side rail (15) with phillips head wood screw (5).
Use phillips screwdriver. SEE FIGURE 6
- NOTE: Reposition adjustable glide on support leg as needed.
- Now tighten completely all screws (4). Use Allen wrench (6). SEE FIGURE 2

FIGURE 5

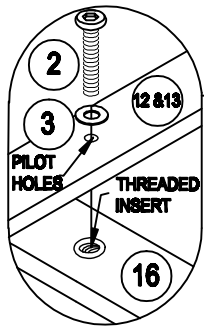

FIGURE 4

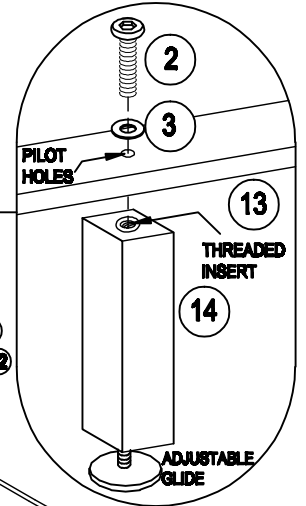
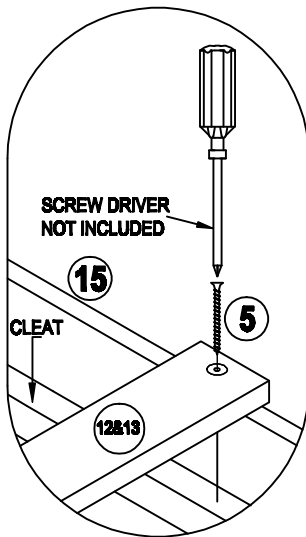
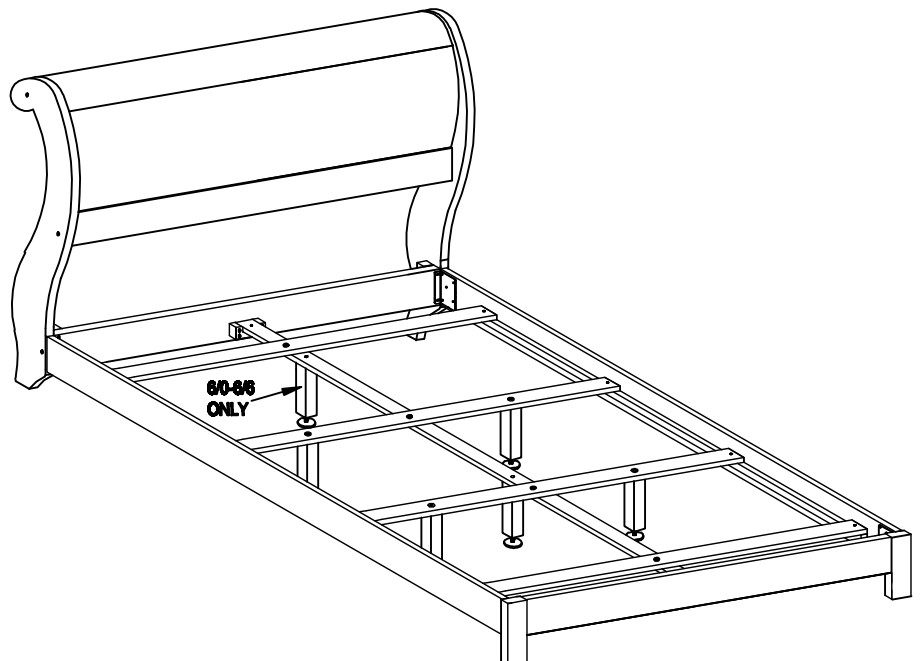

FIGURE 6



PRODUCT FULLY ASSEMBLED



FOR ASSISTANCE IN ASSEMBLY ONLY OF THIS PRODUCT, CALL OUR HELP DESK. PLEASE HAVE THE STYLE NUMBER AVAILABLE BEFORE YOU CALL. (STYLE # OR NAME CAN BE FOUND ON PACKING CARTON OR SALES RECEIPT.) OUR PRODUCT IS INSPECTED TO ENSURE IT IS IN GOOD CONDITION. IF YOUR FURNITURE APPEARS TO HAVE BEEN DAMAGED IN SHIPMENT OR YOU ARE IN NEED OF REPLACEMENT PARTS PLEASE CONTACT THE DEALER FROM WHOM YOU PURCHASED THE PRODUCT.