



# ASSEMBLY INSTRUCTIONS

MODEL:

B1862-312 - ROWLAND 5/0 QUEEN SOLID WOOD  
ARCHED HEADBOARD-WALNUT

B1862-330 - PLATFORM BEDS

Thank you for purchasing this quality product. Be sure to check all packing materials carefully for small parts, which may have come loose inside the carton during shipment. Identify and count all items and compare with the parts list and/or hardware list shown below.

Please read all instructions carefully. See the hardware and furniture part listing for guidance. Be sure you have all parts listed before beginning assembly. Place all wooden parts on a clean, flat surface to protect the finish from scratches. Follow the diagram to assemble.

**CAUTION**

1. Do not fully tighten the nuts or bolts until the table is fully assembled.
2. Please tighten by hand, not by a drill. Overtightening will damage threads. Do not overtighten.
3. Keep all hardware out of the reach of children.

PARTS LIST			
ITEM	DESCRIPTION	SKETCH	QTY
BOX 1 PARTS LIST			
A	HEADBOARD		1 PC
B	HEADBOARD LEG (L)		1 PC
C	HEADBOARD LEG (R)		1 PC

PARTS LIST			
ITEM	DESCRIPTION	SKETCH	QTY
BOX 2 PARTS LIST			
D	FOOTBOARD LEG (L)		1 PC
E	FOOTBOARD LEG (R)		1 PC
F	PANEL		2 PCS
G	SIDE RAIL		2 PCS
H	SLAT SUPPORT		1 PC
I	CENTER SUPPORT		3 PCS
J	SLAT		2 SET

WEIGHT CAPACITY	600 LBS
-----------------	---------

HARDWARE DIMENSIONS VERIFICATION TOOL

# ASSEMBLY INSTRUCTIONS

MODEL:

B1862-312 - ROWLAND 5/0 QUEEN SOLID WOOD  
ARCHED HEADBOARD-WALNUT













B1862-330 - PLATFORM BEDS

Thank you for purchasing this quality product. Be sure to check all packing materials carefully for small parts, which may have come loose inside the carton during shipment. Identify and count all items and compare with the parts list and/or hardware list shown below.

Please read all instructions carefully. See the hardware and furniture part listing for guidance. Be sure you have all parts listed before beginning assembly. Place all wooden parts on a clean, flat surface to protect the finish from scratches. Follow the diagram to assemble.

**CAUTION**

1. Do not fully tighten the nuts or bolts until the table is fully assembled.
2. Please tighten by hand, not by a drill. Overtightening will damage threads. Do not overtighten.
3. Keep all hardware out of the reach of children.

HARDWARE LIST (BOX 1)				HARDWARE LIST (BOX 1)			
ITEM	DESCRIPTION	SKETCH	QTY	ITEM	DESCRIPTION	SKETCH	QTY
1	BOLT M8 x 1 6/10"		3 PCS	10	SPANNER 10 MM ( M6 )		1 PC
2	BOLT M6 x 6/10"		4 PCS	11	FLAT WASHER M6 x 7/9"		4 PCS
3	WOOD DOWEL Ø8 x 1 1/5"		2 PCS	12	SPRING WASHER M6 x 7/15"		4 PCS
4	CSK SCREW M4 x 1"		8 PCS	13	SUPPORT LEG ADJUSTABLE FEET		3 PCS
5	STUD BOLT M6 x 2 3/8"		20 PCS				
6	HEX NUT M6		20 PCS				
7	BEND WASHER Ø7.5		20 PCS				
8	BEND WASHER 3013		20 PCS				
9	M4 ALLEN KEY		1 PC				

WEIGHT CAPACITY	600 LBS
-----------------	---------

HARDWARE DIMENSIONS  
VERIFICATION TOOL

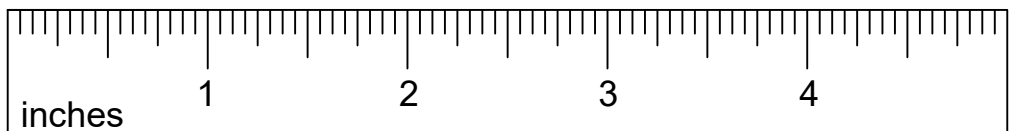

# ASSEMBLY INSTRUCTIONS

MODEL:

B1862-312 - ROWLAND 5/0 QUEEN SOLID WOOD  
ARCHED HEADBOARD-WALNUT

B1862-330 - PLATFORM BEDS

**STEP 1: INSERT WOODEN (3) TO (B)&(C) THEN INSERT ALL (5) TO (B),(C),(D),(E)**

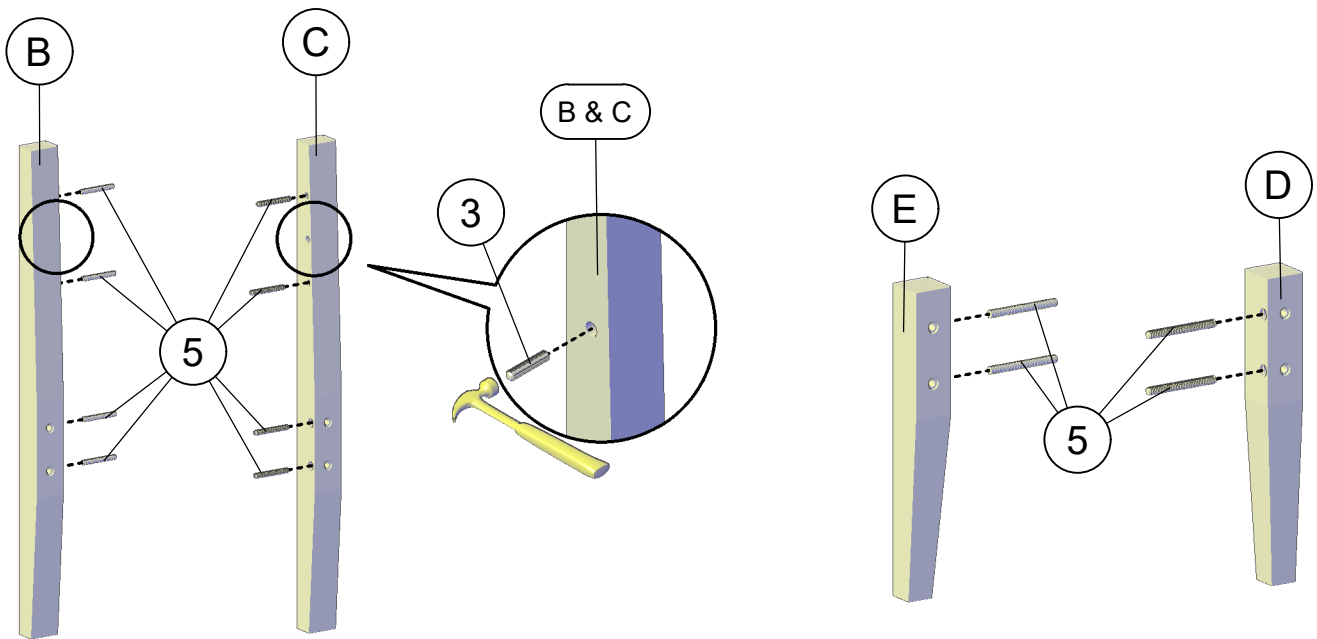

**STEP 2: FIRST.FLIP THE ENTIRE HB ASSEMBLY TO THE BACK SIDE, AND TIGHTEN PART 6 FROM SECTION A. THEN, ATTACH PARTS 6,7 AND 8 FROM SECTION F ONTO PART 5. USE PART 10 TO TIGHTEN PART 6. ONCE THAT'S DONE,**

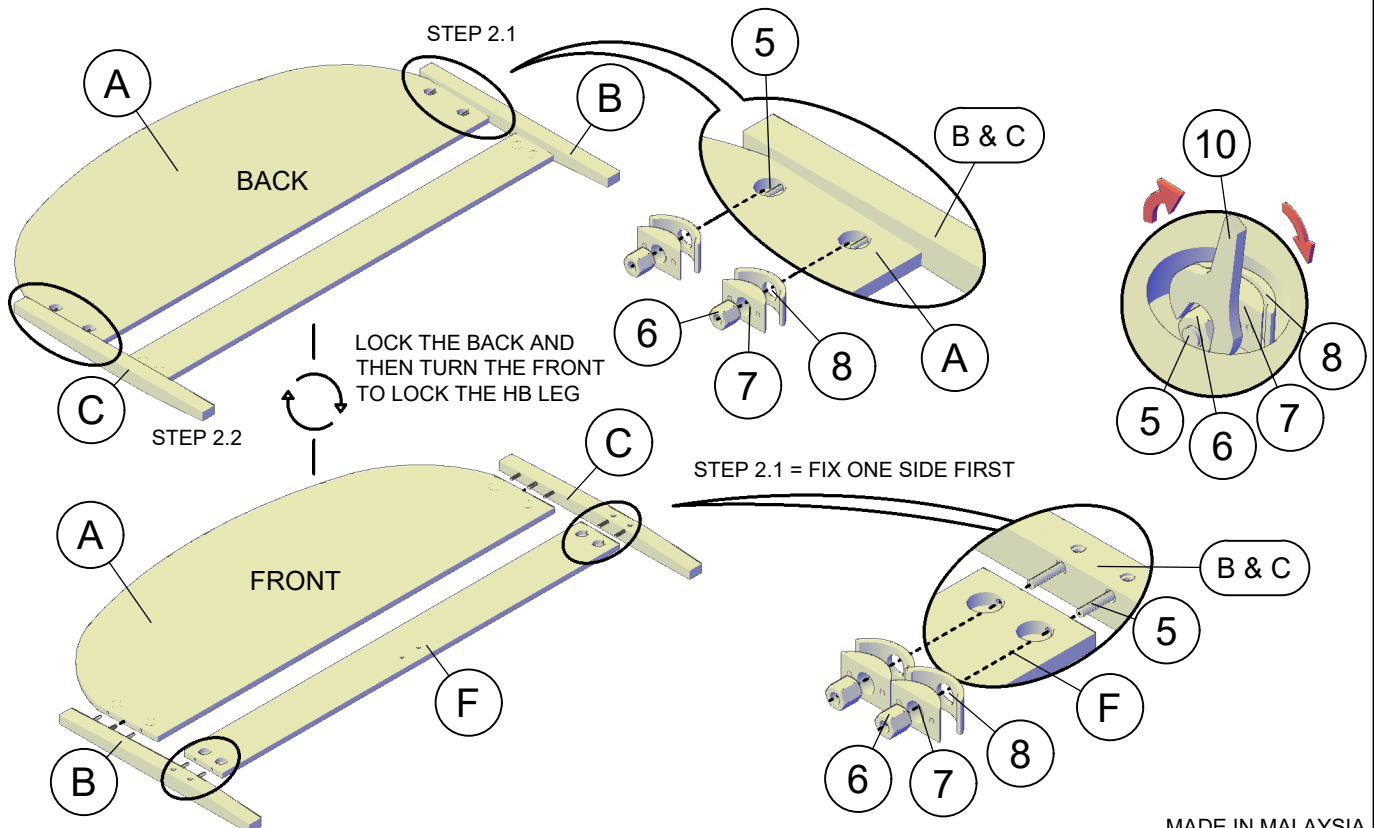

# ASSEMBLY INSTRUCTIONS

MODEL:

B1862-312 - ROWLAND 5/0 QUEEN SOLID WOOD  
ARCHED HEADBOARD-WALNUT

B1862-330 - PLATFORM BEDS

**STEP 3: ALIGN D & E TO F THEN USE 10 TIGHTEN 6**

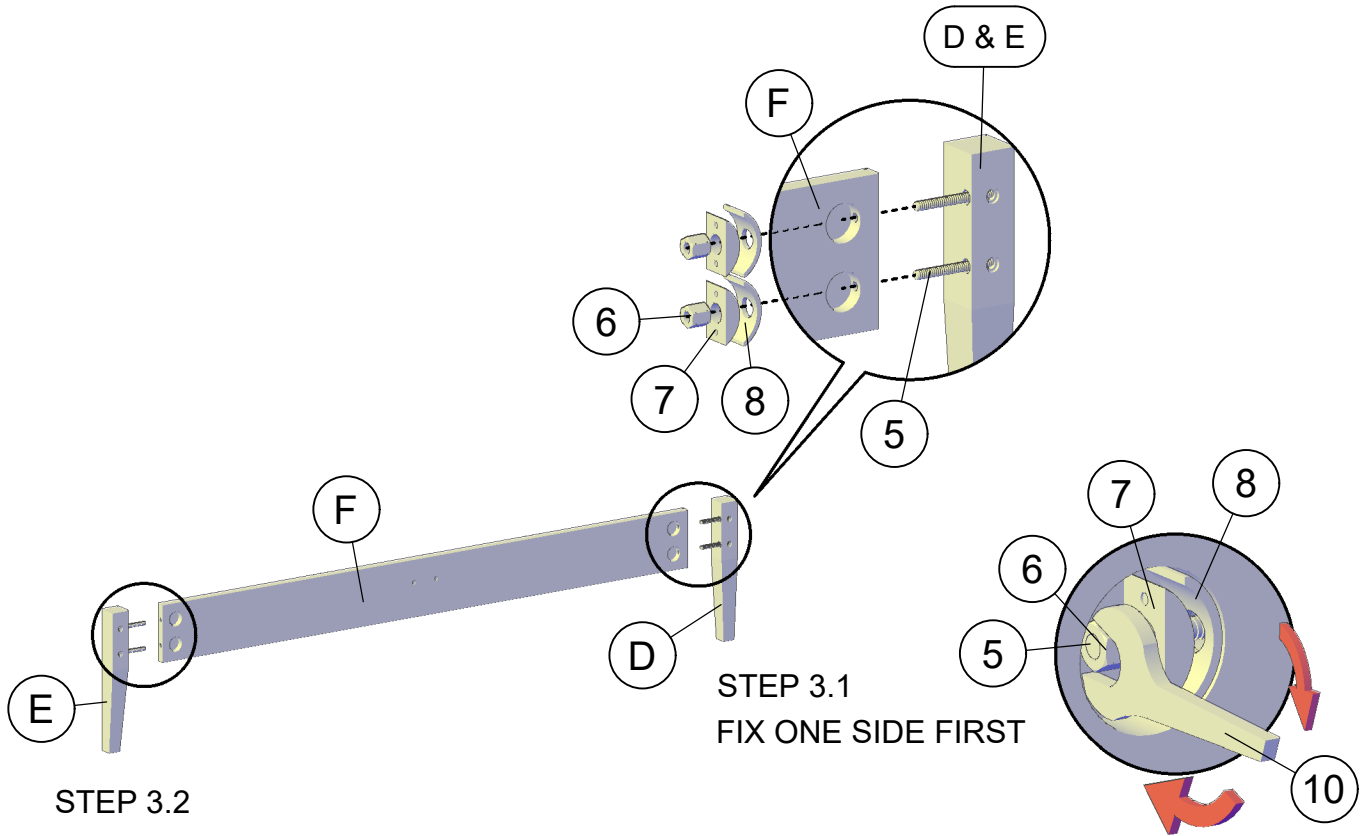

**STEP 4: INSERT 5 TO B & C**

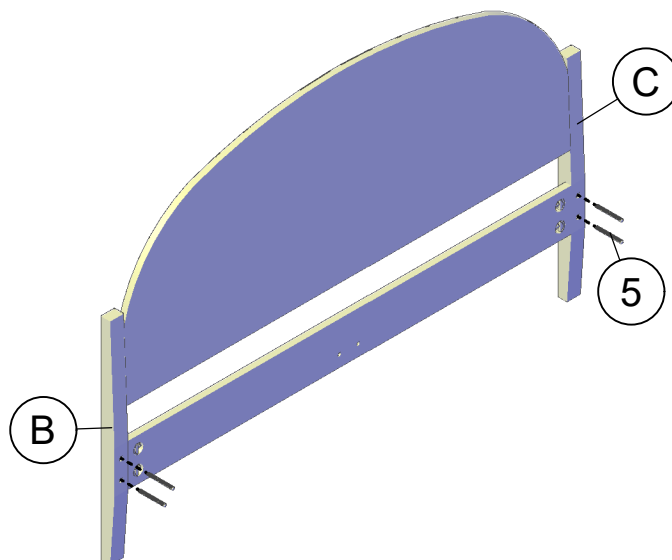

# ASSEMBLY INSTRUCTIONS

MODEL:

B1862-312 - ROWLAND 5/0 QUEEN SOLID WOOD  
ARCHED HEADBOARD-WALNUT

B1862-330 - PLATFORM BEDS

**STEP 5: INSERT 5 TO E AND D**

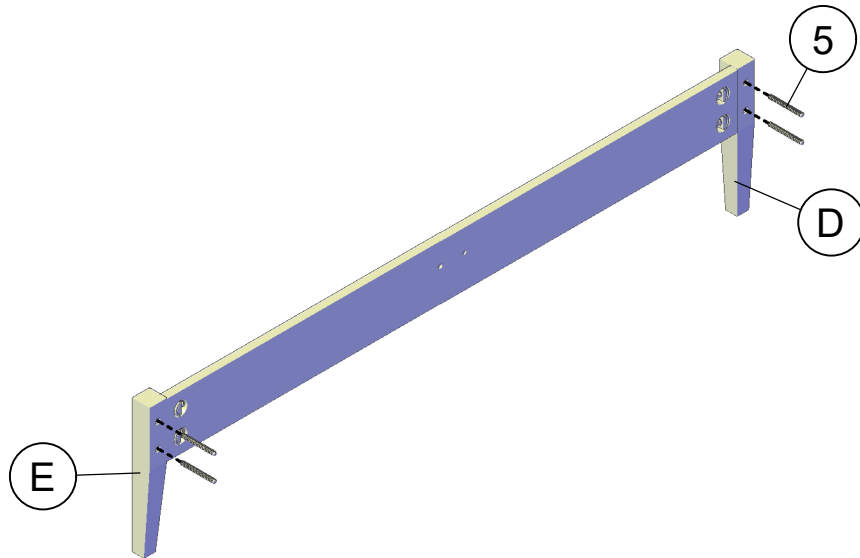

**STEP 6: INSERT G TO B-E THEN USING 10 TO TIGHTEN 6**

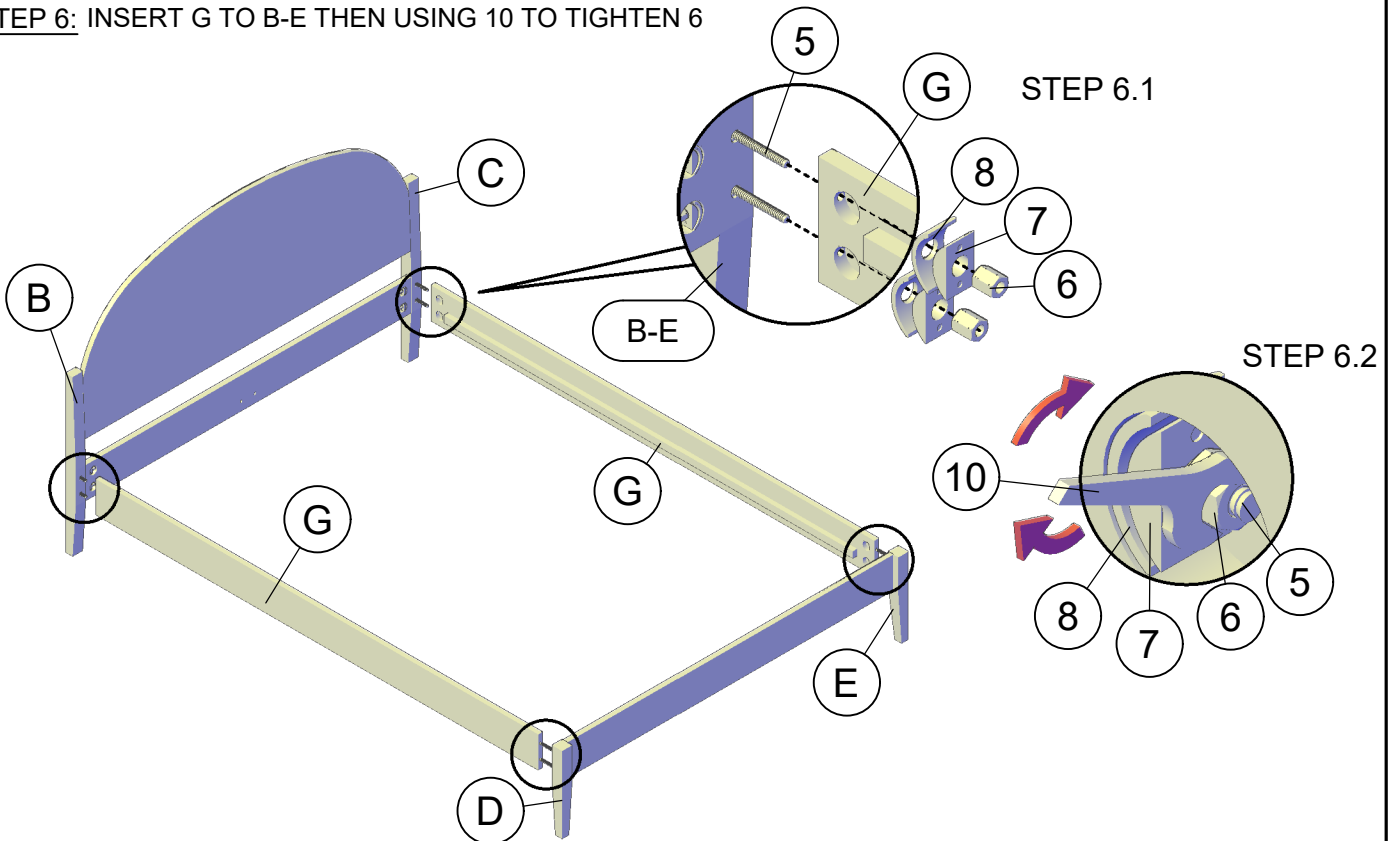

# ASSEMBLY INSTRUCTIONS

MODEL:

B1862-312 - ROWLAND 5/0 QUEEN SOLID WOOD  
ARCHED HEADBOARD-WALNUT

B1862-330 - PLATFORM BEDS

**STEP 7:** ALIGN THE I WITH H, THEN USE TIGHTEN 1 USING 9

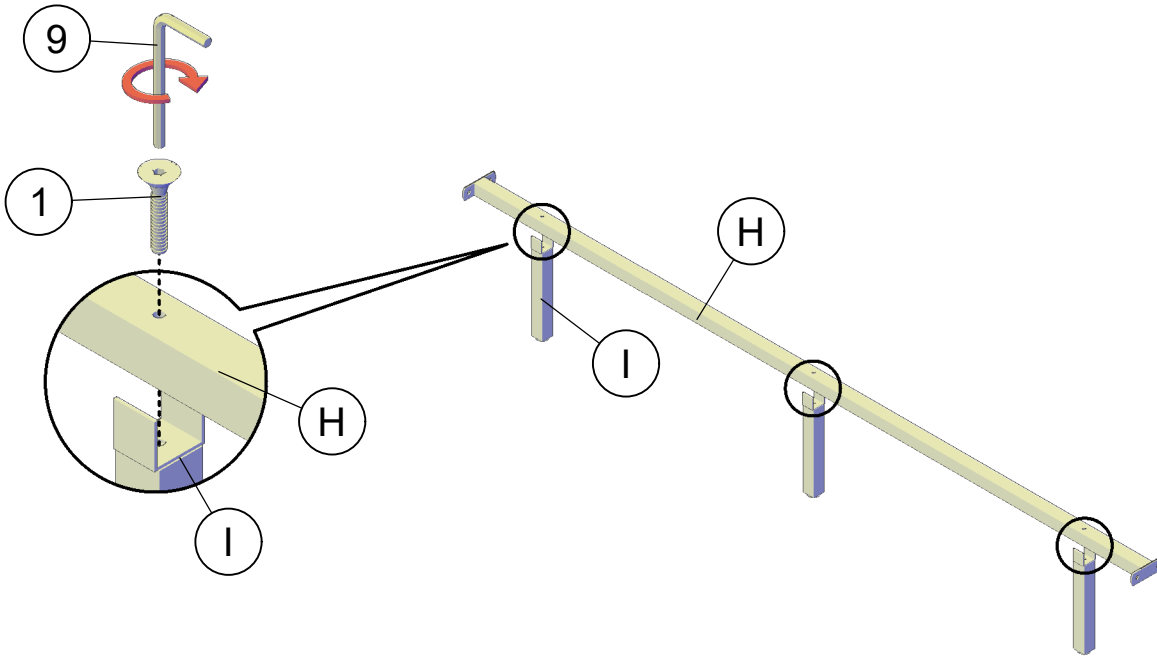

**STEP 8:** ALIGN THE H IN THE HOLE OF F, THEN USE IT TO INSTALL PARTS 11 AND 12 ONTO PART 2. AFTER THAT, TIGHTEN PART 2 USING PART 9.

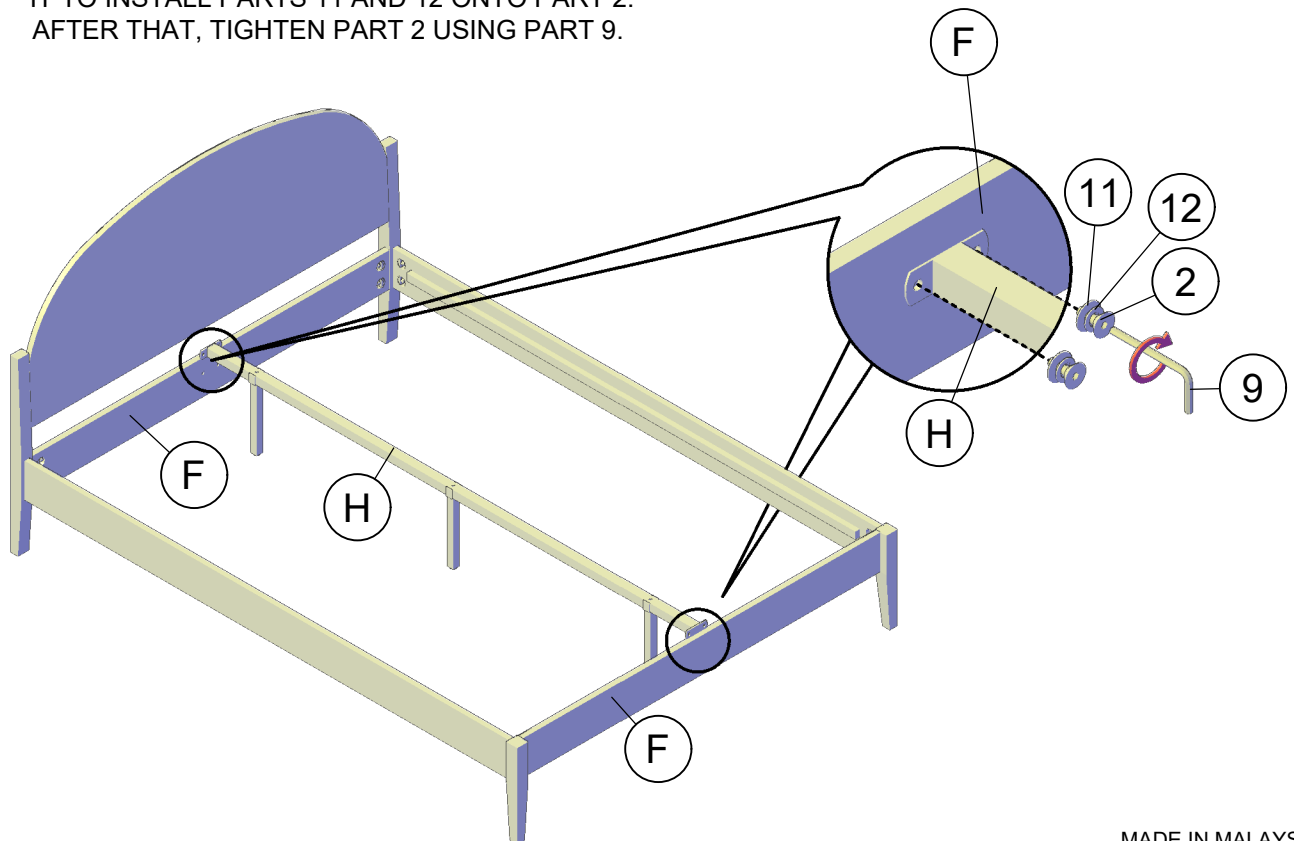

# ASSEMBLY INSTRUCTIONS

MODEL:

B1862-312 - ROWLAND 5/0 QUEEN SOLID WOOD  
ARCHED HEADBOARD-WALNUT

B1862-330 - PLATFORM BEDS

STEP 9: PLACE J DOWN, THEN USE A SCREWDRIVER TO TIGHTEN 4.

ASSEMBLY COMPLETE

