

Assembly Instructions

1. Remove all parts from the carton A&B and place them on a protected surface or carpet. Take out the legs 4 (plastic legs-4pcs, wood legs-4pcs) out of the A box.

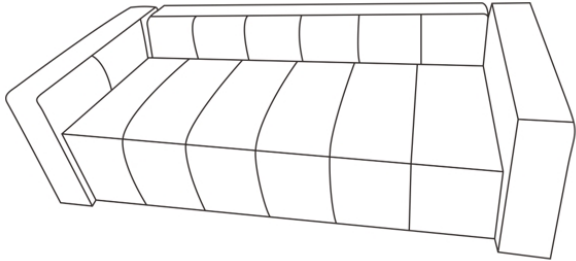

| No. | Parts | Quantity |
|--------|-------|----------|
| 1-BACK | | 1 |
| 2-ARMS | | 2 |
| 3-SEAT | | 1 |
| 4-LEGS | | 8 |

2. Attach the black plastic legs (4) to the bottom corners of the seat cushion (3) as shown. Attach the wood legs (4) to the bottom corners of the arms.

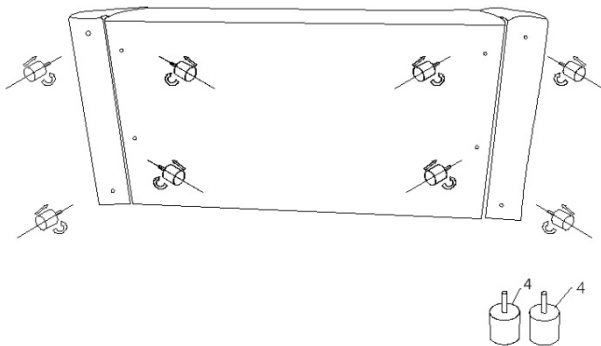

3. Make sure the male and female brackets align then attach the right side facing arm (2) to right side of the seat cushion (3) as shown.

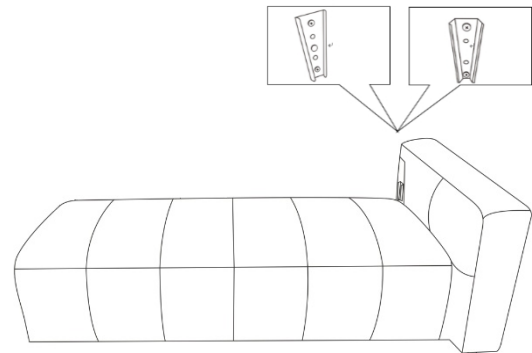

4. Make sure the male and female brackets align then attach the left side facing arm (2) to left side of the seat cushion (3) as shown.

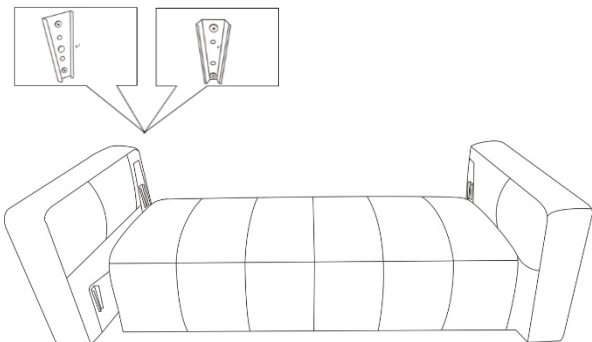

5. Make sure the male and female brackets align then attach the back cushion (1) to rear side the seat cushion (3) as shown.

