

# Shoes Bench

ASSEMBLY INSTRUCTIONS

---

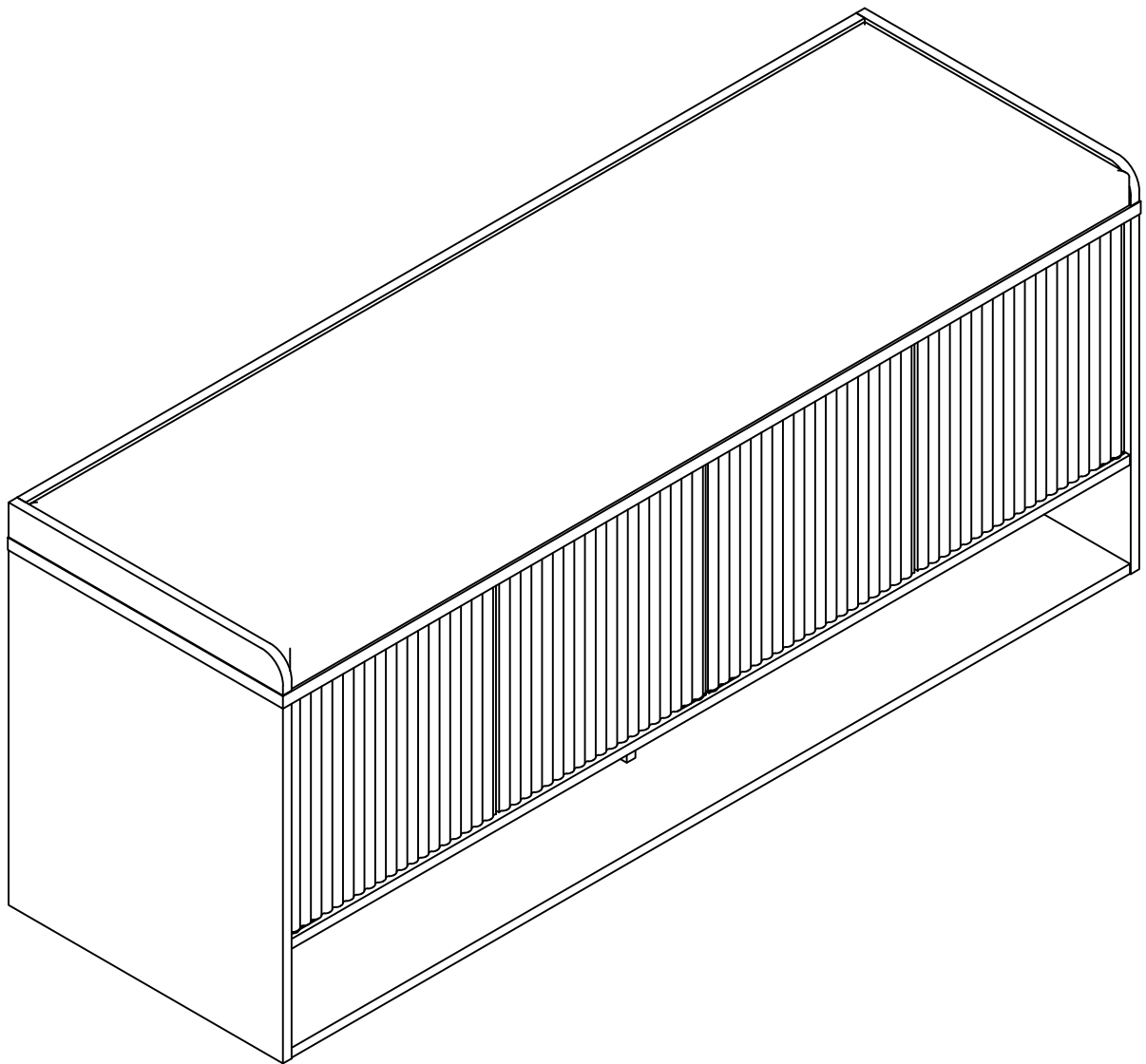

## General Guidelines

- \* Please read the following instruction carefully and use the product accordingly.
- \* Please keep this manual and hand it over when you transfer the product.
- \* This summary may not include every detail of all variations and considered steps. Please contact us when further information and help are needed.

## Notes

- \* The product is intended for indoor use only. The product must be assembled and used in accordance with the provisions of the manual. Personal injury and/or damage to product may occur if products are used outside of their intended purposes and/or if products have been changed/modified from their original design. The seller does not assume any responsibility or liability with respect to any injury/damage caused by incorrect assembly or improper use.
- \* If there are any defective or missing parts after unpacking, please cease assembly immediately and contact us.
- \* Please wear gloves during the assembly and/or disassembly process to avoid scratches from any sharp edges..
- \* Please place this item on level, solid ground during use.
- \* Avoid long-term exposure to humid environments to prevent mildew.
- \* Keep the product away from fire sources and high temperatures. Do not expose the product to direct sunlight.
- \* Do not place any hot objects on the surface of the product.
- \* **Do not fully tighten the screws during initial assembly. Fully tighten screws only once all pieces which are correctly assembled**

## Warnings

- \* Children are not allowed to assemble the product. During assembly, keep all any small parts out of the reach of children as they may be fatal if swallowed or inhaled.
- \* Children are forbidden to climb or play on the product to avoid serious bodily injury caused by the toppling.
- \* Keep plastic packing bags out of reach of children to avoid any potential danger, such as suffocation.



# ASSEMBLY TOOLS REQUIRED (NOT INCLUDED)

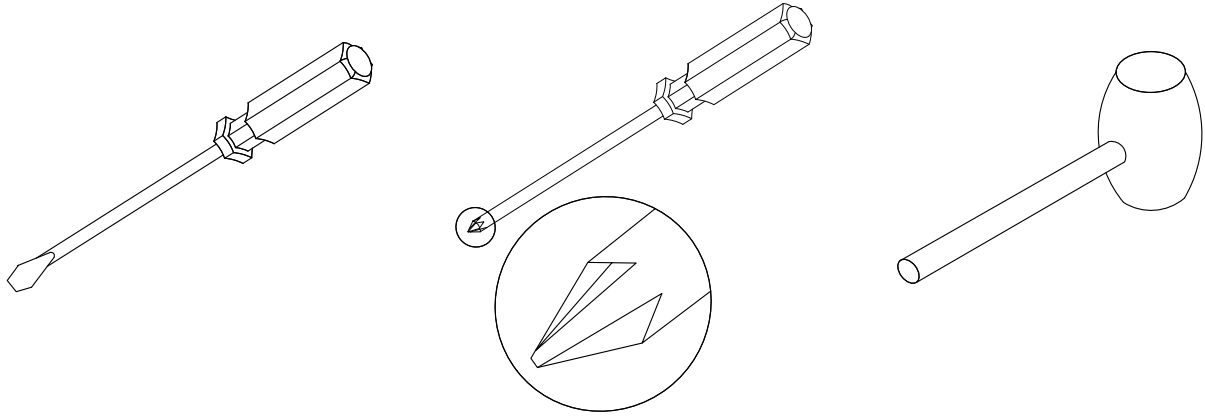

Bolt



Connecting piece

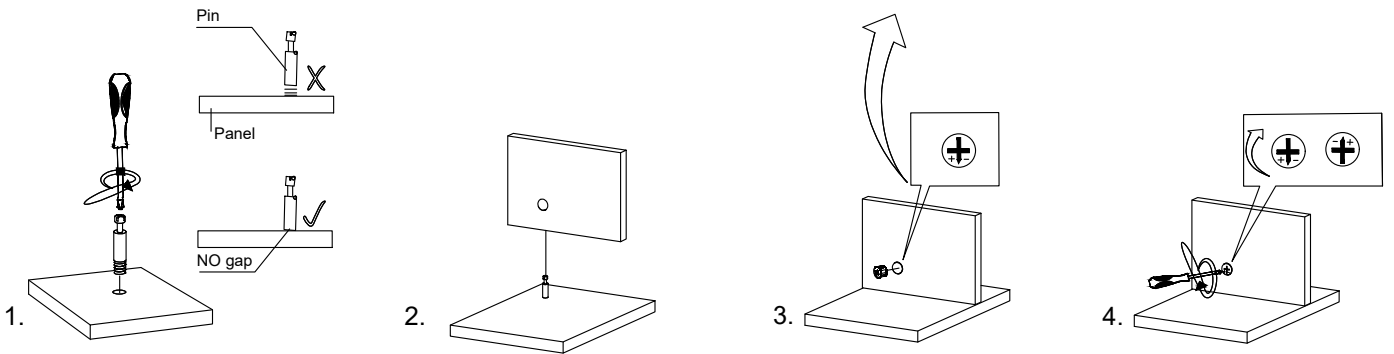
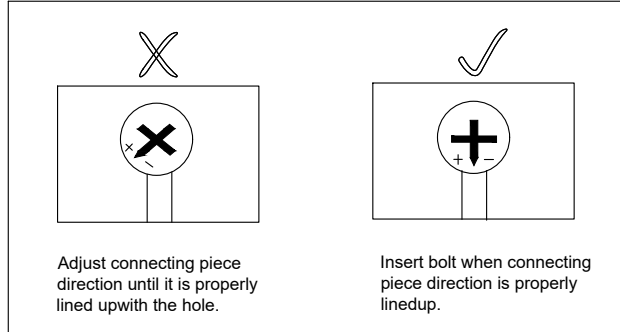

# Hardware Provided

A

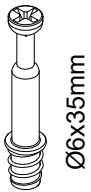

X 18+2

B



X 18+2

C



X 26+2

D



X 12+1

F

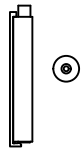

X 4

G



X 36+3

H

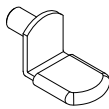

X 8+1

I

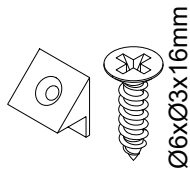

X 12+2

J

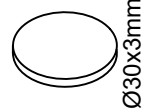

X 6+1

K



X 2

L

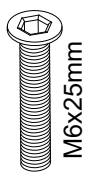

X 4+1

M



X 2+1

N



X 4+1

O

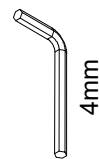

X 1

V

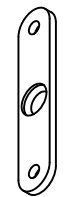

X 2

Y

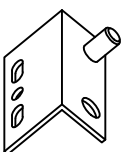

X 4

Z

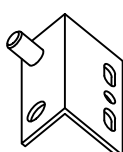

X 4



X 1

# Parts Identification

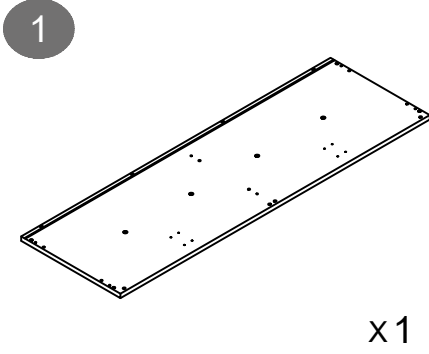
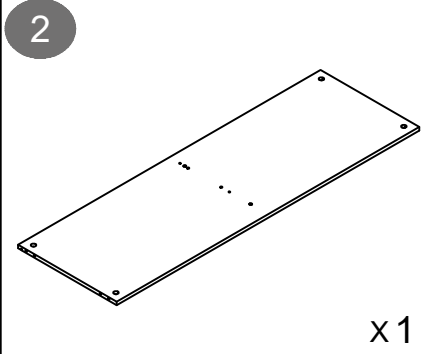
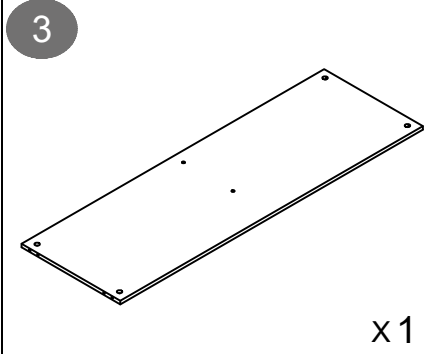
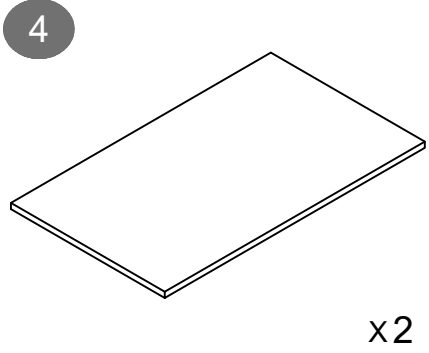
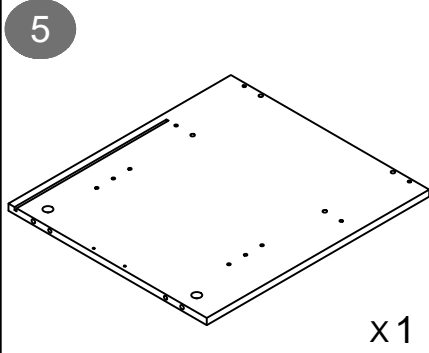
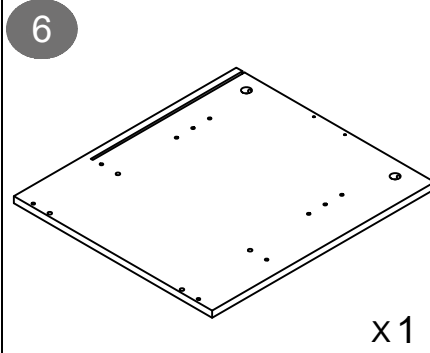
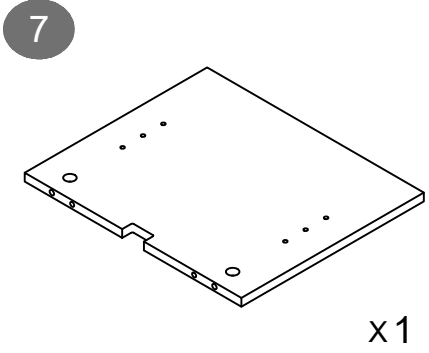
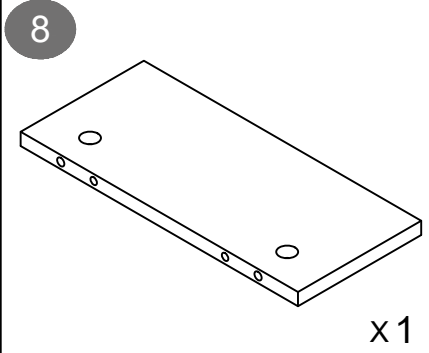
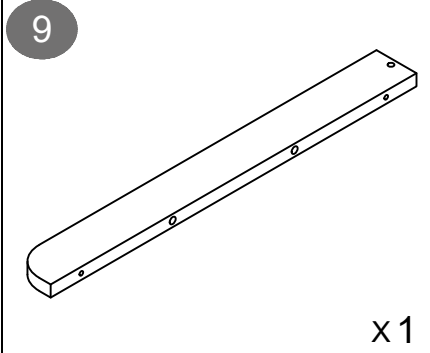
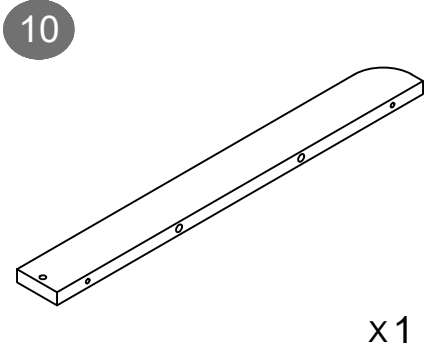
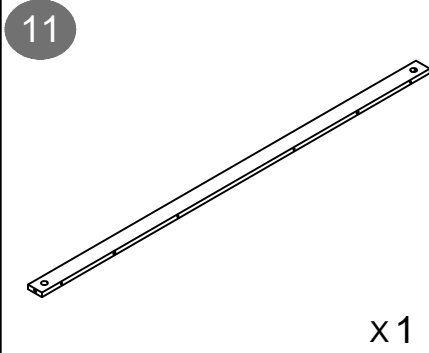
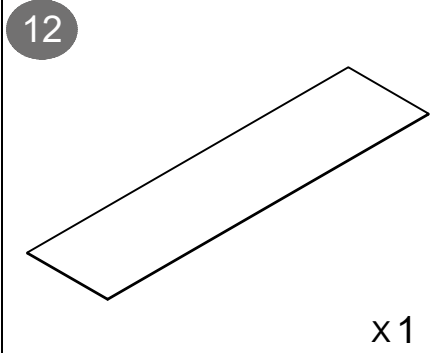
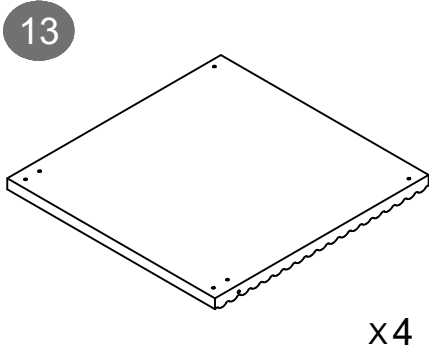
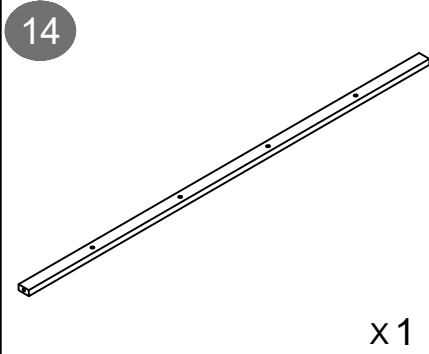
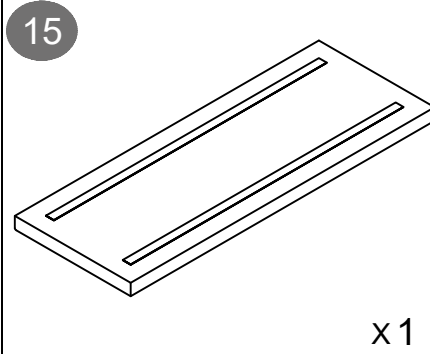
|   |  |   |
|---|--|---|
|  <p>1</p> <p>x1</p>    |  <p>2</p> <p>x1</p>    |  <p>3</p> <p>x1</p>    |
|  <p>4</p> <p>x2</p>    |  <p>5</p> <p>x1</p>    |  <p>6</p> <p>x1</p>    |
|  <p>7</p> <p>x1</p>   |  <p>8</p> <p>x1</p>   |  <p>9</p> <p>x1</p>   |
|  <p>10</p> <p>x1</p> |  <p>11</p> <p>x1</p> |  <p>12</p> <p>x1</p> |
|  <p>13</p> <p>x4</p> |  <p>14</p> <p>x1</p> |  <p>15</p> <p>x1</p> |

# Exploded View

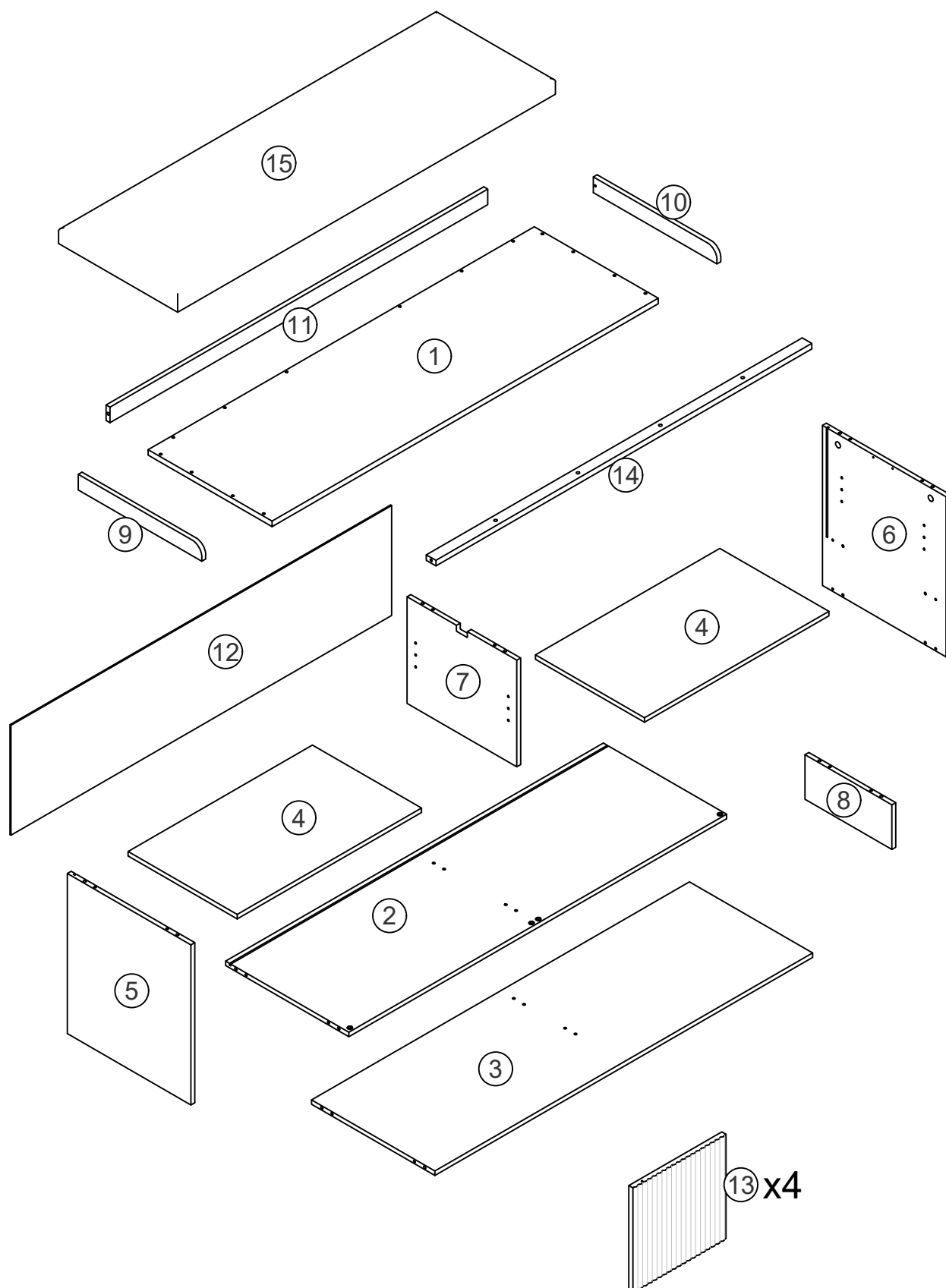

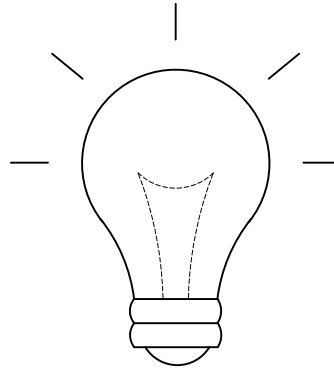

## friendly reminder

To avoid errors and confusion during the installation of accessories, use the type and quantity of hardware accessories according to the installation procedure described in the instructions. First, unroll the accessories bag and lay out the hardware accessories, cut holes in the side, and take out the hardware accessories

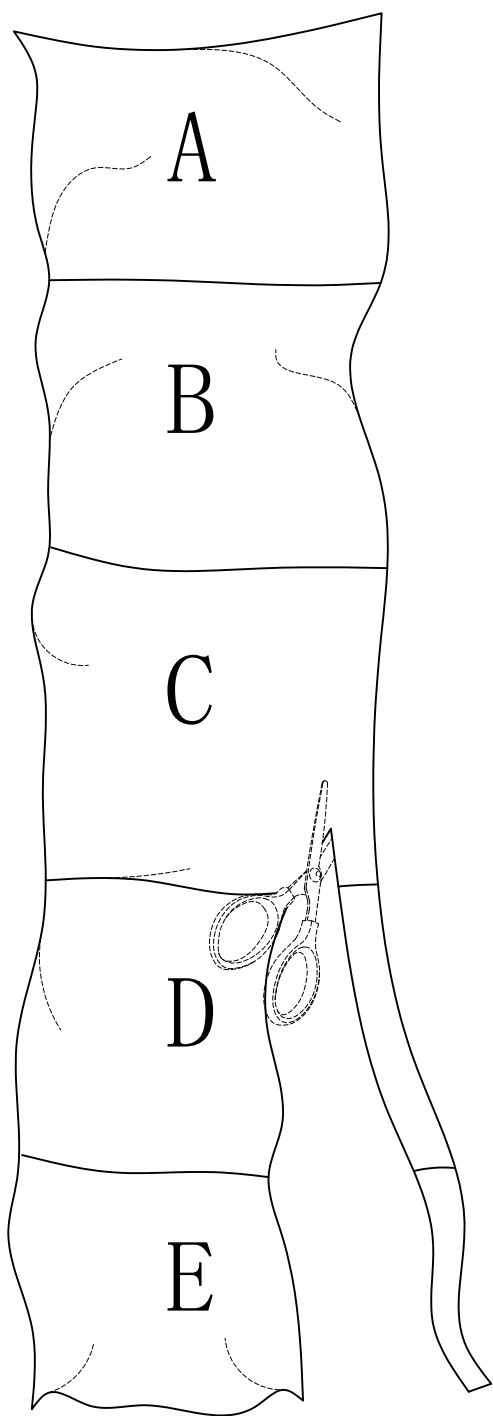

# STEP 01

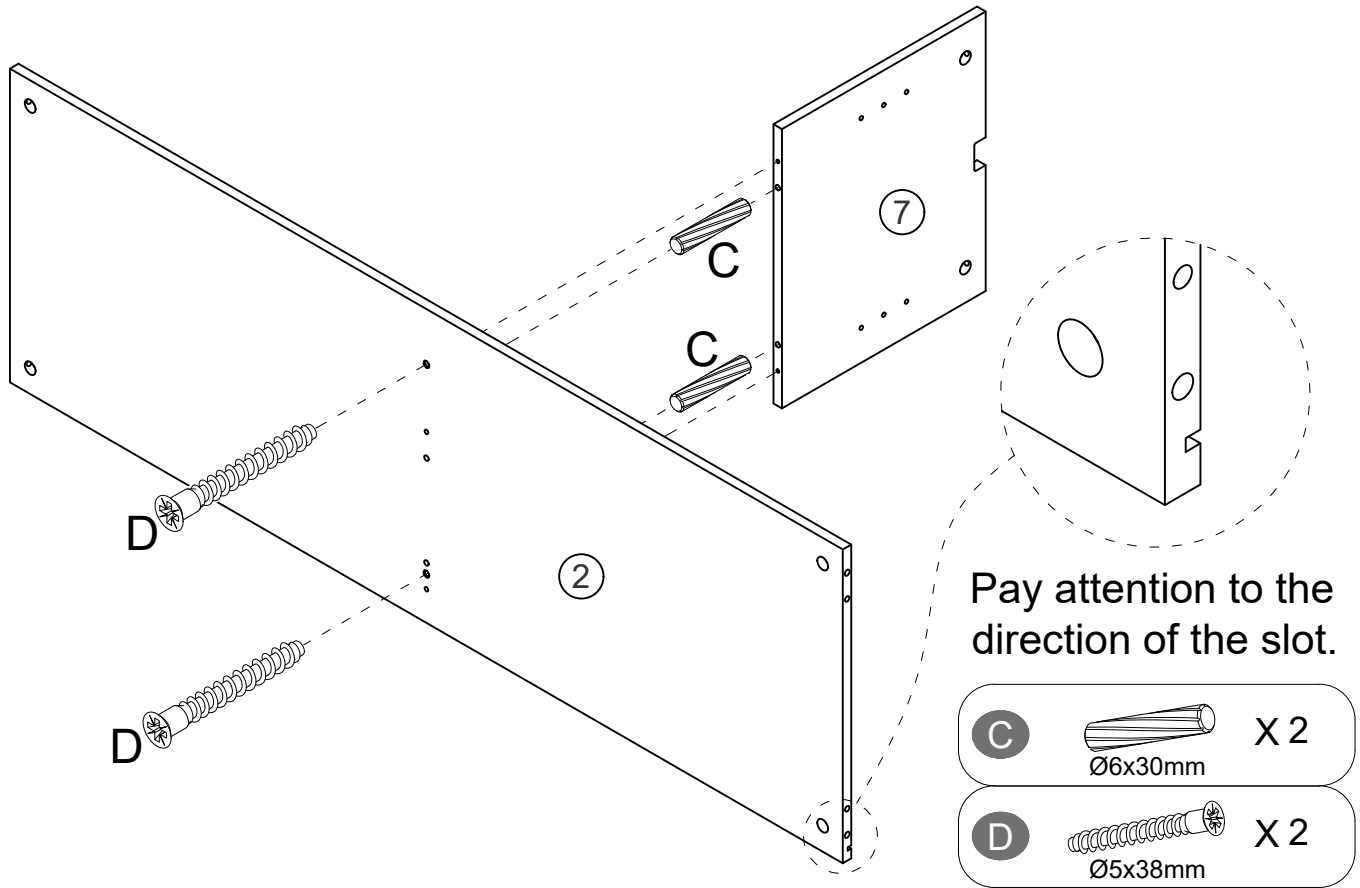

# STEP 02

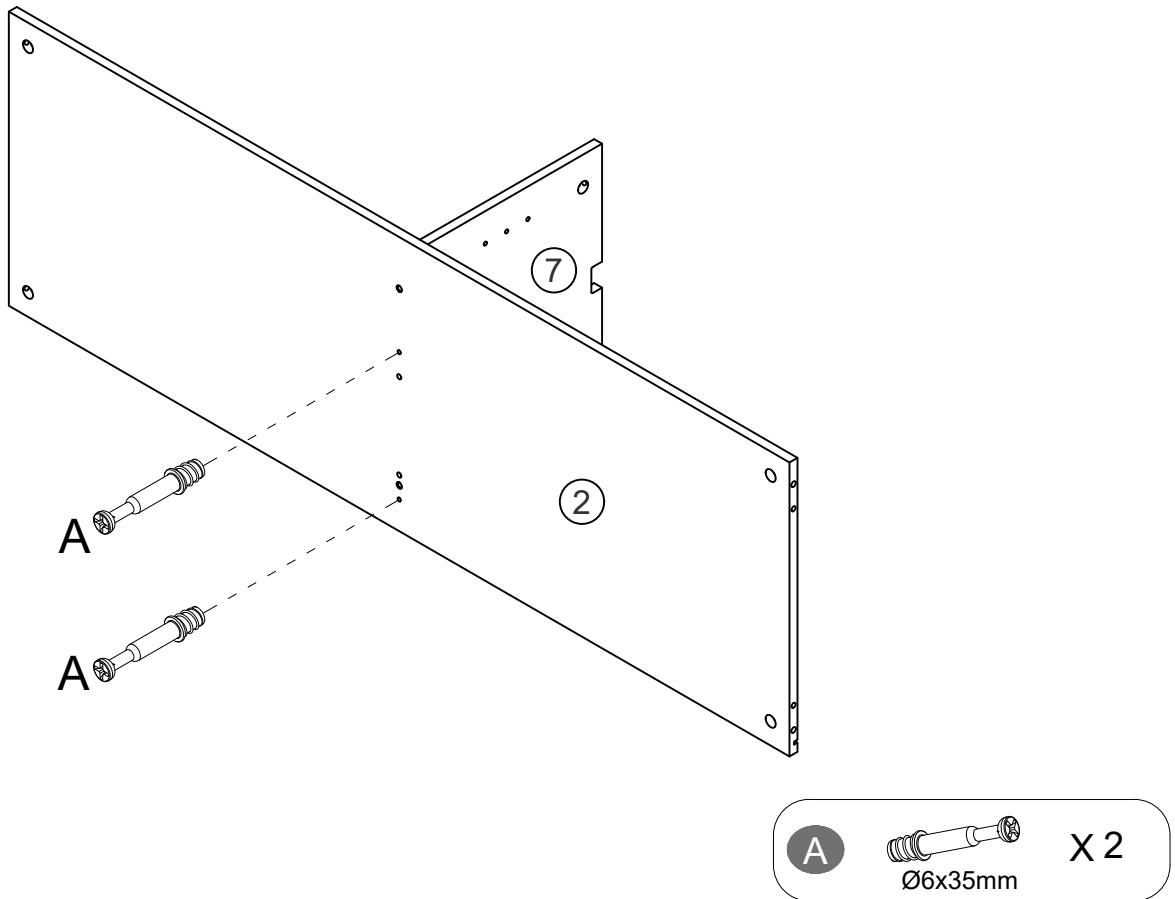

## STEP 03

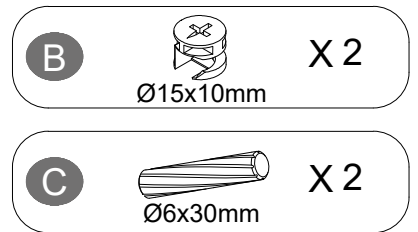
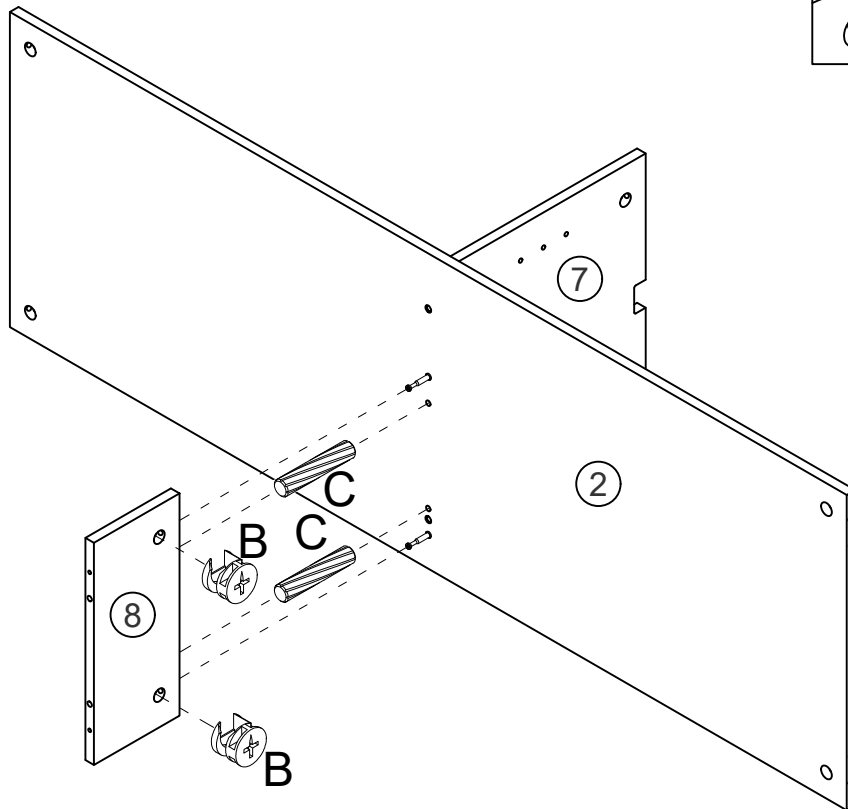
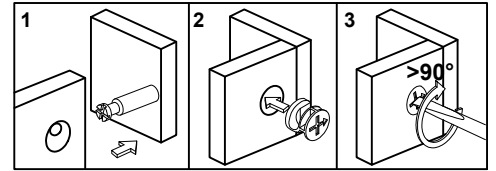

## STEP 04

Pay attention to the spacing between each hole and the edge, so as to distinguish the direction of component (3).

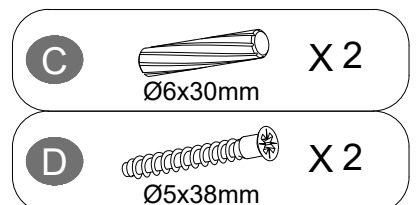
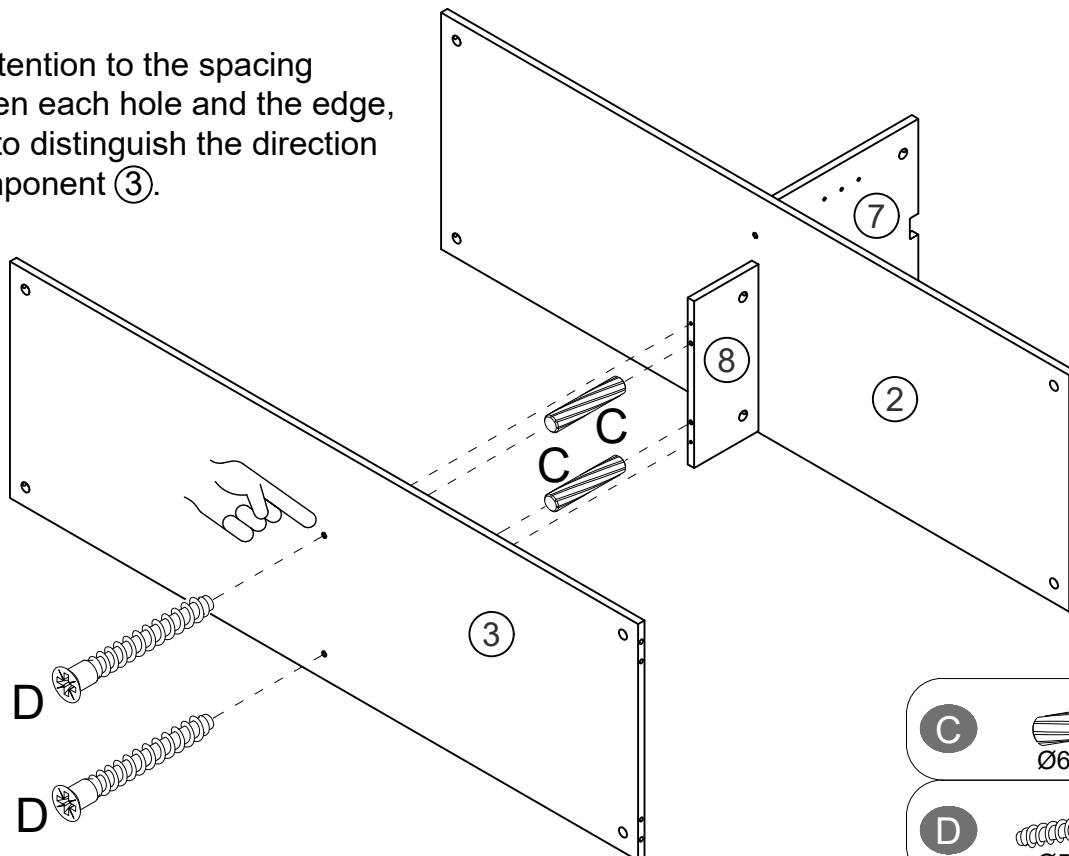

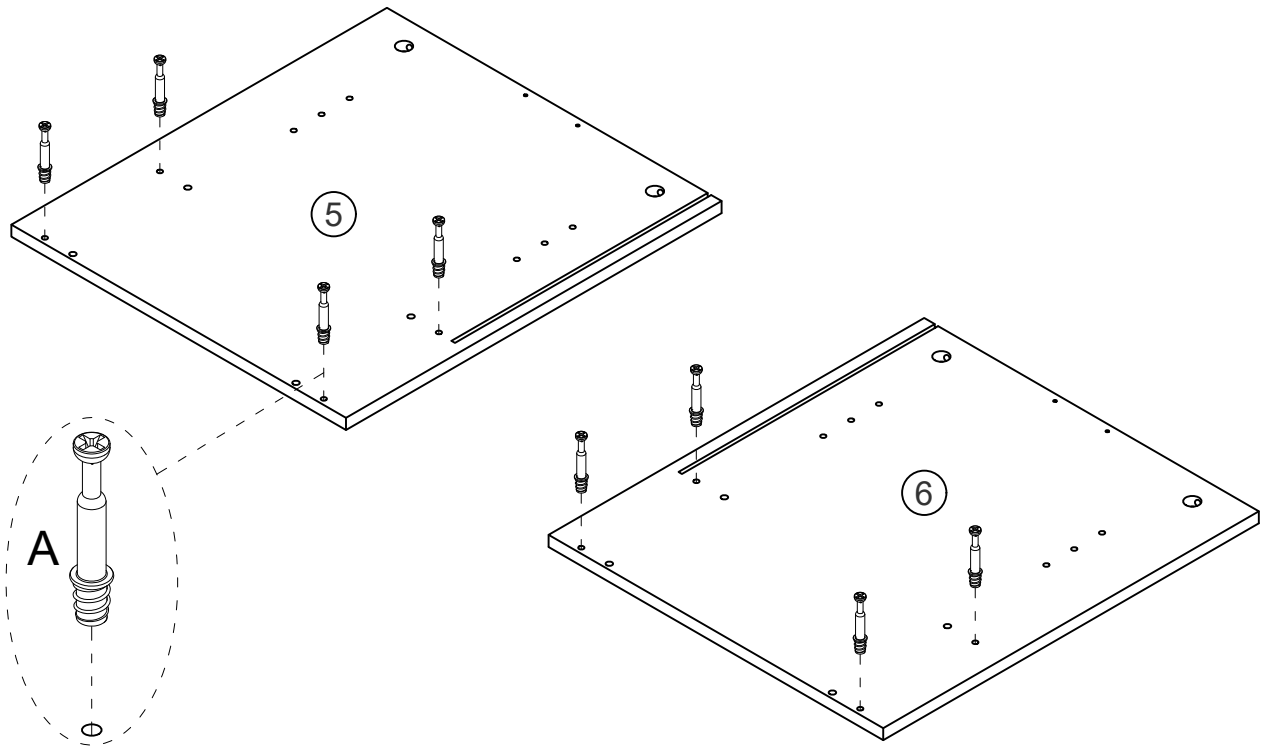

# STEP 05

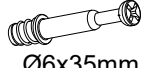

**A**  X 8  
Ø6x35mm

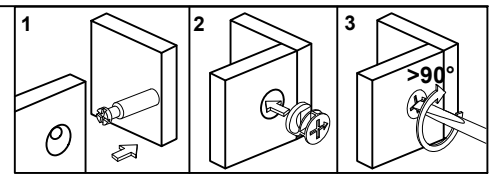
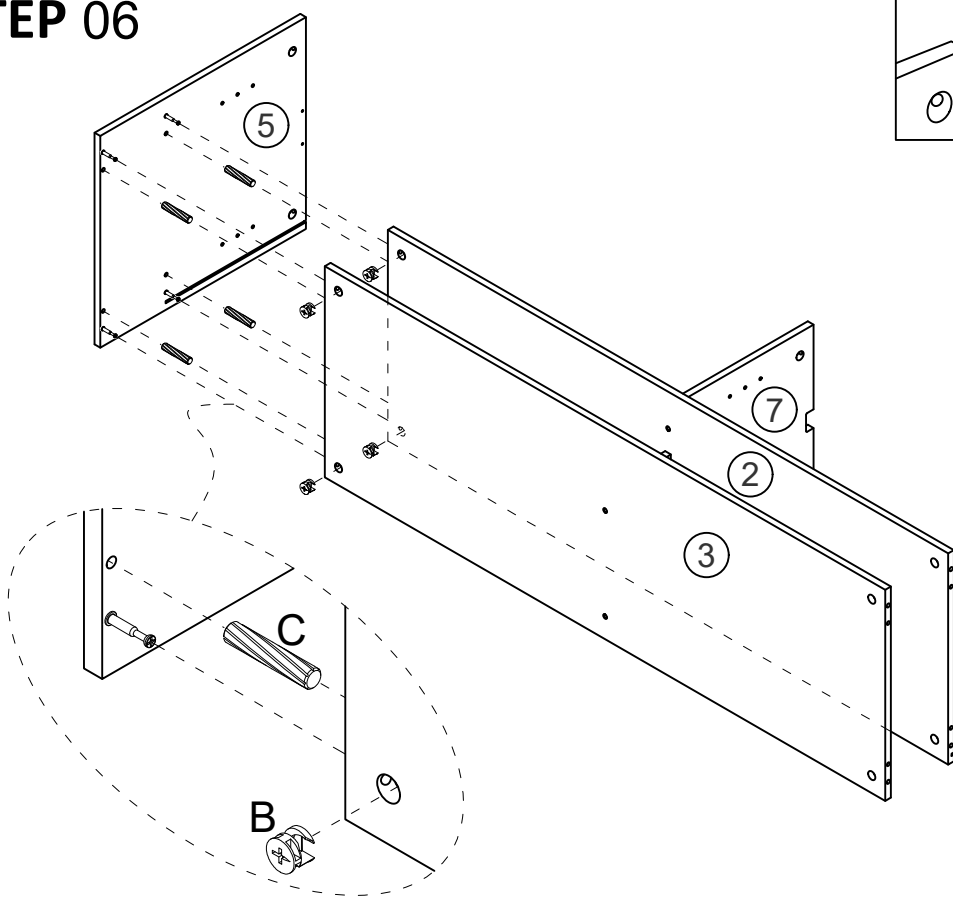
# STEP 06

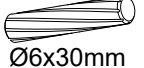

**B**  X 4  
Ø15x10mm

**C**  X 4  
Ø6x30mm

# STEP 07

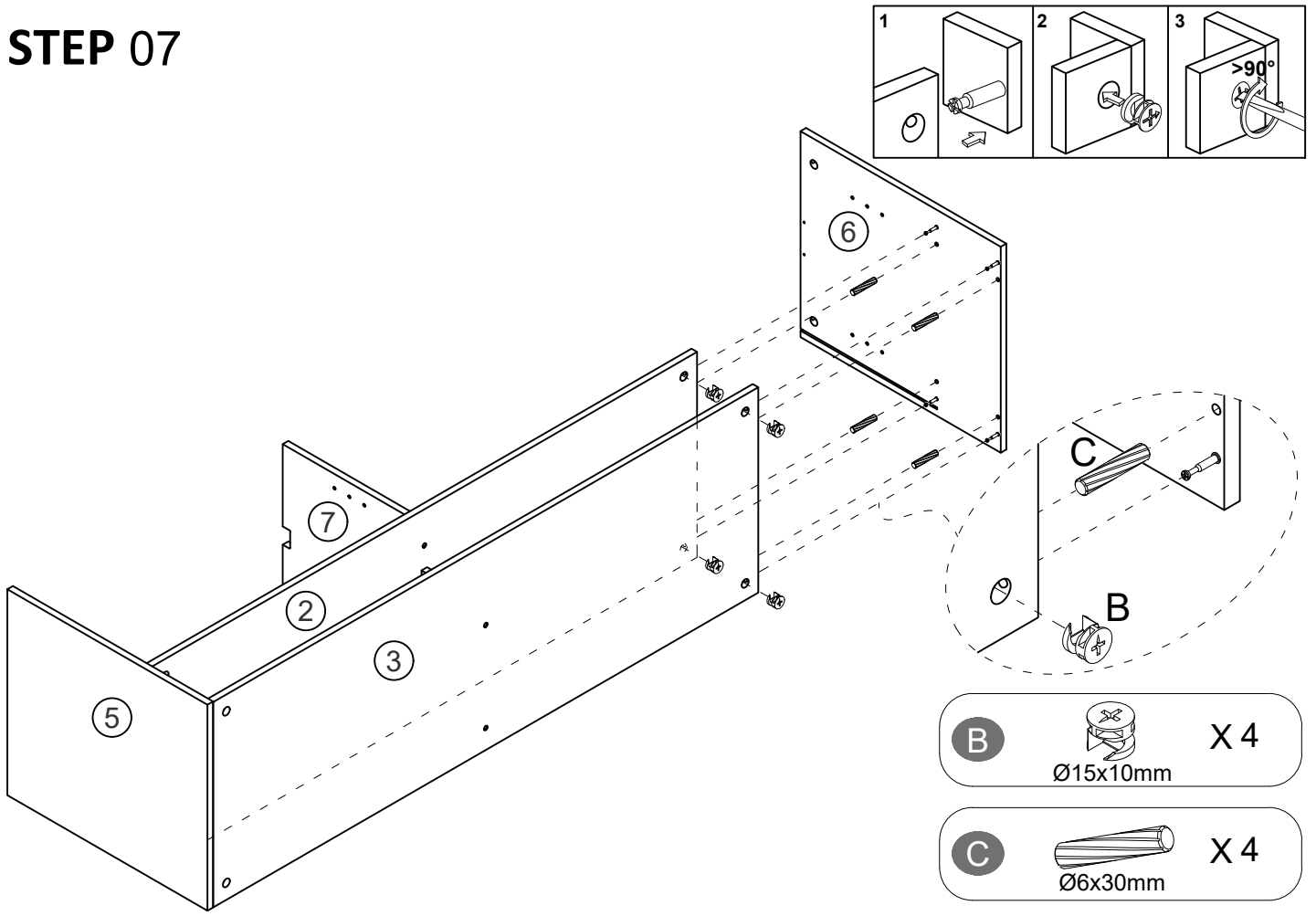

# STEP 08

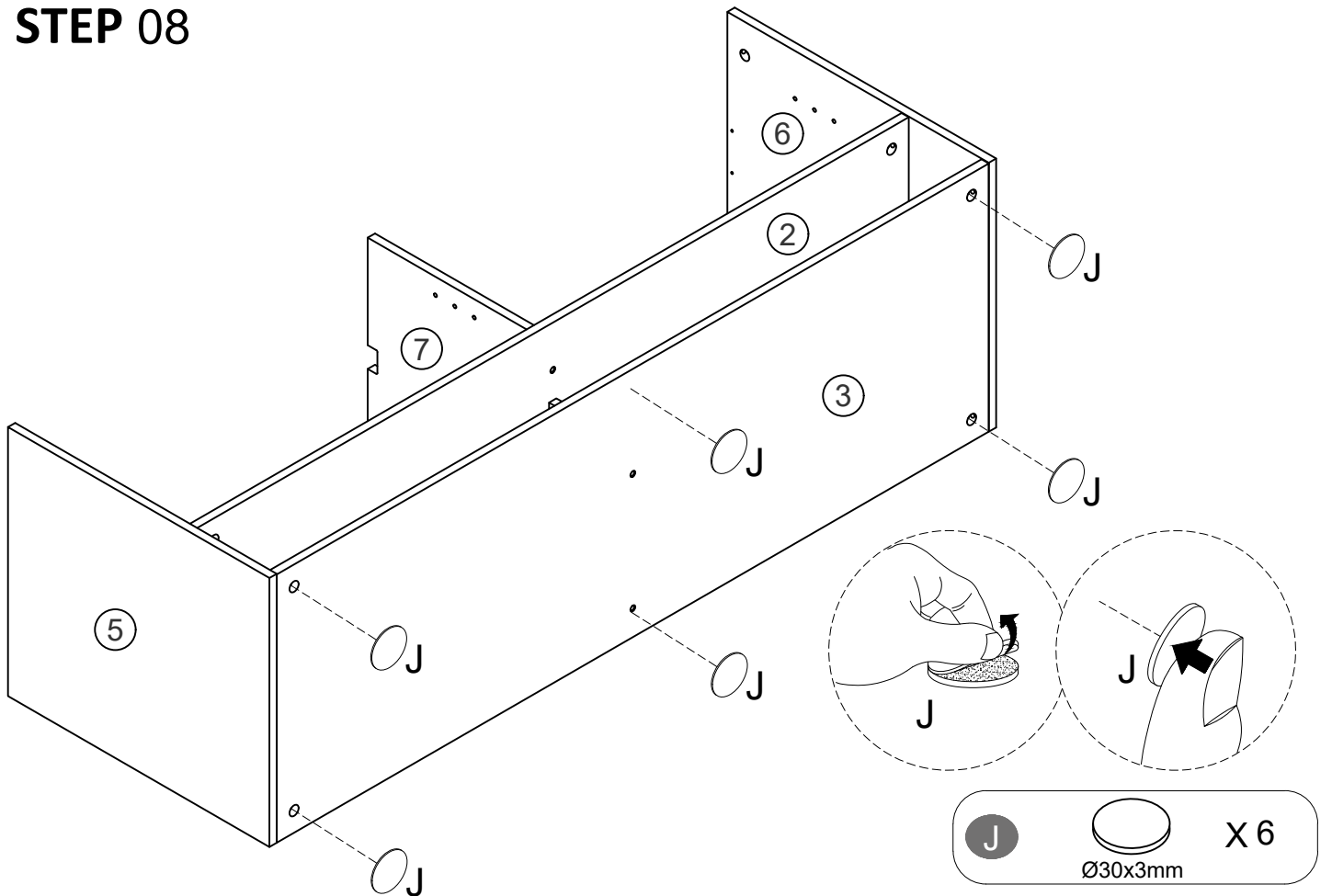

## STEP 09

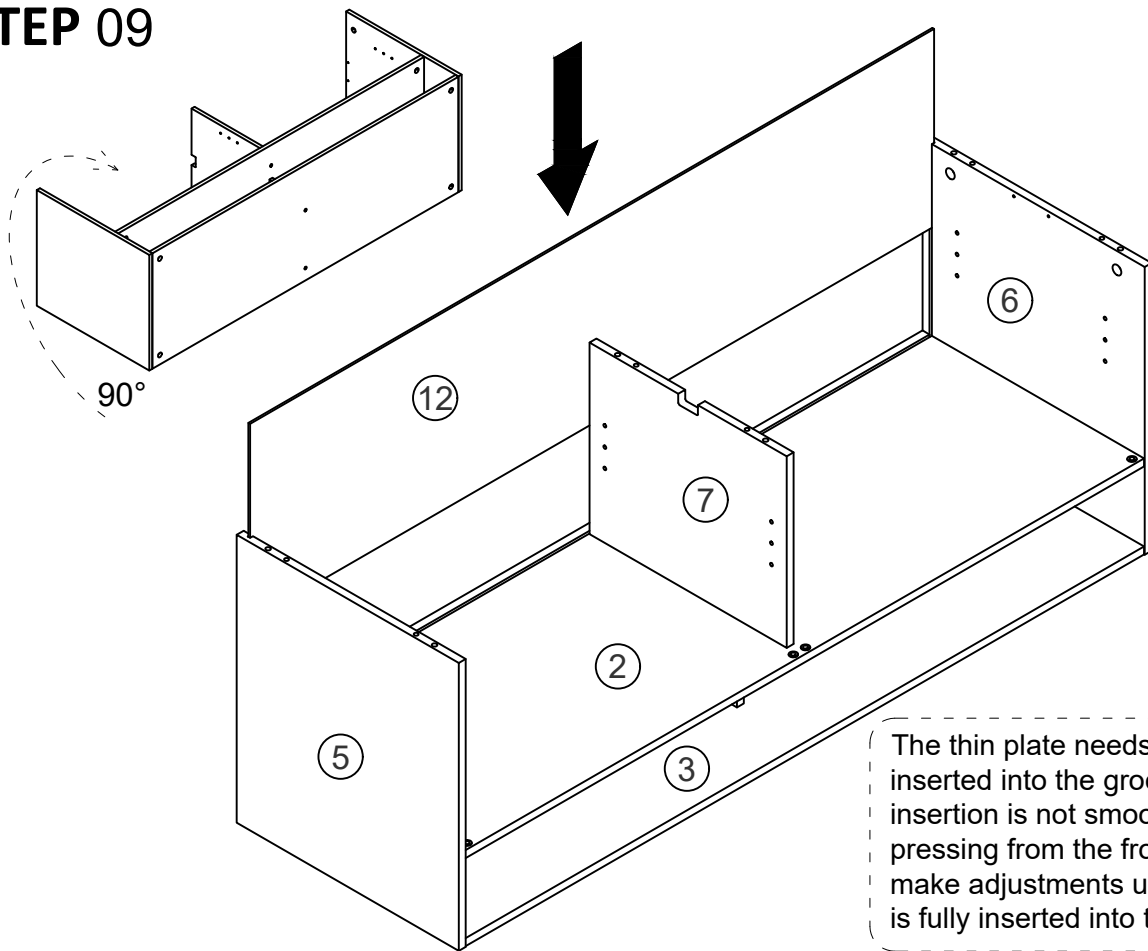

The thin plate needs to be fully inserted into the groove. If the insertion is not smooth, you can try pressing from the front or the back to make adjustments until the thin plate is fully inserted into the groove.

## STEP 10

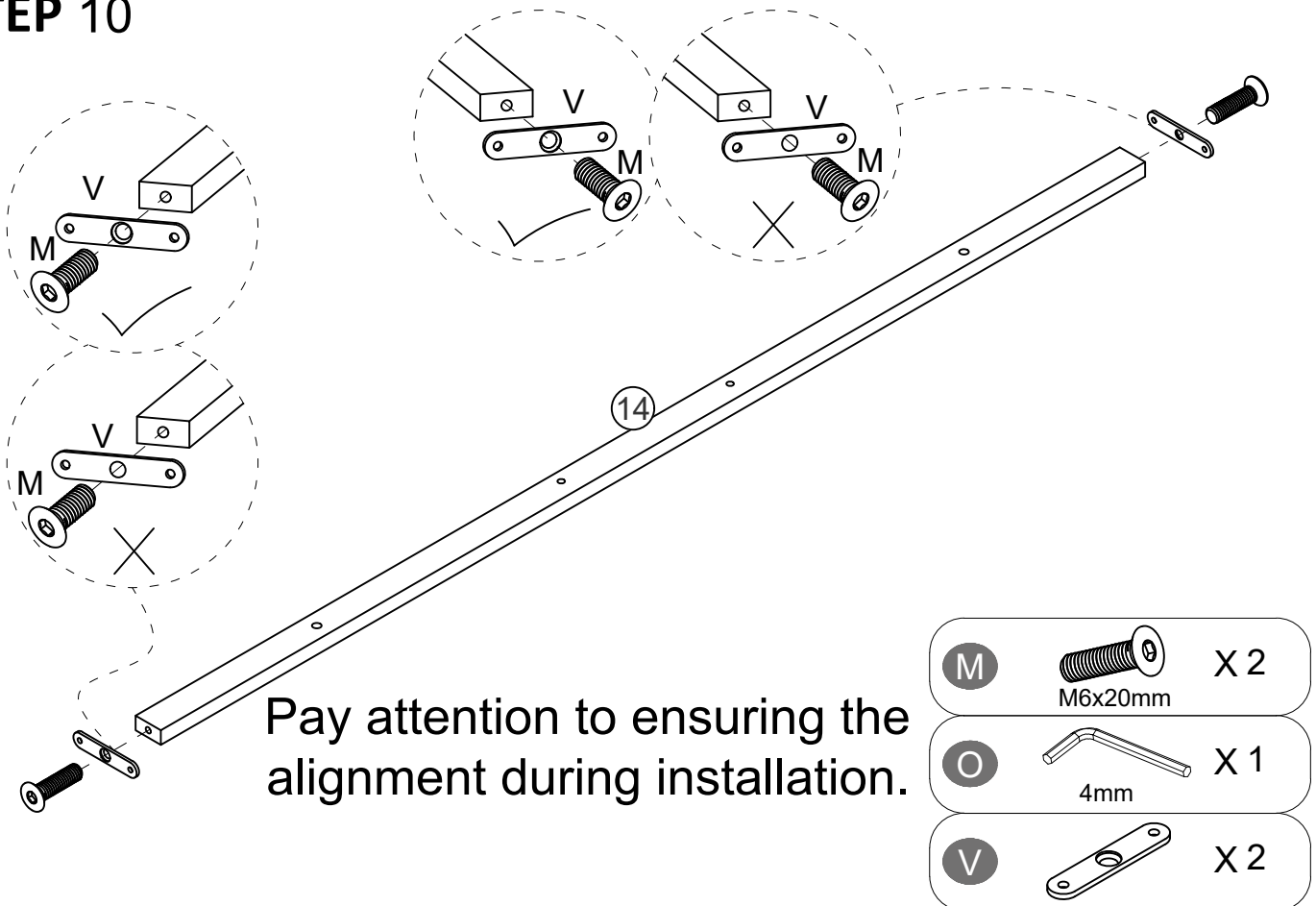

# STEP 11

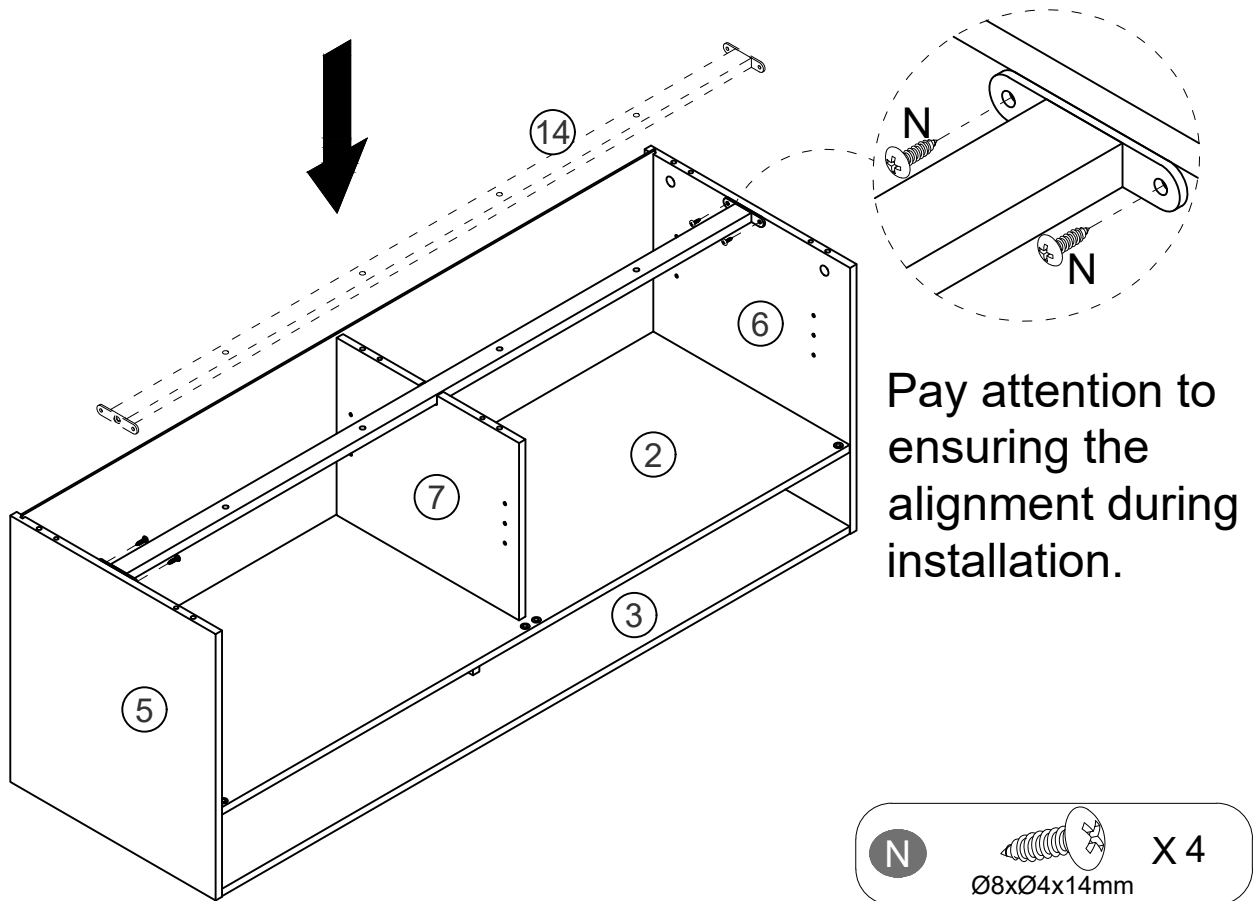

# STEP 12

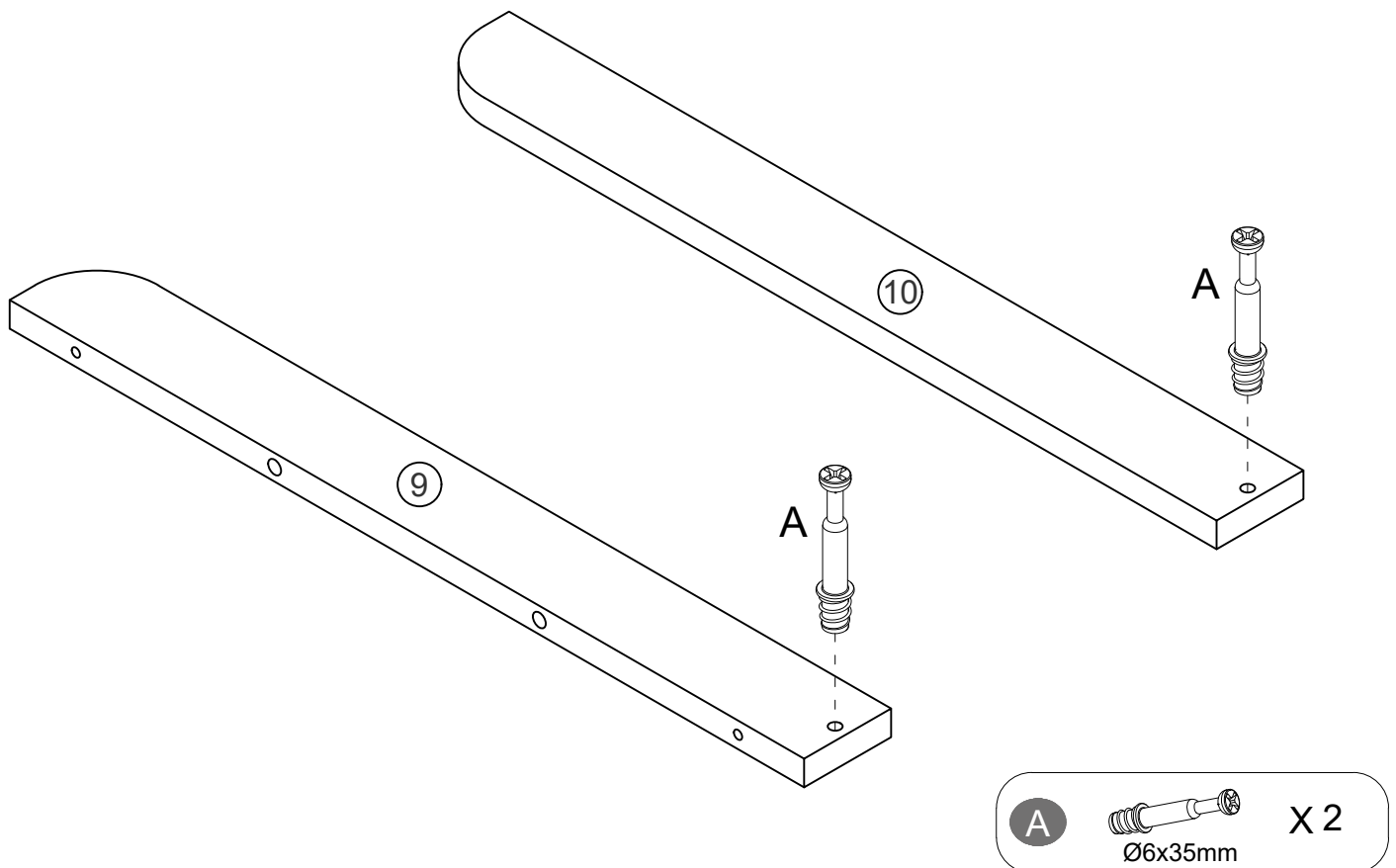

# STEP 13

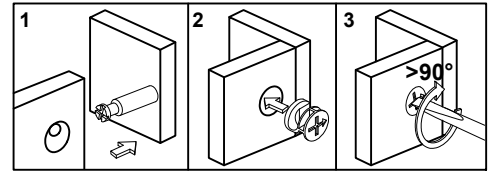

Pay attention to ensuring the alignment during installation.

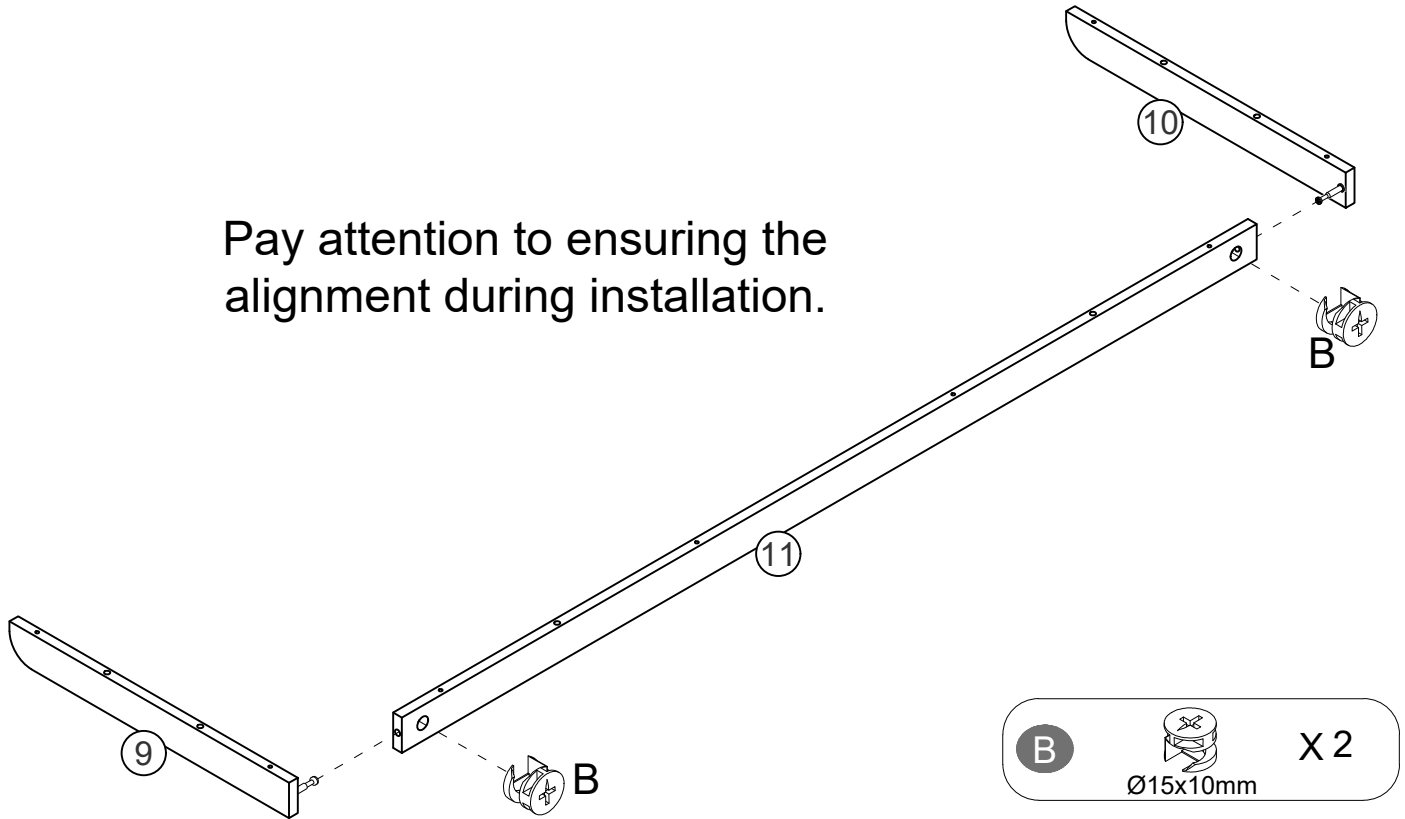

# STEP 14

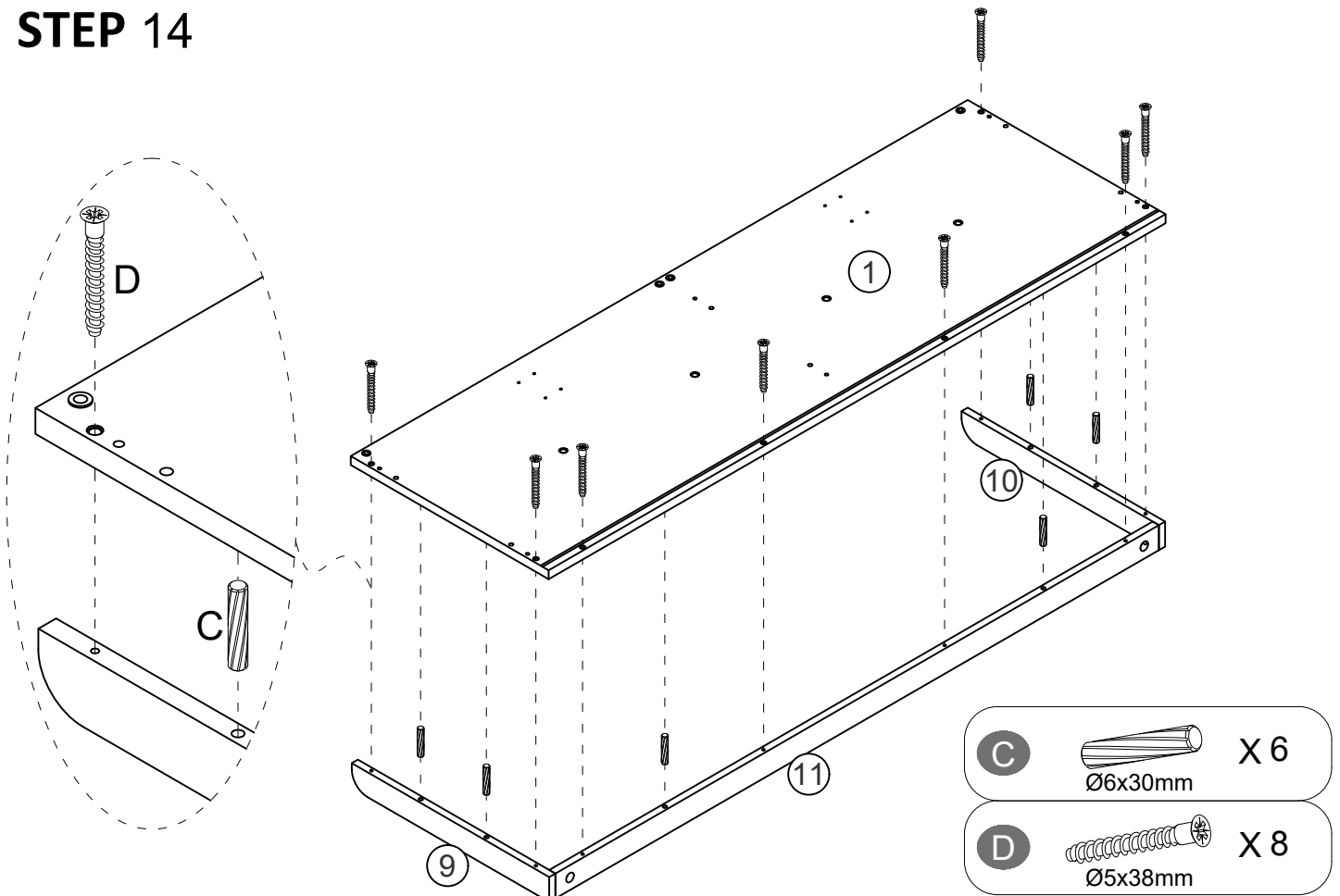

# STEP 15

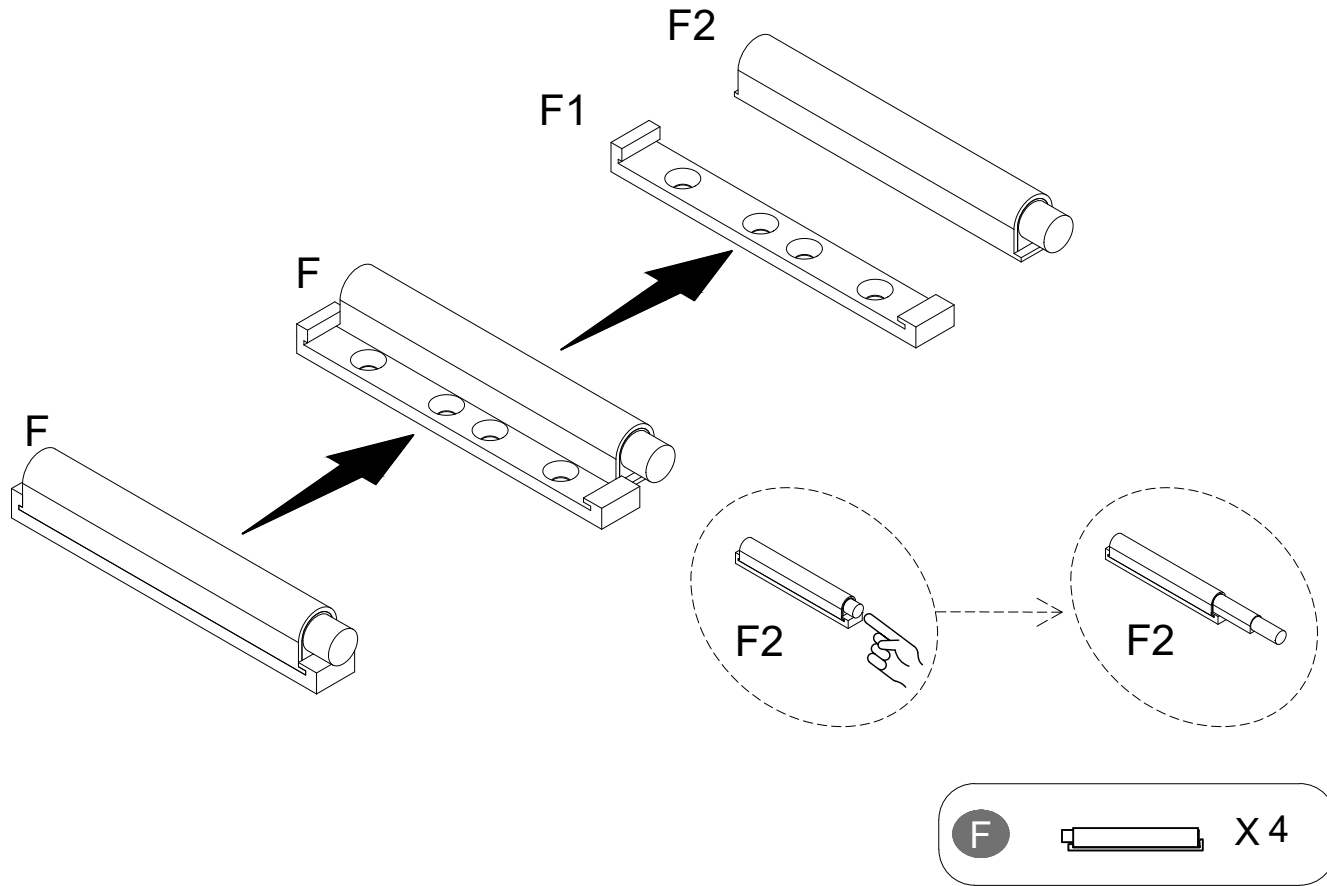

# STEP 16

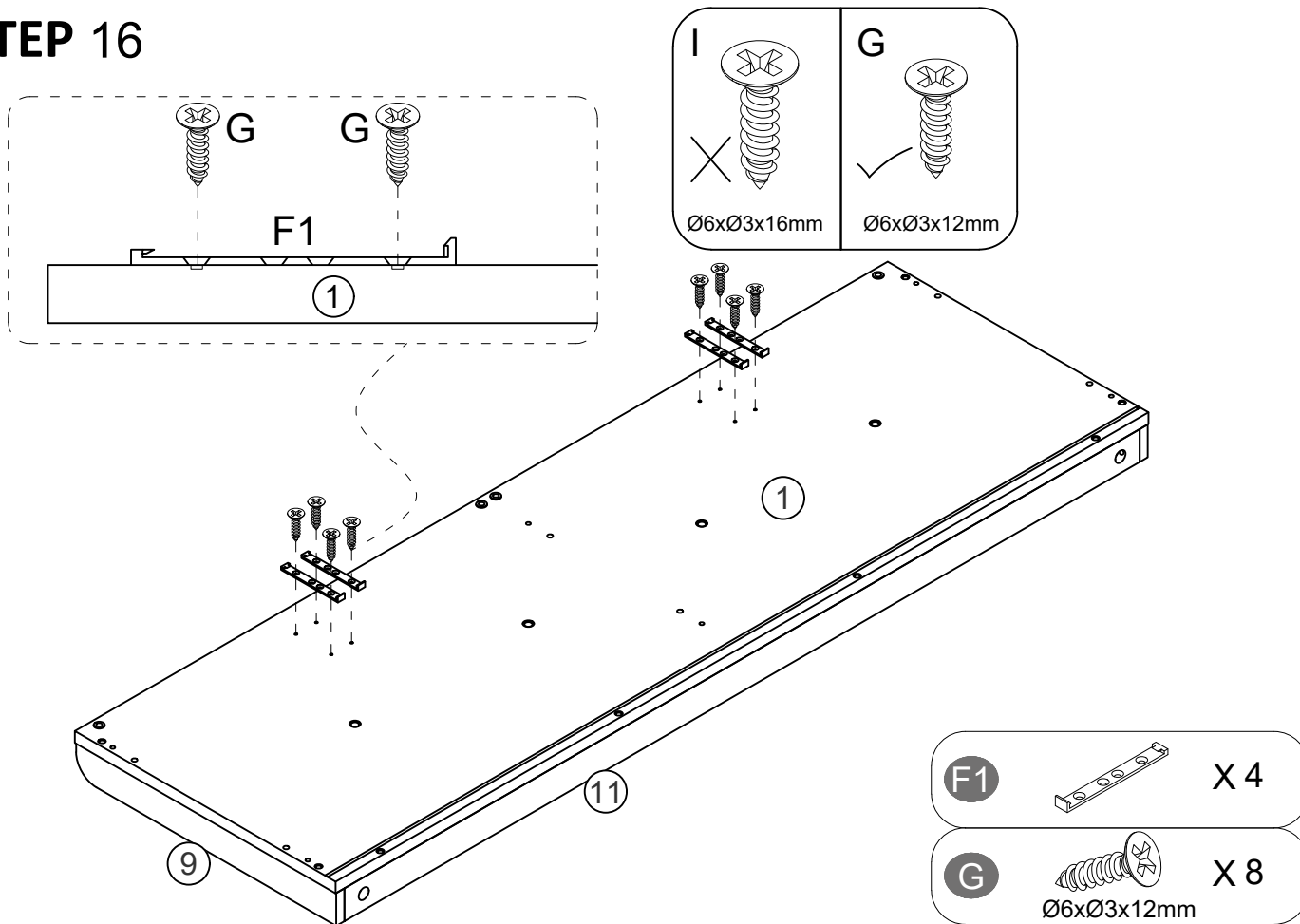

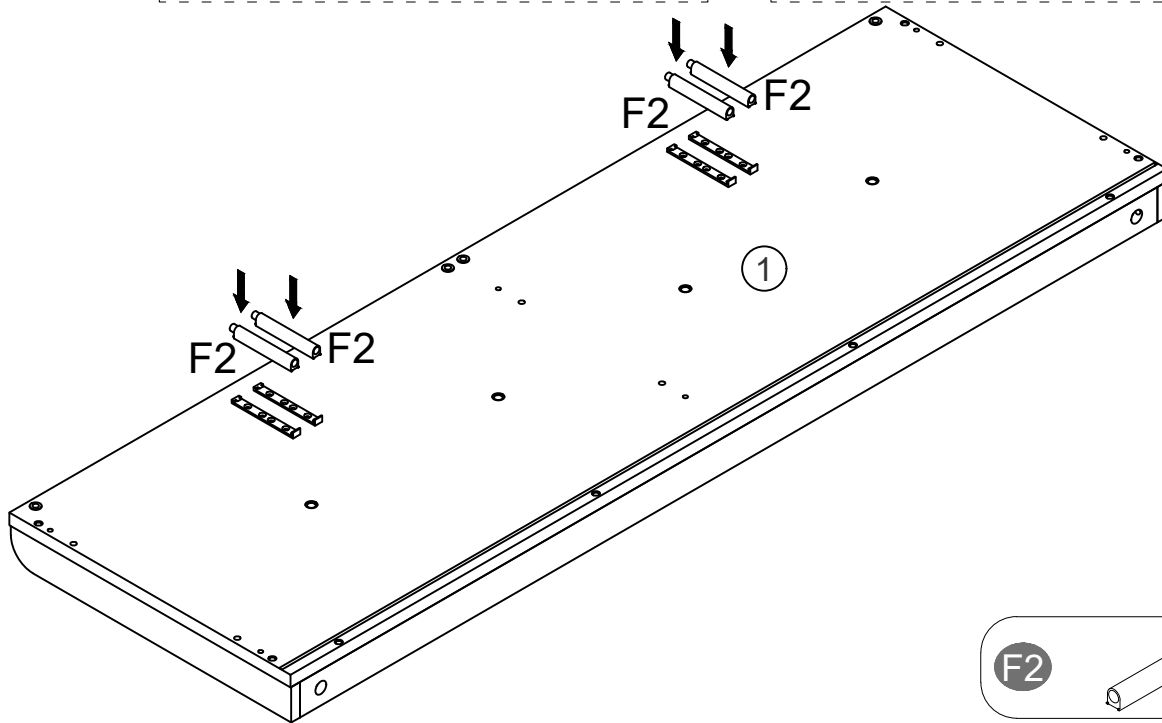
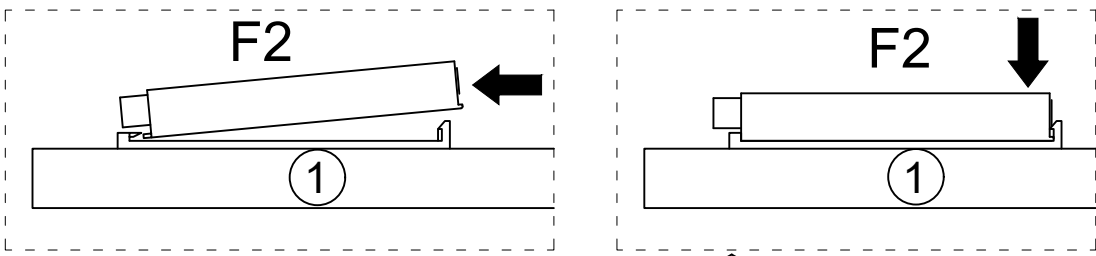

# STEP 17

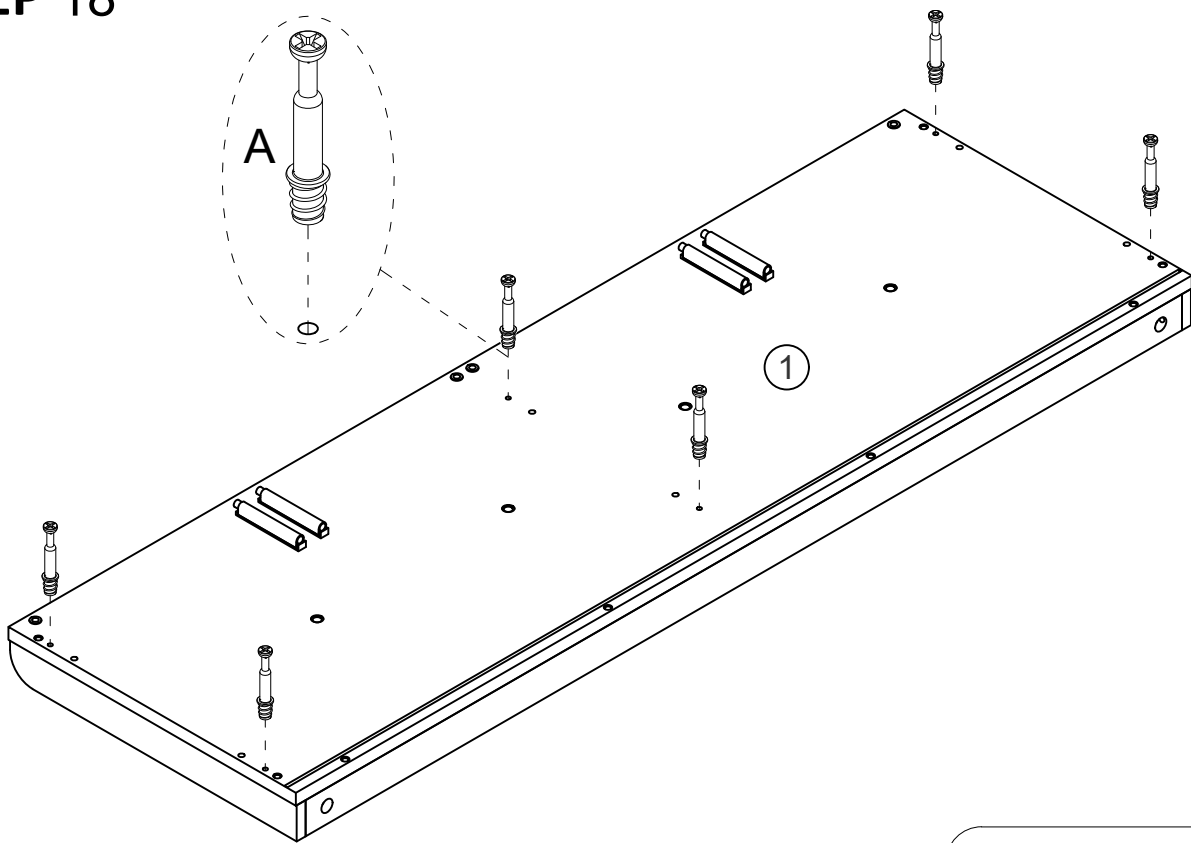
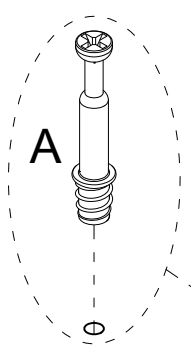

F2  X 4

# STEP 18



A  X 6  
Ø6x35mm

# STEP 19

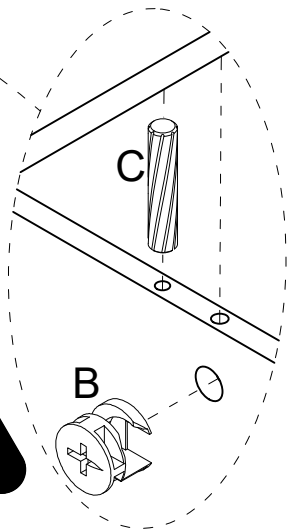
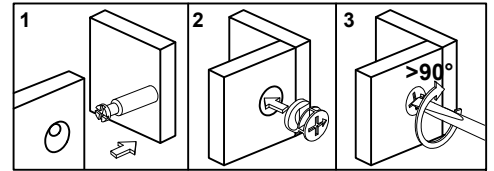
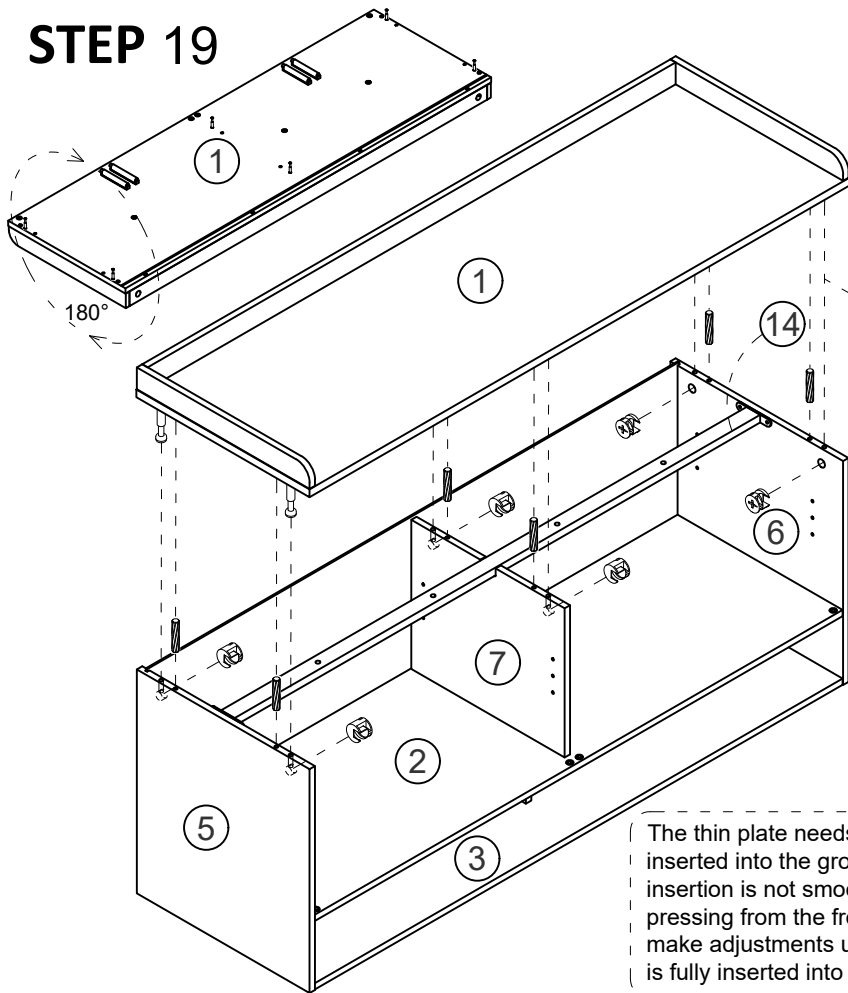

The thin plate needs to be fully inserted into the groove. If the insertion is not smooth, you can try pressing from the front or the back to make adjustments until the thin plate is fully inserted into the groove.

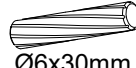
- B**  X 6  
Ø15x10mm
- C**  X 6  
Ø6x30mm

# STEP 20

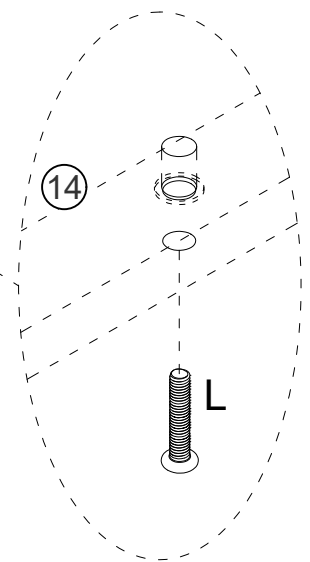
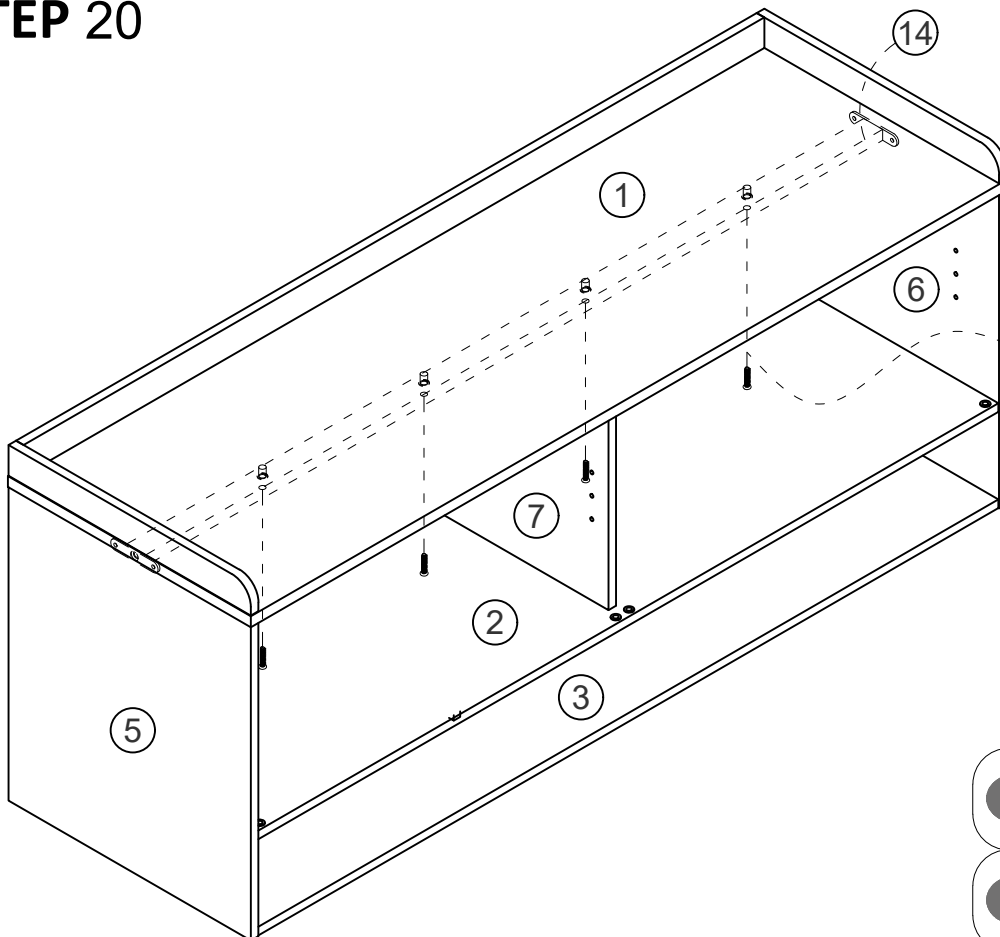

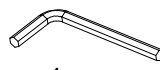
- L**  X 4  
M6x25mm
- O**  X 1  
4mm

# STEP 21

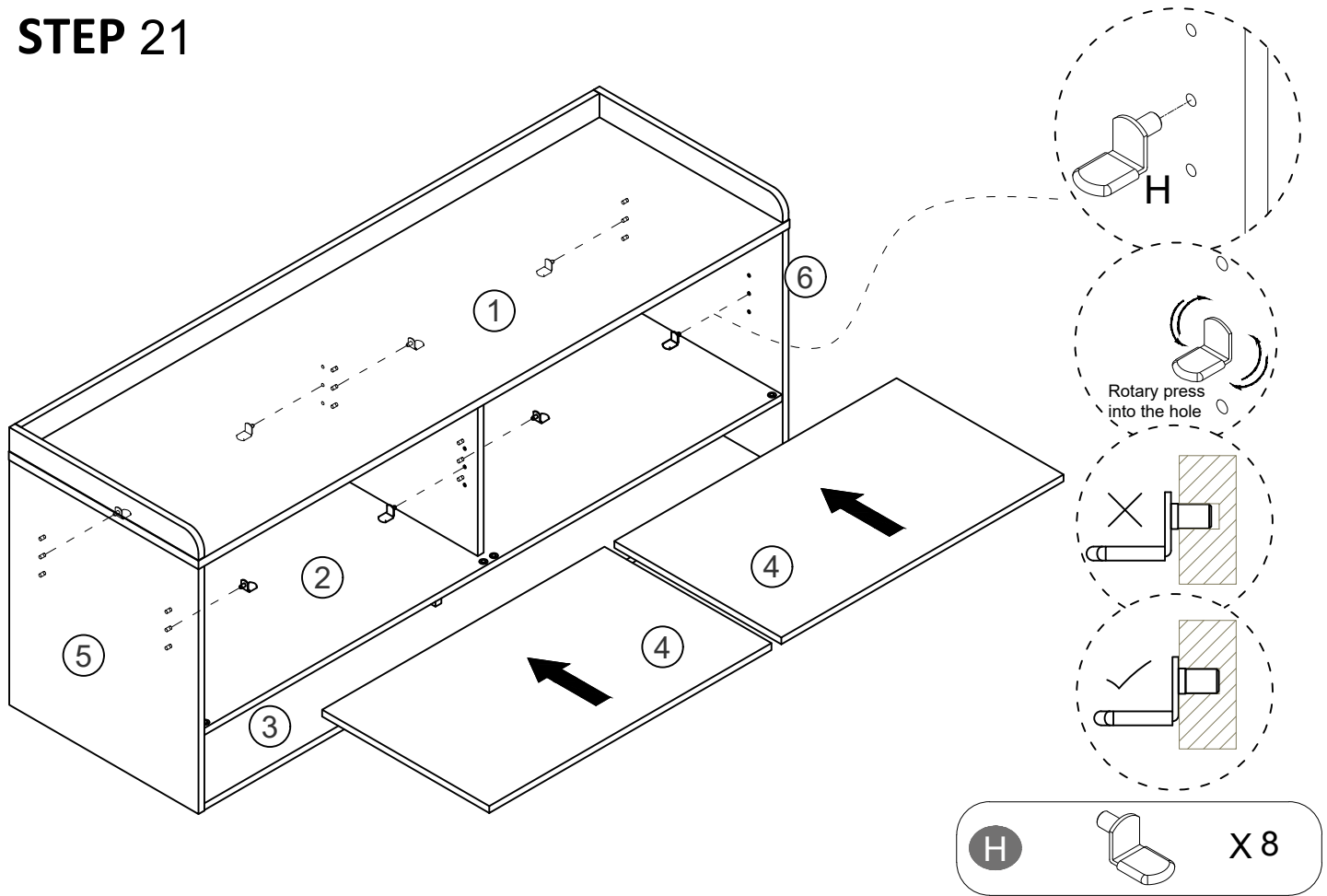

# STEP 22

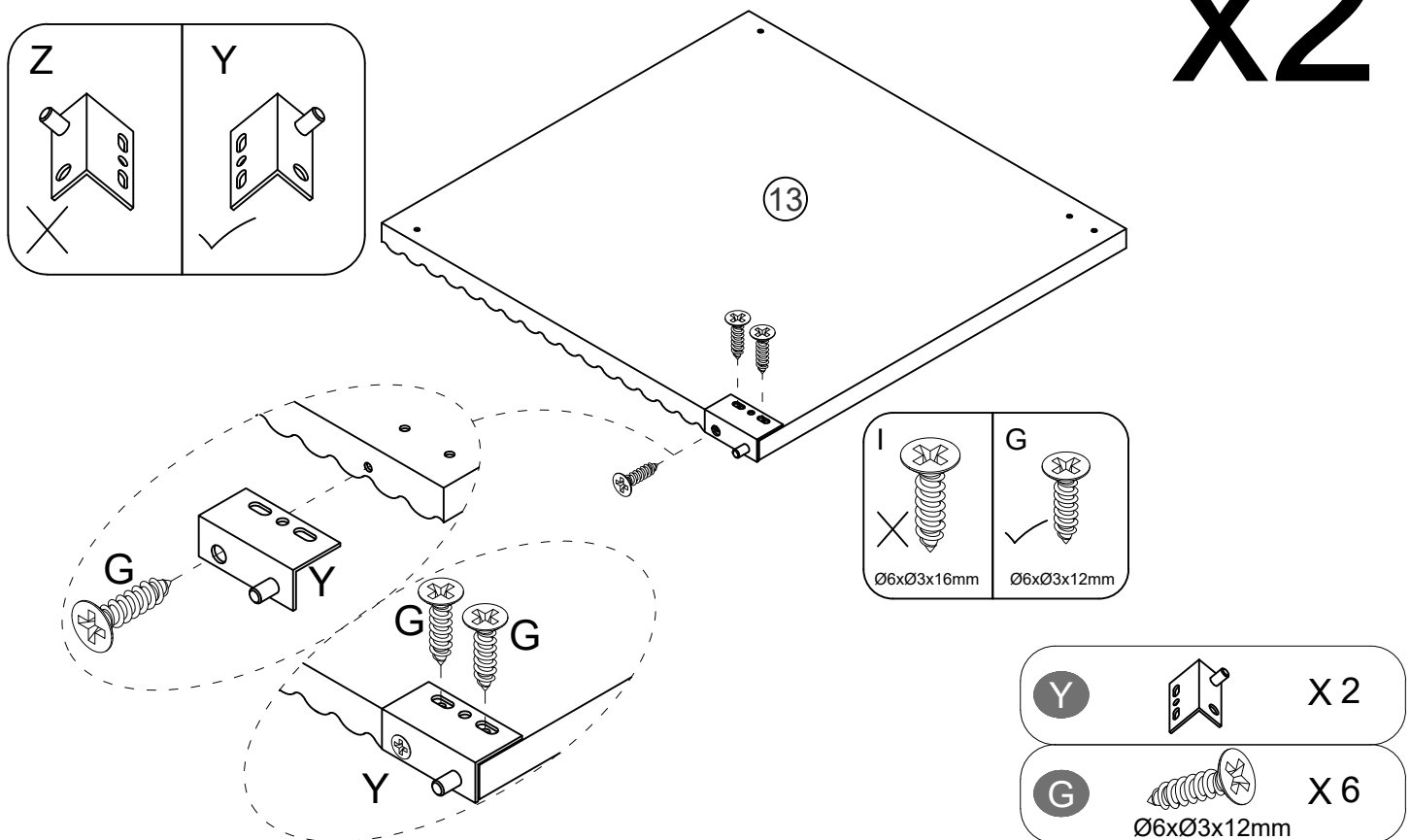

x2

# STEP 23

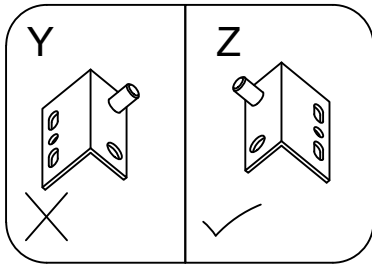

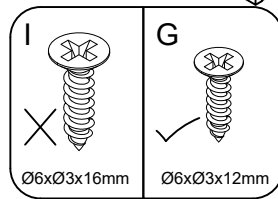
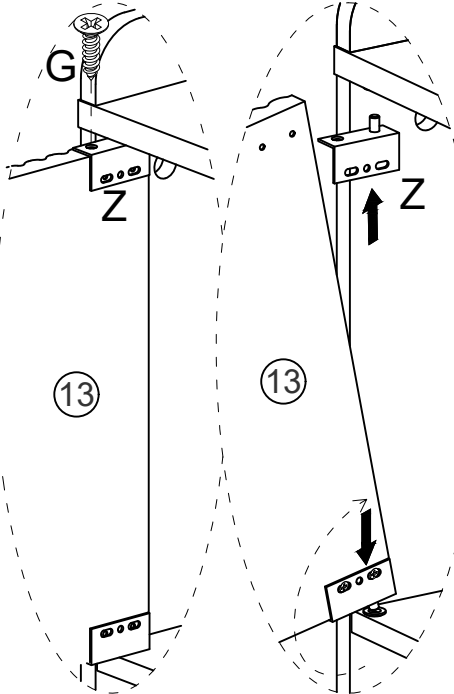
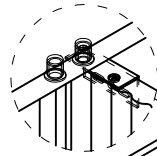

Be sure to check the correct hole positions.

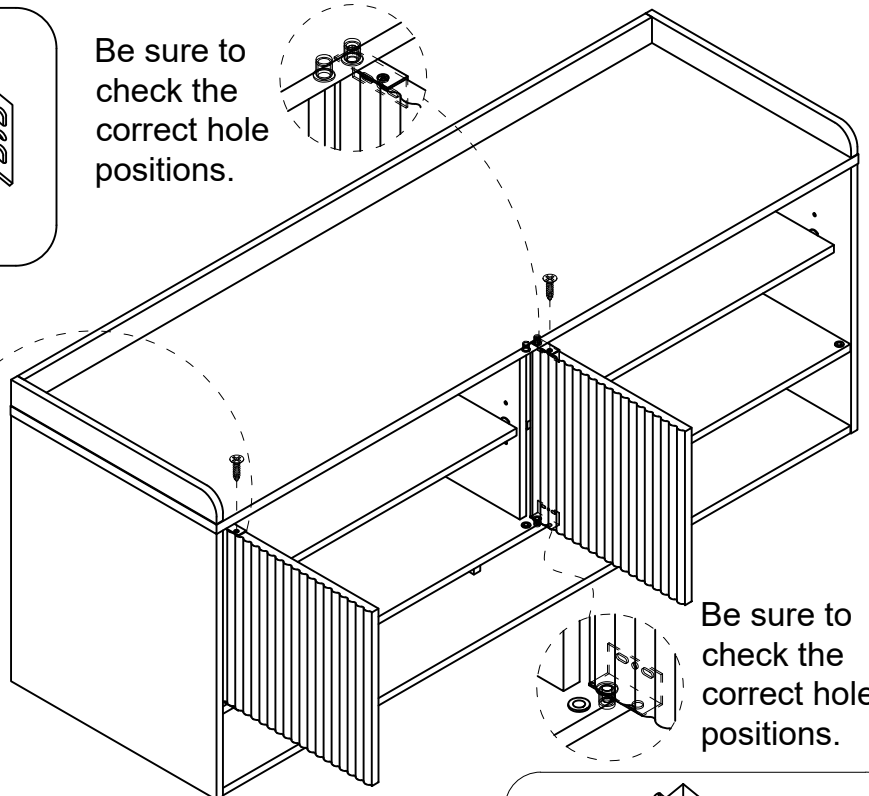

Ø6xØ3x16mm    Ø6xØ3x12mm



Be sure to check the correct hole positions.

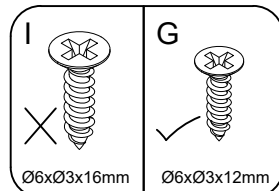

- Z**  X 2
- G**  X 2  
Ø6xØ3x12mm

# STEP 24

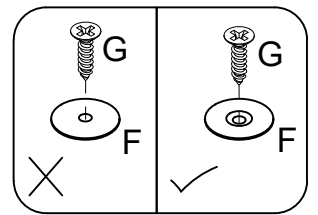
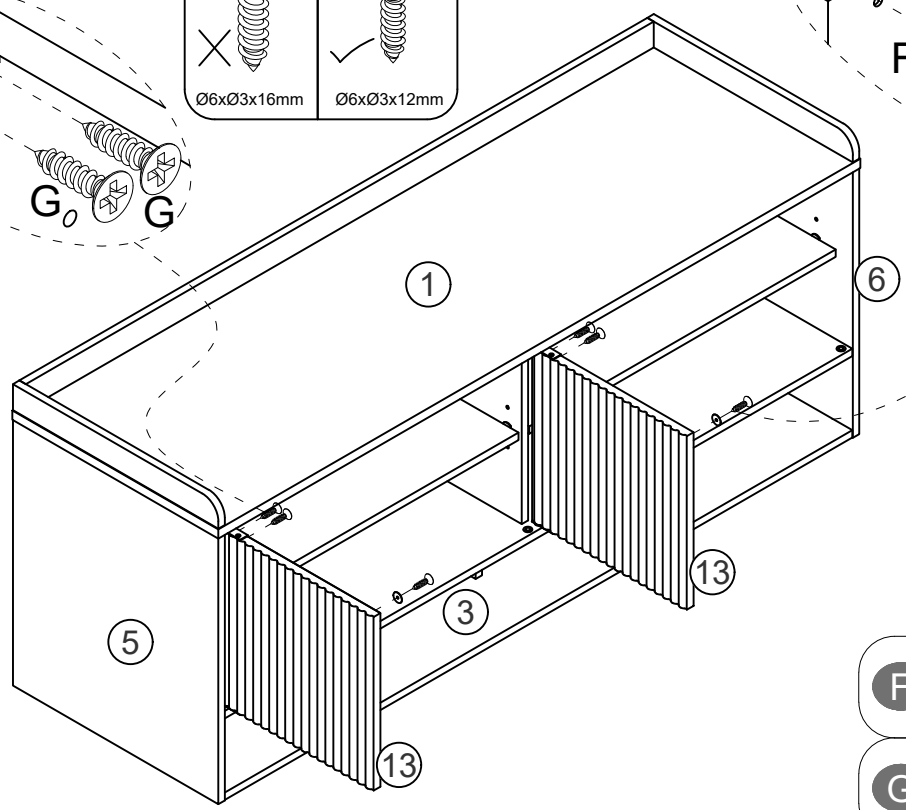
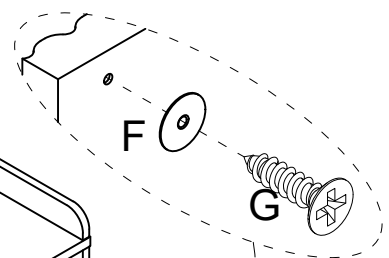
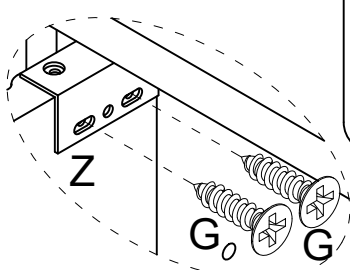

Ø6xØ3x16mm    Ø6xØ3x12mm



- F**  X 2
- G**  X 6  
Ø6xØ3x12mm

# STEP 25

# x2

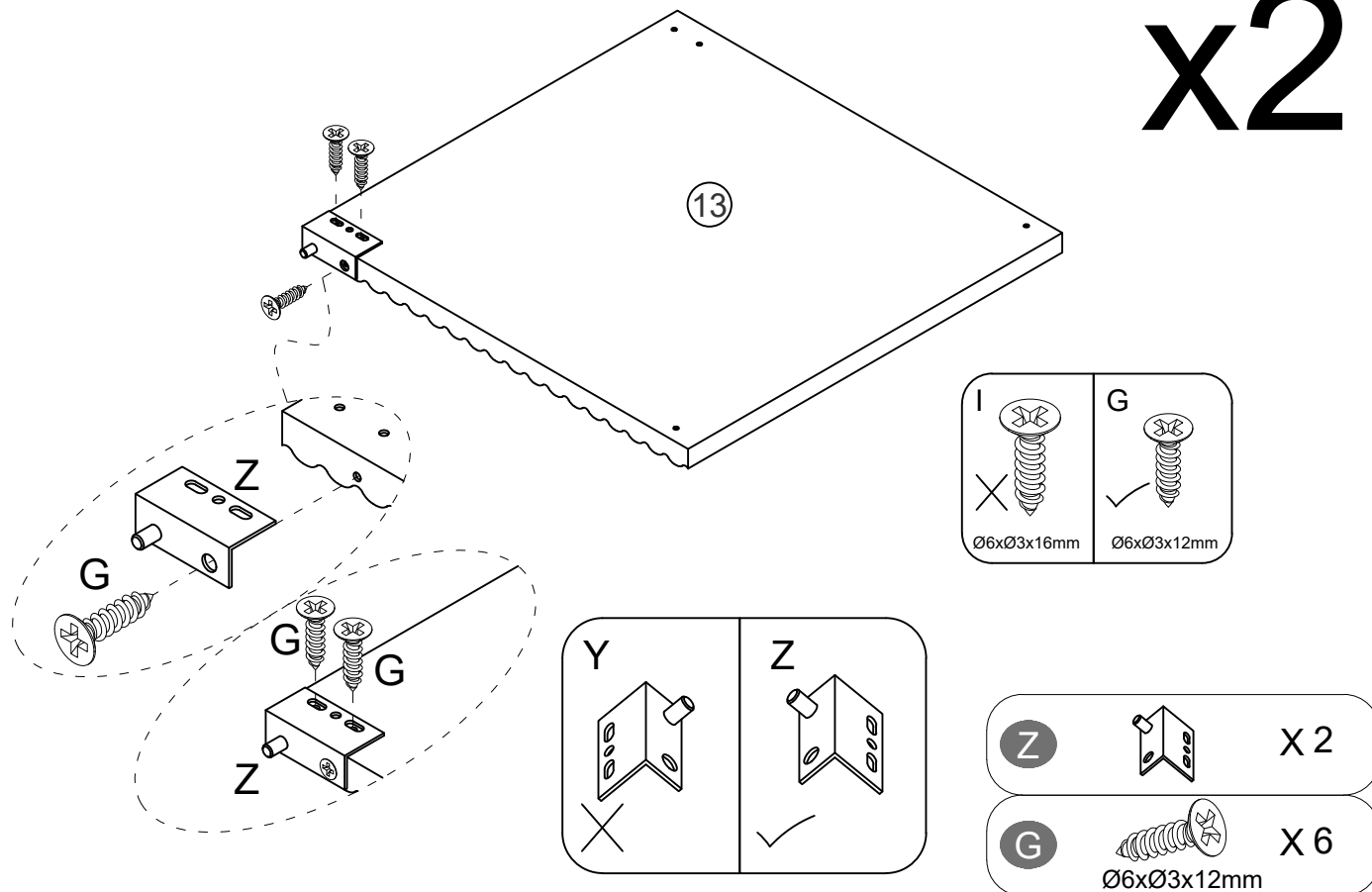

# STEP 26

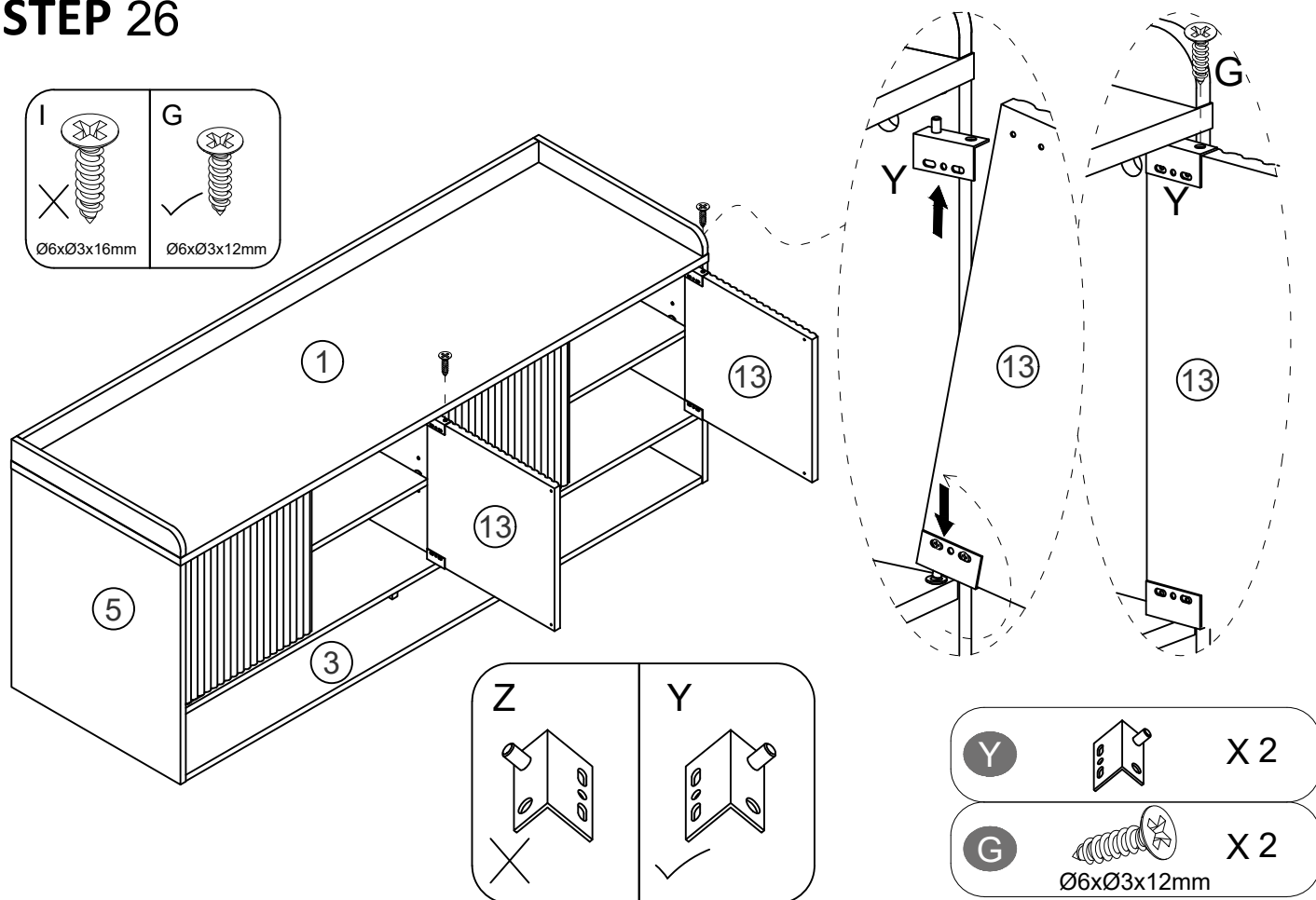

# STEP 27

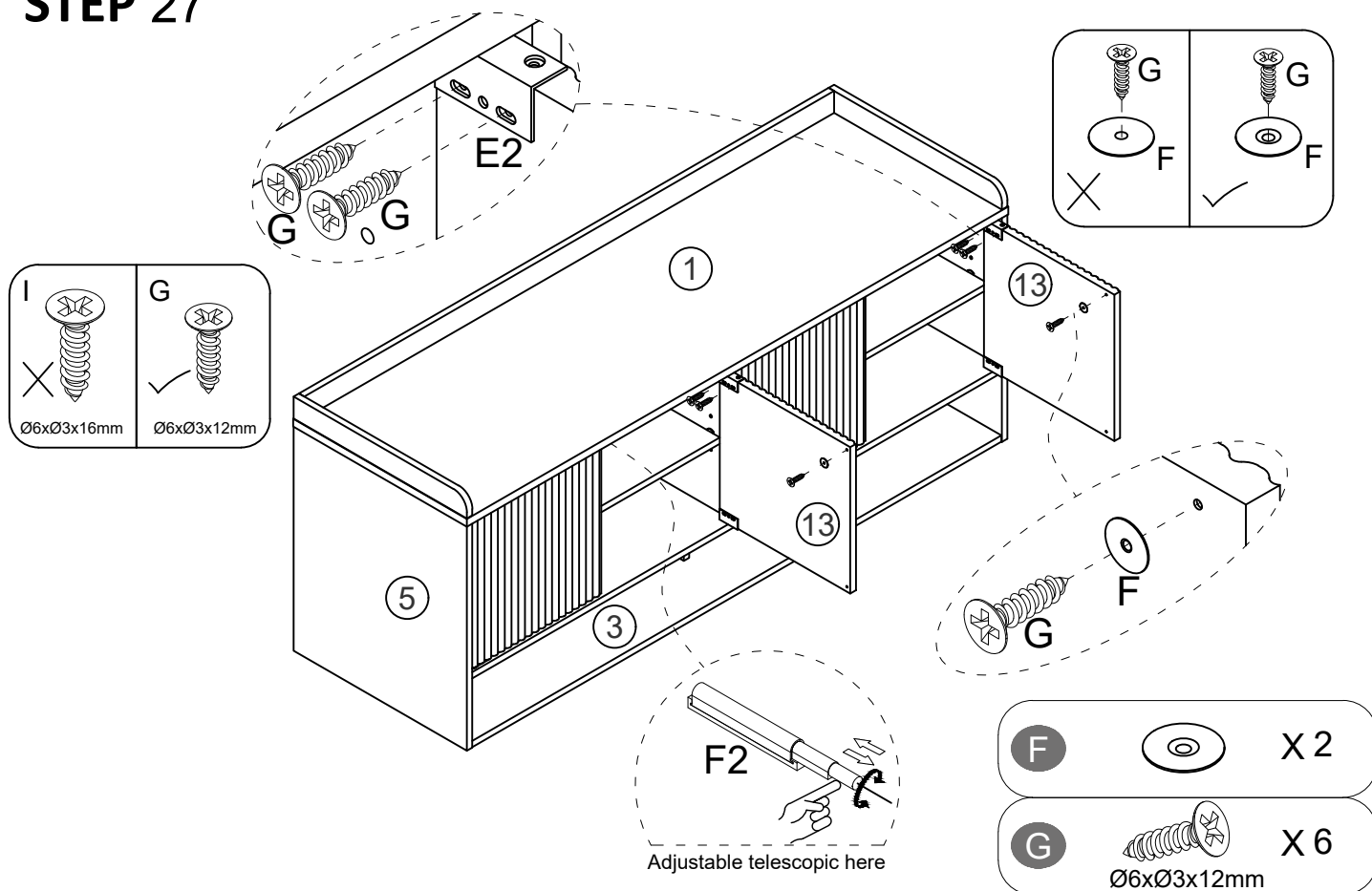

# STEP 28

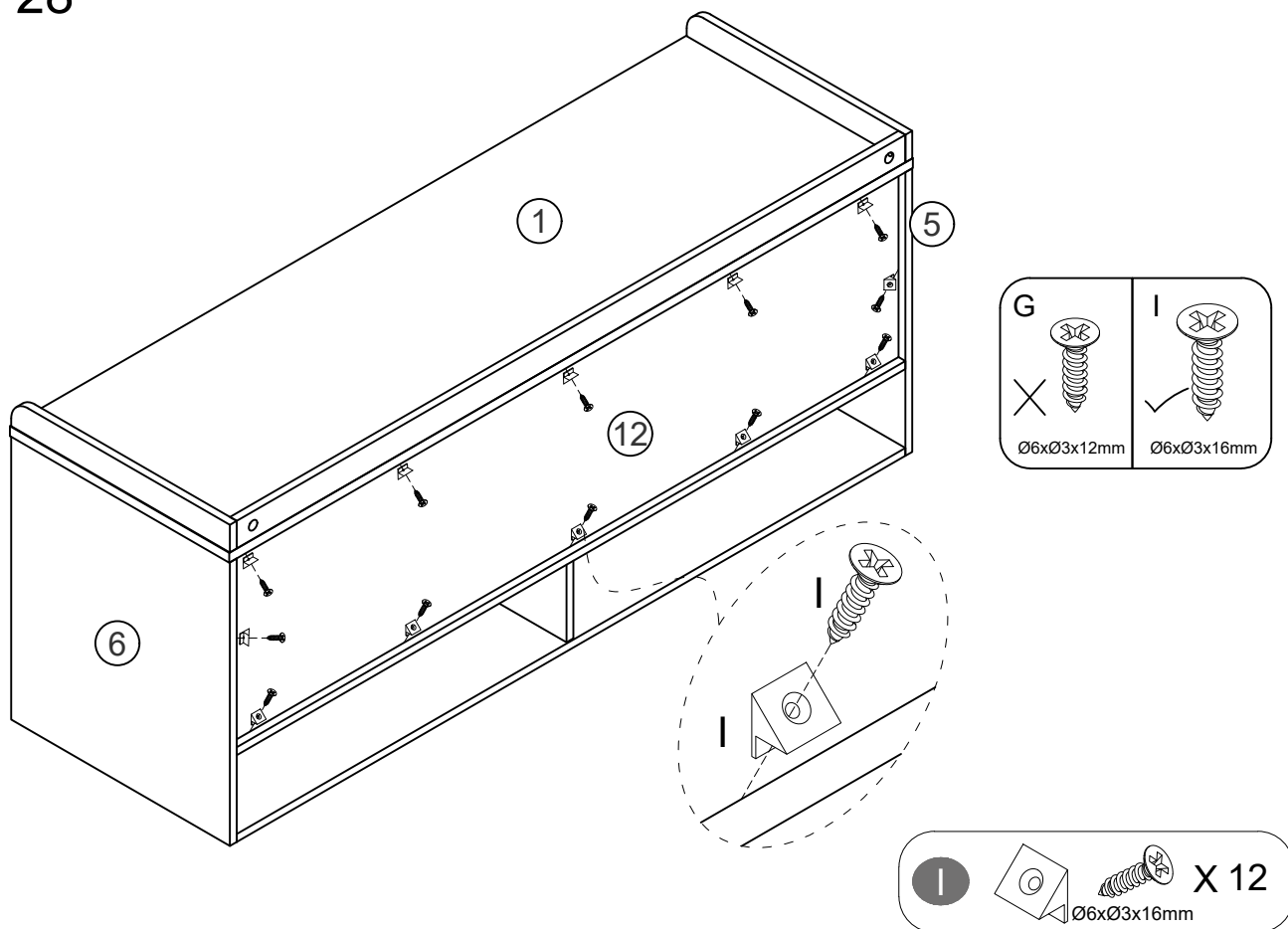

## STEP 29

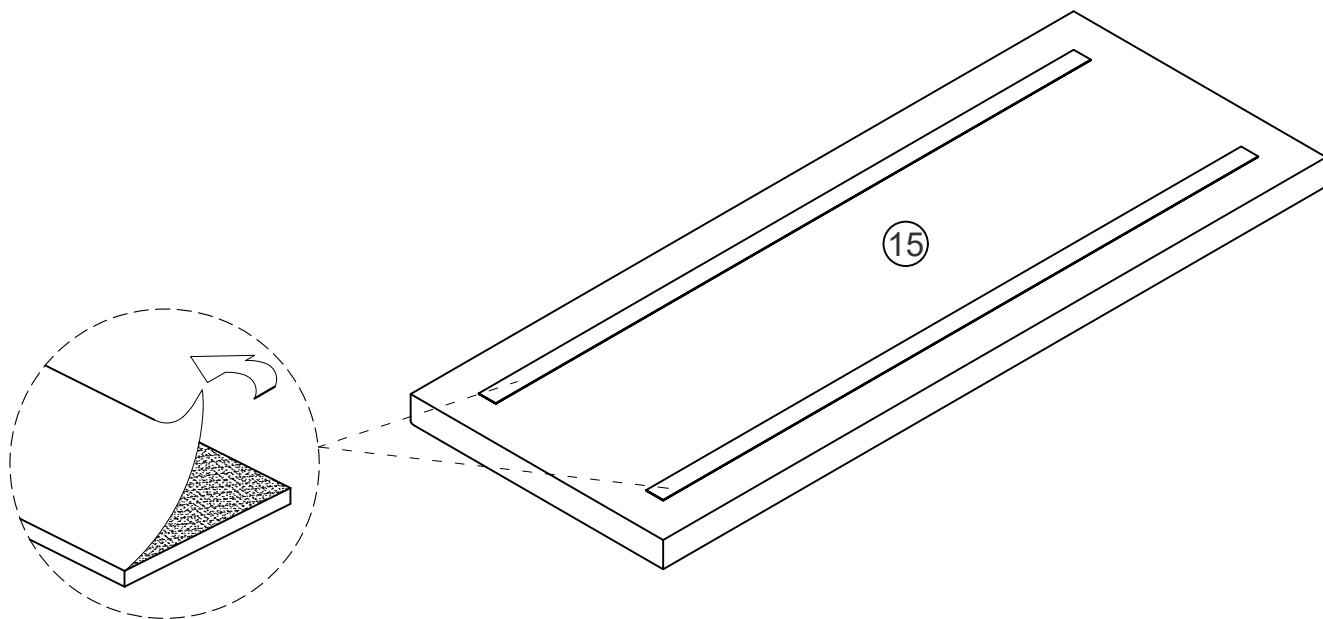

Remove the film from the surface

## STEP 30

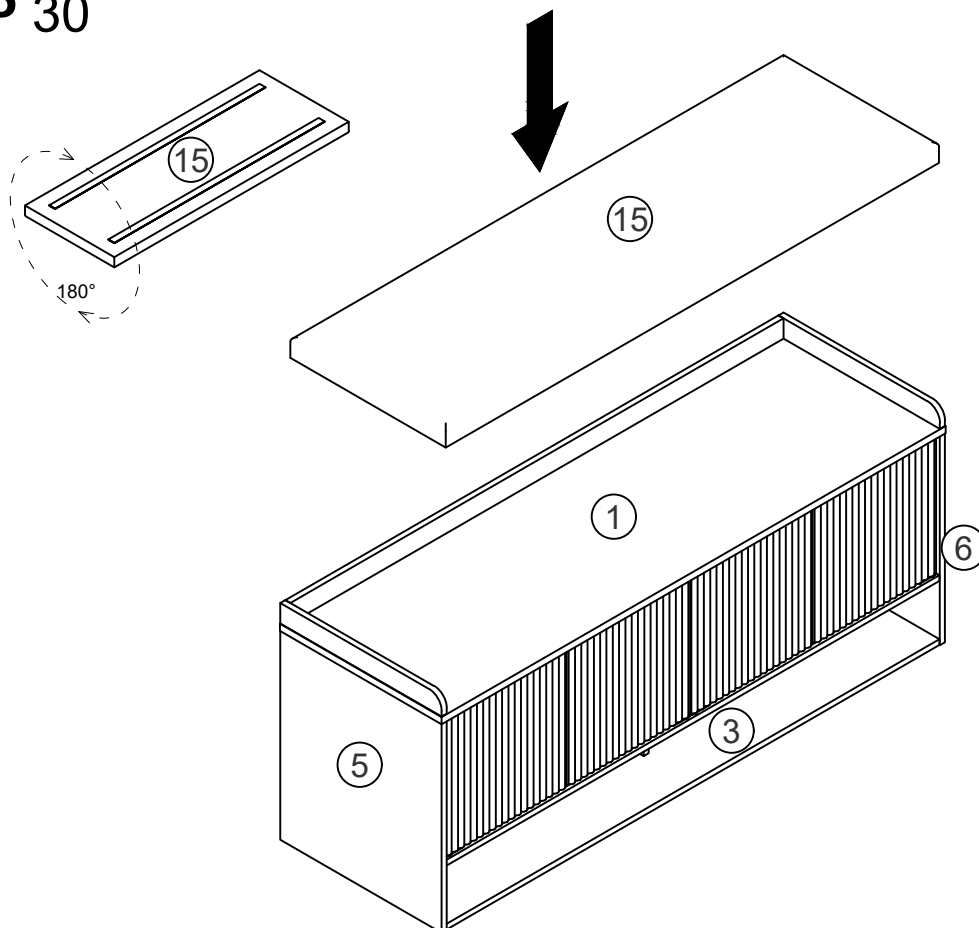

# STEP 31

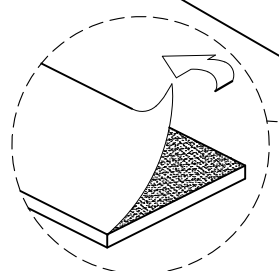
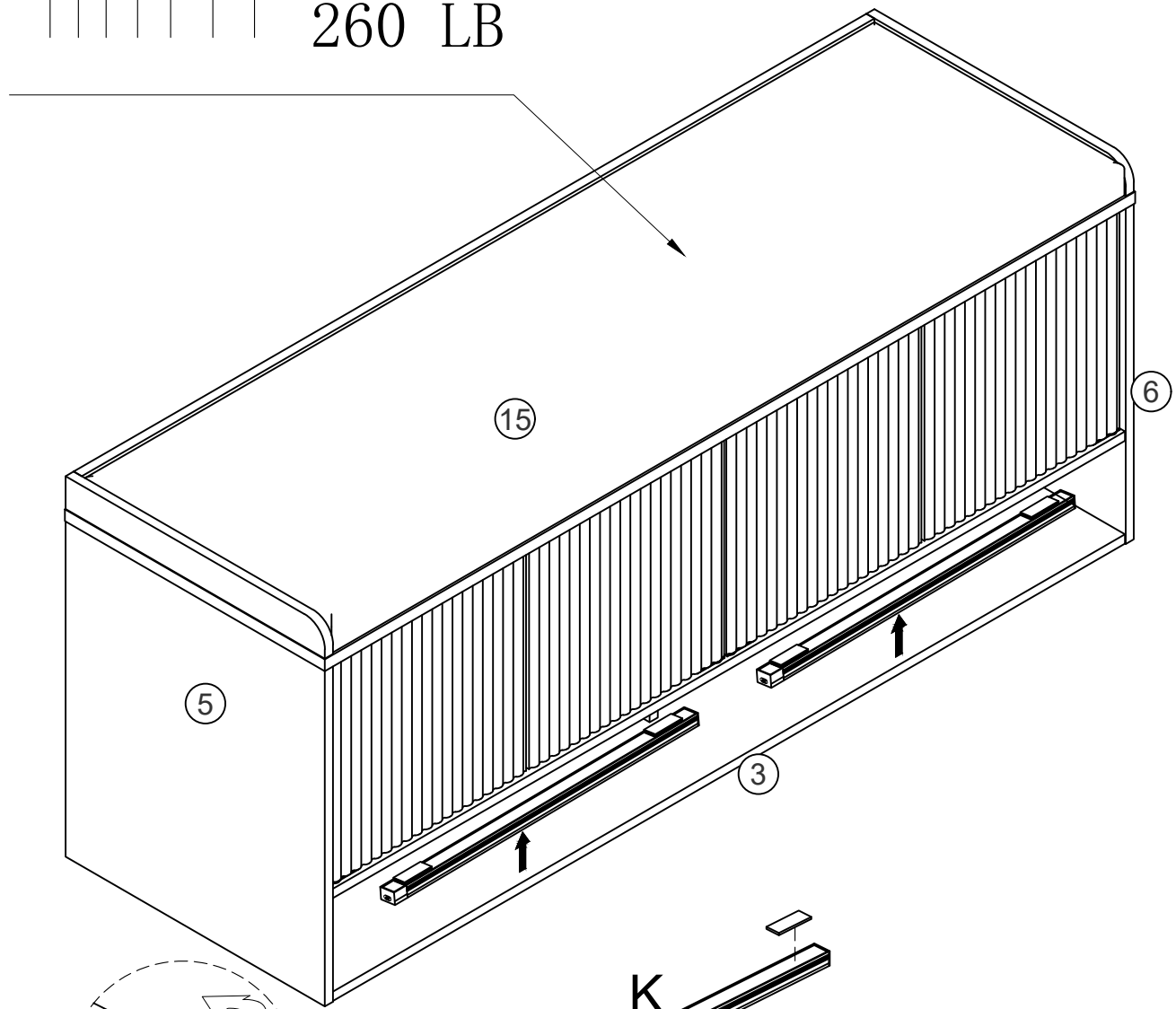
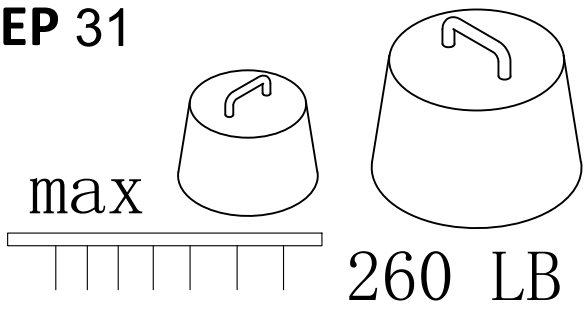

Remove the film on the back of the magnet before installation  
And adhere the magnet to the lamp strip

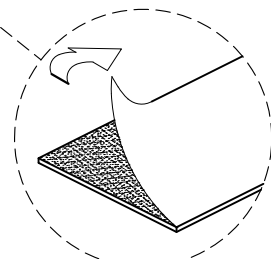
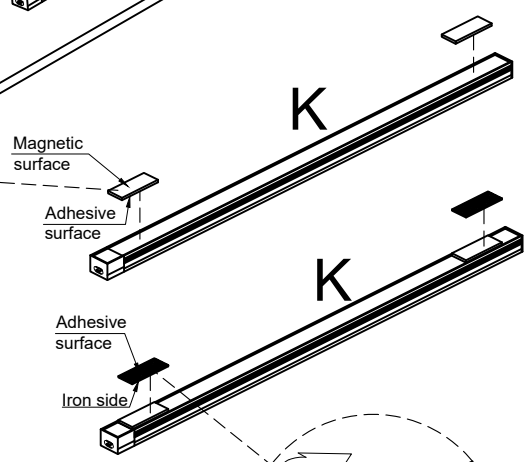

The film on the back of the iron sheet is removed and applied to the magnet

(K)  X 2