

EN_IMPORTANT, RETAIN FOR FUTURE REFERENCE: READ CAREFULLY.

FR_IMPORTANT: A LIRE ATTENTIVEMENT ET A CONSERVER POUR VOUS Y REFRERER ULTERIEUREMENT

ES_IMPORTANTE, LEA DETENIDAMENTE Y GUARDE PARA FUTURAS REFERENCIAS.

PT_IMPORTANTE, GARDE PARA FUTURA REFERÊNCIA, LEIA ATENTAMENTE.

DE_WICHTIG! SORFGFÄLTIG LESEN UND FÜR SPÄTERES NACHSCHLAGEN AUFBEWAHREN.

IT_IMPORTANTE, LEGGERE E CONSERVARE QUESTO MANUALE D'ISTRUZIONE PER UN USO FUTURO.

PARTS

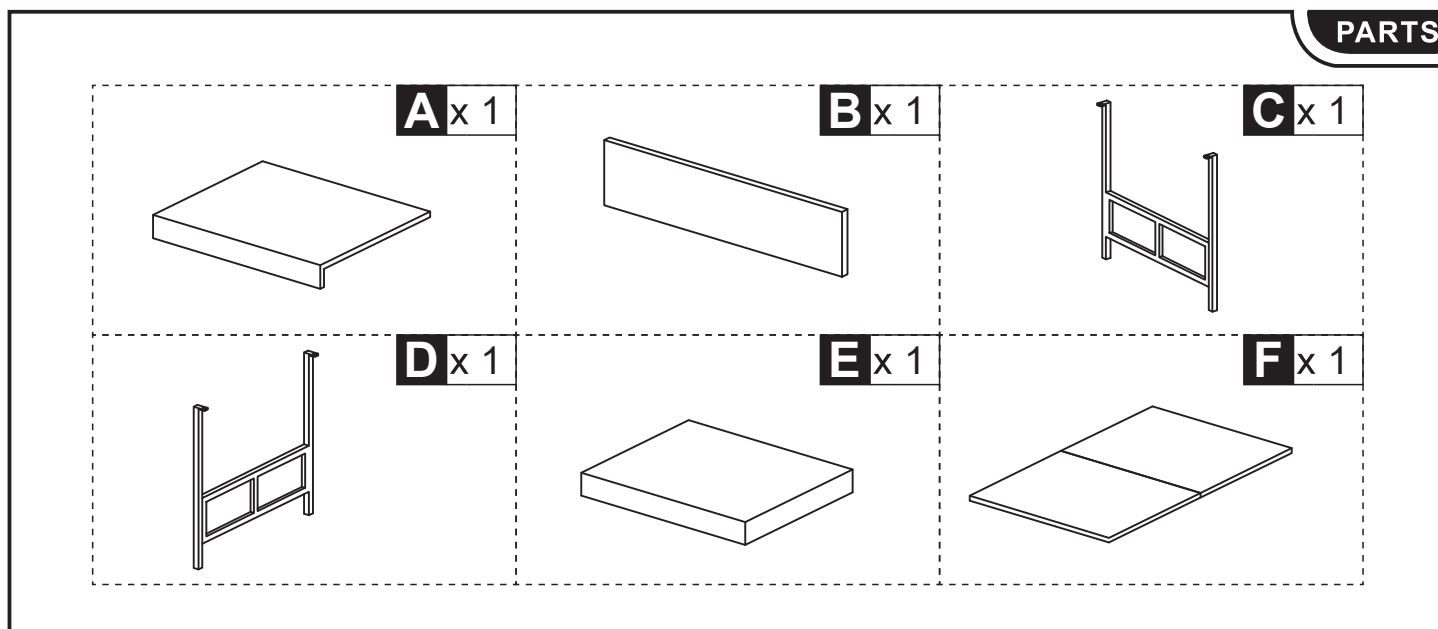

HARDWARE

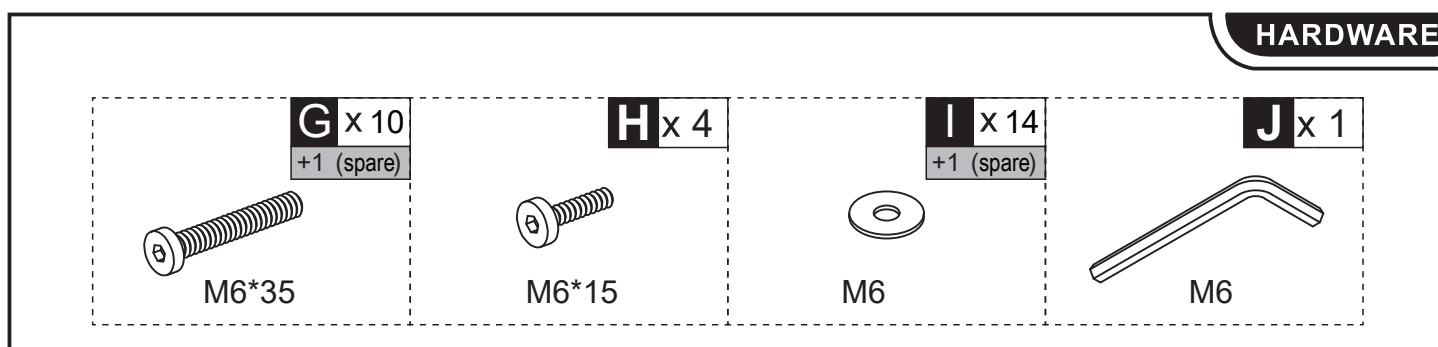

Do not tighten bolts fully until all parts are connected!

Ne serrez pas les boulons à fond tant que toutes les pièces ne sont pas connectées!

Ziehen Sie die Schrauben erst fest an, wenn alle Teile verbunden sind!

Non serrare completamente i bulloni fino a tutte le parti non sono ancora collegate!

No apriete los tornillos completamente hasta que todas las partes están conectadas!

Não apertar completamente os parafusos até que todas as peças estejam encaixadas!

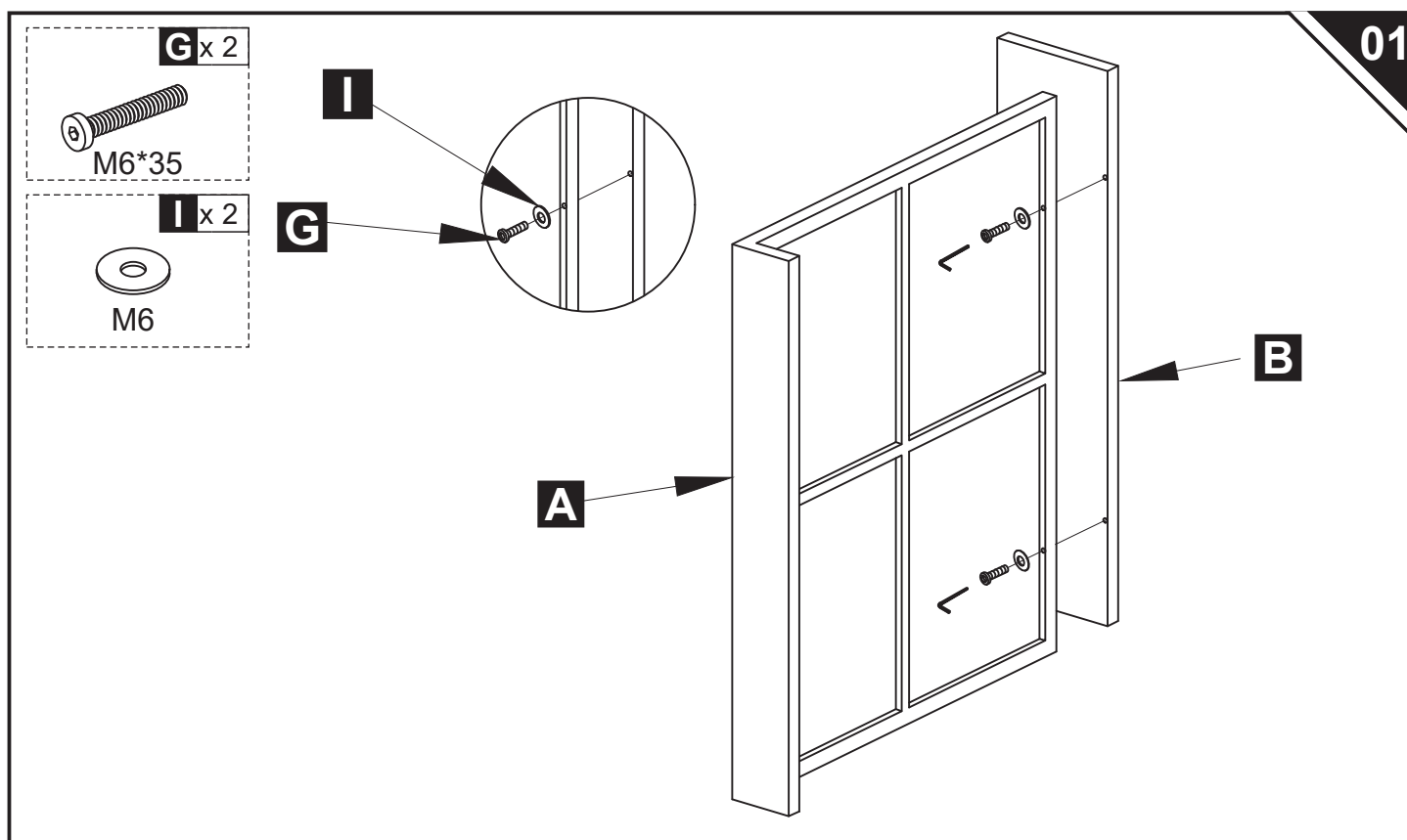

01

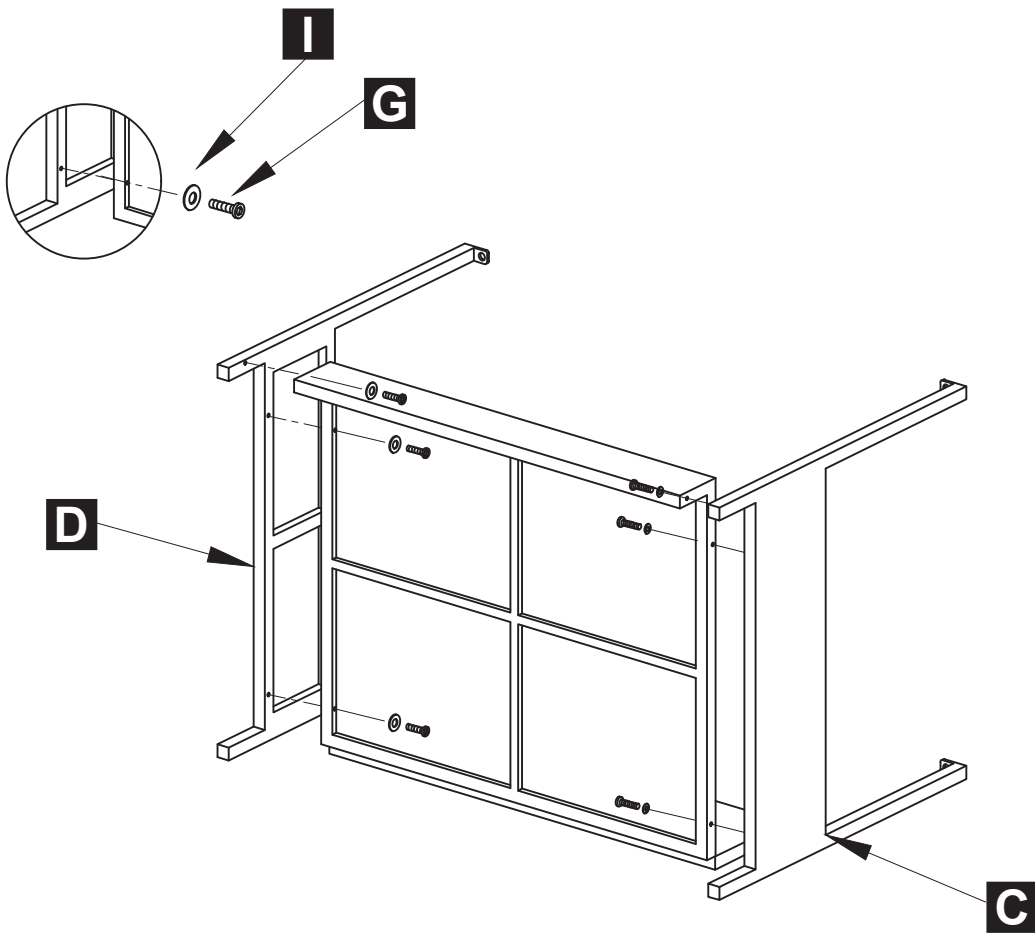
G x 8**I** x 8**H** x 4**I** x 4