

Version:1.0

DJ505510

DJ505511

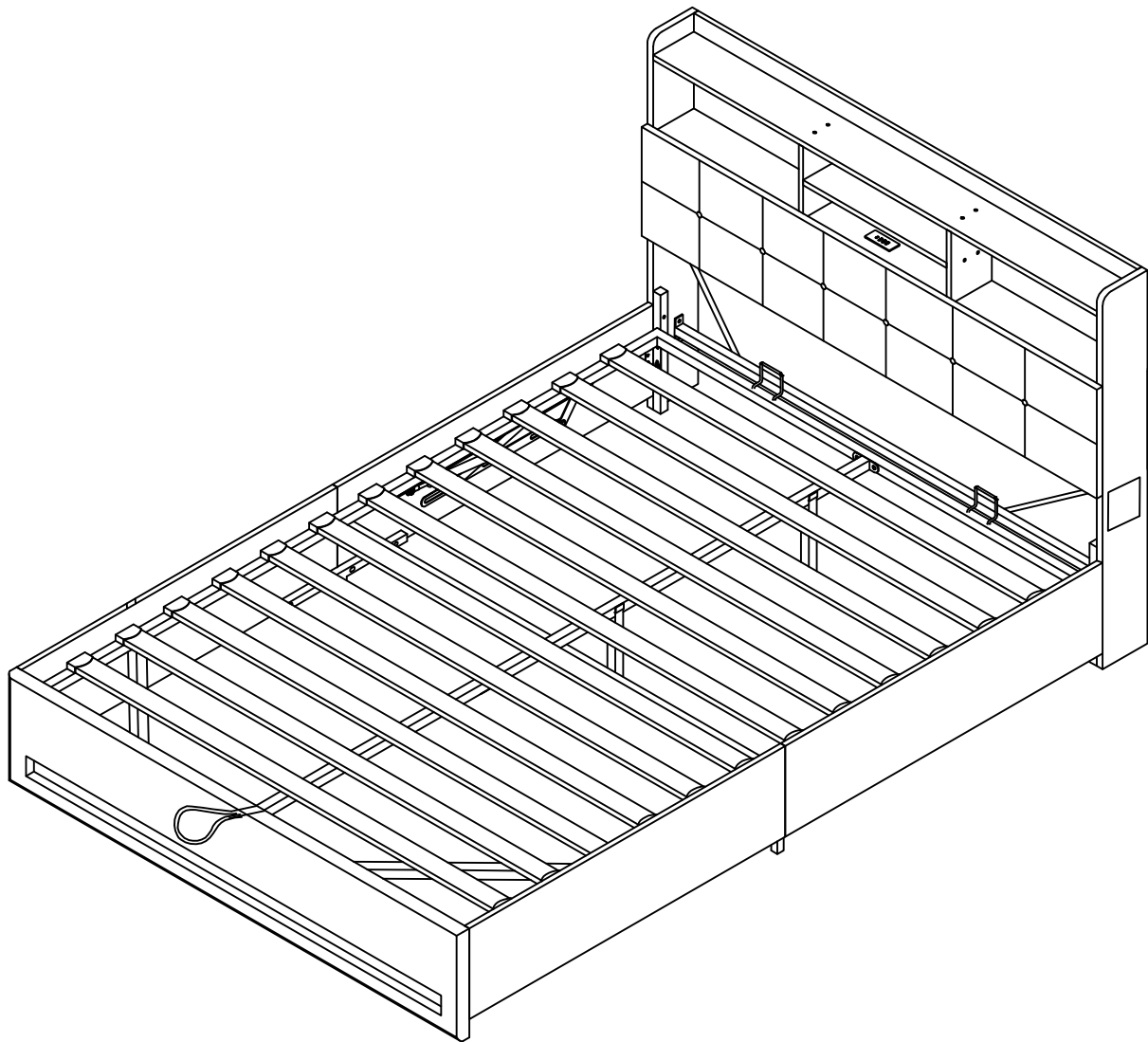

UK: The item will be delivered in 2 packages (A/B)

If you only receive one package,  
please be patient and wait for the second package

DE: Der Artikel wird in 2 Paketen (A/B) geliefert.

Wenn Sie nur ein Paket erhalten,  
haben Sie bitte etwas Geduld und warten Sie auf das zweite Paket.

FR : Livré en 2 colis(A/B)

Si vous ne recevez qu'un seul colis

Soyez patient pour la livraison du deuxième

IT: L'articolo verrà consegnato in 2 pacchi (A/B).

Se ricevi un solo pacco, sii paziente e attendi il secondo pacco.

ES: El artículo se entregará en 2 paquetes (A/B).

Si solo recibe un paquete, tenga paciencia y espere a que llegue el segundo.

## Warnung

- Das Produkt muss gemäß den Schritten und Empfehlungen in der Anleitung installiert und verwendet werden. Der Verkäufer übernimmt keine Verantwortung für Verletzungen oder Schäden, die durch unsachgemäße Montage oder unsachgemäße Verwendung durch den Benutzer entstehen.
- Kinder dürfen dieses Produkt nicht zusammenbauen. Während des Zusammenbaus sind alle Kleinteile außerhalb der Reichweite von Kindern zu halten, um ein Verschlucken oder Einatmen und damit verbundene Verletzungen zu vermeiden.
- Bitte halten Sie Plastikverpackungen von Kindern fern, um Erstickungsgefahr beim Spielen zu vermeiden.
- Bitte tragen Sie während des Zusammenbaus/Abbaus Handschuhe, um Schnittverletzungen zu vermeiden.
- Bitte bauen Sie das Produkt auf einer großzügigen Fläche zusammen und stellen Sie das unverpackte Produkt nicht direkt auf den Boden, um Beschädigungen zu vermeiden.
- Bitte vermeiden Sie langfristige Feuchtigkeit, um Schimmelbildung und Verformung zu verhindern.
- Bitte halten Sie das Produkt von scharfen Gegenständen und korrosiven Substanzen fern.
- Bitte Überprüfen Sie während der Nutzung regelmäßig den festen Sitz der Schrauben. Ziehen Sie lose Schrauben erneut fest, um die strukturelle Integrität zu gewährleisten.
- Berücksichtigen Sie je nach Möbeltyp und Einsatzumgebung die Verwendung von Befestigungselementen, um das Möbelstück an der Wand oder anderen Gegenständen zu fixieren und ein Umkippen zu verhindern.
- Stellen Sie das Produkt während der Nutzung auf eine ebene und feste Unterlage.

## Avertissements

- Veuillez suivre le manuel d'utilisation pour assembler et utiliser le produit. Le vendeur décline toute responsabilité ou obligation pour tout dommage/blessure résultant d'un mauvais montage ou utilisation
- Il est interdit aux enfants d'assembler ce produit. Veuillez garder toutes les petites pièces hors de portée des enfants lors de l'assemblage pour prévenir tous risques mortels causés par l'ingestion ou l'inhalation accidentelles
- Pour éviter tout risque potentiel d'étouffement, veuillez garder les sacs plastiques hors de portée des enfants
- Veuillez porter des gants avant d'assembler ou de démonter le produit pour éviter de vous blesser par les bords tranchants
- Veuillez assembler le produit sur une surface plane et spacieuse et ne pas placer les pièces déballées directement sur le sol pour éviter les rayures ou dommage
- Veuillez éviter son exposition prolongée à l'humidité pour éviter la moisissure
- Veuillez garder le produit à l'écart des objets tranchants et pointus ou des substances corrosives pour éviter tout dommage
- Veuillez vérifier régulièrement si toutes les vis sont bien serrées lors d'utilisation. En cas de nécessité, resserrez-les pour assurer l'intégrité de la structure
- Veuillez fixer le produit au mur ou à d'autres objets en fonction du type de meuble et de l'environnement d'utilisation avec le dispositif anti-basculement fourni pour éviter tout basculement
- Veuillez placer le produit sur une surface plane et solide lors de votre utilisation

## Warning

- The product must be installed and used according to the steps and recommendations in the instructions. The seller assumes no responsibility for any injury or damage caused by improper assembly or improper use by the user.
- Children are not allowed to assemble this product. During assembly, all small parts should be kept out of the reach of children to avoid swallowing or inhaling and related injuries.
- Please keep plastic packaging away from children to avoid choking hazards when playing.
- Please wear gloves during assembly/disassembly to avoid cuts.
- Please assemble the product on a spacious area and do not place the unpacked product directly on the floor to avoid damage.
- Please avoid long-term moisture to prevent mold and deformation.
- Please keep the product away from sharp objects and corrosive substances.
- Please check the tightness of the screws regularly during use. Re-tighten loose screws to ensure structural integrity.
- Depending on the type of furniture and the environment in which it is used, consider using fasteners to secure the furniture to the wall or other objects to prevent it from tipping over.
- Place the product on a flat and stable surface during use.

## advertencia

- El producto debe instalarse y utilizarse según los pasos y recomendaciones de las instrucciones. El vendedor no asume ninguna responsabilidad por lesiones o daños resultantes de un montaje inadecuado o un uso inadecuado por parte del usuario.
- No se permite que los niños monten este producto. Durante el montaje, todas las piezas pequeñas deben mantenerse fuera del alcance de los niños para evitar asfixia o inhalación y lesiones asociadas.
- Mantenga los envases de plástico fuera del alcance de los niños para evitar el riesgo de asfixia cuando juegan.
- Utilice guantes durante el montaje/desmontaje para evitar cortes.
- Monte el producto en un área espaciosa y no coloque el producto desembalado directamente en el suelo para evitar daños.
- Evite la humedad a largo plazo para evitar el moho y la deformación.
- Mantenga el producto alejado de objetos punzantes y sustancias corrosivas.
- Compruebe periódicamente el apriete de los tornillos durante el uso. Vuelva a apretar los tornillos flojos para garantizar la integridad estructural.
- Dependiendo del tipo de mueble y del entorno de uso, considere el uso de fijaciones para fijar el mueble a la pared u otros objetos y evitar que se vuelque.
- Colocar el producto sobre una superficie plana y firme durante su uso.

## avvertimento

- Il prodotto deve essere installato e utilizzato secondo i passaggi e le raccomandazioni contenute nelle istruzioni. Il venditore non si assume alcuna responsabilità per eventuali lesioni o danni derivanti da un montaggio improprio o da un uso improprio da parte dell'utente.
- I bambini non sono autorizzati a montare questo prodotto. Durante il montaggio, tutte le piccole parti devono essere tenute fuori dalla portata dei bambini per evitare soffocamento o inalazione e lesioni correlate.
- Si prega di tenere gli imballaggi di plastica lontano dalla portata dei bambini per evitare il rischio di soffocamento durante il gioco.
- Si prega di indossare guanti durante il montaggio/smontaggio per evitare tagli.
- Si prega di montare il prodotto su un'area spaziosa e di non posizionare il prodotto disimballato direttamente a terra per evitare danni.
- Si prega di evitare l'umidità a lungo termine per prevenire muffe e deformazioni.
- Tenere il prodotto lontano da oggetti appuntiti e sostanze corrosive.
- Controllare regolarmente il serraggio delle viti durante l'uso. Stringere nuovamente le viti allentate per garantire l'integrità strutturale.
- A seconda del tipo di mobile e dell'ambiente di utilizzo, considerare l'uso di elementi di fissaggio per fissare il mobile alla parete o ad altri oggetti ed evitare che si ribalti.
- Posizionare il prodotto su una superficie piana e solida durante l'uso.

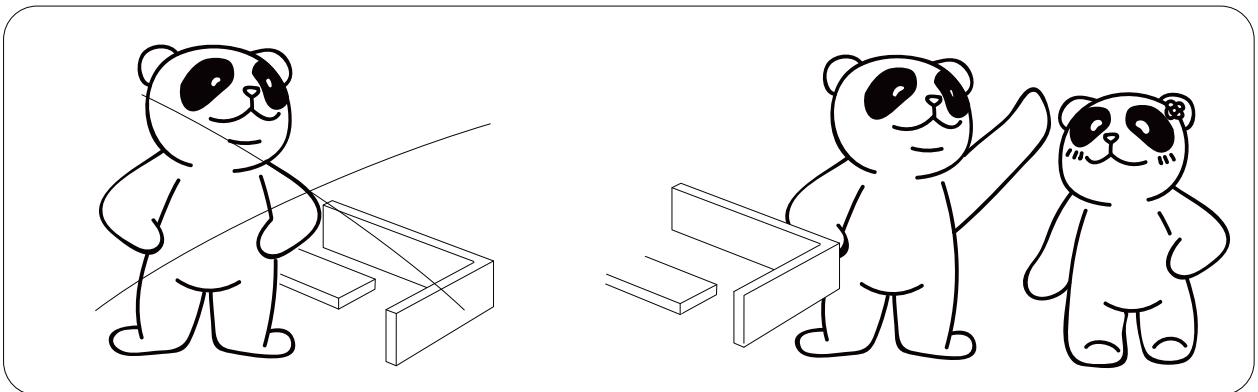
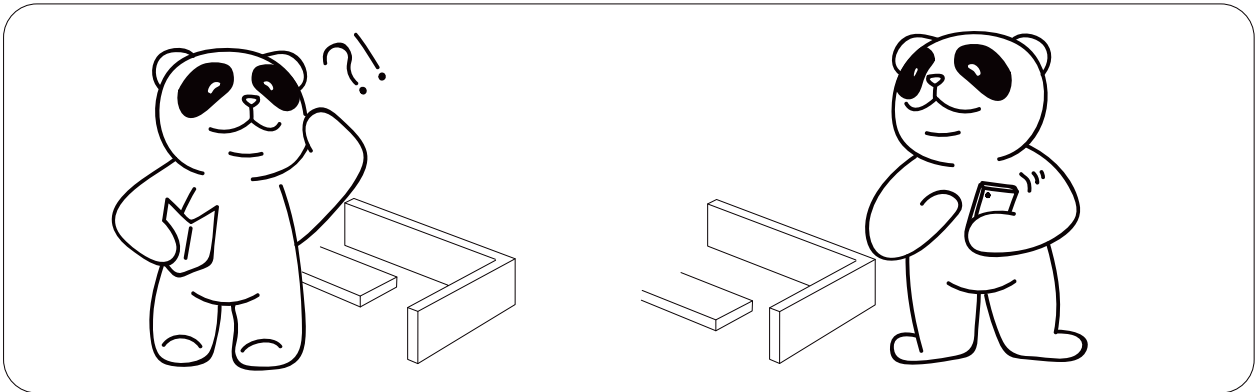
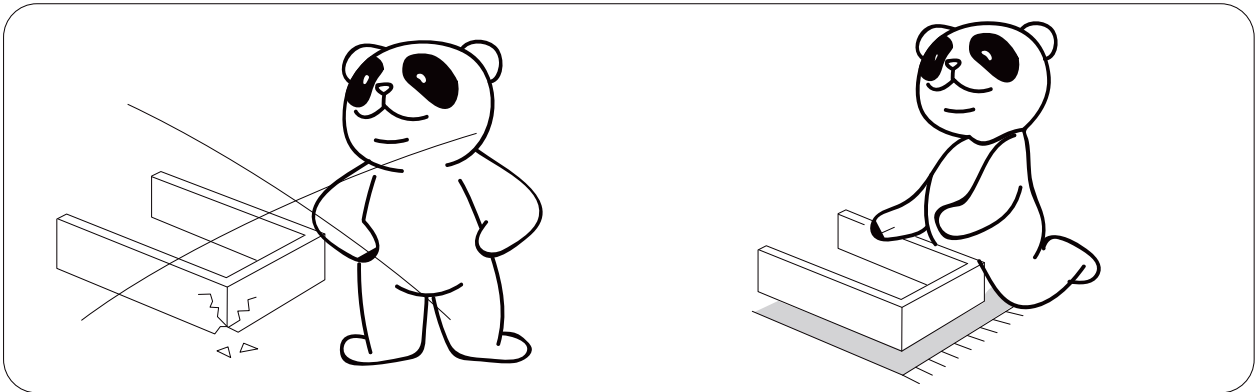
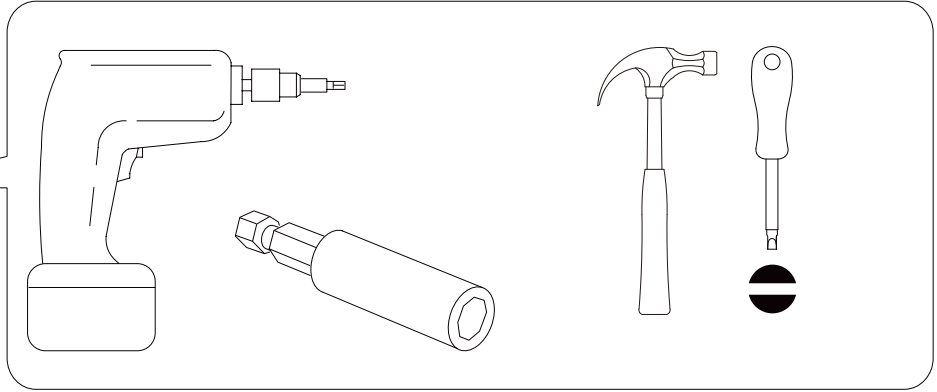

UK:Note:

- 1.should be assembled on flat ground to keep balance.
- 2.Before completing the installation,do not tighten the screws

DE:Anmerkung:

- 1.Die Montage des Produktes muss auf ebenem Untergrund durchgefuehrt werden, um das Gleichgewicht zu halten
- 2.Ziehen Sie die Schrauben bitte zuerst nicht an, bevor Sie die Montage abschließen.

FR:Note :

- 1.Veuillez l'assembler sur un sol plat pour maintenir l'équilibre
- 2.Ne serrez pas les vis avant la fin d' installation



2 PERS.

UK:It needs at least two people to install.

DE: Für die Montage sind mindestens zwei Erwachsene erforderlich.

FR:Il faut au moins Deux personnes à installer.







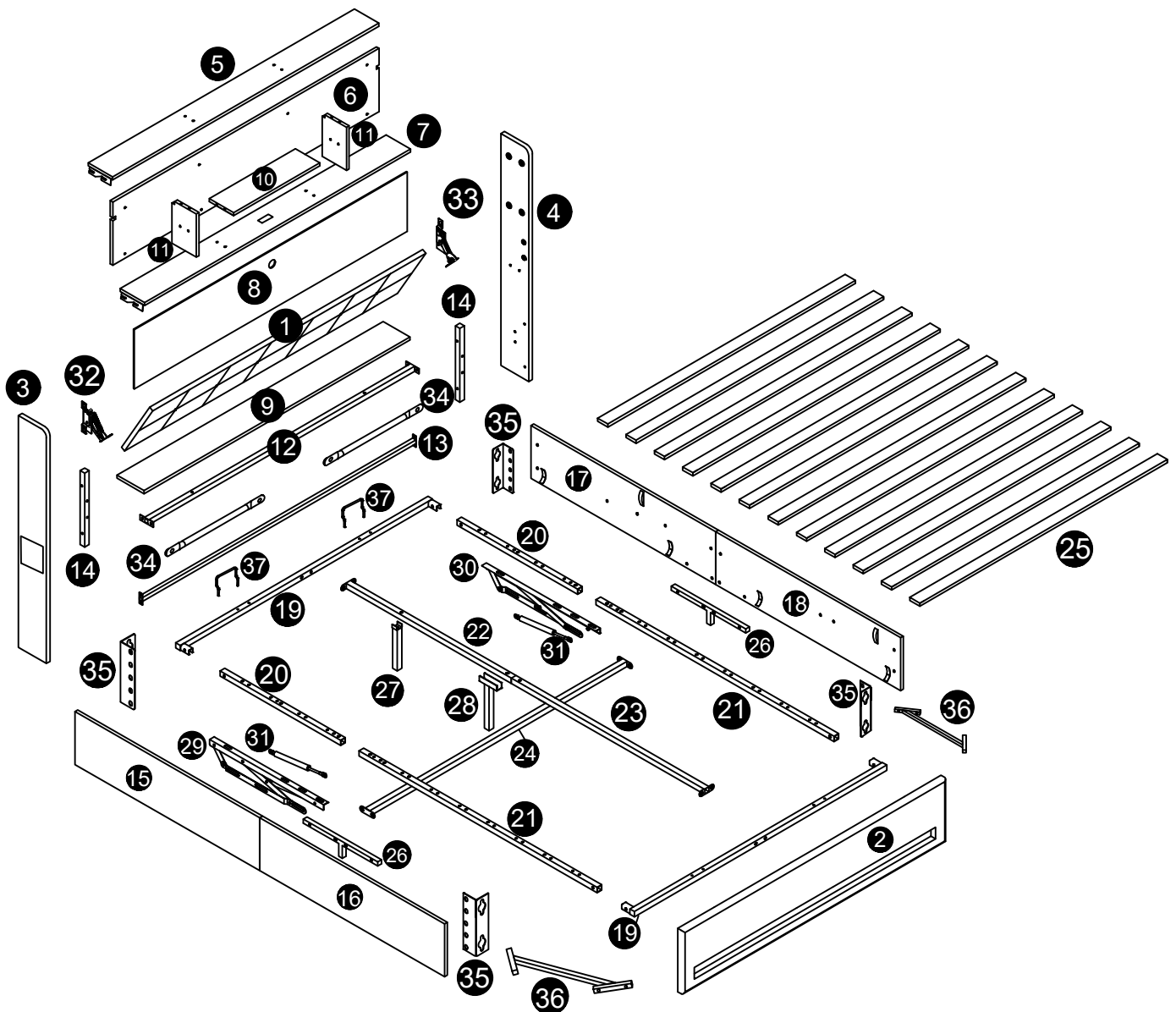

UK:Before starting the assembly you must read the whole manual and follow the instructions

DE:Lesen Sie vor der Montage die Anleitung aufmerksam durch und befolgen Sie streng die Anleitung.

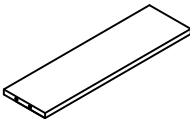
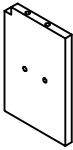
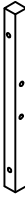
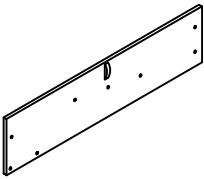
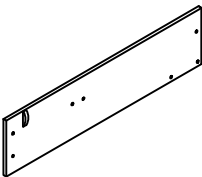
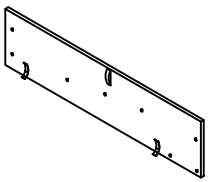
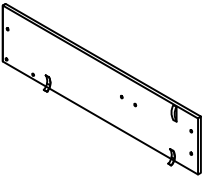
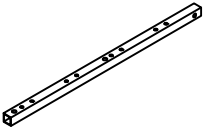
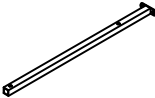
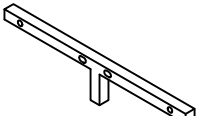

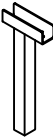
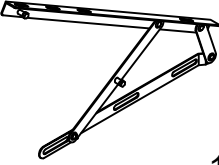
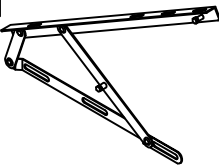
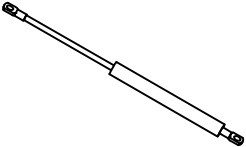
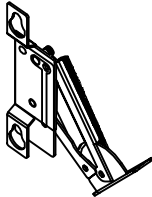

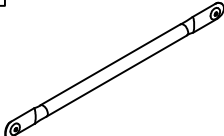
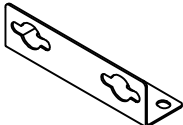
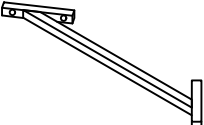
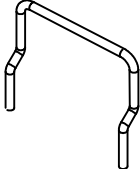
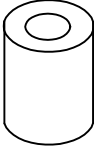
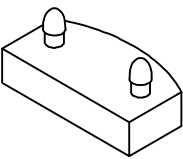
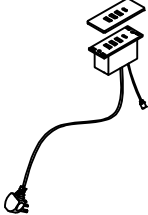
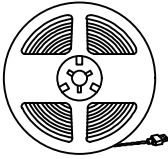
FR:Veuillez lire attentivement le manuel et puis bien suivre les instructions pour l'assemblage





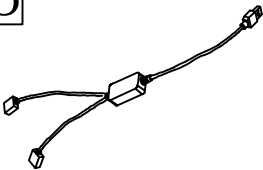
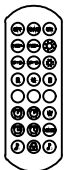
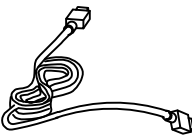

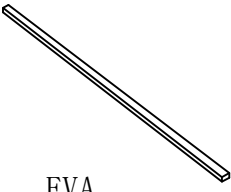



# Part list Box-A

3		1pc	4		1pc	10		1pc	11		2pcs
14		2pcs	15		1pc	16		1pc	17		1pc
18		1pc	20		2pcs	22		1pc	26		2pcs
27		1pc	28		1pc	29		1pc	30		1pc
31		2pcs	32		1pc	33		1pc	34		2pcs
35		4pcs	36		2pcs	37		2pcs	38		6pcs
39		26pcs	40		1pc	41		1pc	42		1pc

# Part list Box-A

<p>43</p>  <p>1pc</p>	<p>44</p>  <p>1pc</p>	<p>45</p>  <p>1pc</p>	<p>46</p>  <p>1pc</p>
<p>47</p>  <p>EVA 1pc</p>	<p>48</p>  <p>EVA 7pcs</p>		

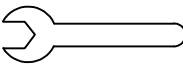
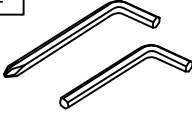
# Hardware list Box-A

<p>A</p>  <p>M8*55mm 4pcs</p>	<p>B</p>  <p>M8*35mm 45pcs</p>	<p>C</p>  <p>M8*20mm 17pcs</p>	<p>D</p>  <p>M8*15mm 22pcs</p>	<p>E</p>  <p>M5*30mm 22PCS</p>
<p>F</p>  <p>M4*12mm 3pcs</p>	<p>G</p>  <p>M8 18PCS</p>	<p>H</p>  <p>M8 1PC</p>	<p>I</p>  <p>M5*65MM 1pc</p>	<p>J</p>  <p>M3*65MM 1pc</p>

# Part list Box -B

<p>1</p> <p>1pc</p>	<p>2</p> <p>1pc</p>	<p>5</p> <p>1pc</p>	<p>6</p> <p>1pc</p>
<p>7</p> <p>1pc</p>	<p>8</p> <p>1pc</p>	<p>9</p> <p>1pc</p>	<p>12</p> <p>1pc</p>
<p>13</p> <p>1pc</p>	<p>19</p> <p>2pcs</p>	<p>21</p> <p>2pcs</p>	<p>23</p> <p>1pc</p>
<p>24</p> <p>1PC</p>	<p>25</p> <p>12pcs</p>		

## Step1

F		M4x12mm	2pcs
I		M5*65	1pc

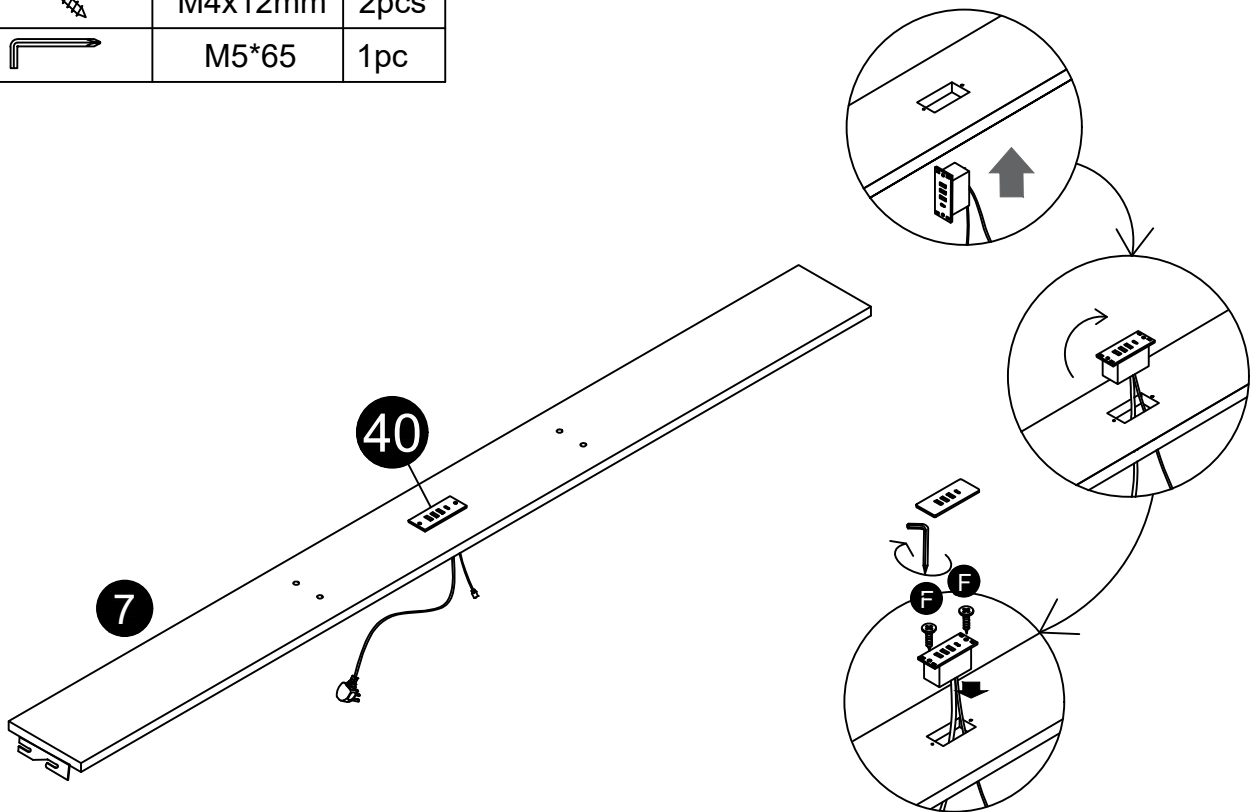

## Step2

I



M5\*65

1pc

UK:Note: Velcro is facing backwards.

FR:Côté avec velcro vers le haut

DE:Klettverschluss nach oben

41



UK:Unfold the light strip and secure it

FR:Dépliez la bande lumineuse et fixez-la

DE:Entfalten Sie den Lichtstreifen und sichern Sie ihn

Hole up

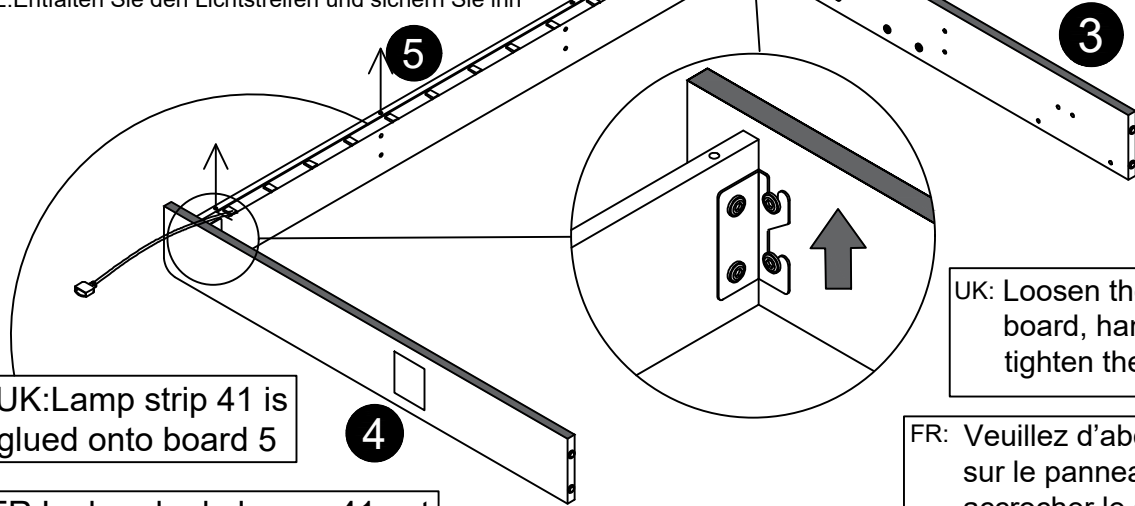

UK:Lamp strip 41 is glued onto board 5

FR:La bande de lampe 41 est collée sur la carte 5

DE:Lampenstreifen 41 wird auf die Platte 5 geklebt

UK: Loosen the screws on the side board, hang the brackets and tighten the screws.

FR: Veuillez d'abord desserrer les vis sur le panneau latéral, pour accrocher le support, et puis bien serrer les vis

DE: Lösen Sie Schrauben auf den Seitenplatten, hängen Sie die Halterung ein und ziehen Sie die Schrauben wieder fest

## Step3

I



M5\*65

1pc

Hole up

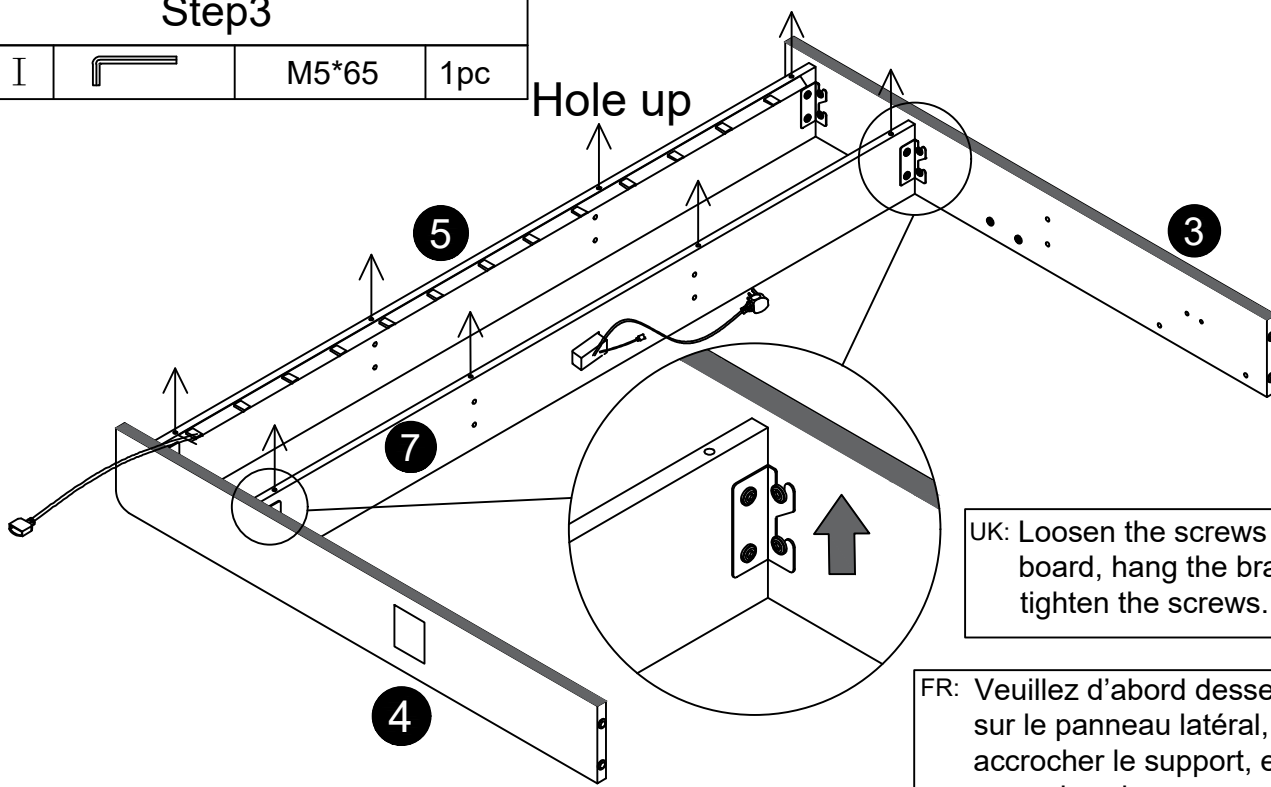



UK: Loosen the screws on the side board, hang the brackets and tighten the screws.

FR: Veuillez d'abord desserrer les vis sur le panneau latéral, pour accrocher le support, et puis bien serrer les vis

DE: Lösen Sie Schrauben auf den Seitenplatten, hängen Sie die Halterung ein und ziehen Sie die Schrauben wieder fest

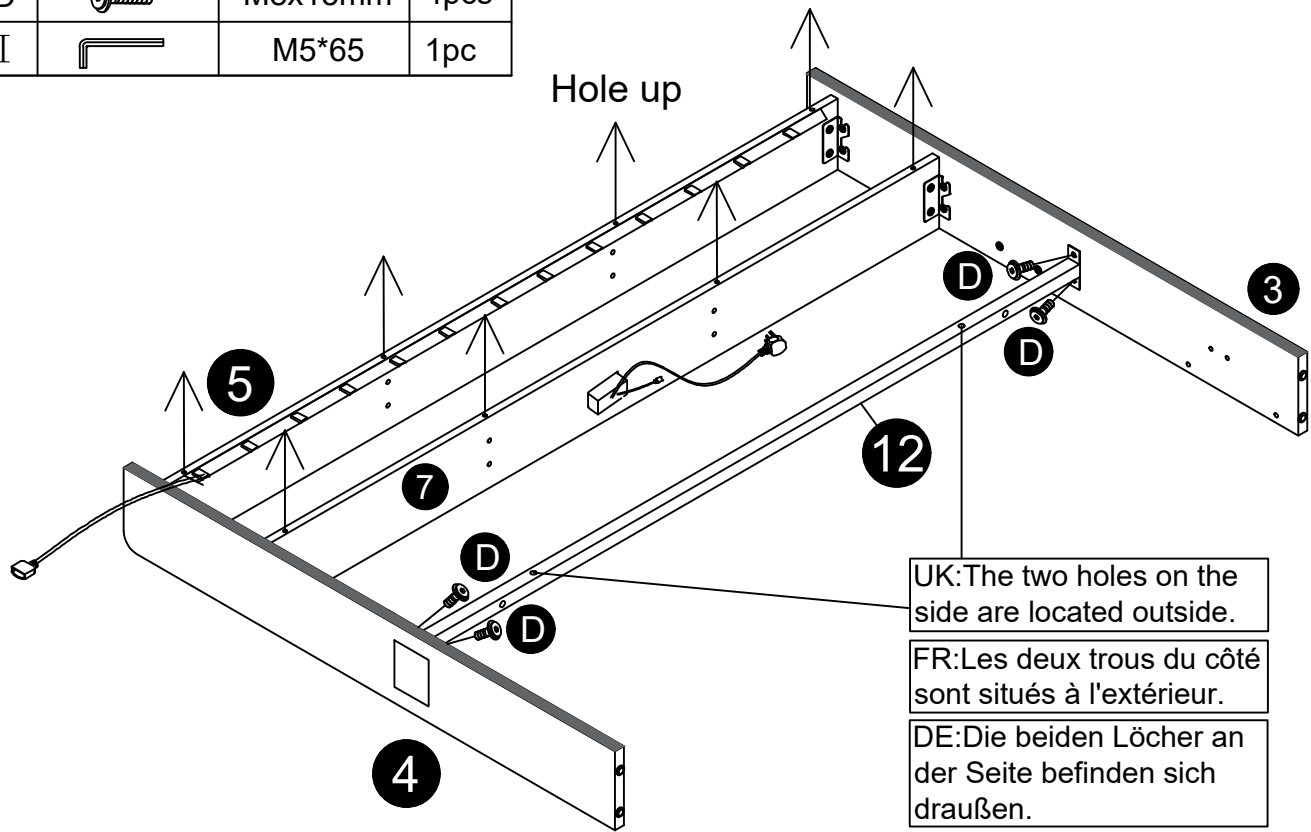

### Step4

D		M8x15mm	4pcs
I		M5*65	1pc



UK: The two holes on the side are located outside.  
 FR: Les deux trous du côté sont situés à l'extérieur.  
 DE: Die beiden Löcher an der Seite befinden sich draußen.



### Step5

B		M8x35mm	2pcs
I		M5*65	1pc

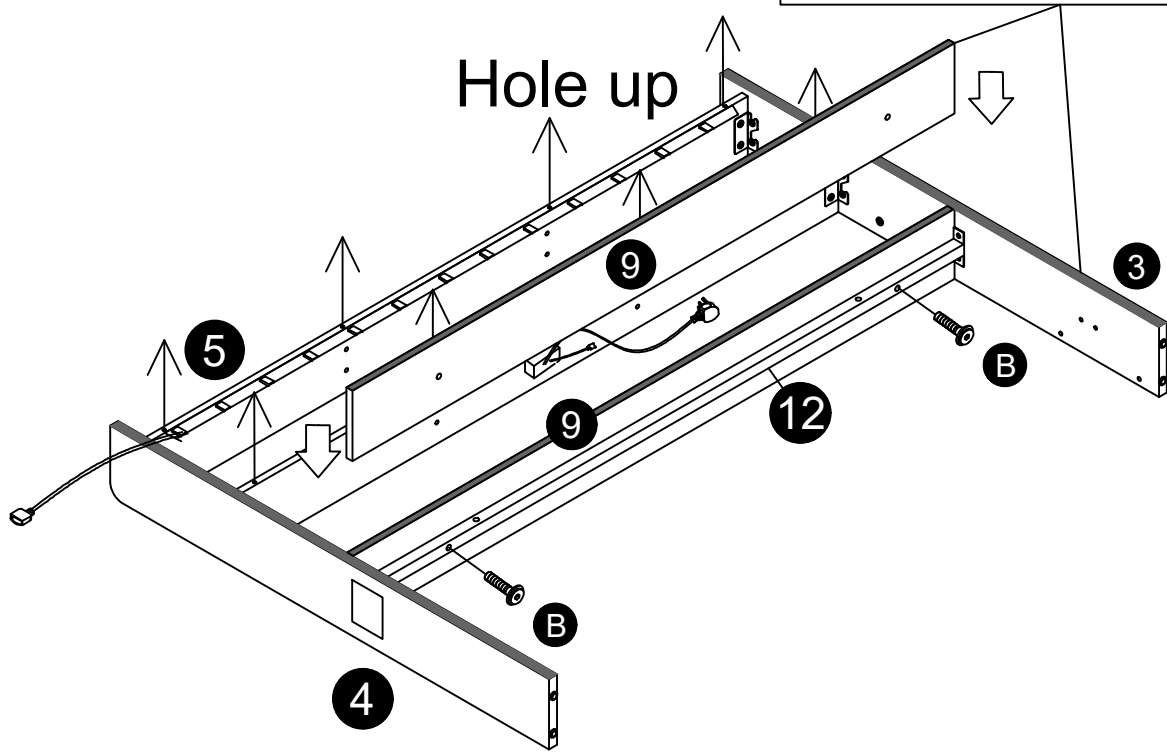
UK: Note: Velcro is facing backwards.  
 FR: Côté avec velcro vers le haut  
 DE: Klettverschluss nach oben



### Step6

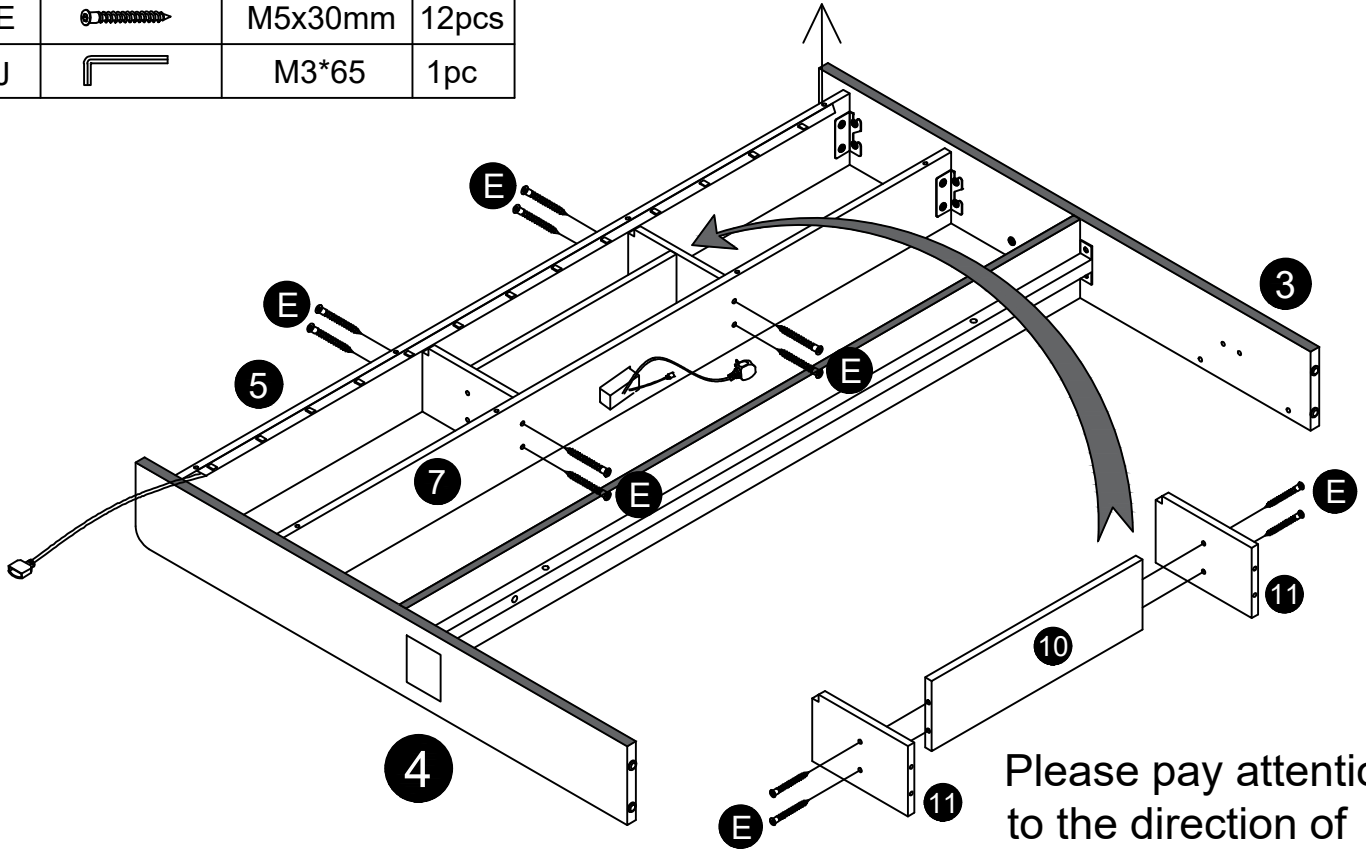

E		M5x30mm	12pcs
J		M3*65	1pc

Hole up



Please pay attention to the direction of component (10).

### Step7

E		M5x30mm	8pcs
J		M3*65	1pc

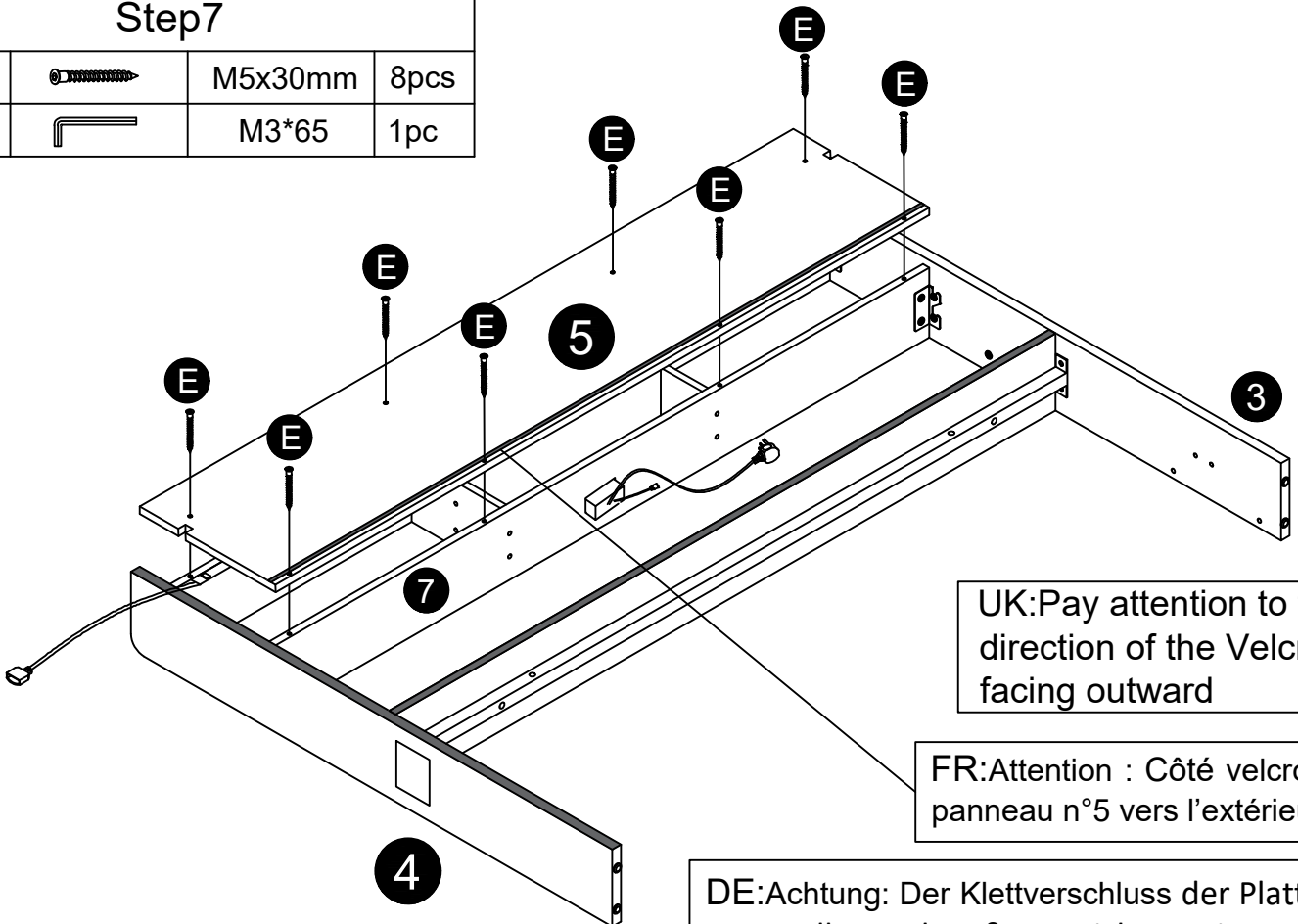



UK: Pay attention to the direction of the Velcro facing outward

FR: Attention : Côté velcro du panneau n°5 vers l'extérieur



DE: Achtung: Der Klettverschluss der Platte Nr. 5 sollte nach außen gerichtet sein

### Step8

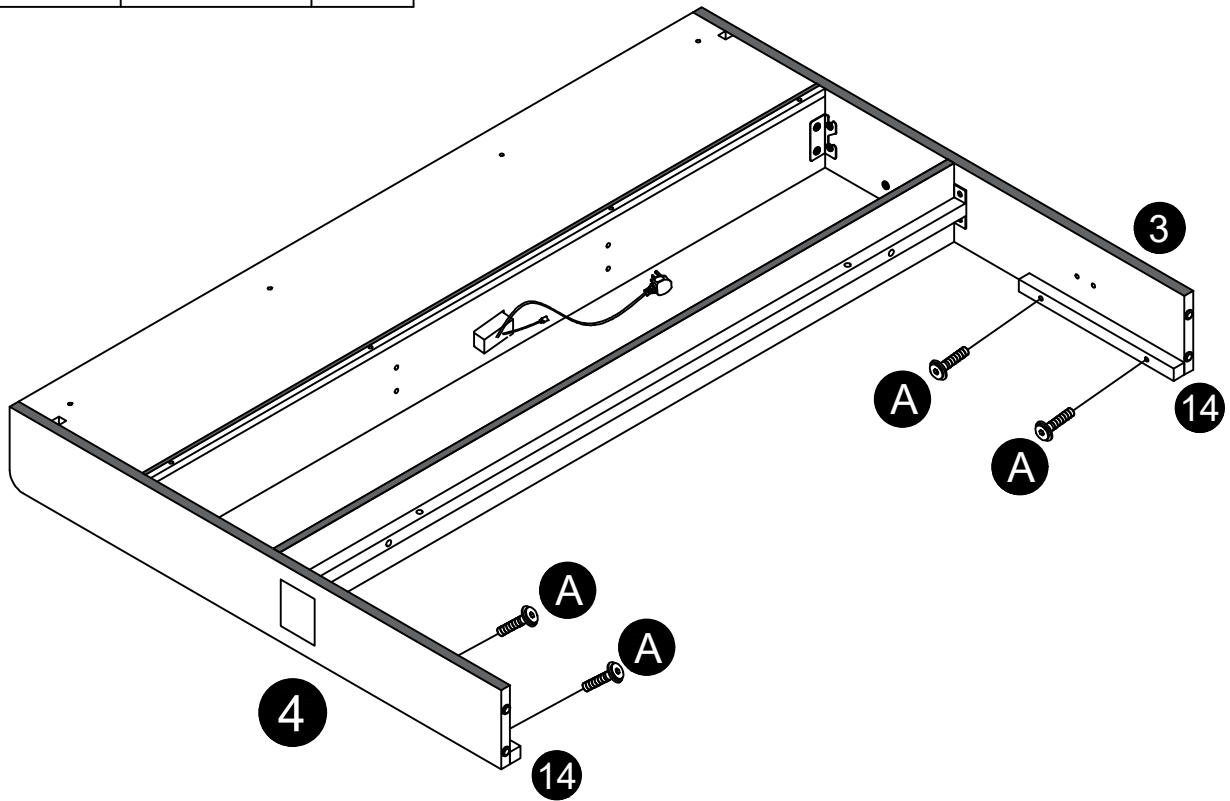
A		M8x55mm	4pcs
I		M5*65	1pc



### Step9

D		M8x15mm	4pcs
I		M5*65	1pc

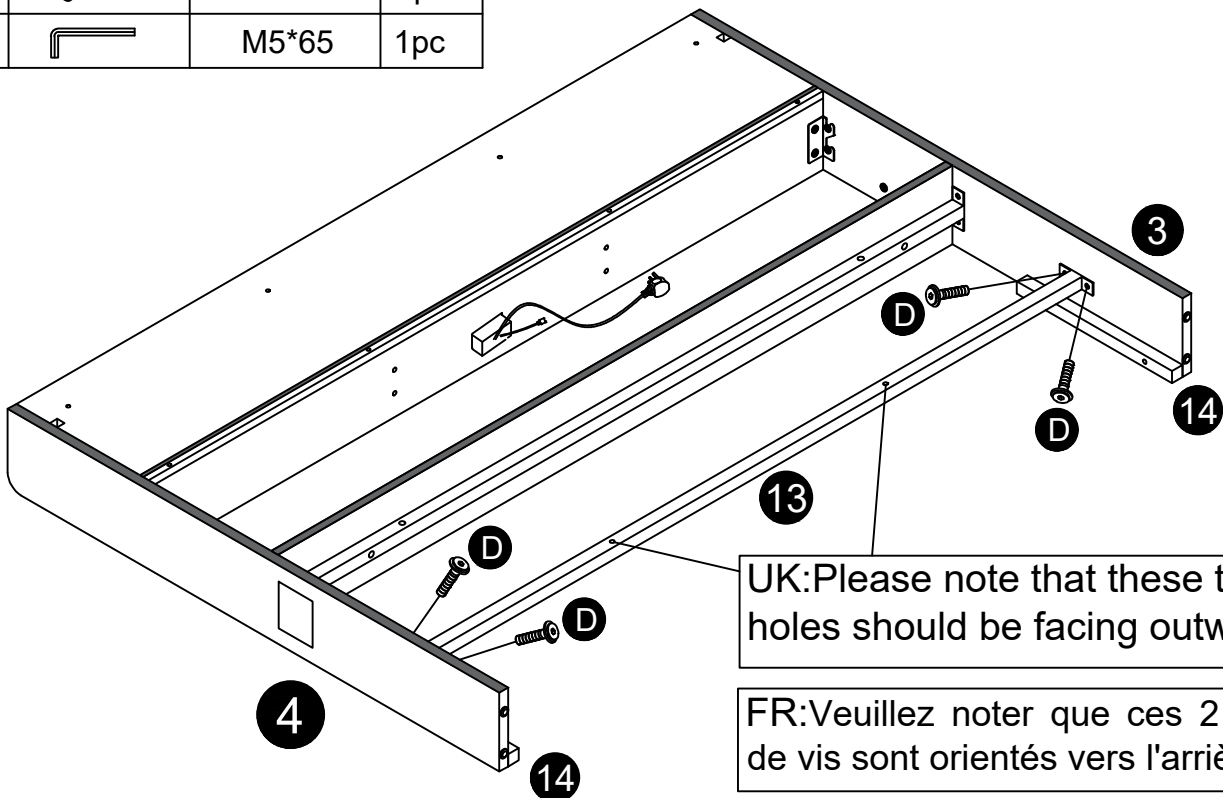



UK: Please note that these two holes should be facing outward

FR: Veuillez noter que ces 2 trous de vis sont orientés vers l'arrière

DE: Achtung: Die beiden Löcher nach hinten

## Step10

C		M8x20mm	4pcs
I		M5*65	1pc

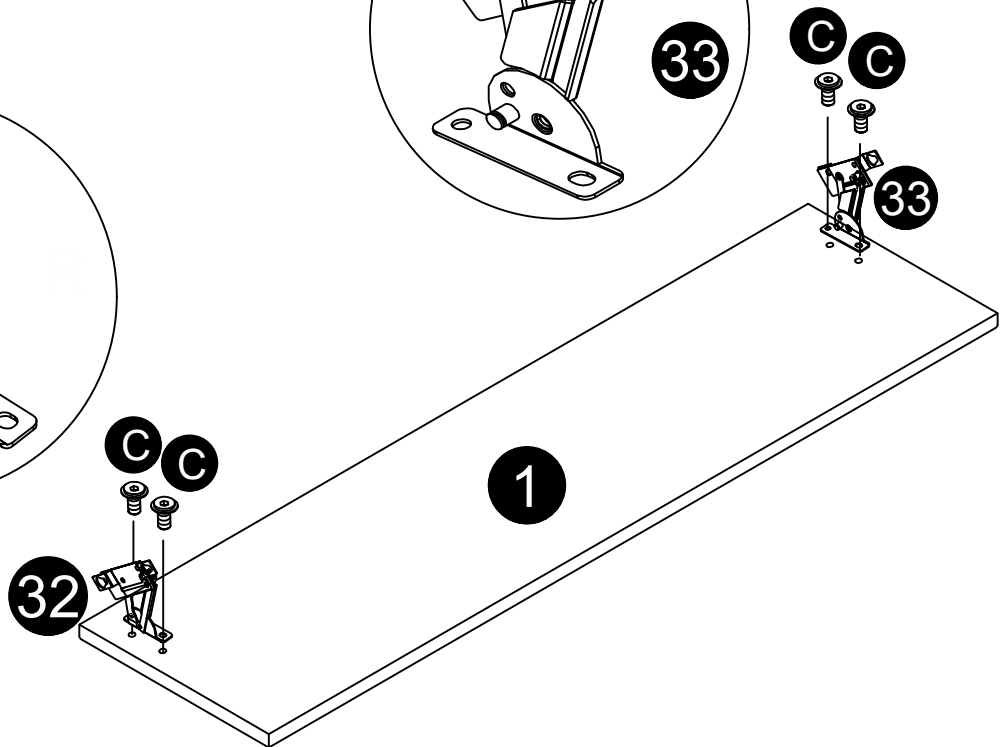
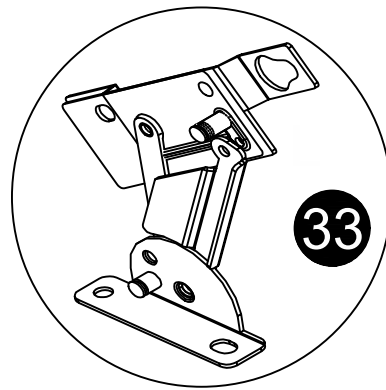
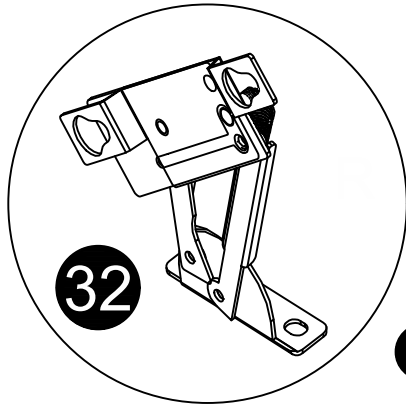

## Step11

I		M5*65	1pc
---	---	-------	-----



UK: RECOMMEND 2 OR MORE ADULTS FOR QUICKER ASSEMBLY

FR: RECOMMANDER 2 ou plus d'adultes pour un assemblage plus rapide

DE: 2 oder mehr Erwachsene für eine schnellere Versammlung empfehlen

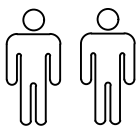

2PERS

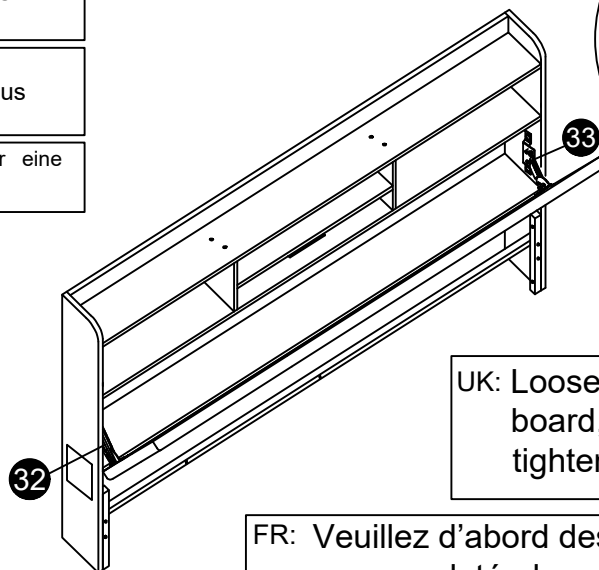
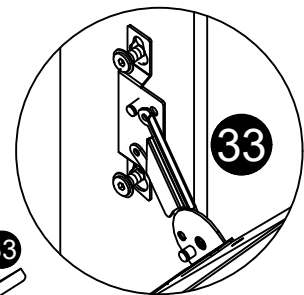

UK: Loosen the screws on the side board, hang the brackets and tighten the screws.

FR: Veuillez d'abord desserrer les vis sur le panneau latéral, pour accrocher le support, et puis bien serrer les vis

DE: Lösen Sie Schrauben auf den Seitenplatten, hängen Sie die Halterung ein und ziehen Sie die Schrauben wieder fest

## Step12

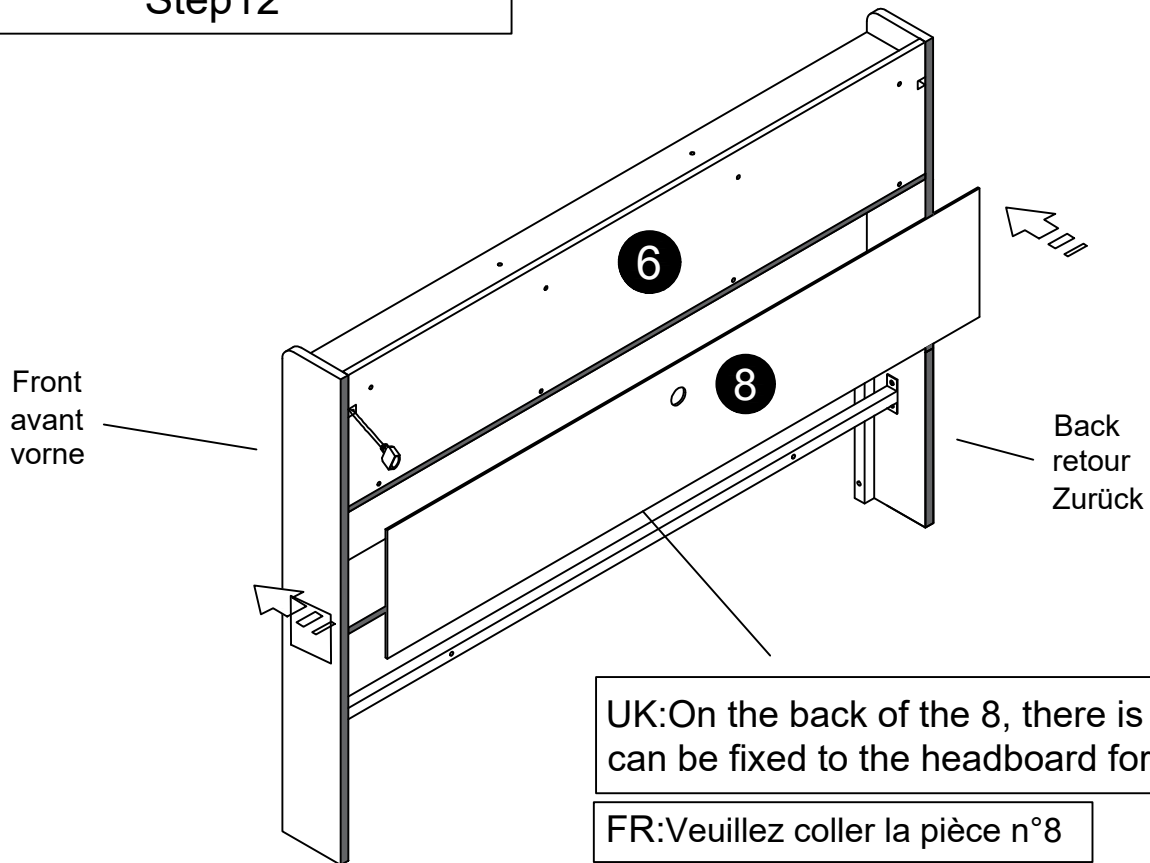



UK: On the back of the 8, there is a Velcro that can be fixed to the headboard for adhesion

FR: Veuillez coller la pièce n°8



DE: Kleben Sie das Brett Nr. 8 auf

## Step13

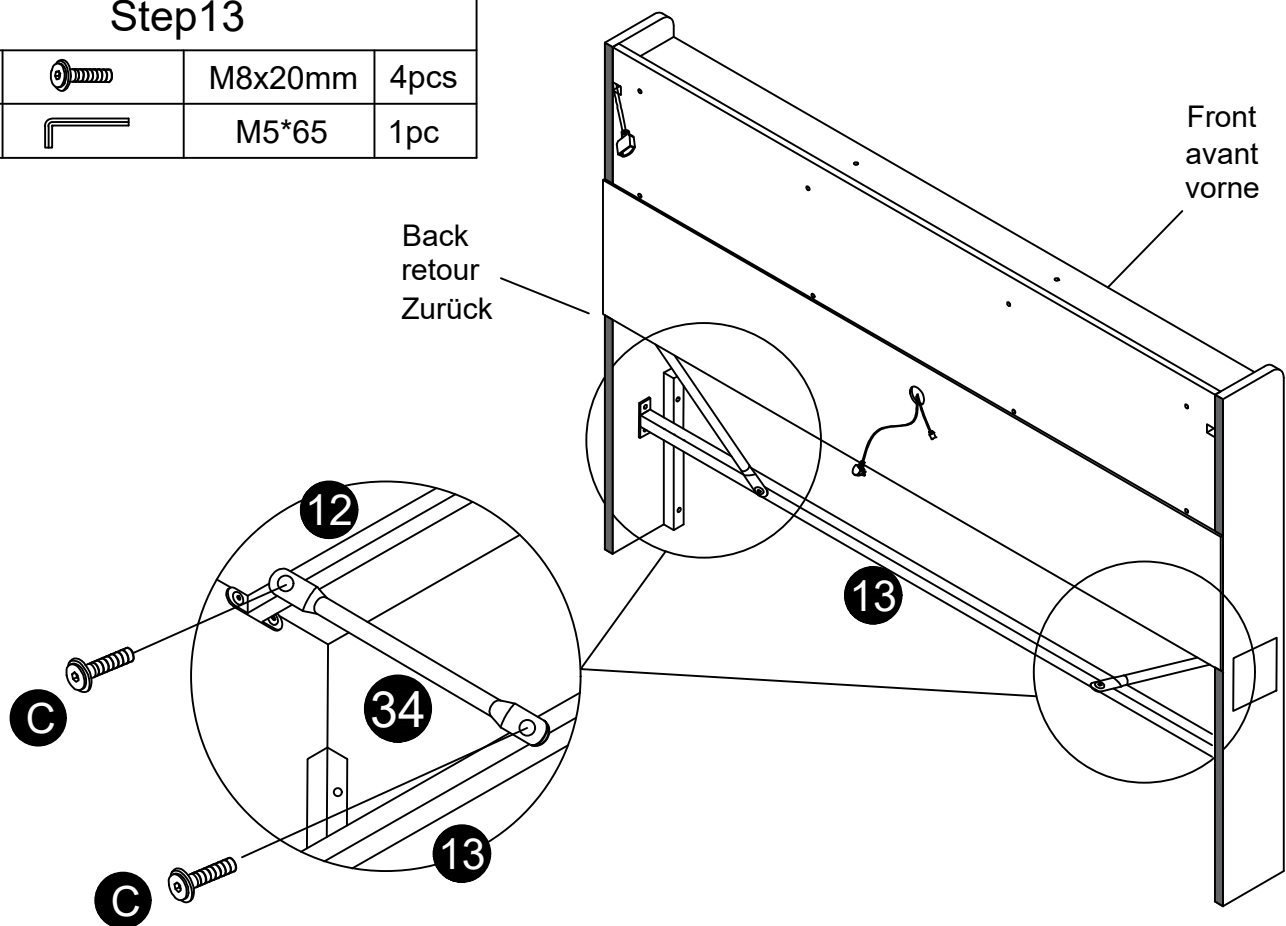
C		M8x20mm	4pcs
I		M5*65	1pc



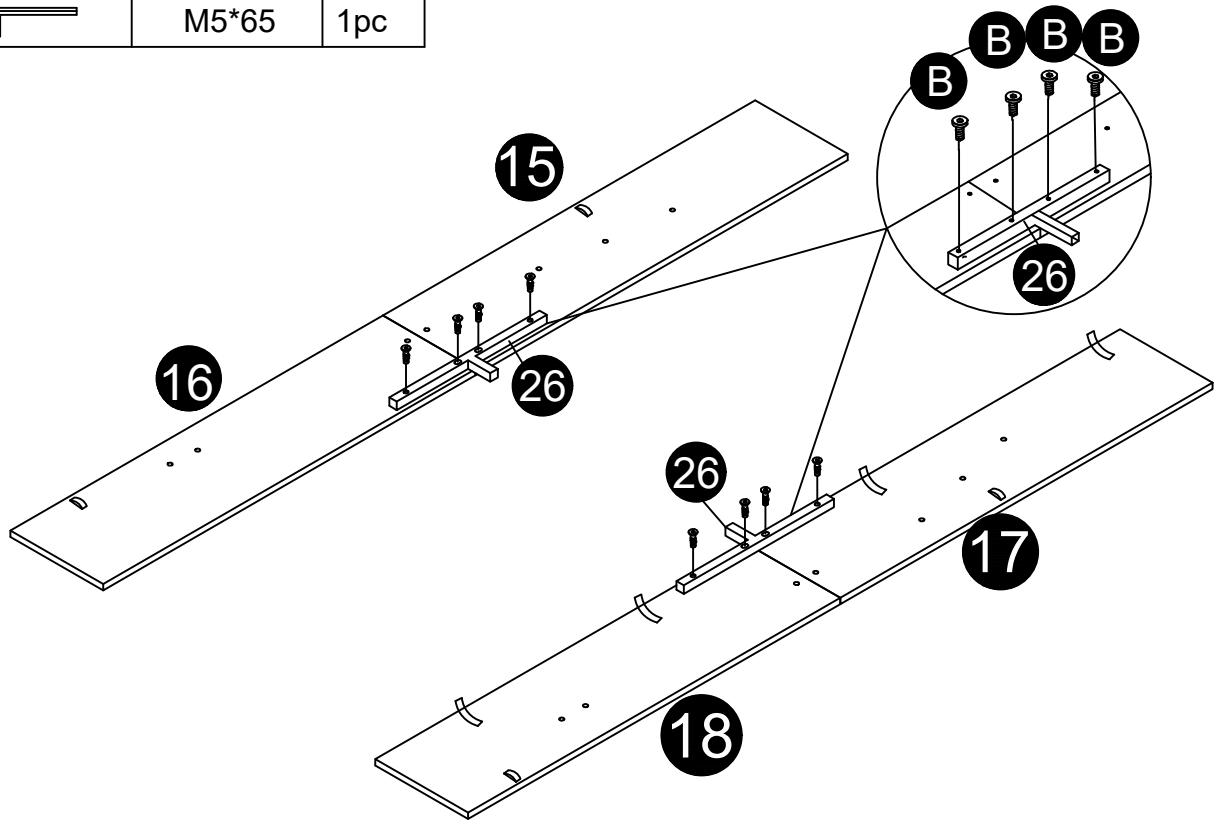

### Step14

B		M8x35mm	8pcs
I		M5*65	1pc



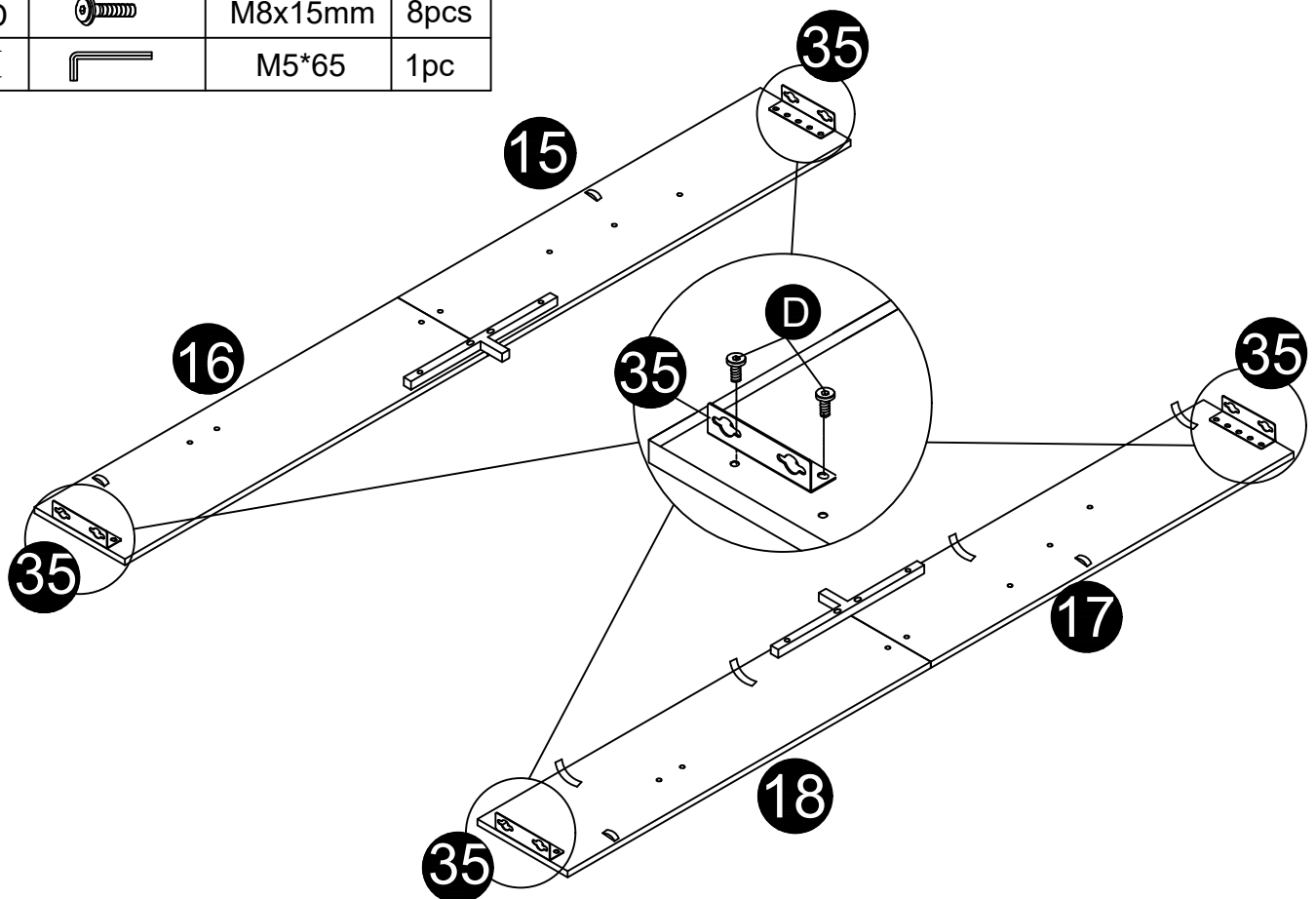

### Step15

D		M8x15mm	8pcs
I		M5*65	1pc



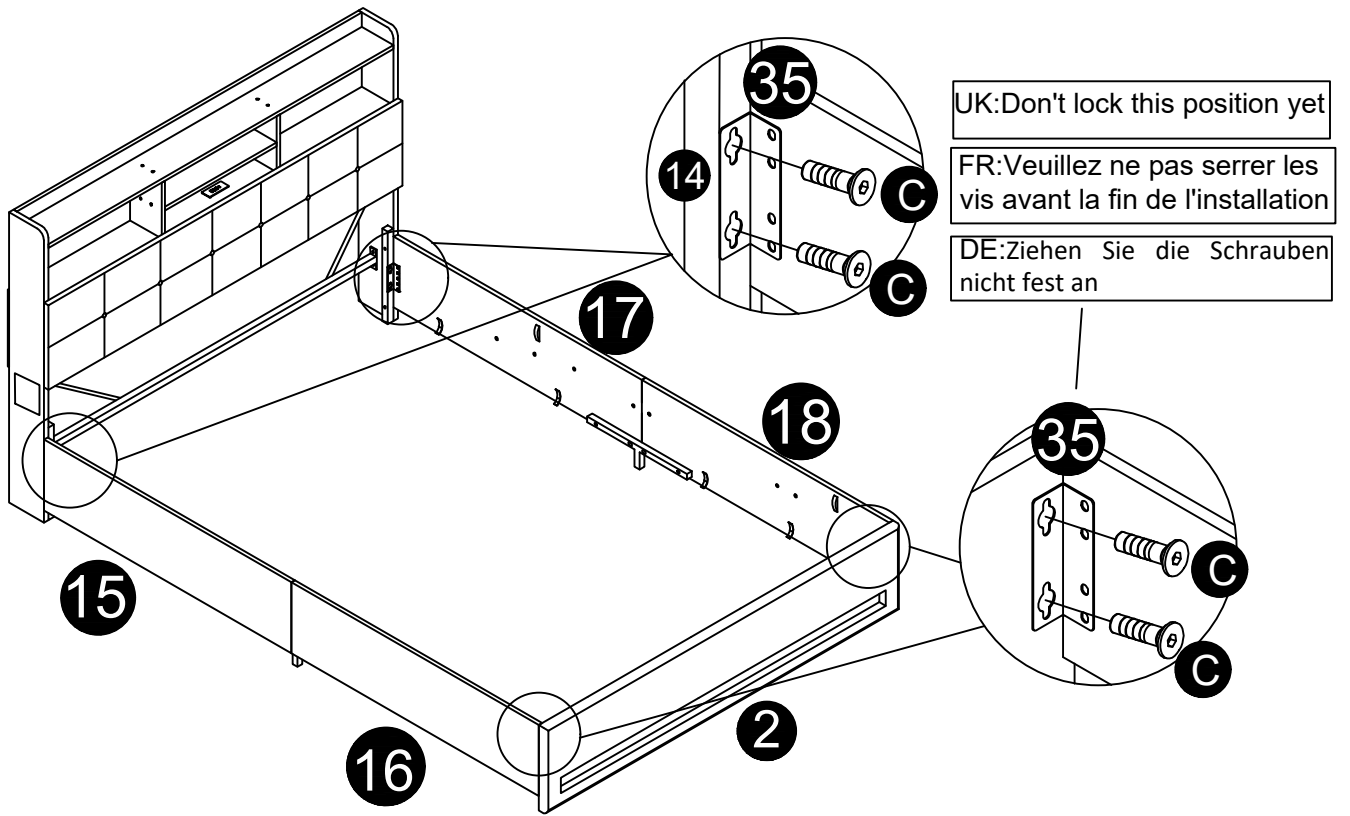

### Step16

C		M8x20mm	8pcs
I		M5*65	1pc



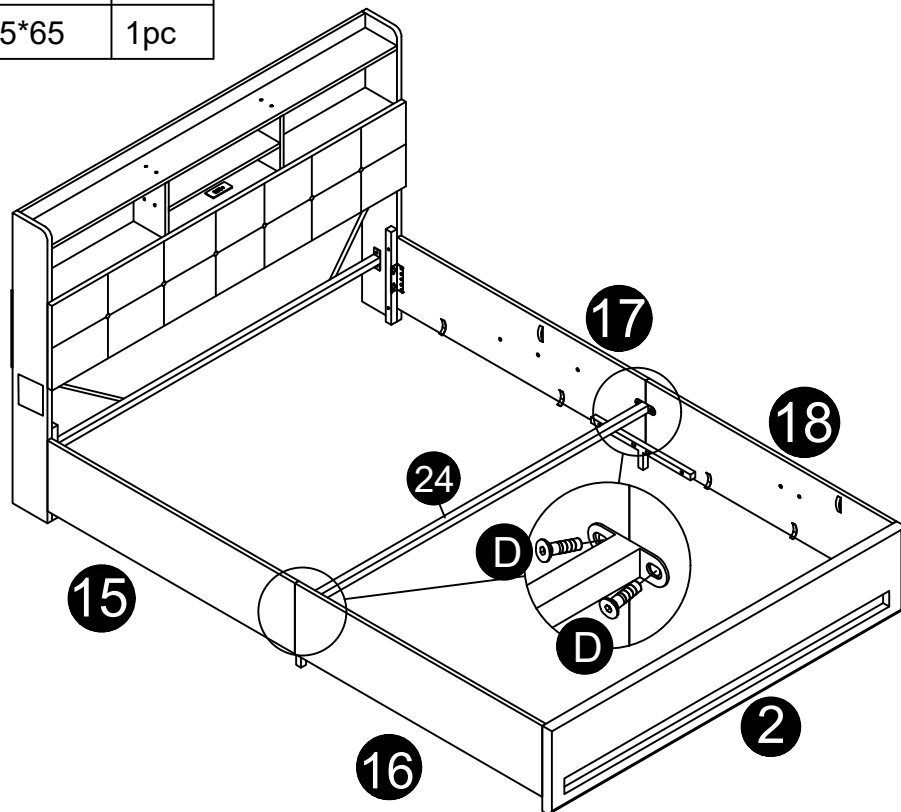

### Step17

D		M8x15mm	4pcs
I		M5*65	1pc



### Step18

B		M8x35mm	8pcs
I		M5*65	1pc



UK: Wait until the 36 diagonal braces are installed and locked together

FR: Veuillez aligner les trous avant de serrer les vis des pièces n°36

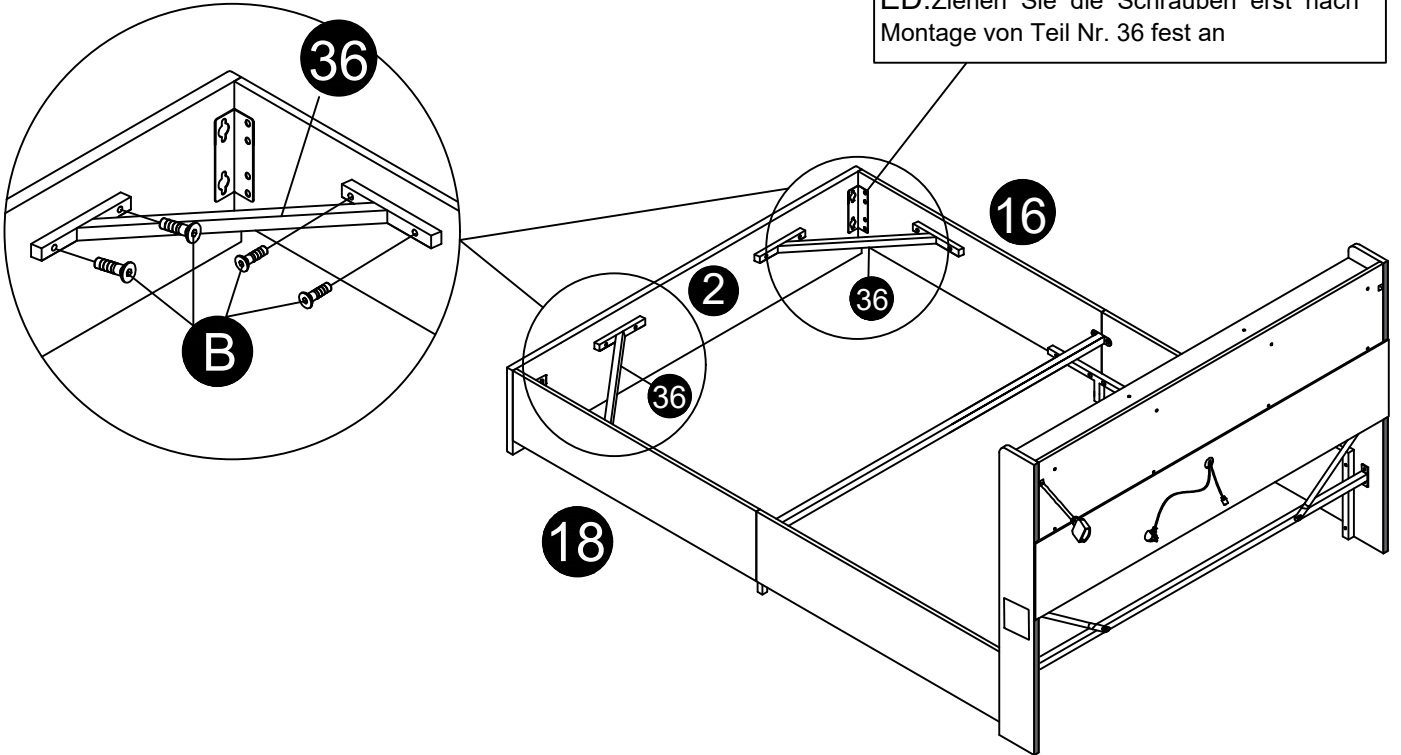
ED: Ziehen Sie die Schrauben erst nach Montage von Teil Nr. 36 fest an



### Step19



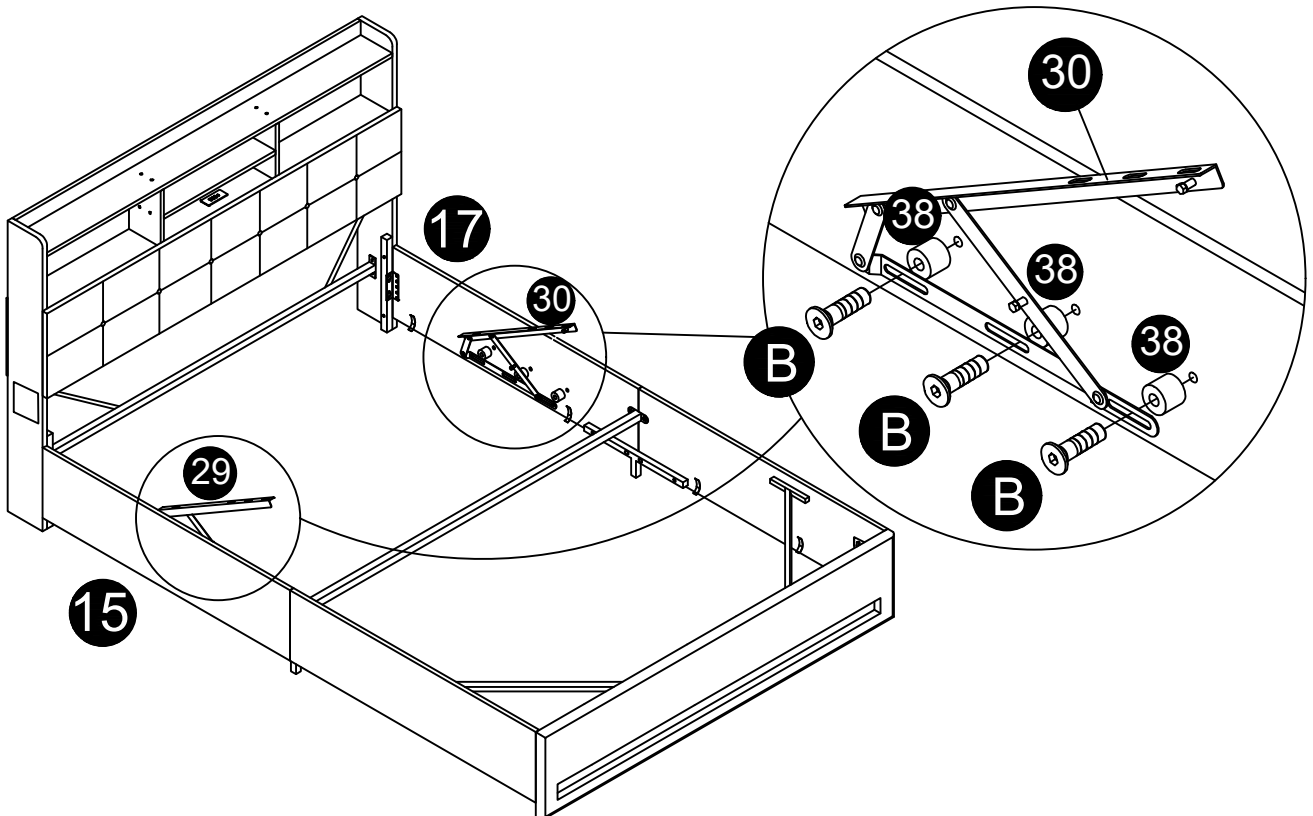

B		M8x35mm	6pcs
I		M5*65	1pc

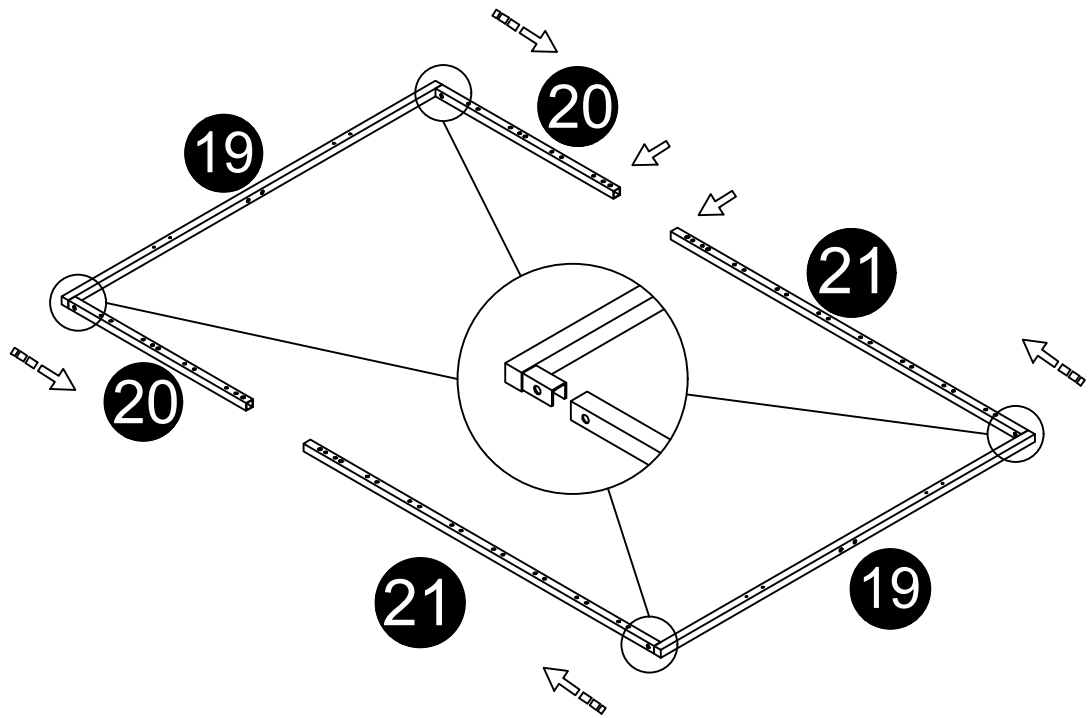

# Step20



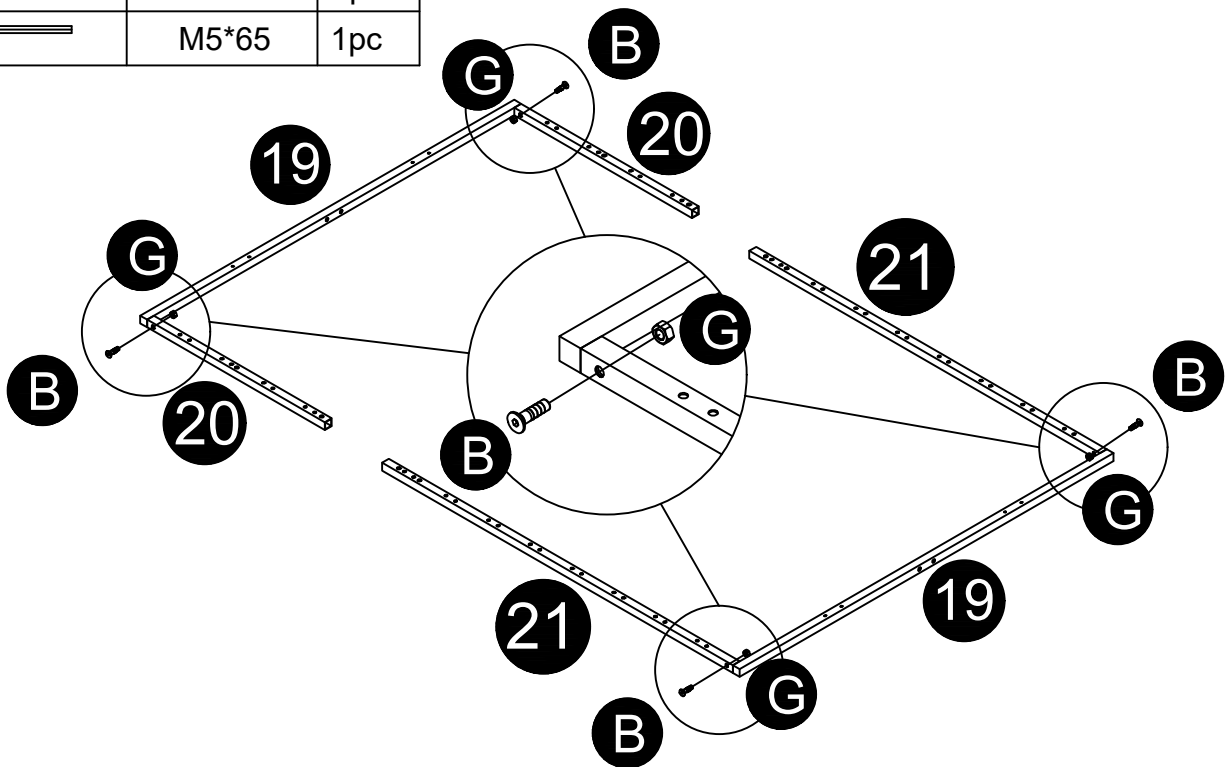

# Step21

B		M8x35mm	4pcs
G		M8	4pcs
H		M8	1pc
I		M5*65	1pc



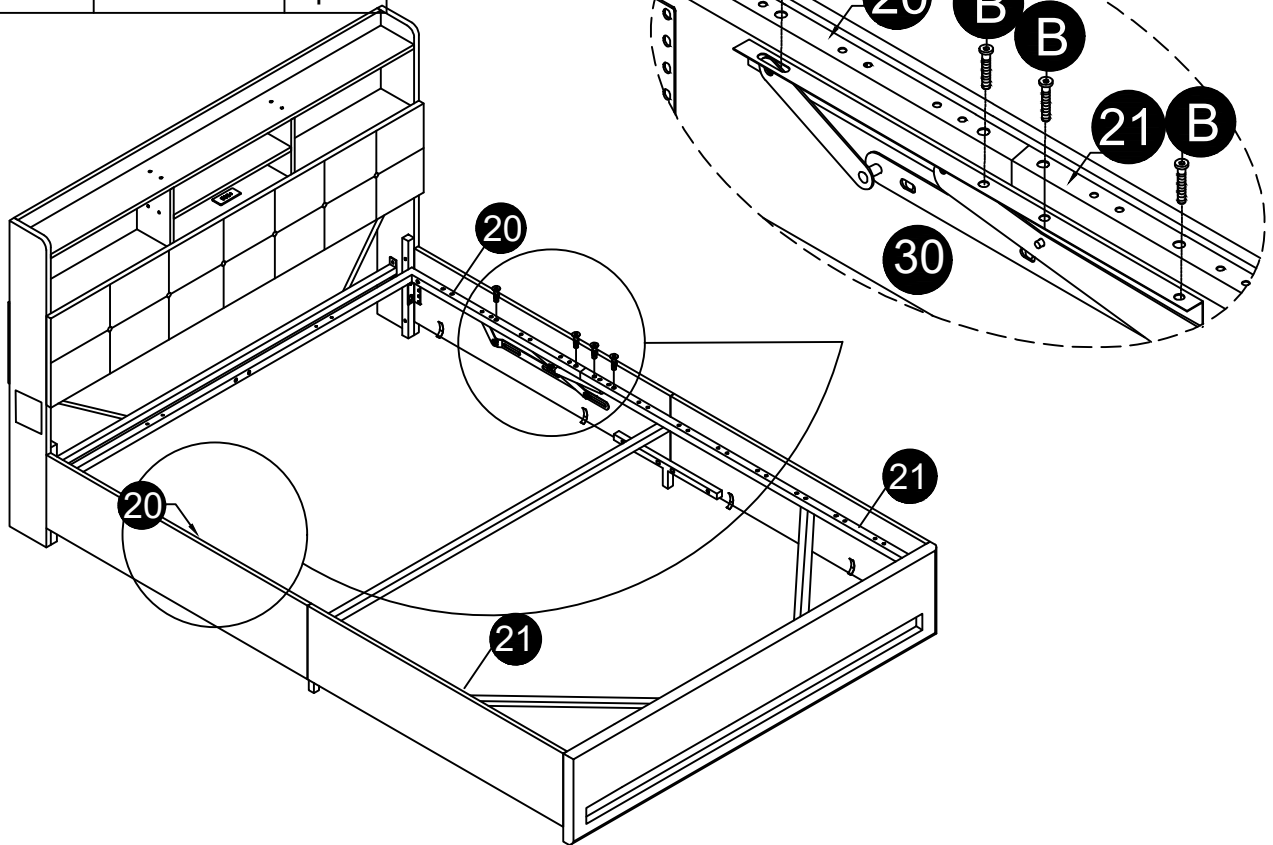

### Step22

B		M8x35mm	8pcs
I		M5*65	1pc



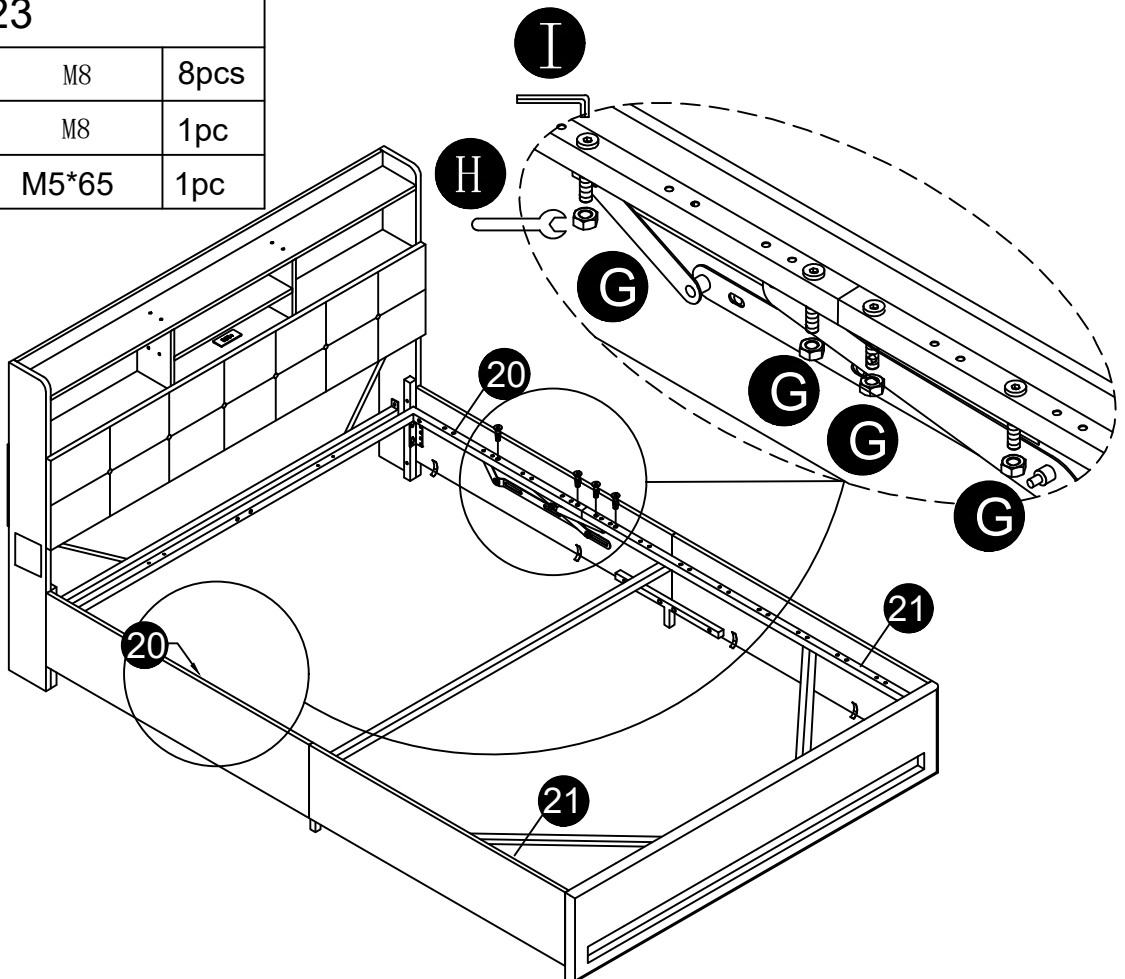

### Step23

G		M8	8pcs
H		M8	1pc
I		M5*65	1pc





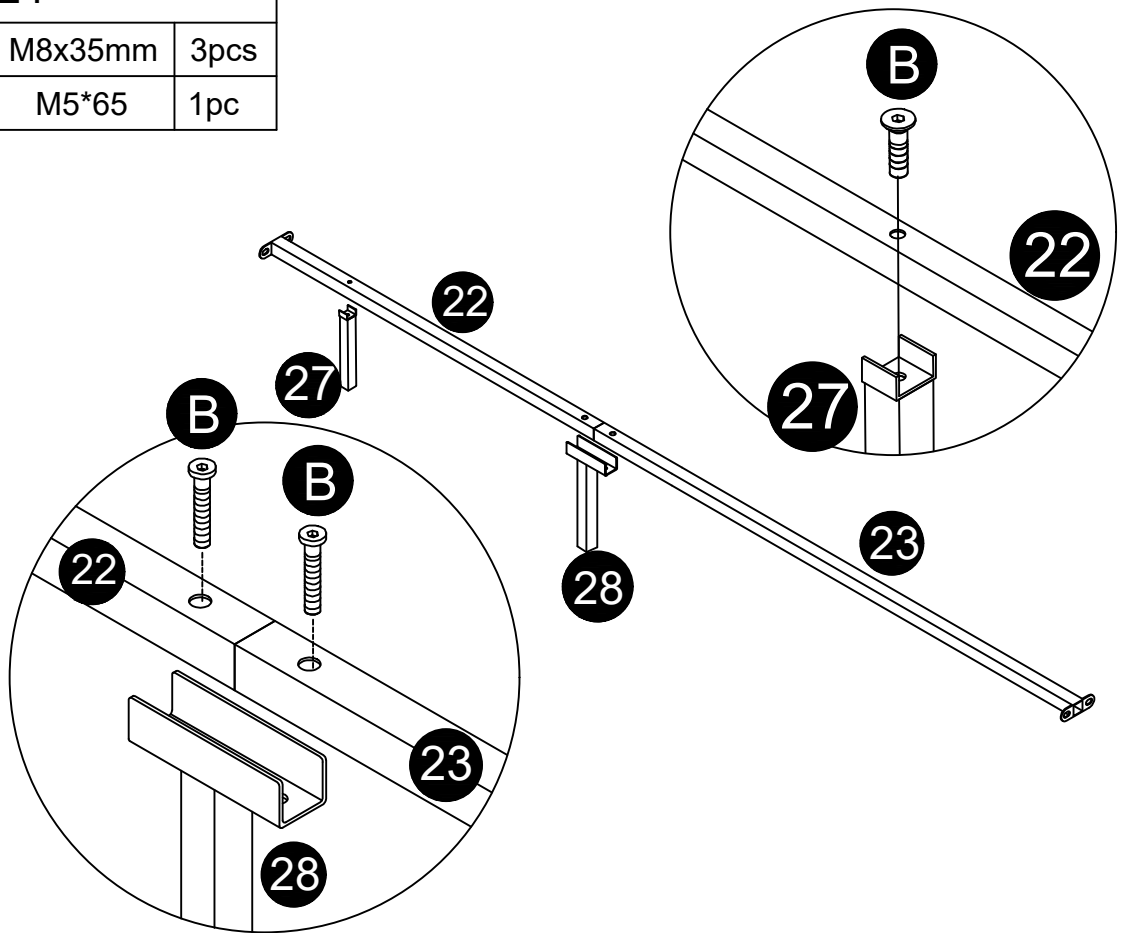

### Step24

B		M8x35mm	3pcs
I		M5*65	1pc



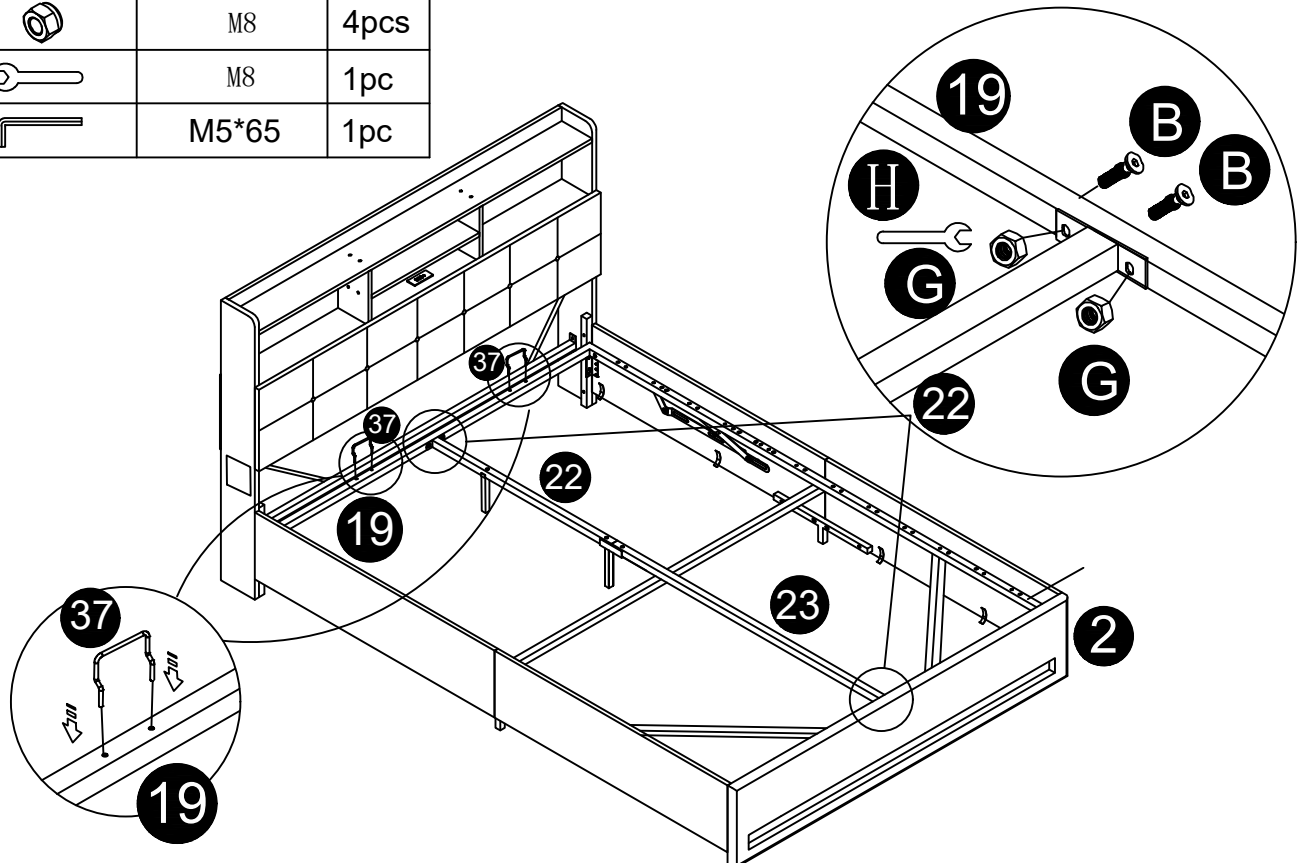

### Step25

B		M8x35mm	4pcs
G		M8	4pcs
H		M8	1pc
I		M5*65	1pc



## Step26

G		M8	4pcs
H		M8	1pc

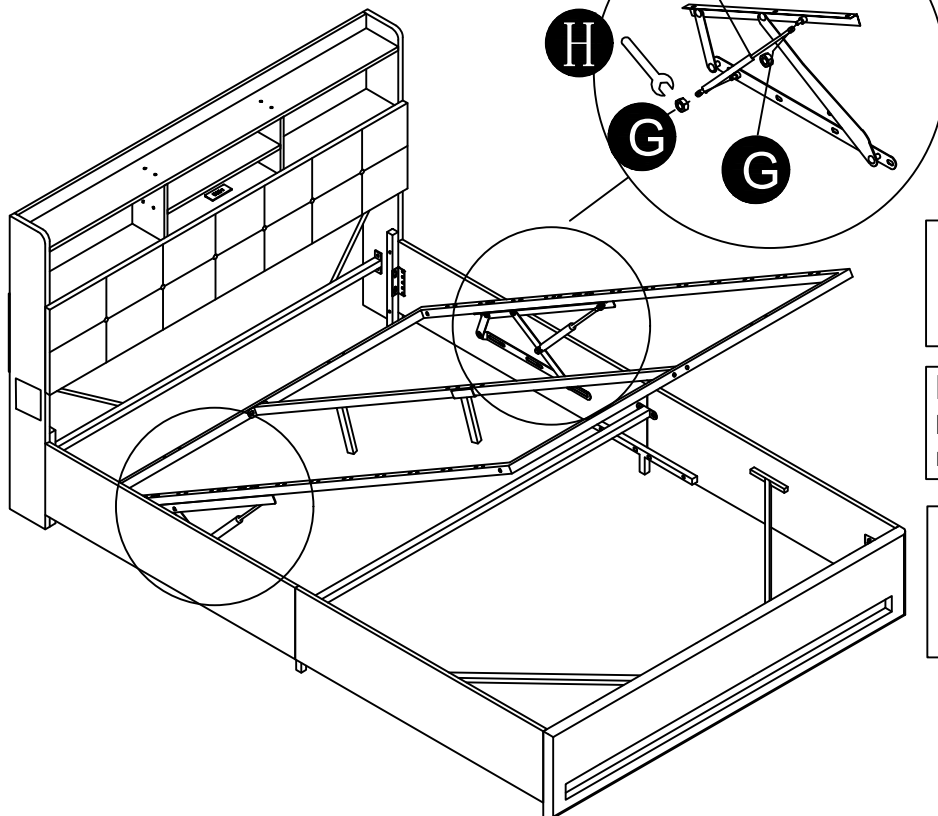

UK: Remove the nut first, hang the 31th, and then tighten the nut

FR: Veuillez d'abord desserrer les écrous pour installer la pièce n°31, puis resserrer les écrous

DE: Lösen Sie die Schraubenmutter, setzen Sie das Teil Nr. 31 ein und ziehen Sie dann sie wieder an

## Step27

Short

42

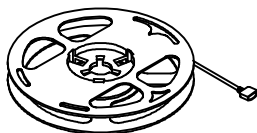

UK: Stick the light strip along the groove above

FR: Veuillez coller la bande LED le long de la rainure

DE: Kleben Sie den Lichtstreifen entlang der Nut auf

UK: The 42th light strip is inserted from the inside of the 2nd bed tail

FR: Veuillez insérer la bande LED n°42 par l'intérieur du pied de lit n°2

DE: Führen Sie den Lichtstreifen Nr.42 von der Innenseite des Kopfendes durch dieses Loch

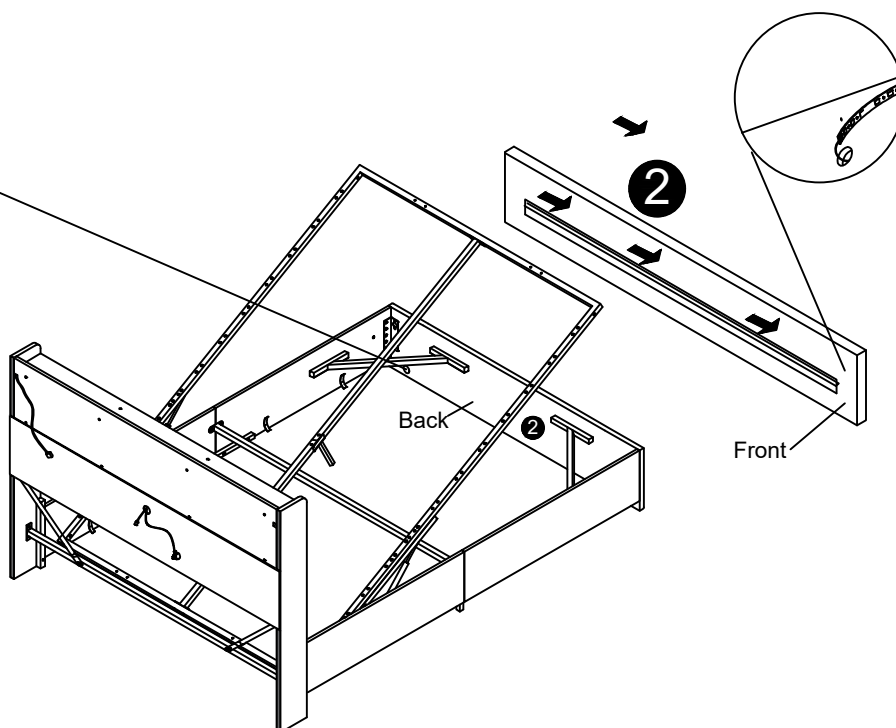

## Step28

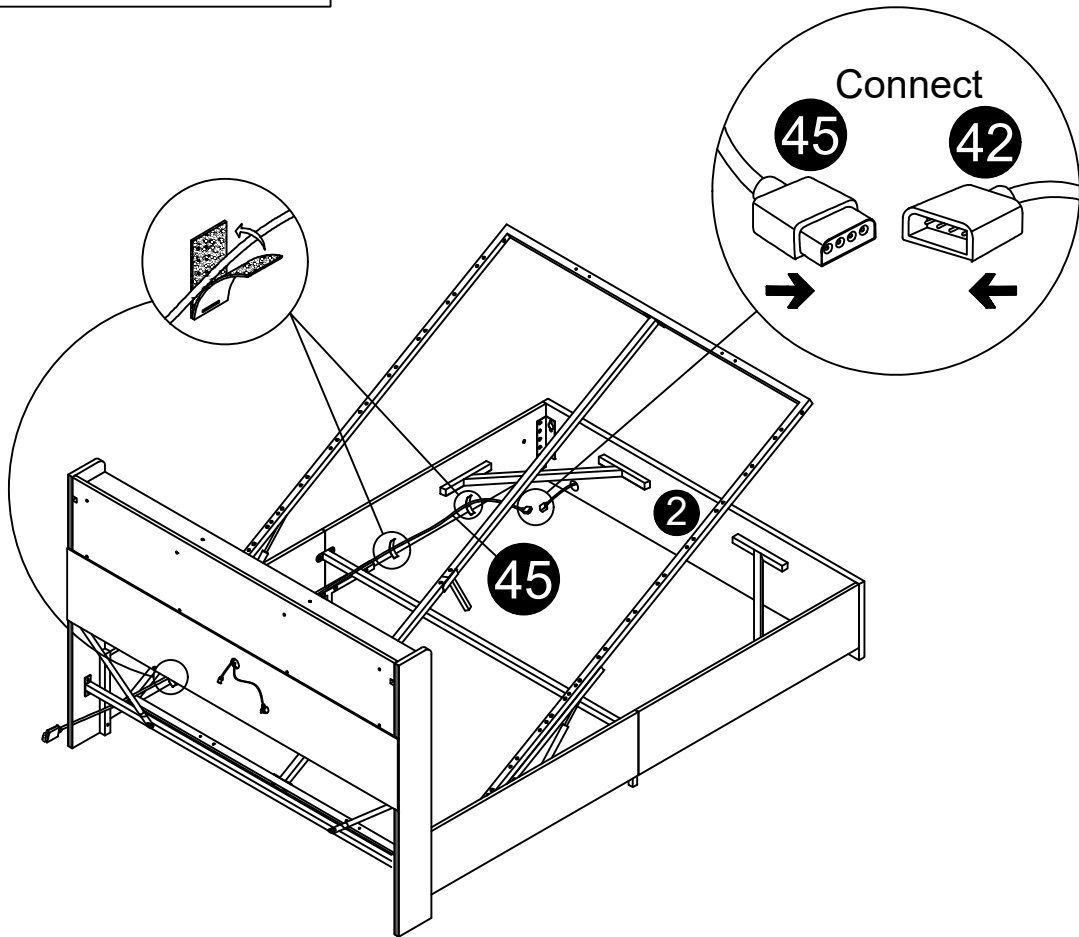

## Step29

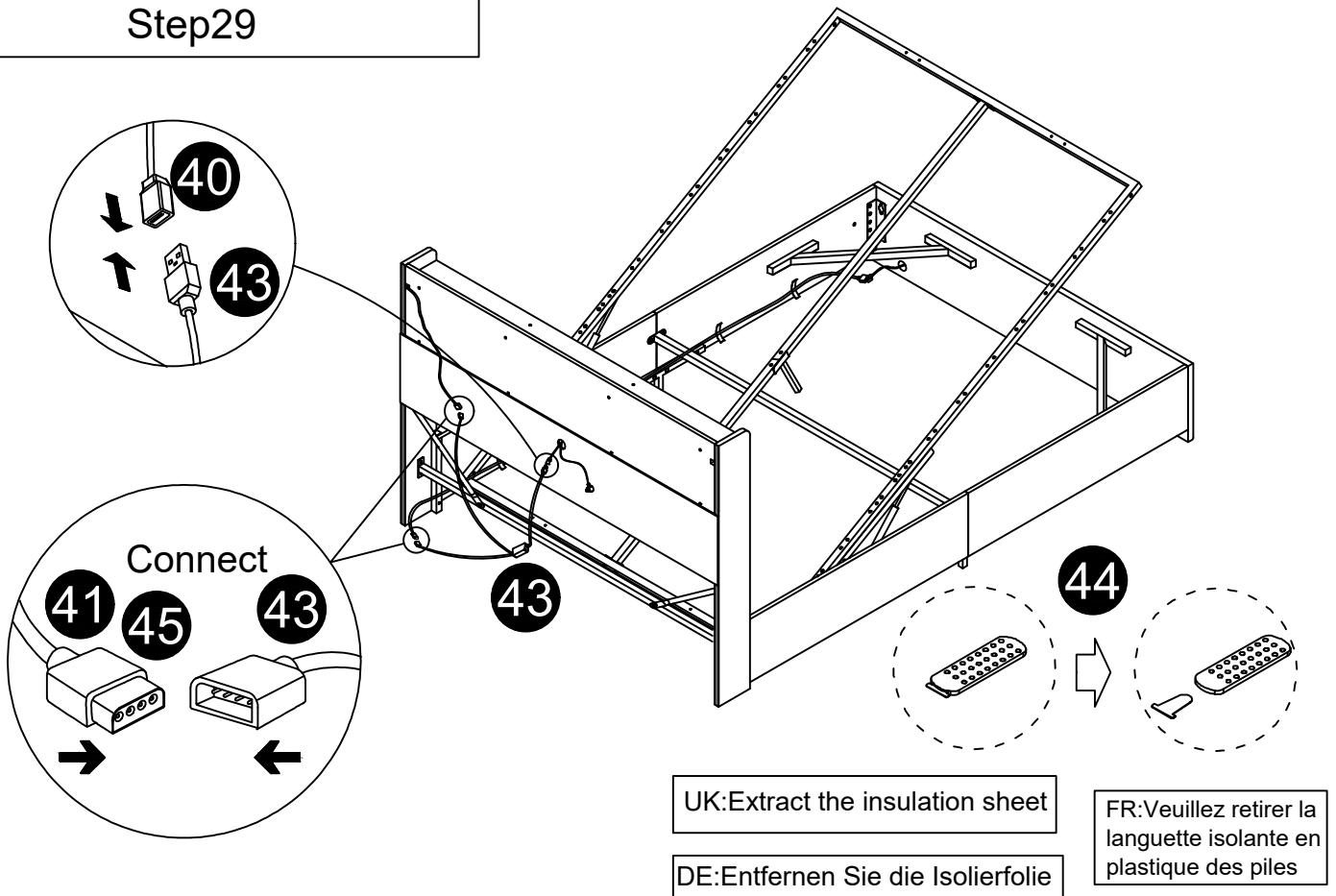

## Step30

UK: Paste the 47 # foam pad on the middle pipe

FR: Veuillez coller le coussin EVA anti-vibration n°47 sur le tube central

DE: Kleben Sie den Dämpferstreifen Nr. 47 auf die mittlere Stange

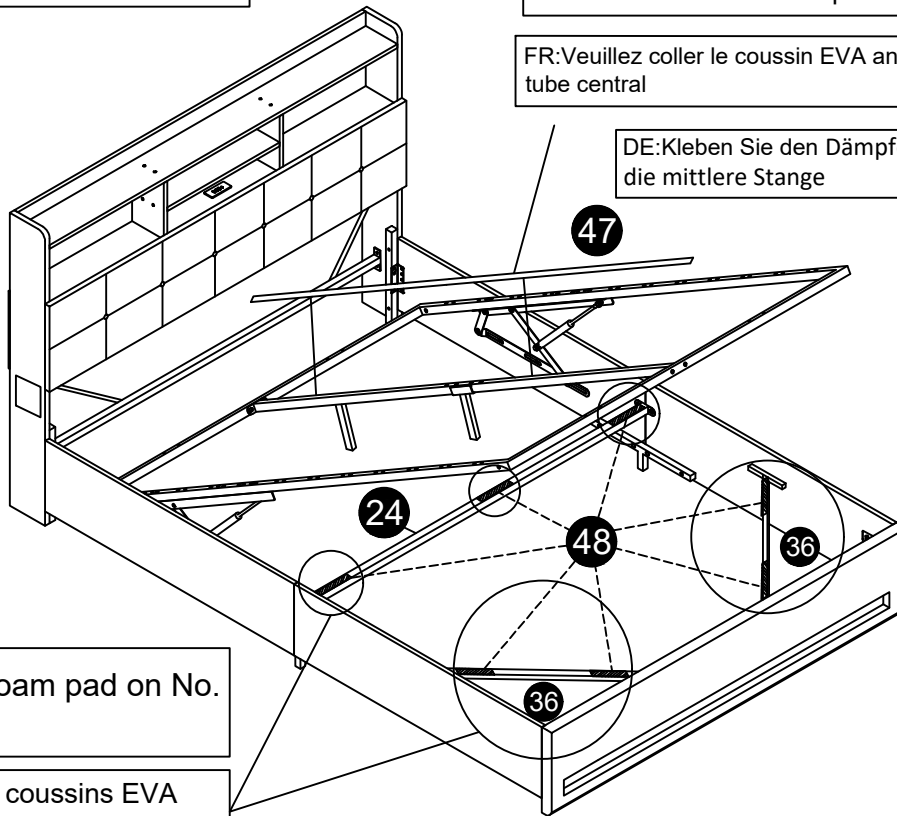

UK: Paste No. 48 foam pad on No. 24-36

FR: Veuillez coller les coussins EVA n°48 sur les tubes n°24 et n°36

DE: Kleben Sie die Dämpferstreifen Nr. 48 auf die Stangen Nr. 24-36

## Step31

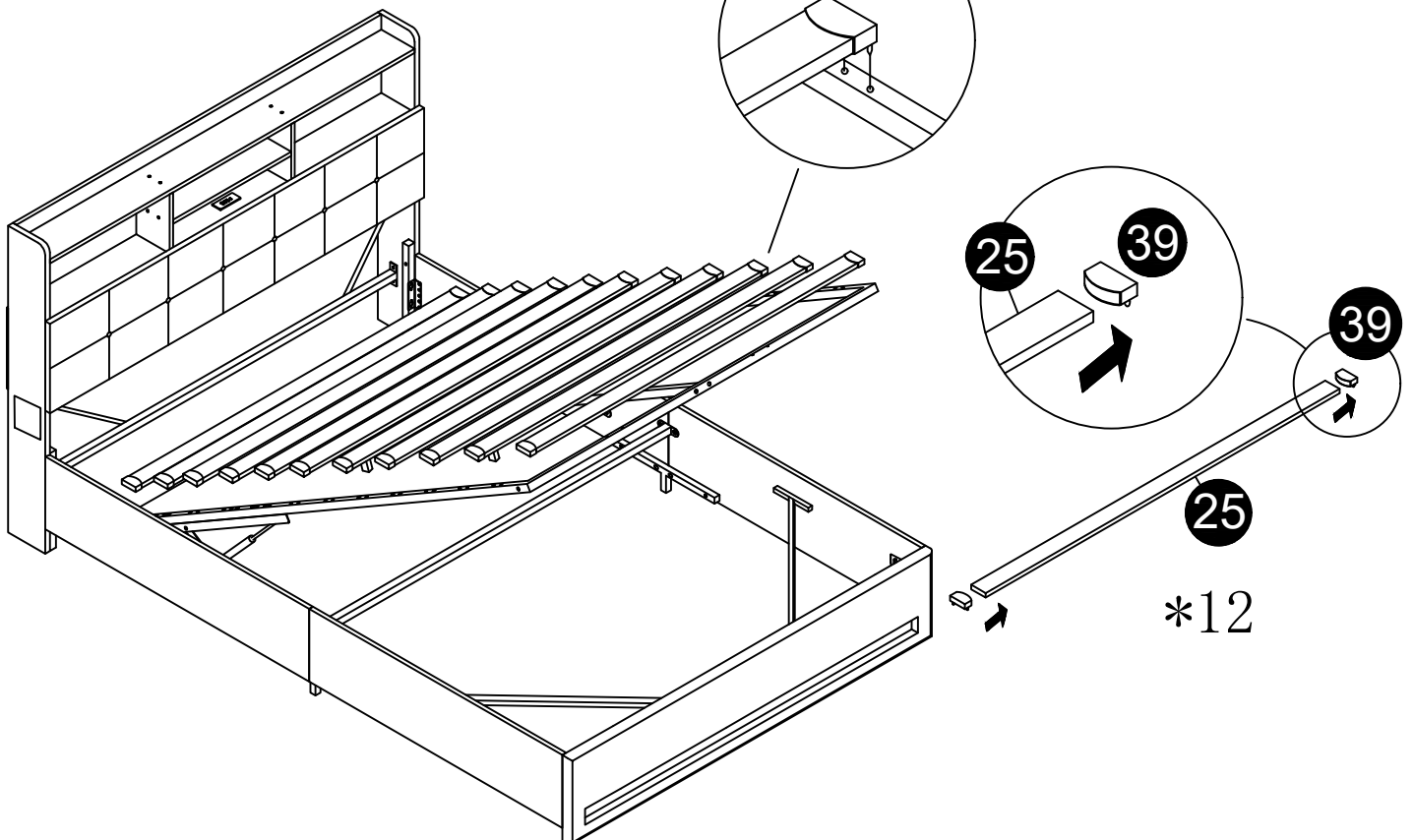
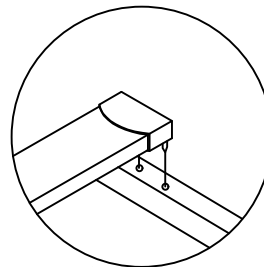

Step32

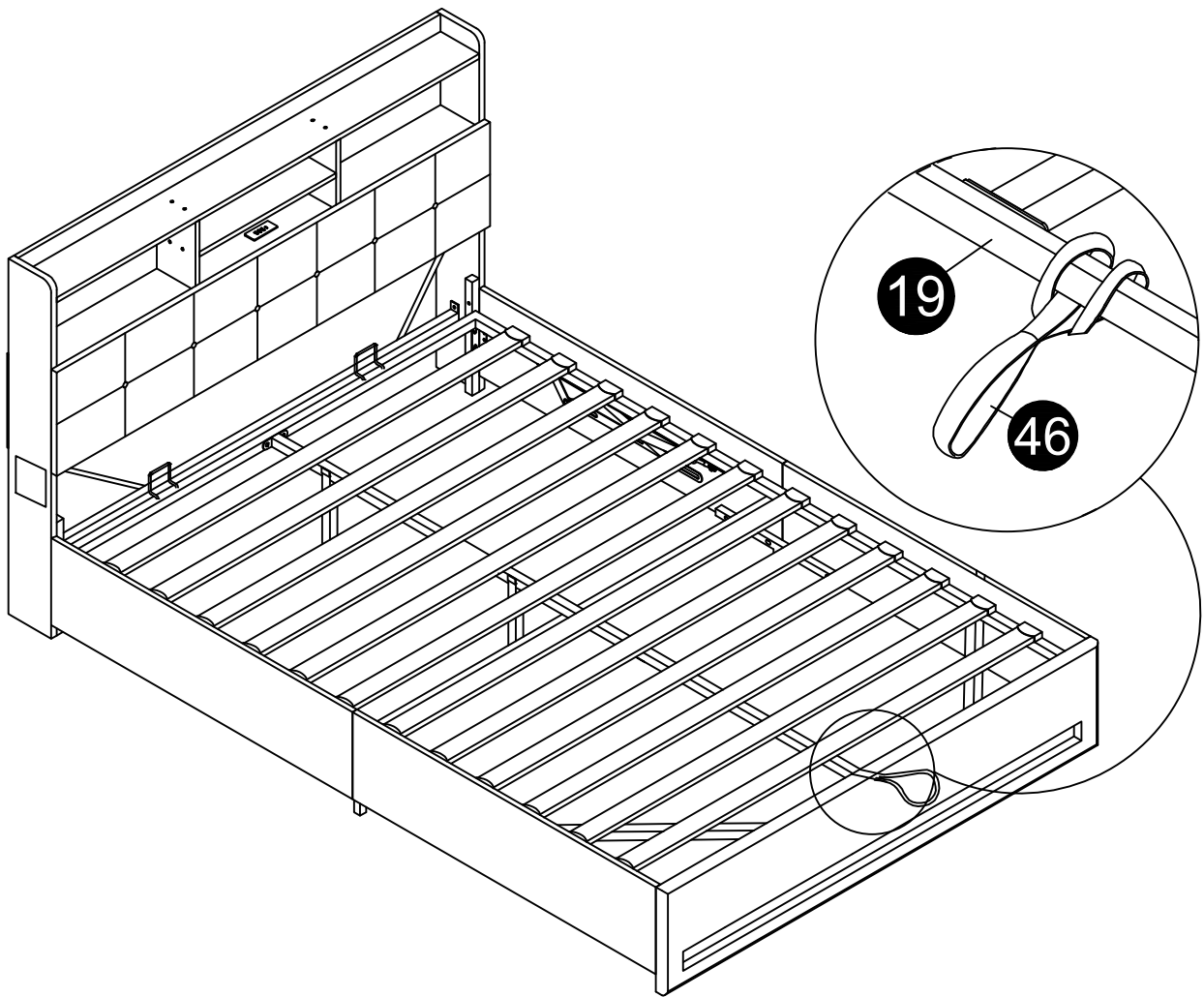

## Step33

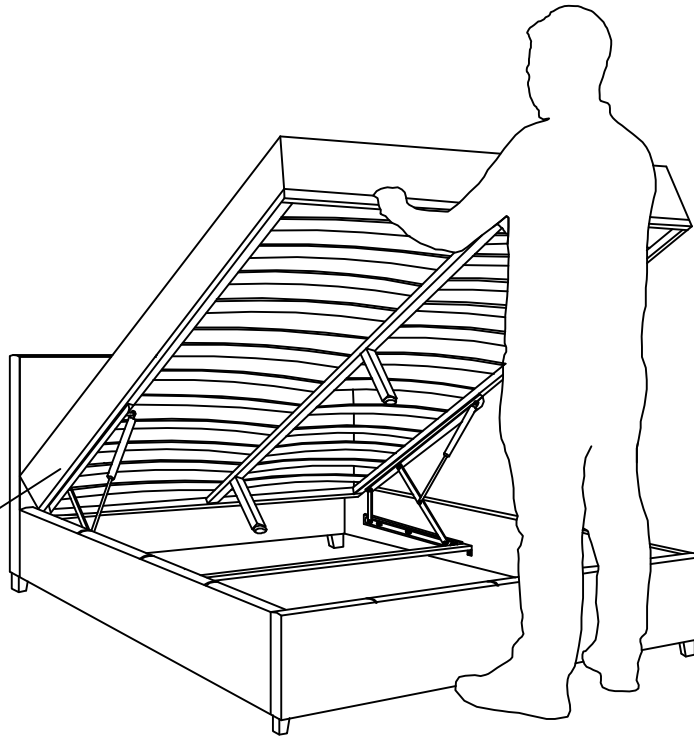

UK: Place the mattress on top for lifting and lowering

FR: Veuillez bien placer le matelas avant de lever ou abaisser le cadre

DE: Legen Sie vor dem Heben und Senken der Liegefläche eine Matratze darauf

