

Parts List For Bed

BED CARTON	HEADBOARD CARTON					
(10) HEADBOARD PANEL (11) FOOTBOARD PANEL	(10) HEADBOARD PANEL	1	2	3	4	5
PART #373801 HARDWARE BAG FOR BED ATTACHMENT TO FRAME	PART #373802 HARDWARE BAG FOR HEADBOARD ATTACHMENT TO FRAME	6	7	8		9
(1) 1/4-20 X 2 1/2" FLAT ALLEN HEAD SCREW-4 (2) 1/4-20 X 3/4" FLAT ALLEN HEAD SCREW-4 (3) 1/4-20 X 1/2" FLAT ALLEN HEAD SCREW-4 (4) 1/4-20 HEX NUT-4 (5) 1/4" ID X 5/8" OD FLAT WASHER-12 (6) ALLEN WRENCH (7) OPEN WRENCH	(1) 1/4-20 X 2 1/2" FLAT ALLEN HEAD SCREW-4 (3) 1/4-20 X 1/2" FLAT ALLEN HEAD SCREW-4 (4) 1/4-20 HEX NUT-4 (5) 1/4" ID X 5/8" OD FLAT WASHER-8 (6) ALLEN WRENCH (7) OPEN WRENCH	10		11		
(8) LEG EXTENSION-2 #379201 (9) PLASTIC GLIDE -4 #150960000	(8) LEG EXTENSION-2 #379201 (9) PLASTIC GLIDE -2 #150960000					
NOTE: PLASTIC GLIDES COME PRE-INSTALLED	NOTE: PLASTIC GLIDES COME PRE-INSTALLED					

PRODUCT FULLY ASSEMBLED

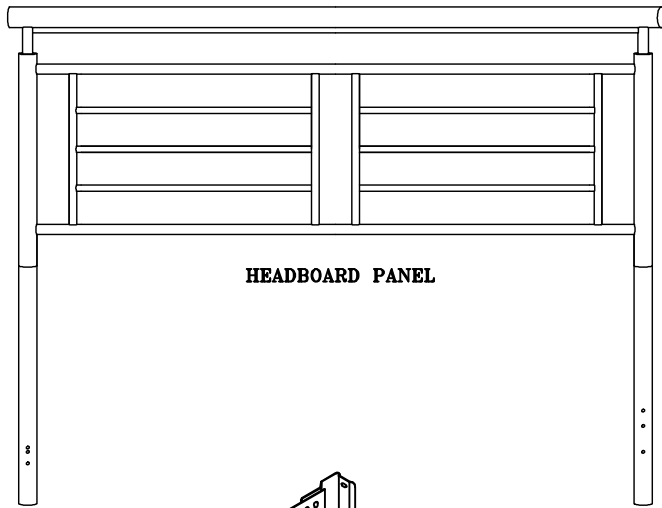

HEADBOARD PANEL

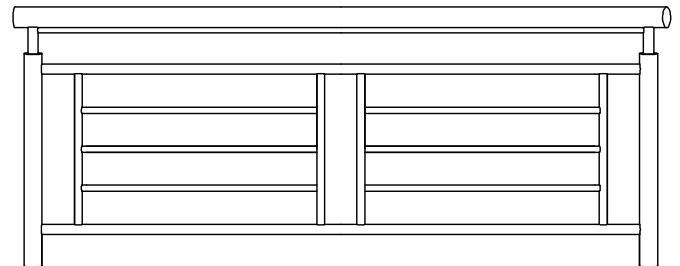

FOOTBOARD PANEL

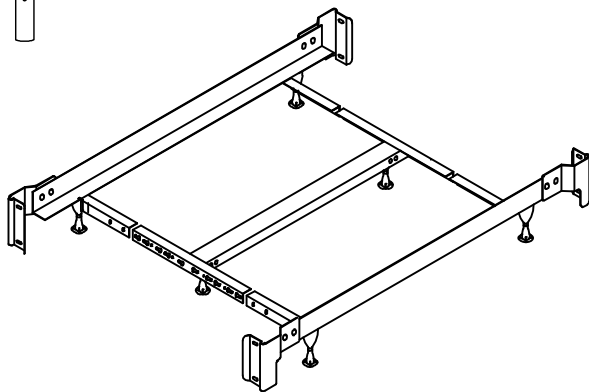

QUEEN - KING FRAME FULLY ASSEMBLED FRAMES

NOTE: SEE INSTRUCTIONS INCLUDED IN FRAME CARTON FOR FRAME ASSEMBLY

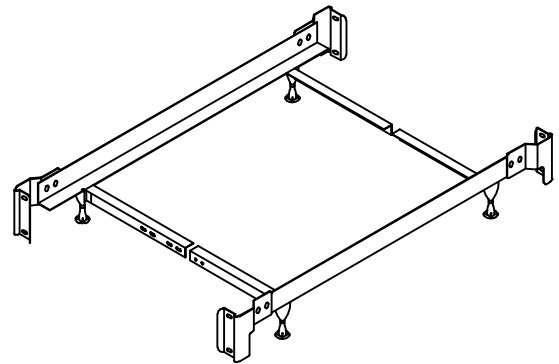

TWIN - FULL FRAME FULLY ASSEMBLED

NOTE: SEE INSTRUCTIONS INCLUDED IN FRAME CARTON FOR FRAME ASSEMBLY

Instruction Sheet

SAVE ALL PACKAGING MATERIALS UNTIL PRODUCT IS FULLY ASSEMBLED. HARDWARE AND SMALL PIECES MAY NOT BE SEEN AND COULD BE ACCIDENTALLY DISCARDED WITH PACKAGING MATERIALS.

FIGURE 1

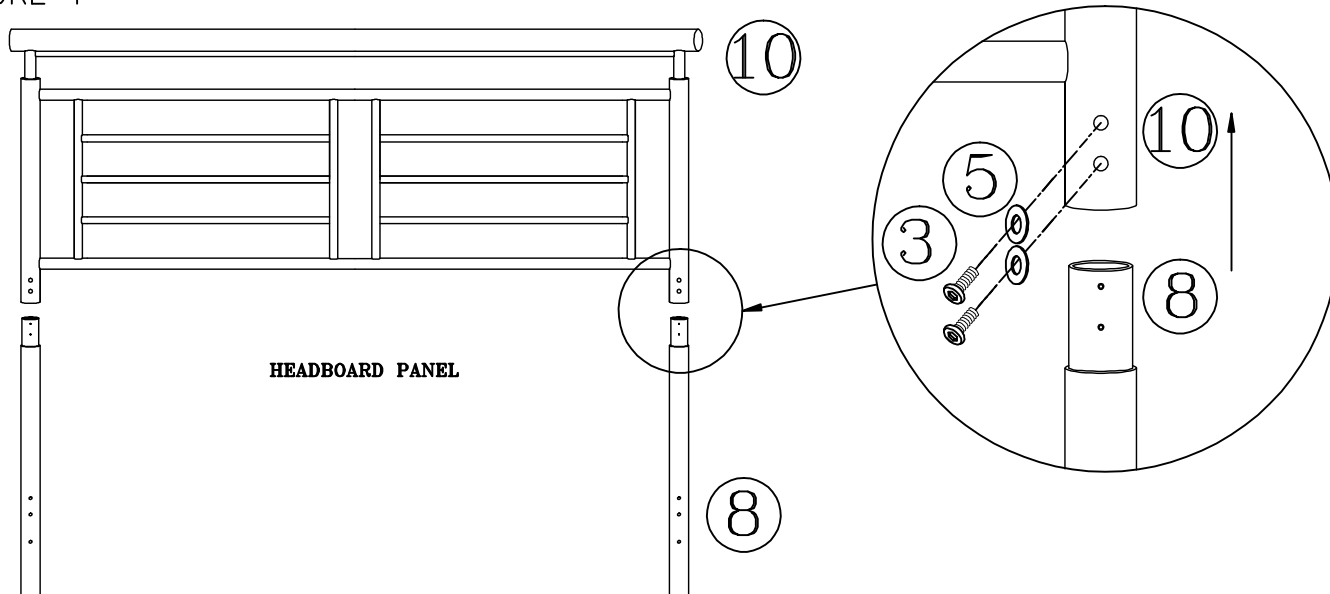
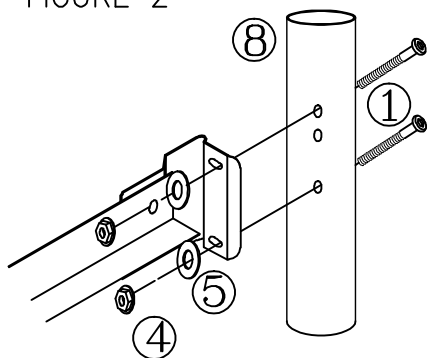

FIGURE 2



Step 1 Leg Extension Assembly

- Align top reduction of extension leg (8) with bottom of panel post (10). (See Figure 1)
- Now carefully insert extension leg (8) into bottom of panel (10) post.
- Secure leg extension (8) with screws (3) and flat washer (5) to panel (10).
- Tighten screws with Allen wrench (6).
- Repeat on other side of headboard panel.

Step 2 Headboard Assembly

- Place headboard and frame in desired location in room.
- Place 2 screws (1) through holes located in leg (8). (See Figure 2)
- Align bed frame bracket over screws.
- Place a flat washer (5) first and then a nut (4) on each screw. DO NOT TIGHTEN SCREWS COMPLETELY.
- Repeat on other side of headboard.
- Tighten all screws securely using the Allen wrench (6) and open wrench (7).

FIGURE 3

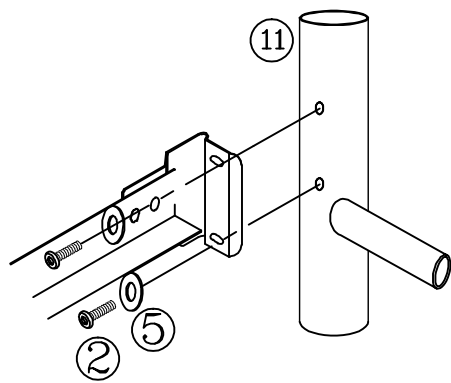

Step 3 Footboard Assembly

- Position footboard panel and align holes in the post (11) with holes in the frame bracket. (See figure 3)
- Place flat washer (5) on each screw (2). Insert through bracket and into post.
DO NOT TIGHTEN SCREWS COMPLETELY.
- Repeat on other side of footboard panel.
- Tighten all screws securely using the Allen wrench (6).