

# BAR STOOL

## Assembly Instruction



**Dear Customers,**

Thank you for purchasing our product. Please read this instruction manual carefully after receiving this product. It will help you assemble this product quickly, safely and correctly. You can keep this manual for future reference.

# CHAIR

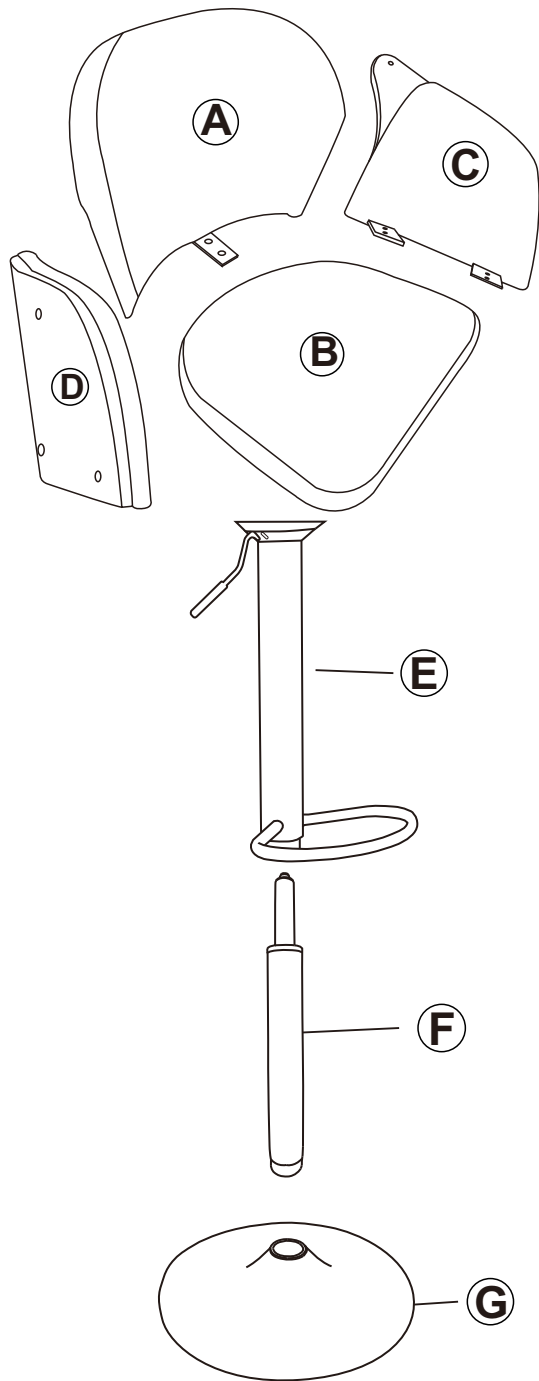

## Hardware parts

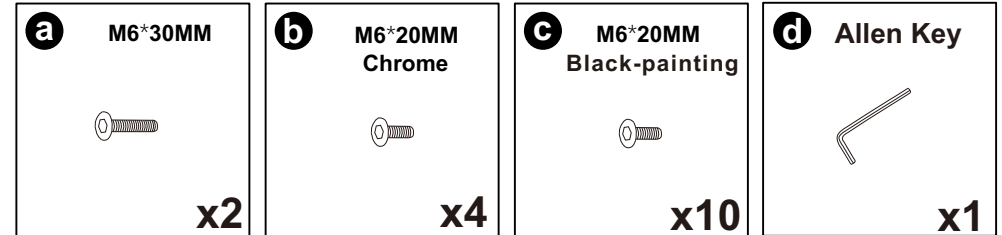

## Main structure accessories

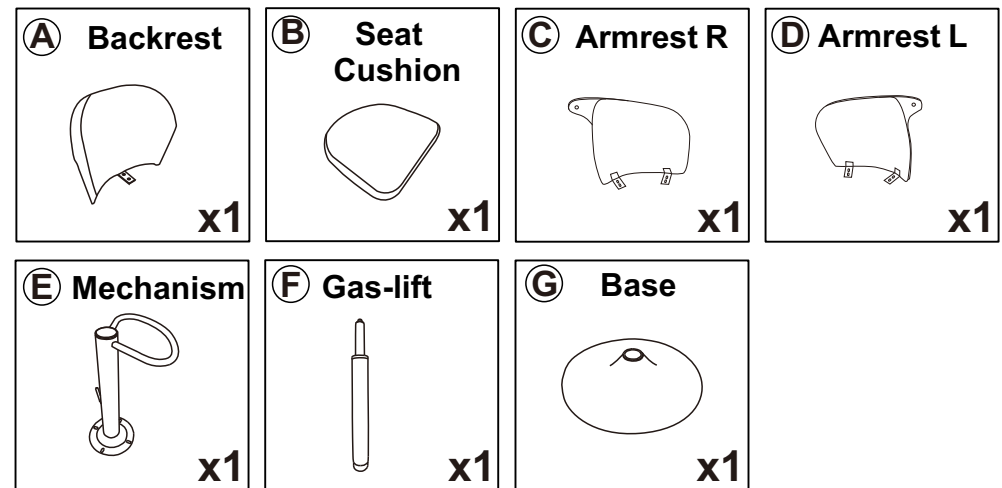

# Kind Reminder:

- \*Due to the size of our product, it would be easier to assemble it with your partner together.
- \*Lubricate all parts and tighten all bolts every 6 months or whenever needed.

### STEP 1

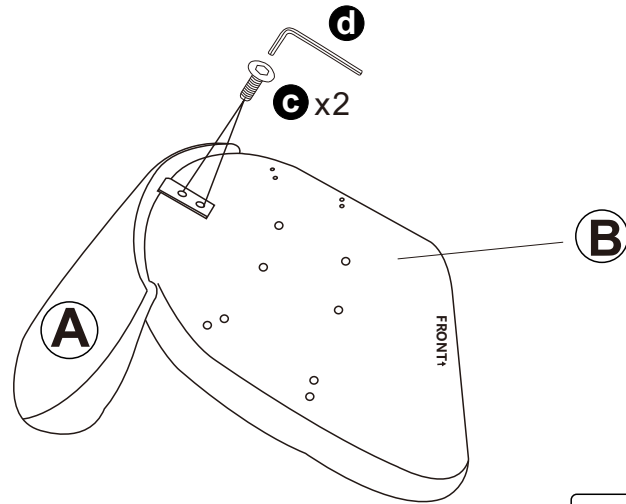

**c** x2

**d** x1

#### Note:

1. Insert 2 x screws **c** halfway.
2. Tighten each screw individually to 100% tightness.

### STEP 2

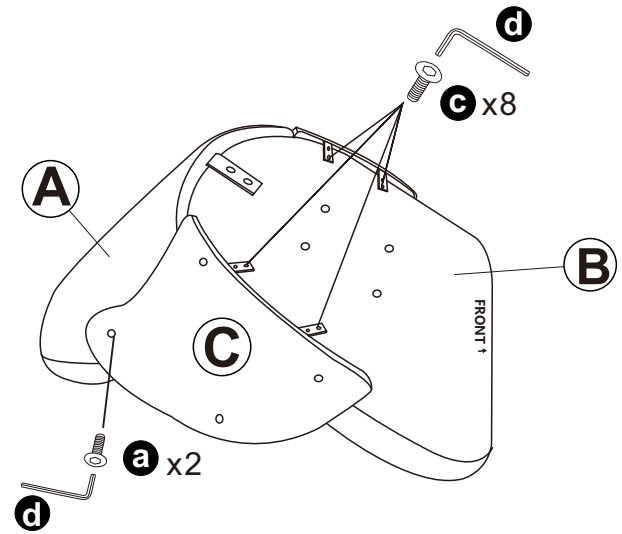

**a** x2

**c** x8

**d** x1

#### Note:

1. Insert 8 x screws **c** and 2 x screws **a** halfway.
2. Tighten each screw individually to 100% tightness.

### STEP 3

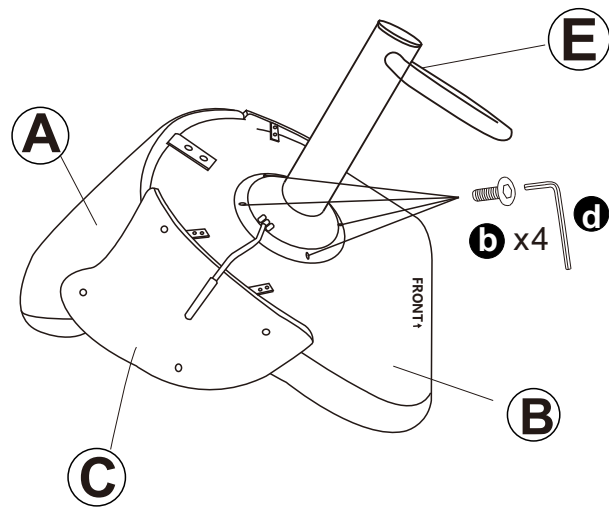

**b** x4

**d** x1

#### Note:

When you screw all the **b**, you could tighten 100% of all screws.

### STEP 4

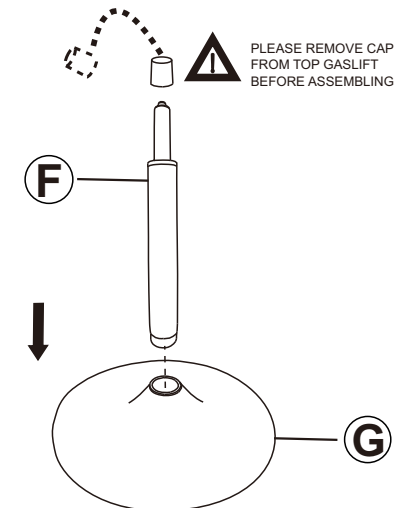

PLEASE REMOVE CAP  
FROM TOP GASLIFT  
BEFORE ASSEMBLING

#### Note:

Please kindly note that the cap should be removed from the top of the gaslift before assembling.

## STEP 5

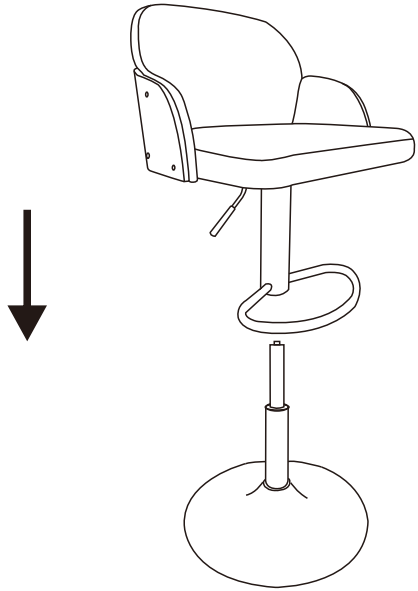

## STEP 6

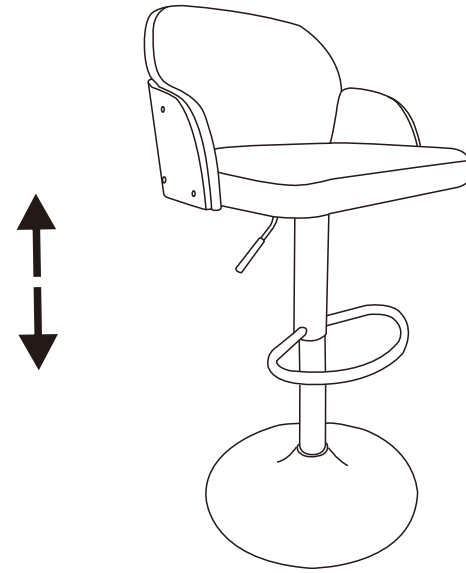

### **Note:**

Before using the chair, please kindly check all screws are fully tightened.