

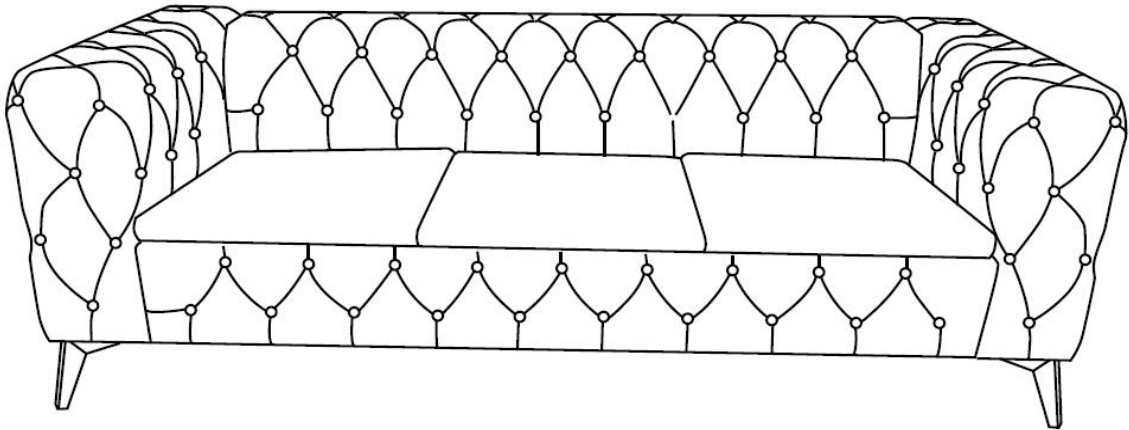





Assembly Instructions

Note: Please help to read my instruction before you ready to assemble.

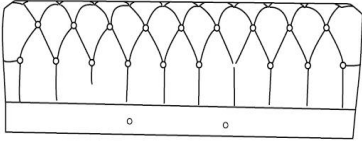
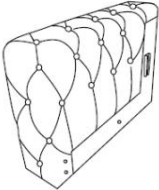
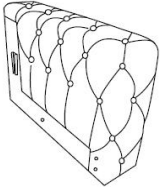

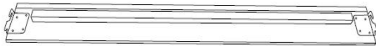

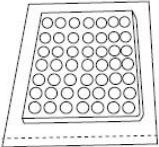
Sofa



Part List

Label	Picture	Description	QTY (PCS)
A		Backrest	1
B		Left Armrest	1
C		Right Armrest	1
D		Seat	1
E		Front Rail	1
F		Seat Cushion	3
G		Compressed Seat Spring Package	2
H		Iron Leg	4

Hardware

①		Bolt(M8*60MM)	3
②		Bolt(M8*25MM)	9
③		Flat Washer	11
④		Spring Washer	11
⑤		Allen Wrench	1

Assembly Preparation

All Including:

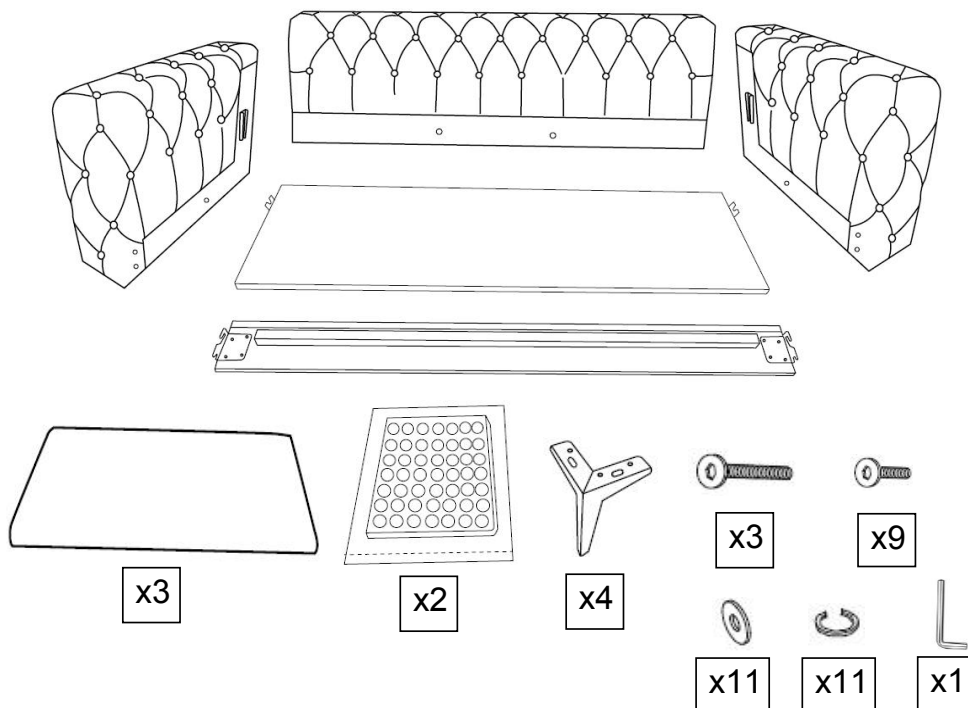

NOTICE:

- Please read the instruction from cover to cover in detail.Thanks.
- Installed by at least two adults
- To avoid damaging your furniture , Please don't assemble on flooring or carpet.
- Please assemble on a clean non-marring surface, example for packing foam.
- Saving all packaging until have finished.

Assembly Steps

OVERVIEW

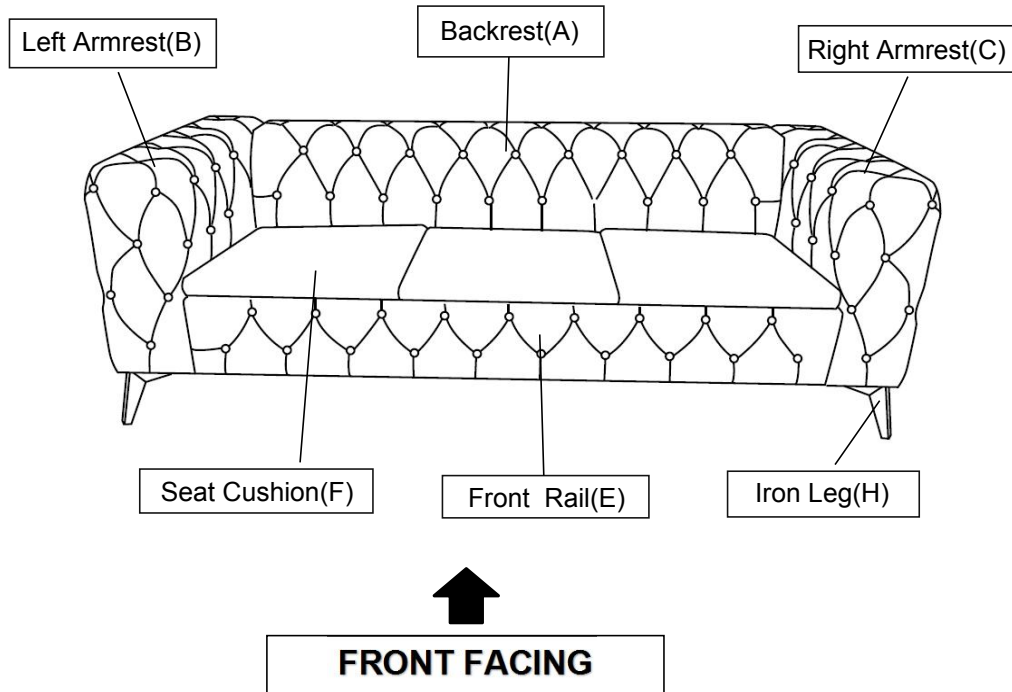

This Sofa has multiple parts and may require up to 60 minutes to assemble. To give you an overview of the Sofa parts, the above picture is to help you put the various parts into perspective. Please read through the instructions below to familiarise yourself with the parts and steps before assembly.

Note: It is recommended that you have an adult partner to assist during the entire assembly process.

Step 1

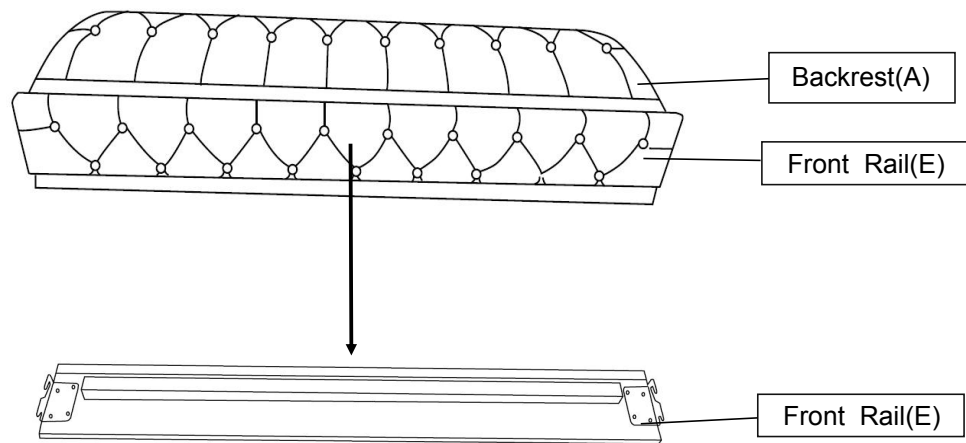

Remove the Front Rail(E) from Backrest(A) as shown in the picture.

Step 2

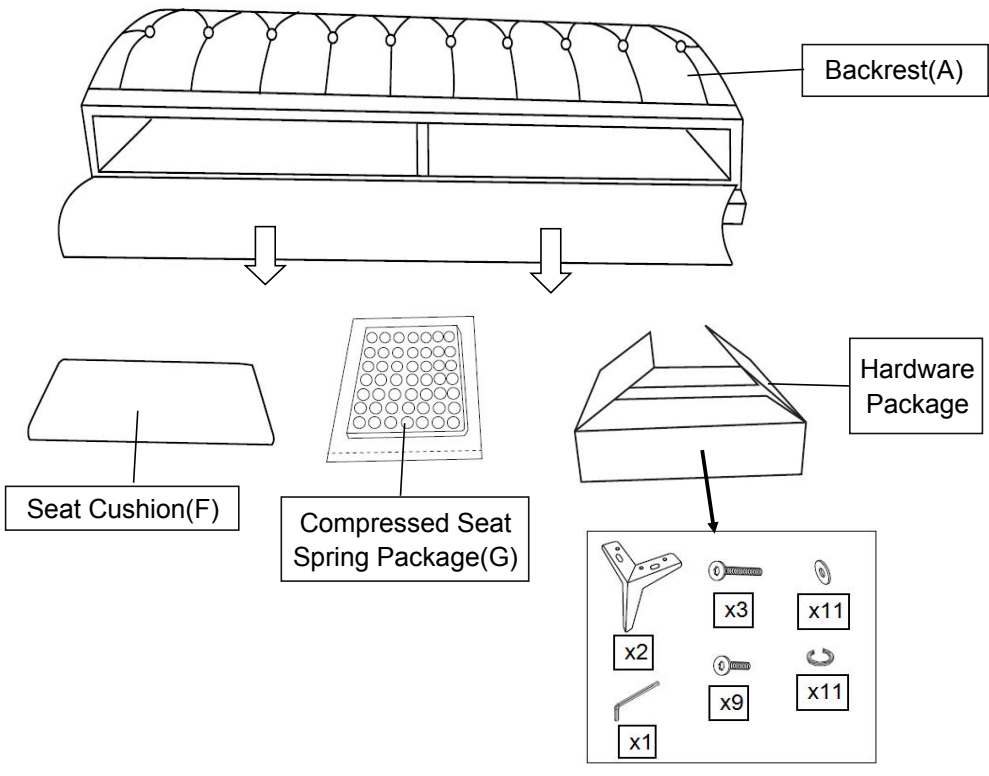

Open the magic tape on the bottom of Backrest(A). Remove Seat Cushion(F), Compressed Seat Spring Package(G), and Hardware Package from Backrest(A).

Step 3

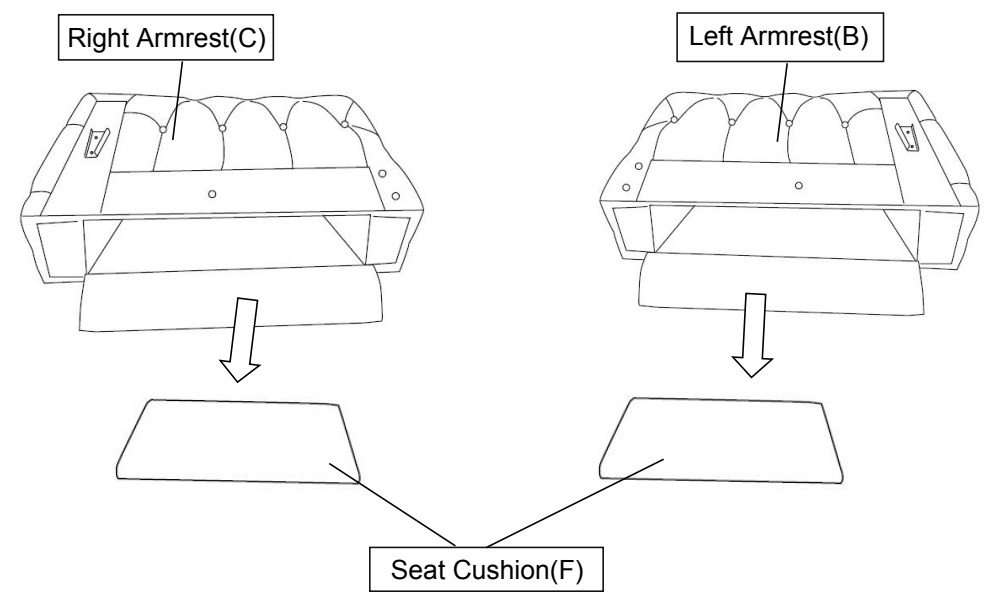

Open the magic tape on the bottom of Right Armrest(C) and Left Armrest(B). Remove the Seat Cushion(F) from Right Armrest(C) and Left Armrest(B).

Step 4

Left Armrest(B)

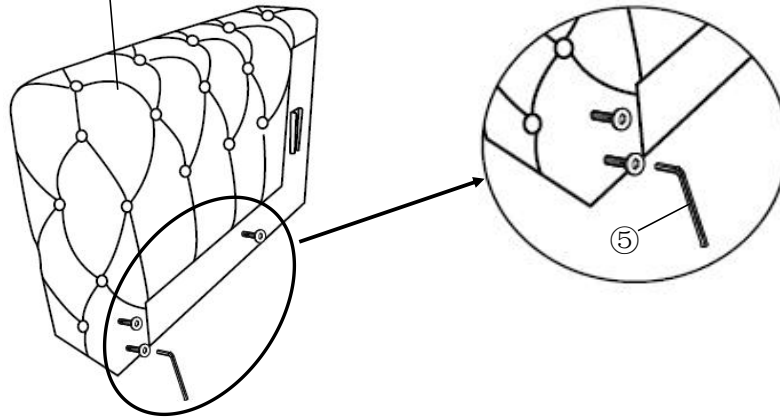

Loosen the 3 bolts in Left Armrest(B) around half inch by Allen Wrench(5).
Repeat the same step to loosen 3 bolts in Right Armrest(C).

Step 5

Right Armrest(C)

Front Rail(E)

Left Armrest(B)

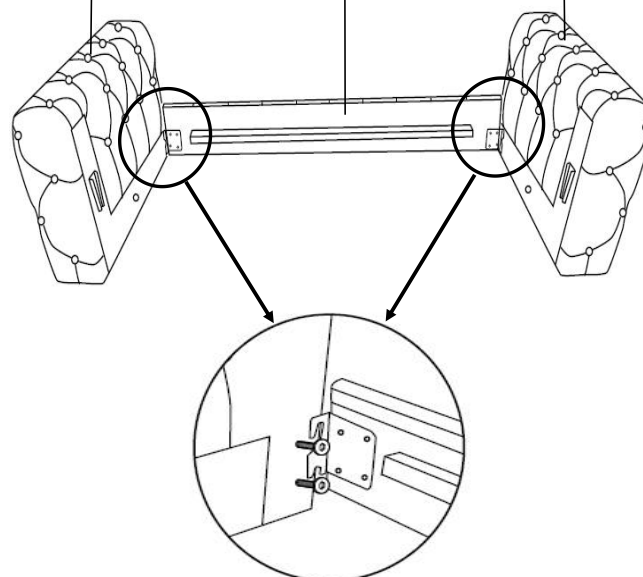

With the assistance of your partner,slide the hook in the eng of Front Rail(E) into the bolts on the Left Armrest(B) and Right Armrest(C), as shown in Picture.

Step 6

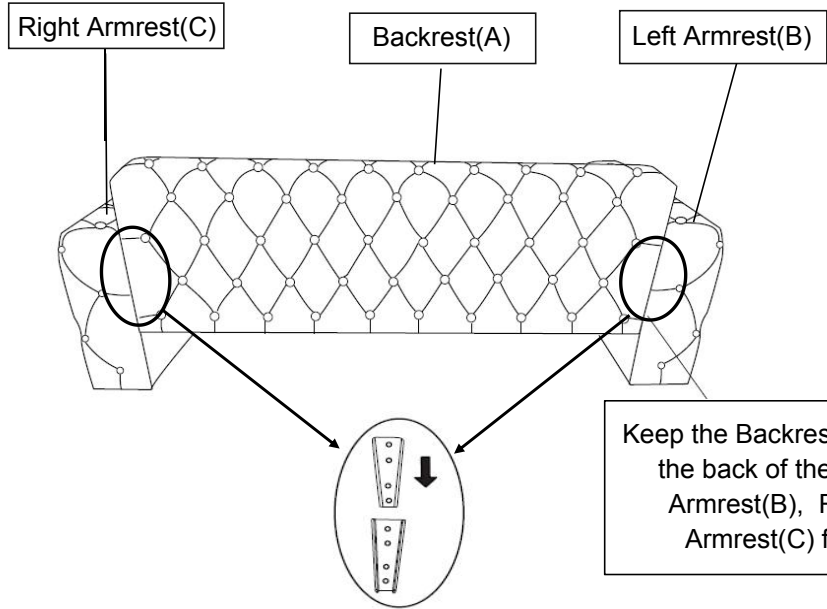

Slide the Tapered Connectors on the Backrest(A) into the Tapered Connectors on the Left Armrest(B) as shown in the picture.

Repeat the same process with the Right Armrest(C).

Note: Make sure the Tapered Connectors on Backrest(A) lock into the Tapered Connectors on the Left Armrest(B) and Right Armrest(C).

Assistance from an adult partner is necessary for this assembly process.

During this assembly process - do exercise caution. You may need to use your hand to press down and or pave away the padded surface to facilitate the 'slip and slide' assembly.

Caution: Ensure that your fingers do not get caught or pinched in the assembly process.

Step 7

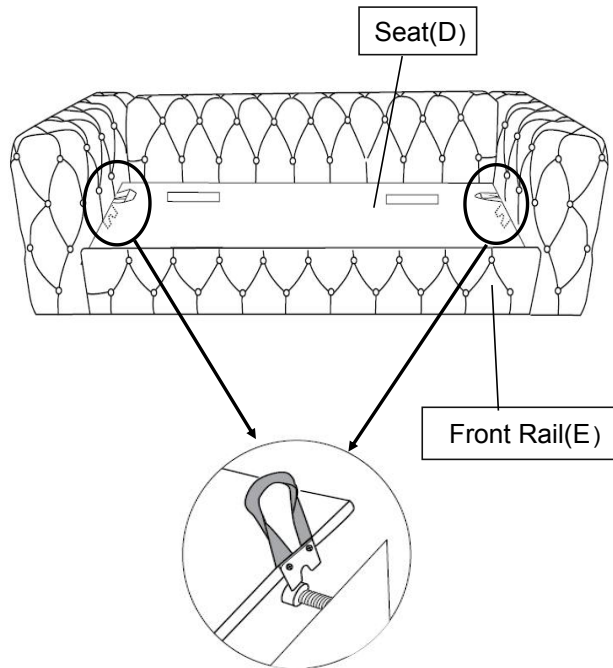

With the assistance of your partner, lift the rope on the two sides of Seat(D) by hand.

Put the Seat(D) on the wood bar of the Front Rail(E) and then slowly place it down as shown above.

Note: All the u-shaped iron sheet need clamped to the bolt.

Step 8

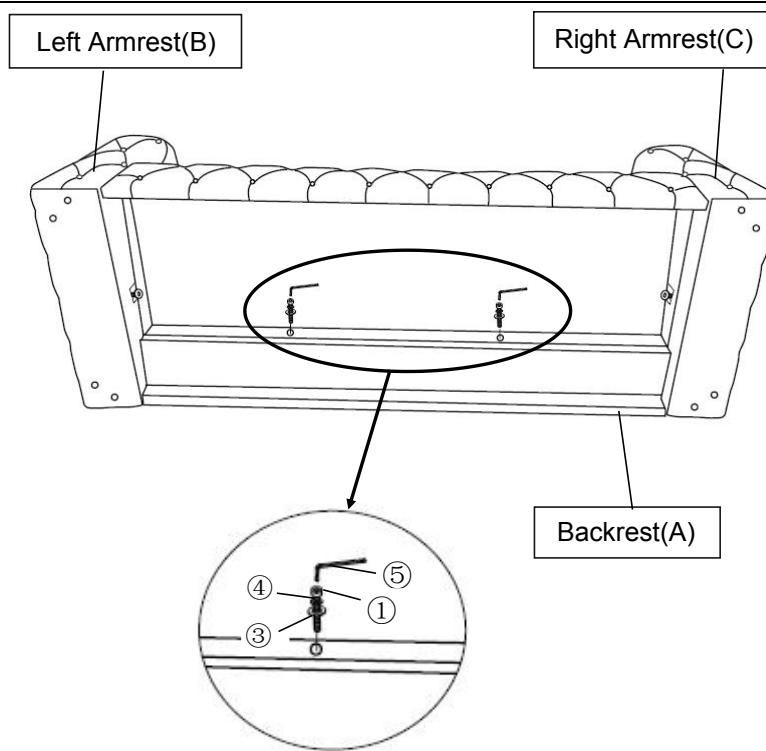

Tilt and lay the Sofa onto a flat surface.

Using the Bolt(①), Spring Washer(④), Flat Washer(③), with Allen Wrench(⑤) turning clockwise in the bottom of Backrest(A) as pictured above.

Step 9

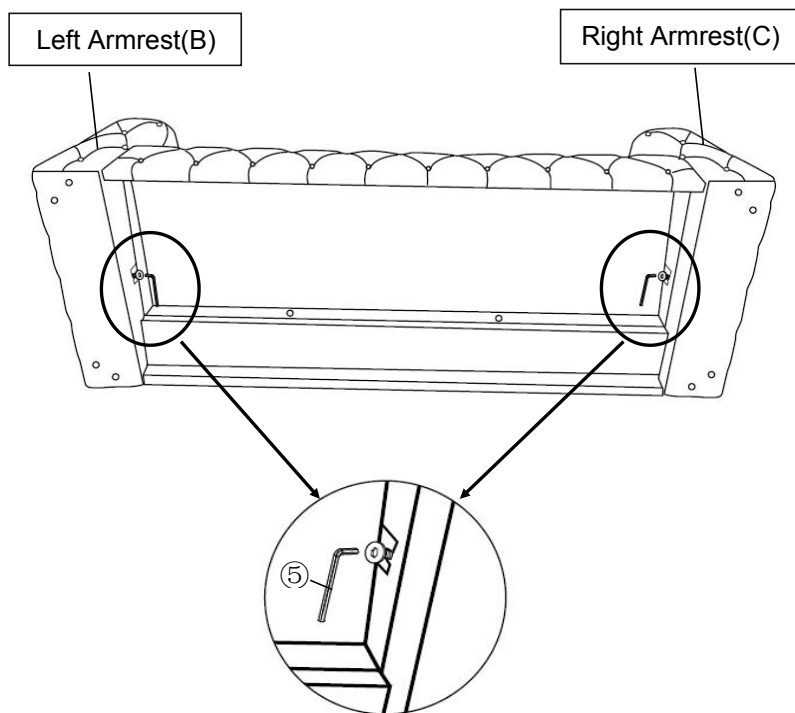

Tighten the Bolts on the Left Armrest(B) and Right Armrest(C) by Allen Wrench(⑤).

Step 10

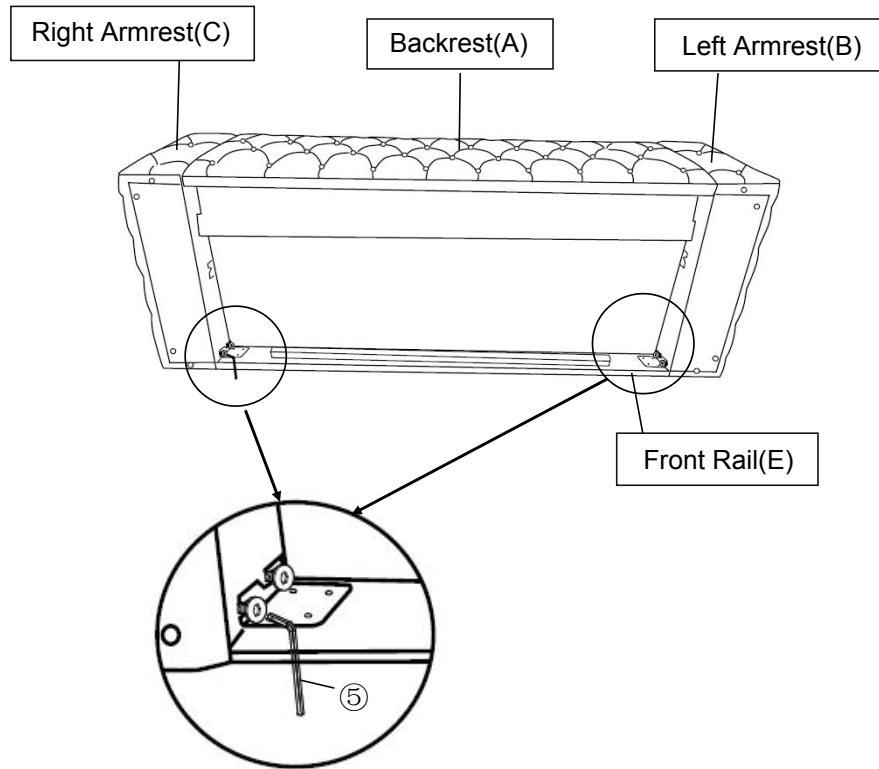

Change tilt and lay the Sofa another side onto a flat surface.
Tighten all the Bolts at the end of bottom Left Armrest(B) and Right Armrest(C) by Allen Wrench(5) as pictured above.
Tighten the Bolts fully in a sequential manner.

Step 11

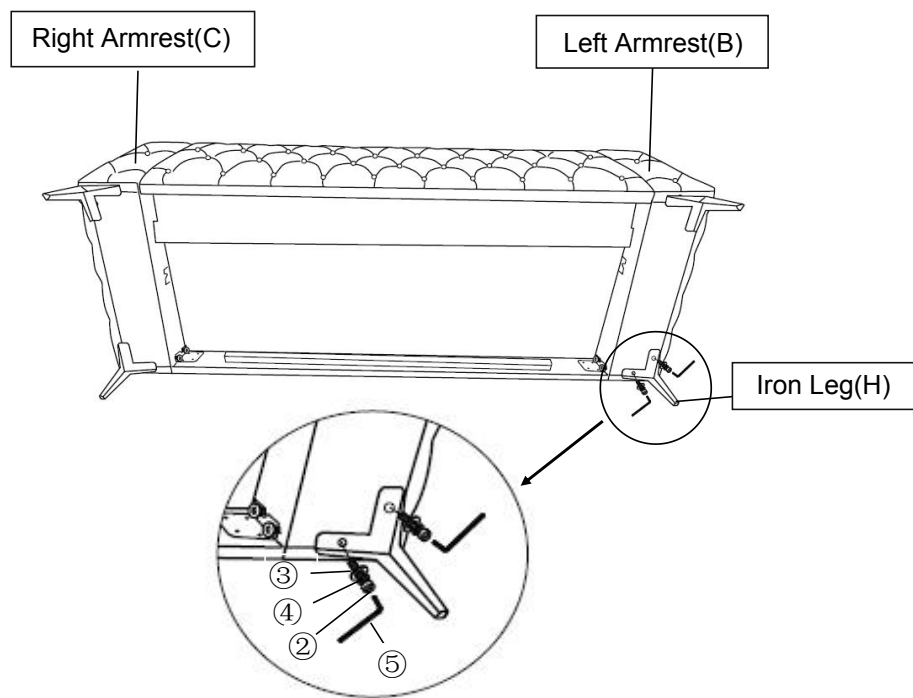

Install the Iron Leg(H) at the bottom of Left Armrest (B) by using Bolt(2),Spring Washer(4),Flat Washer(3),with Allen Wrench(5) turning clockingwise until tight.
Repeat the same step to install remaining Iron legs.

Step 12

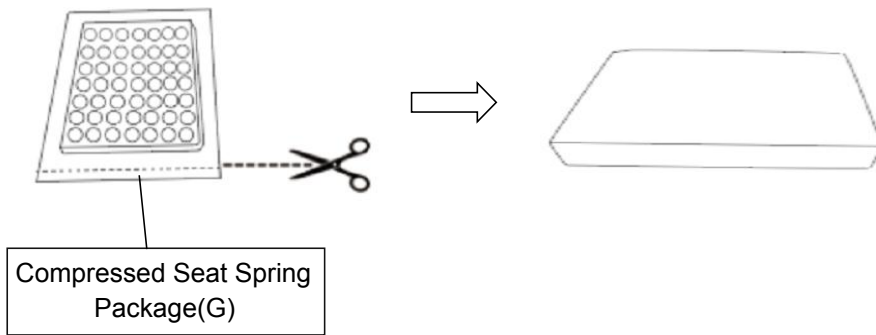

Cut the Compressed Seat Spring Package(G) along the side.

Step 13

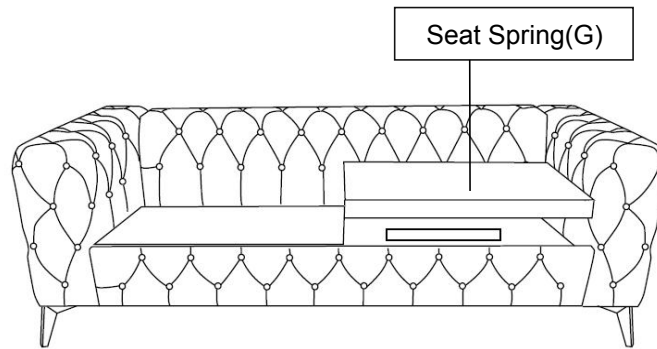

Turn the Sofa to its upright position.
Place the Seat Spring(G) onto the Sofa.

Step 14

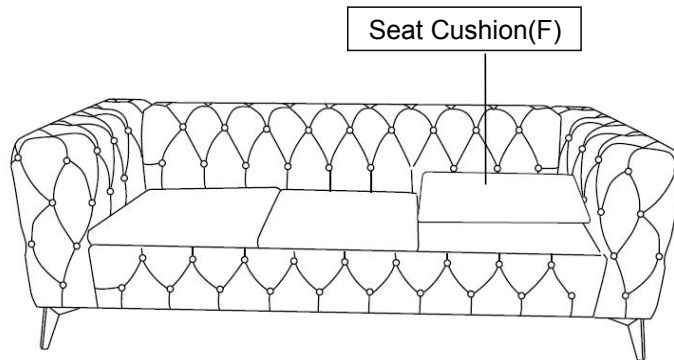

Put the Seat Cushion(F) on the sofa.

Step 15

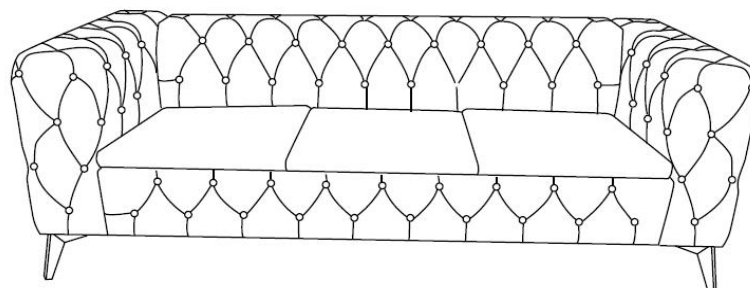

Your Sofa is ready for use.
This sofa can only be used on a flat, level surface.