

Assembly Instructions

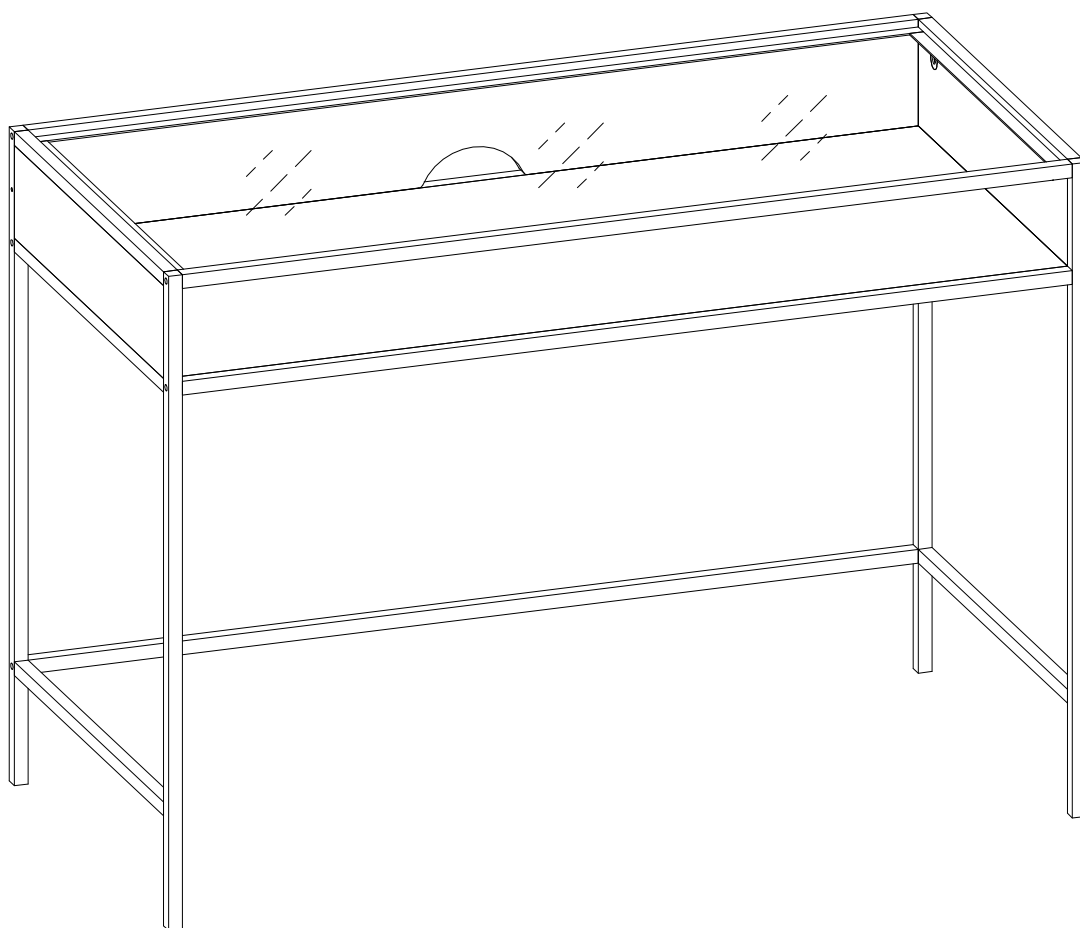

General Assembly Guidelines

- I. Ensure that all parts and hardware are available before beginning assembly.
- II. Follow each step carefully to ensure the proper assembly of this product.
- III. Two people are recommended for ease in the assembly of this product.
- IV. The two main types of hardware used to assemble this product are : screws and bolts.
- V. A Phillips head screwdriver is required for the assembly of this product .

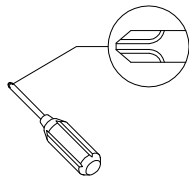



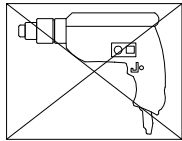

- VI. Power tools should not be used to assemble this product .

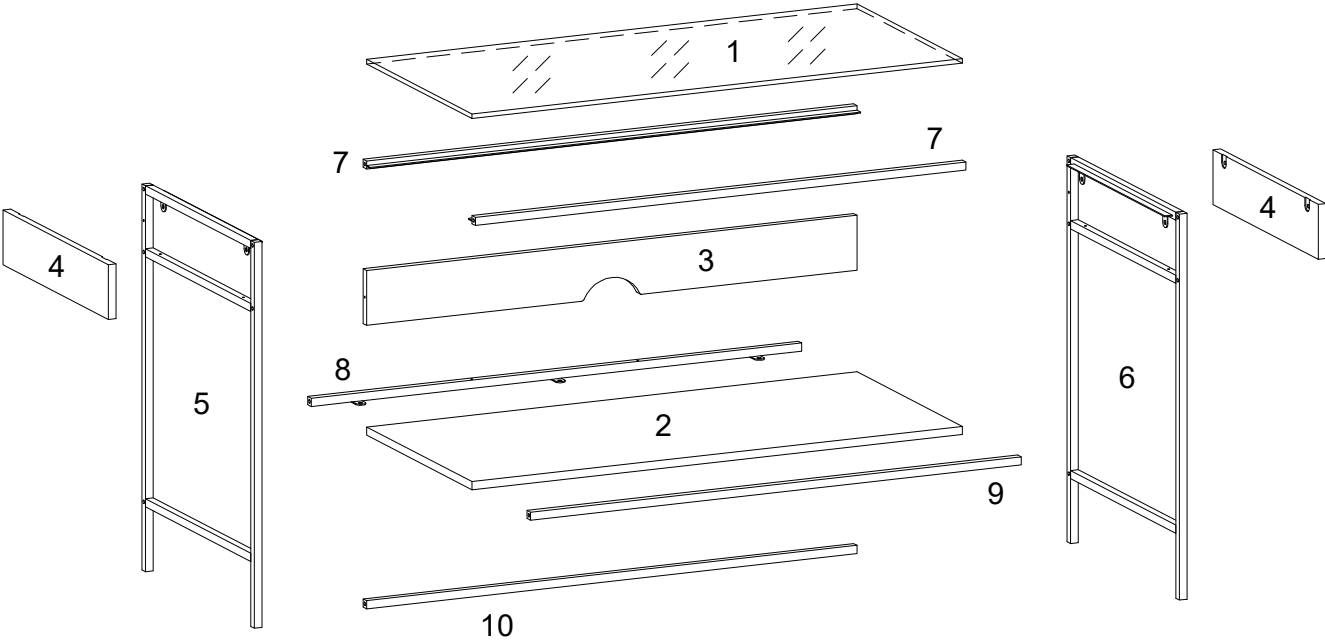

Parts List



Hardware List

A		Ø1/4"x30mm	Bolt	10 pcs
B		Ø1/4"x12mm	Bolt	10 pcs
C		Ø4x35mm	Screw	8 pcs
D		30x10mm	Glass pads	10 pcs
E		M 4	Hex Key	1 pc

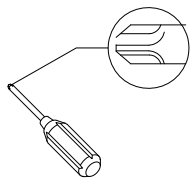

Philips head screwdriver required for assembly
(not included)

*The hardware quantities listed above are required for proper assembly.
Some extra hardware may also have been included.*

Step 1

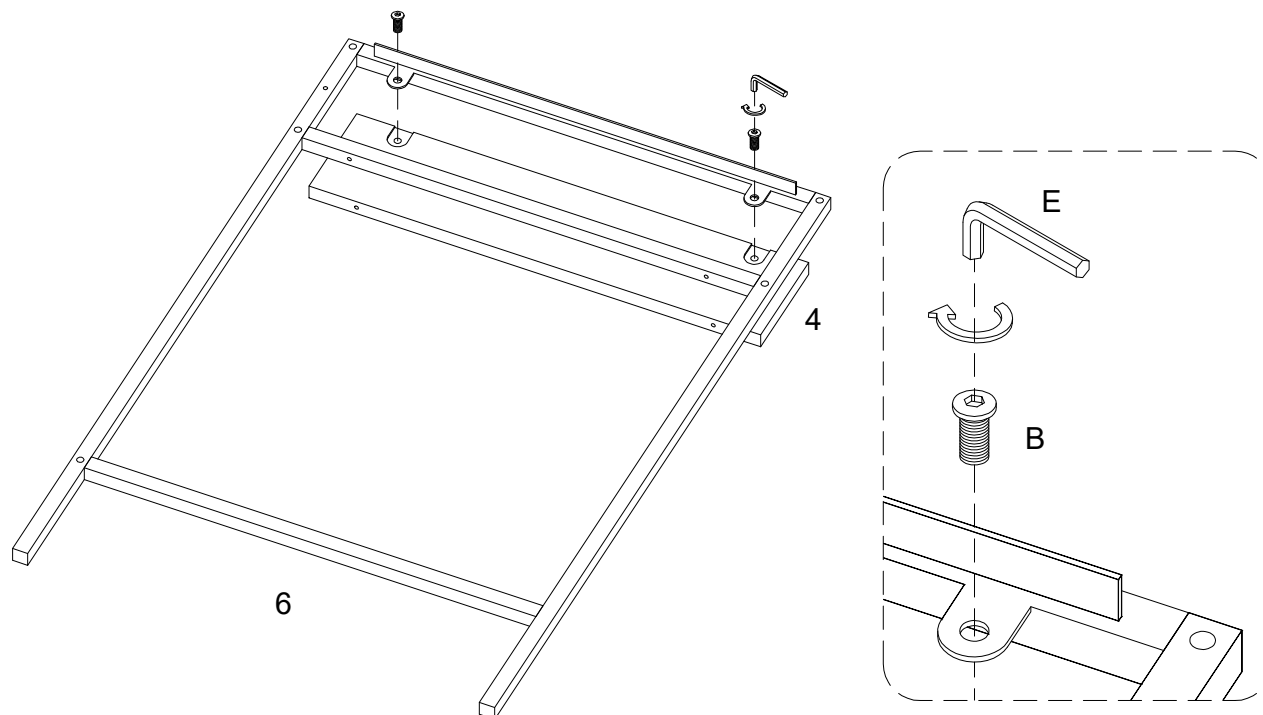

Attach part (6) to part (4) using bolt (B) with hex key (E).

Step 2

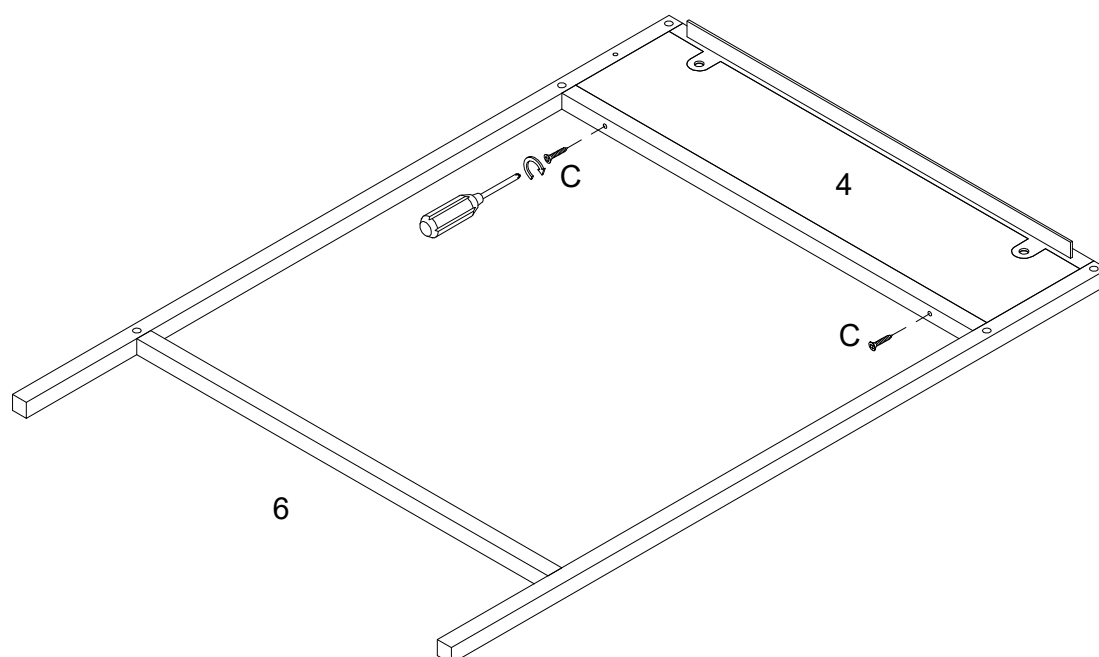

Attach part (6) to part (4) using screw (C) with screwdriver.

Step 3

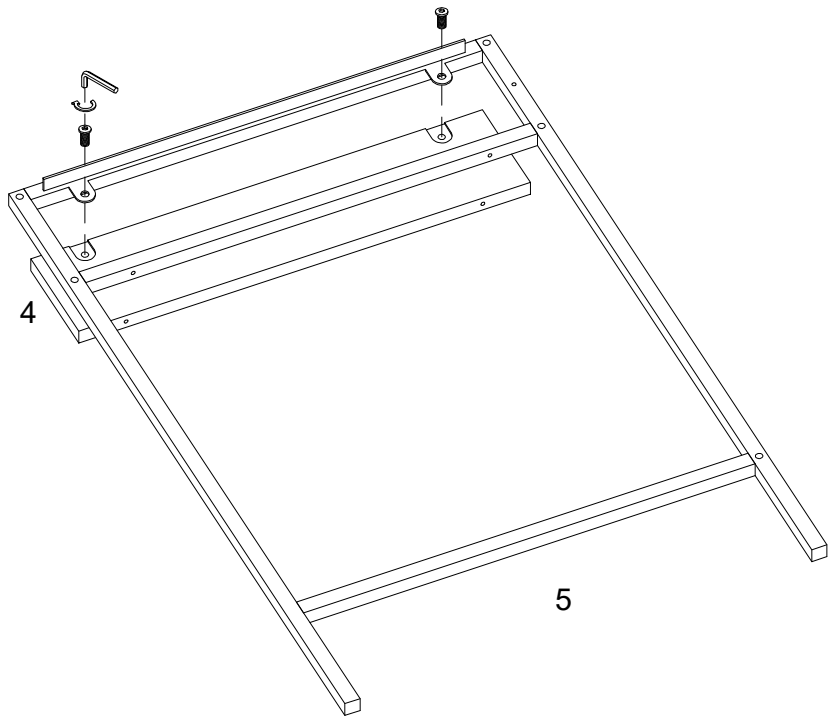
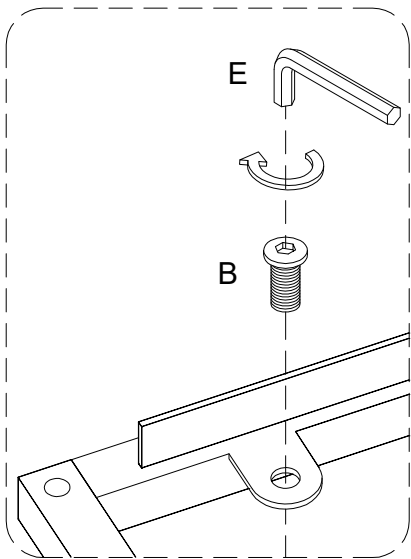

Attach part (5) to part (4) using bolt (B) with hex key (E).

Step 4

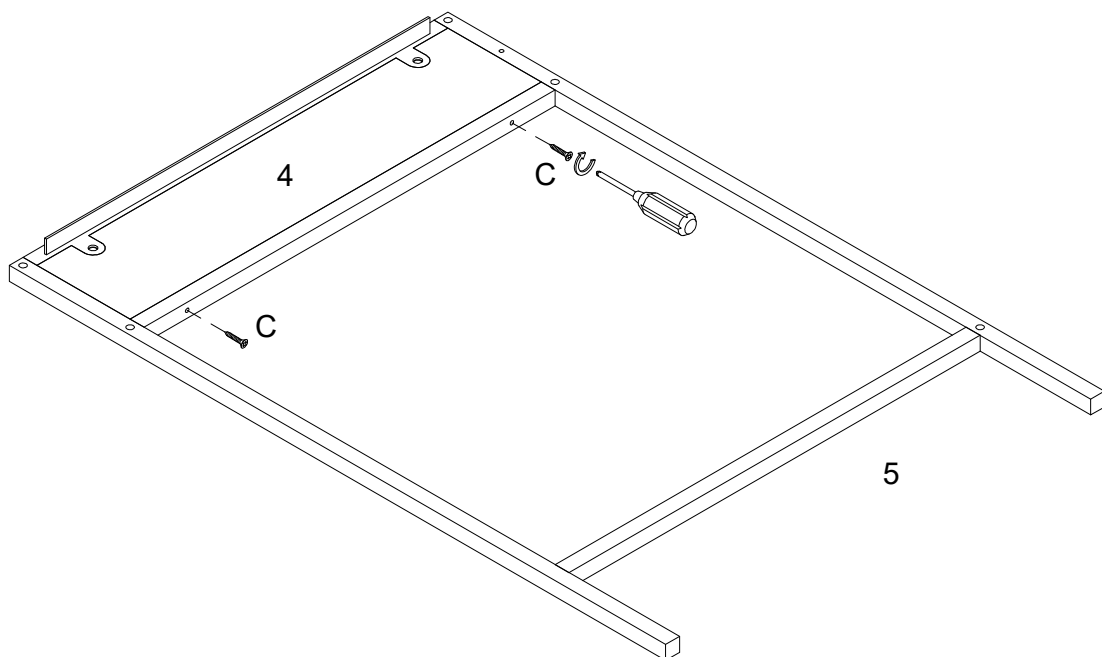

Attach part (5) to part (4) using screw (C) with screwdriver.

Step 5

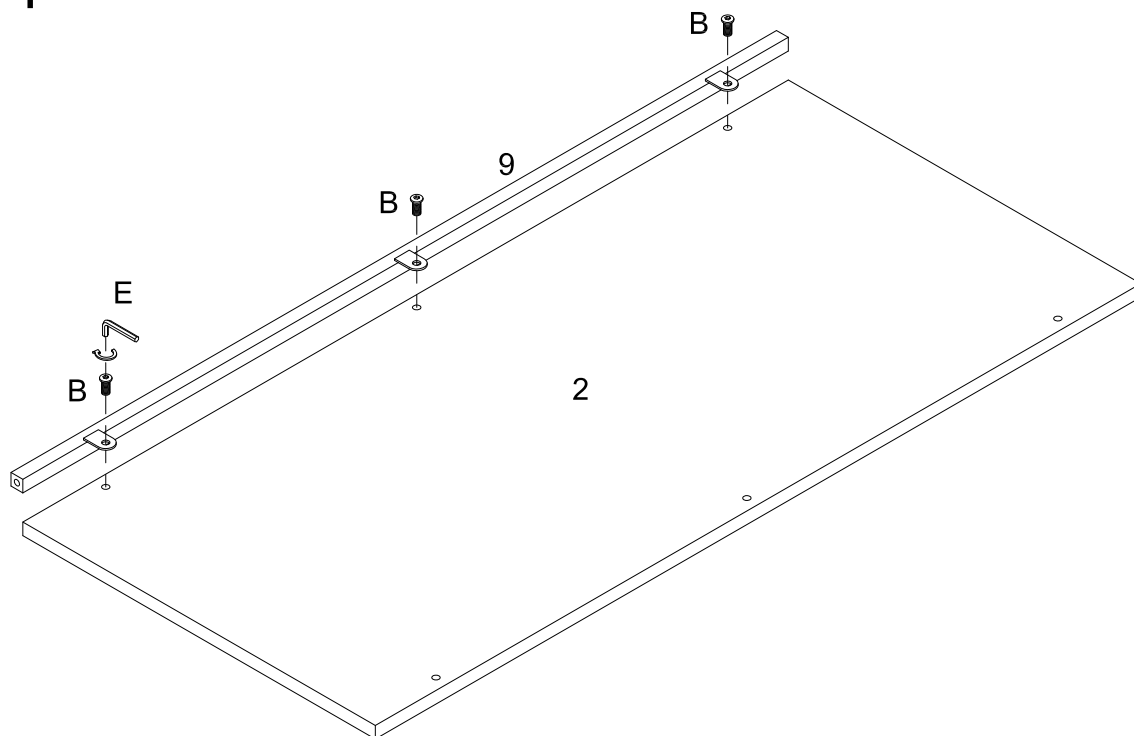

Attach part (9) to part (2) using bolt (B) with hex key (E).

Step 6

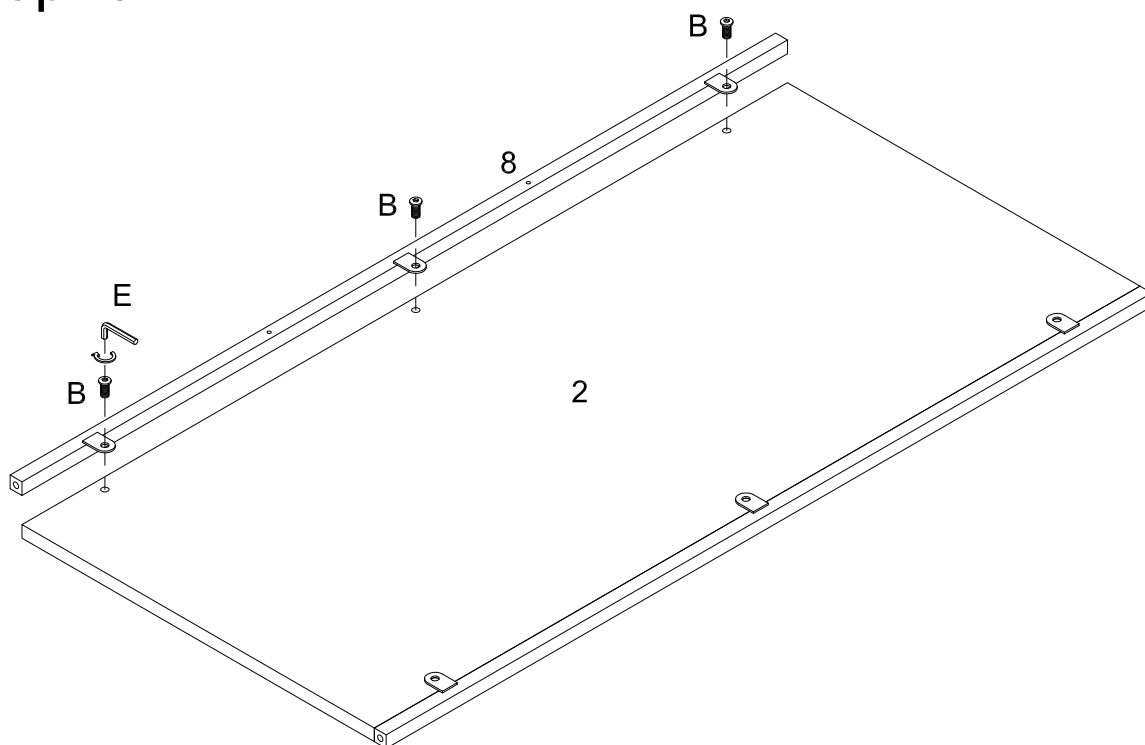

Attach part (8) to part (2) using bolt (B) with hex key (E).

Step 7

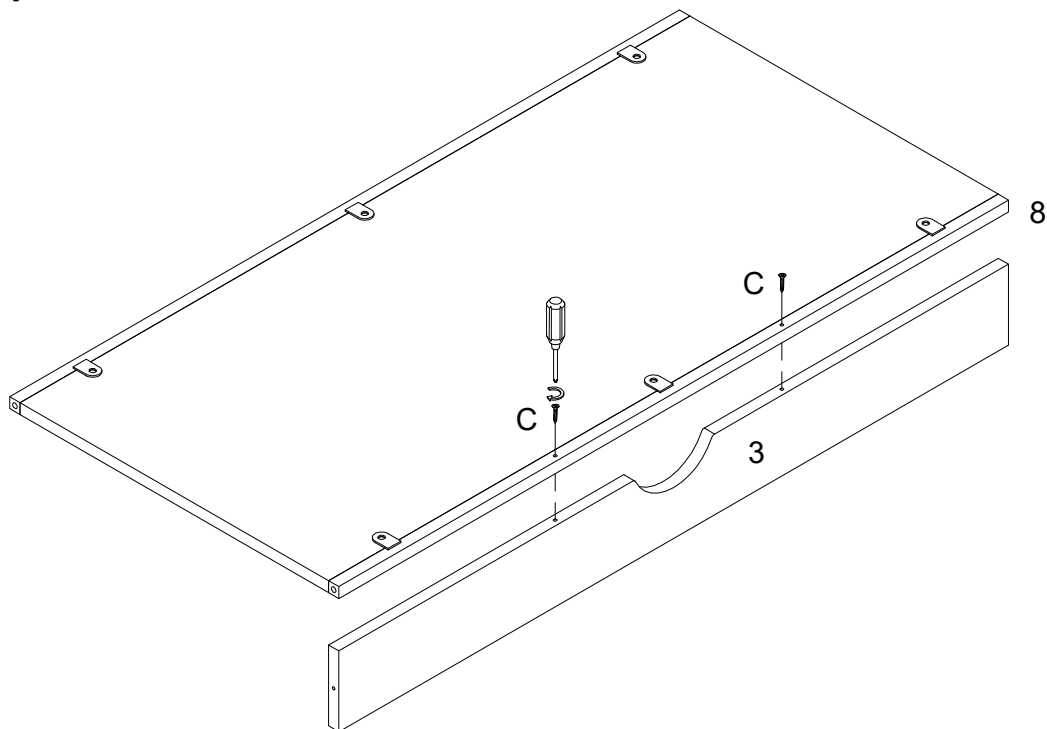

Attach part (8) to part (3) using screw (C) with screwdriver.

Step 8

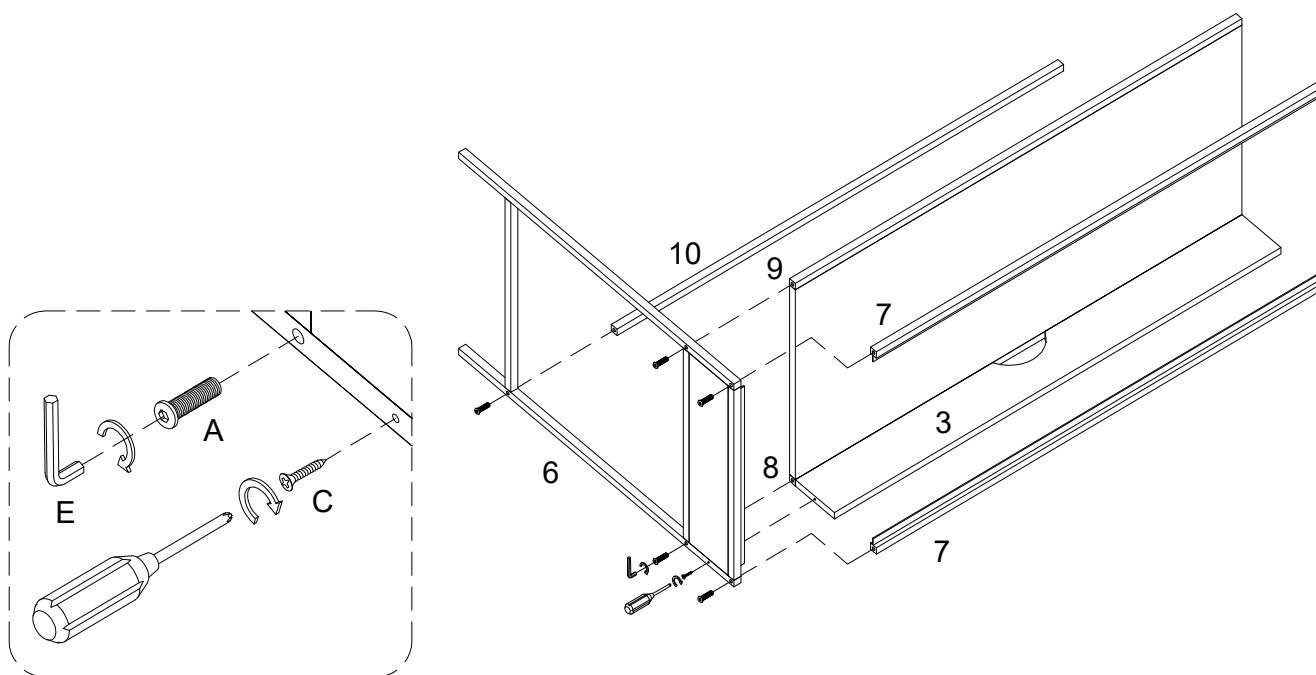

Attach part (6) to part (3,7,8,9,10) using bolt (A) with hex key (E) and screw (C) with screwdriver.

Step 9

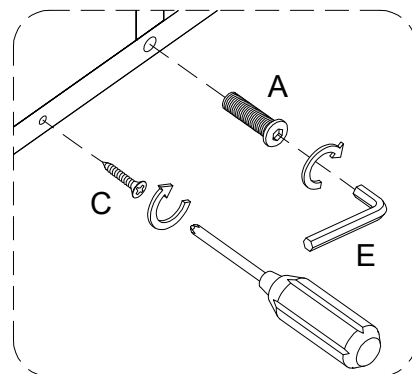
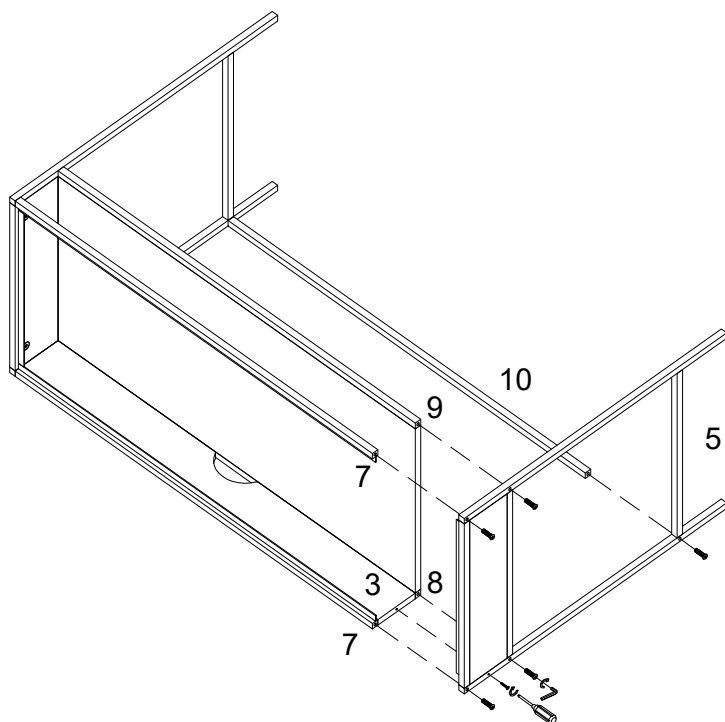

Attach part (5) to part (3,7,8,9,10) using bolt (A) with hex key (E) and screw (C) with screwdriver.

Step 10

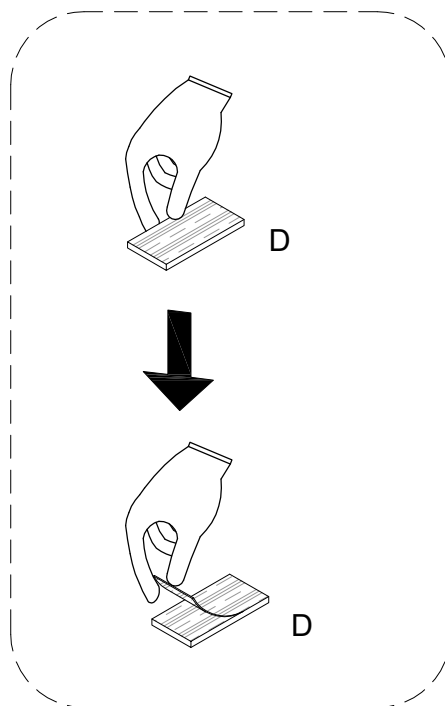
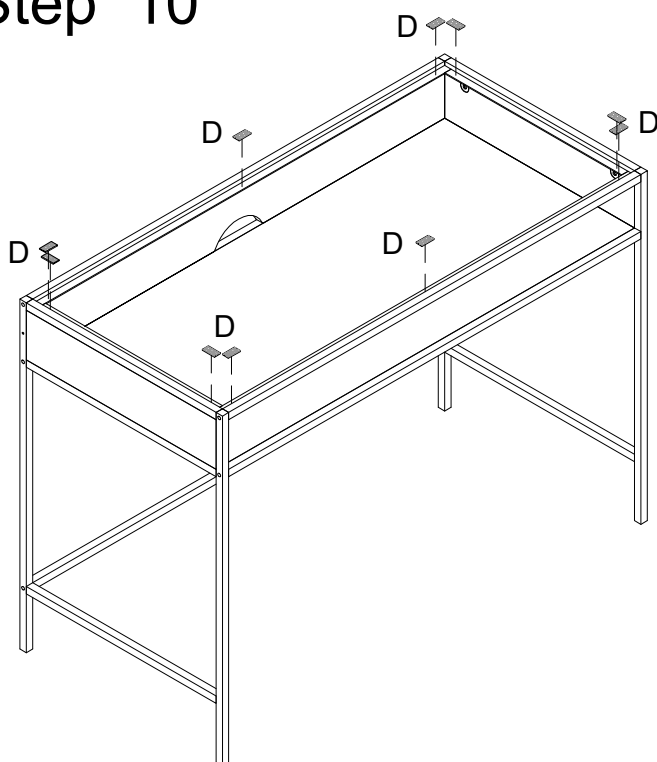

Remove cover tape on glass pads (D), then stick it as diagram.

Step 11

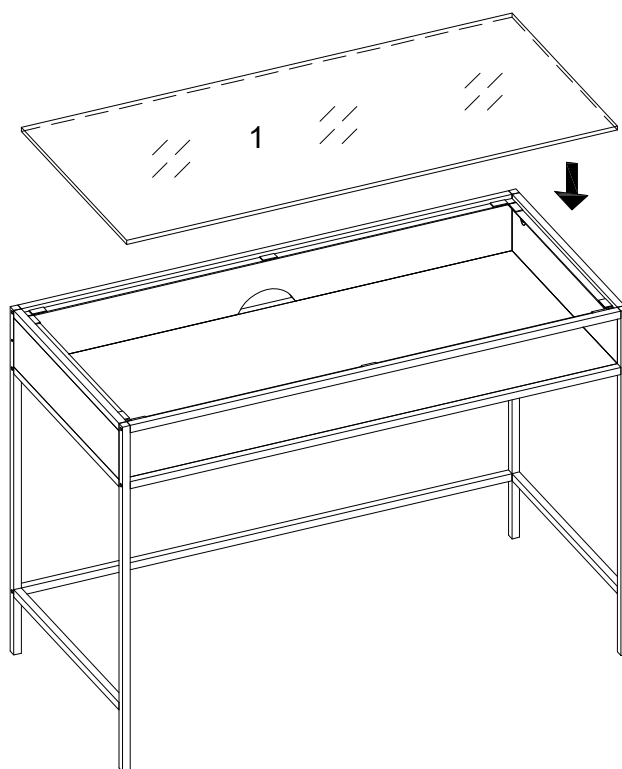

Place Glass (1) into desk frame carefully as per diagram.

Step 12

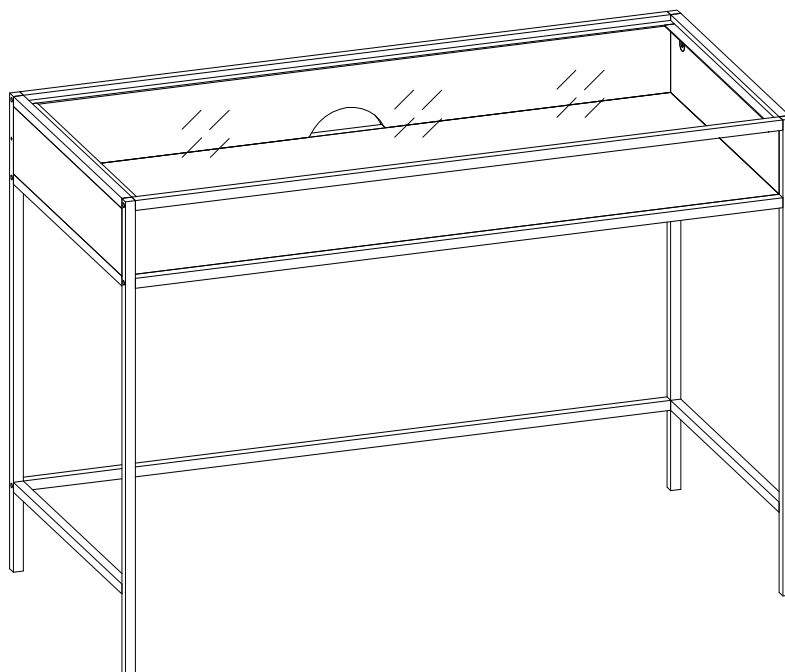

Final Assembly