

Introduction

Thank you for choosing our floor lamp. Please read this user manual carefully and keep it for future reference, if you need any assistance, please contact us with your order number and details.

Package Contents

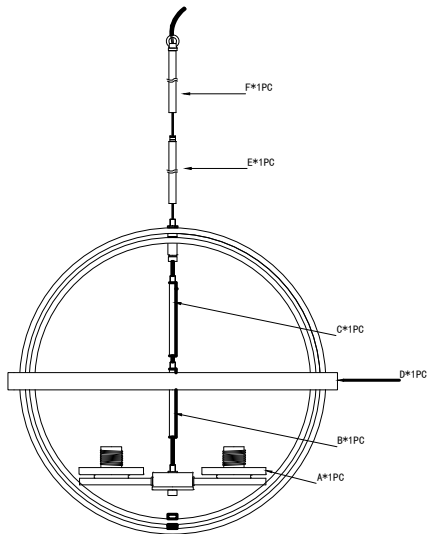
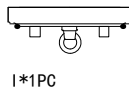
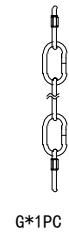
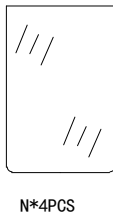
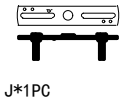

Product Structure (inch)

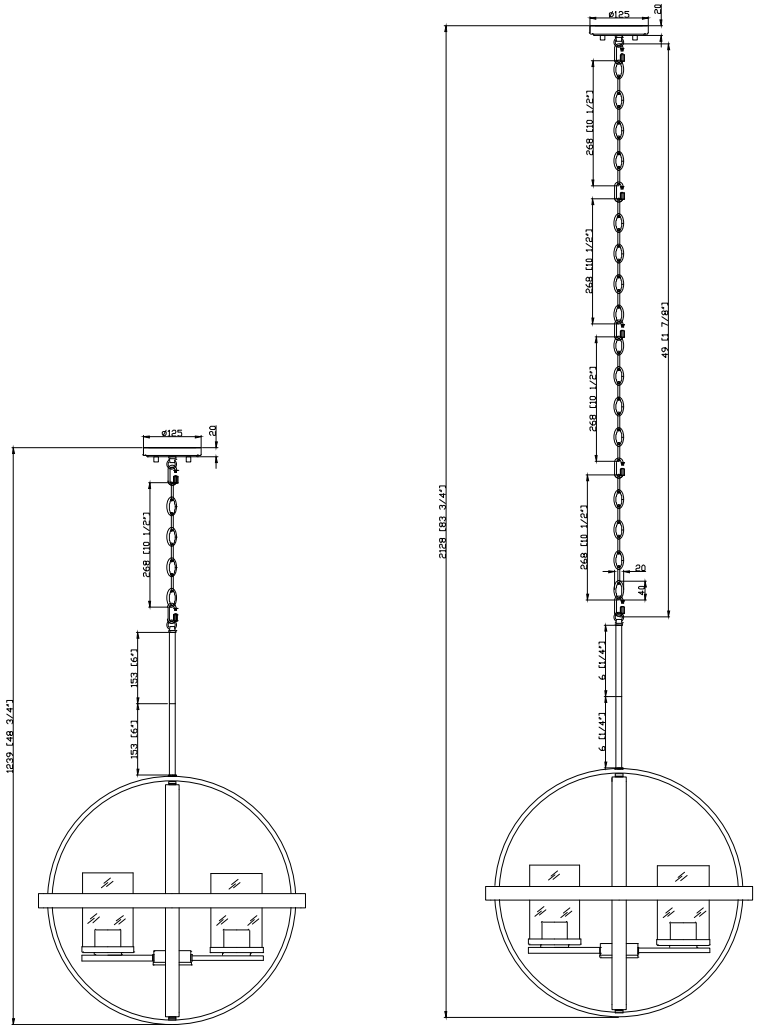

Introduction

WARNING:

1. It is highly recommended that all hardwired fixtures be installed by a professional electrician.
2. To reduce the risk of fire, electrical shock, or personal injury, always turn off the light fixture and let it cool before replacing light bulbs.
3. Do not touch the bulb when the fixture is turned on. Do not look directly at a lit bulb.
4. Keep flammable materials away from a lit bulb.
5. Shut off all main electrical supply from the fuse box/circuit breaker.
6. Use an E26 bulb with a maximum wattage of 60 watts. Do not exceed the recommended wattage.

Installation Steps:

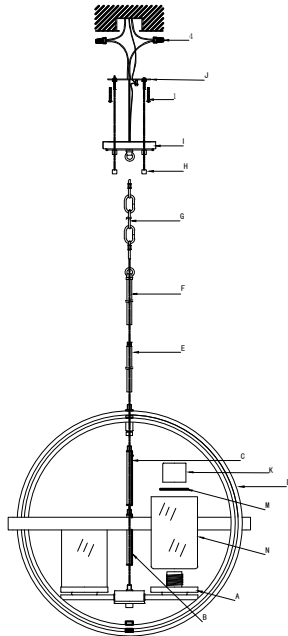

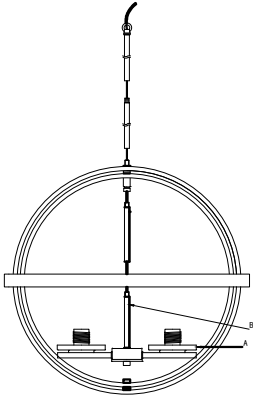

Step 1-Connect B to A.

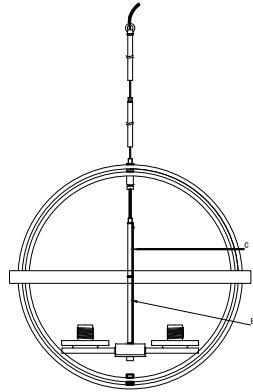

Step 2-Connect C to B.

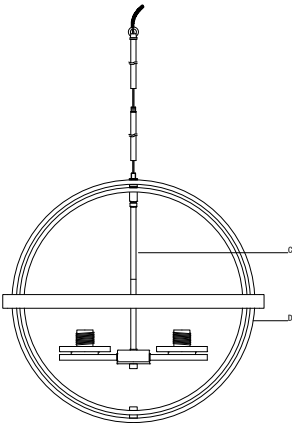

Step 3-Connect C to D.

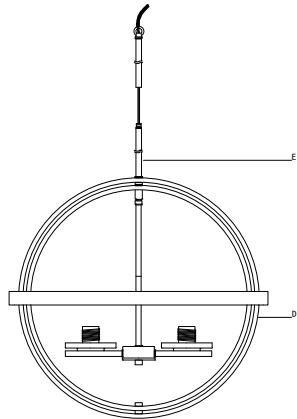

Step 4-Connect E to D.

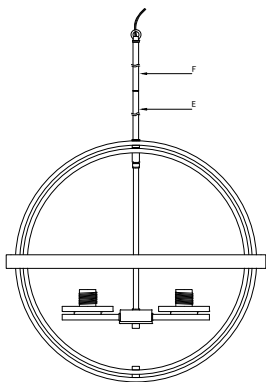

Step 5-Connect F to E.

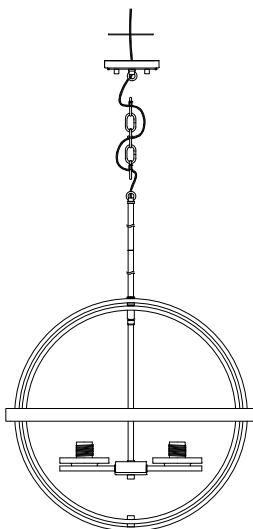

Step 6-Thread the wire from D through G, I, and J.

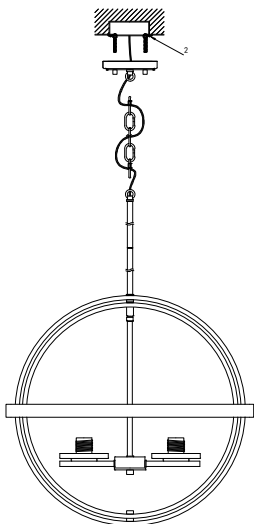

Step 7-Use screw #2 to secure J to the junction box inside the wall.

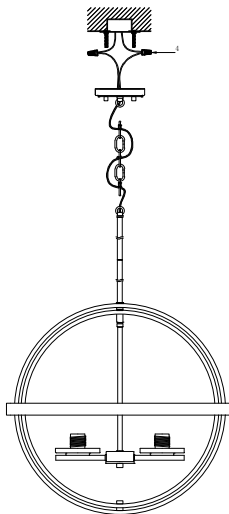

Step 8-Connect the wires properly by following the positive and negative terminals.

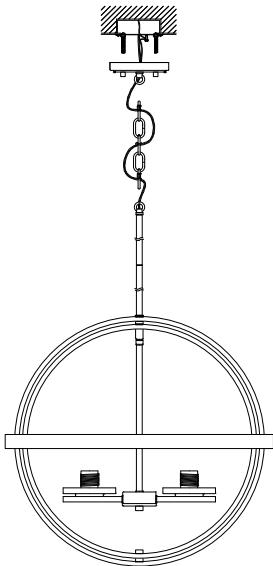

Step 9-Use the green screw to secure the ground wire to J.

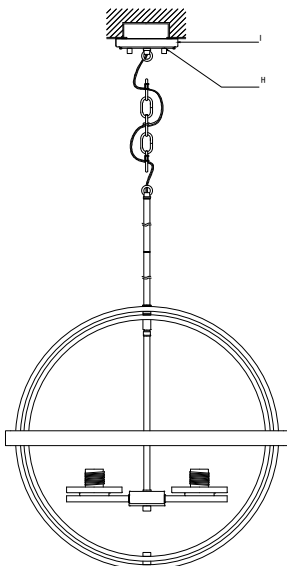

Step 10-Connect H to J and secure I to the wall.

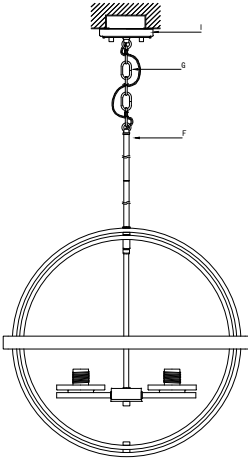

Step 11-Connect G to both F and L.

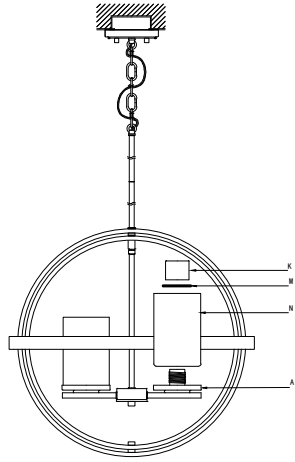

Step 12-Use K to secure M and N to A.



Made In China

RoHS



Instrumk
5015610