

ASSEMBLY INSTRUCTIONS



Fine Furniture for every stage of life

Dining Table

ASSEMBLY INSTRUCTIONS

ASSEMBLY TIPS:

1. Remove hardware from box and sort by size.
2. Please check to see that all hardware and parts are present prior to start of assembly.
3. Please follow attached instructions in the same sequence as numbered to assure fast & easy assembly.



WARNING!

1. Don't attempt to repair or modify parts that are broken or defective. Please contact the store immediately.
2. This product is for home use only and not intended for commercial establishments.



ASSEMBLY TIME

20 MINUTES

PARTS IDENTIFICATION

B1 (BOX 1)

A TOP

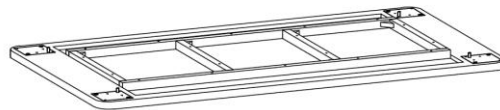

1PC

B MOUNTING PLATE
(ATTACHED TO TOP)

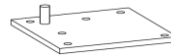

4PCS

B2 (BOX 2)

C LEG



4PCS

HARDWARE IDENTIFICATION

(BOX 1) - HARDWARE PACK IS LOCATED IN (B1)

1 ALLEN WRENCH
(M4 x 100mm - BLK)



1PC

2 BOLT
(M6 x 25mm - BLK)



16PCS

3 LOCK WASHER
(M6 - BLK)



4PCS

4 FLAT WASHER
(M6 - BLK)



4PCS

ASSEMBLY INSTRUCTIONS

STEP 1

Attention! Please remove part B and all hardware from TOP (A), using ALLEN WRENCH (1) and keep for STEP 3.

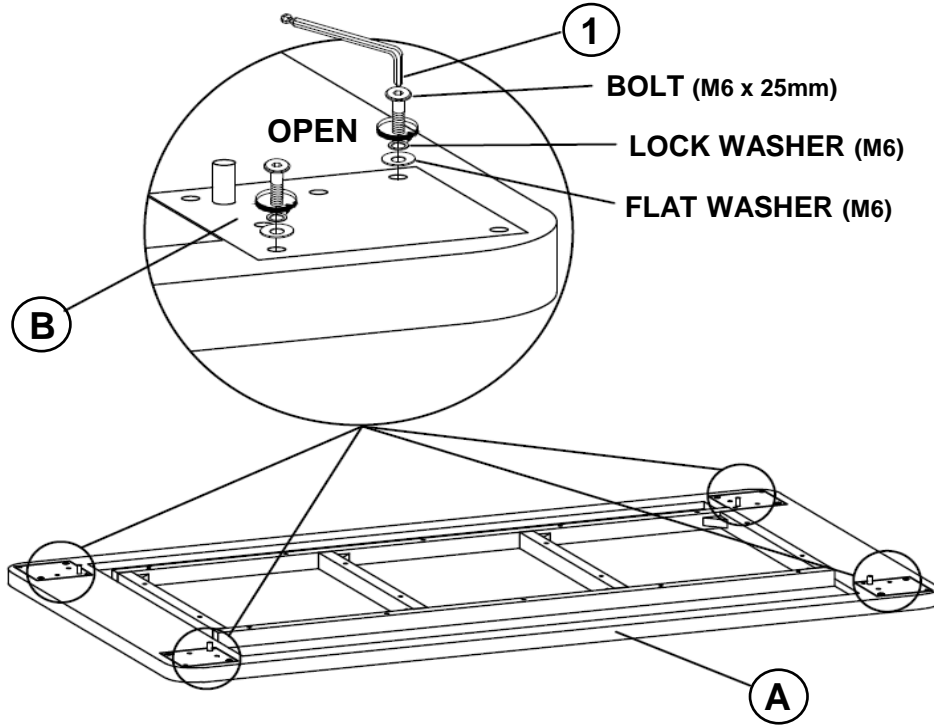

STEP 2

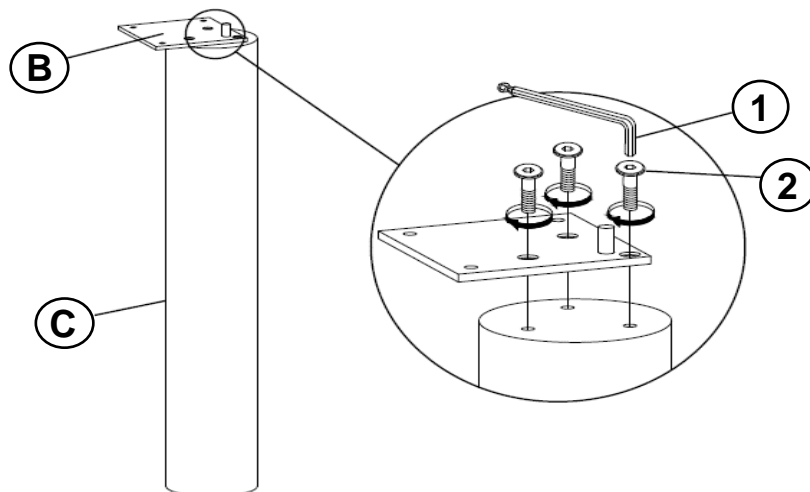

ASSEMBLY INSTRUCTIONS

STEP 3

Attention! Use hardware from STEP 1 for this STEP.

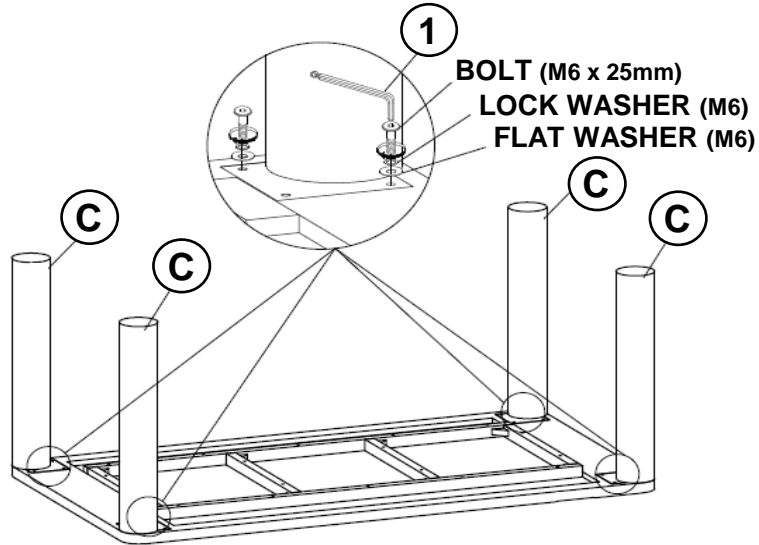

STEP 4

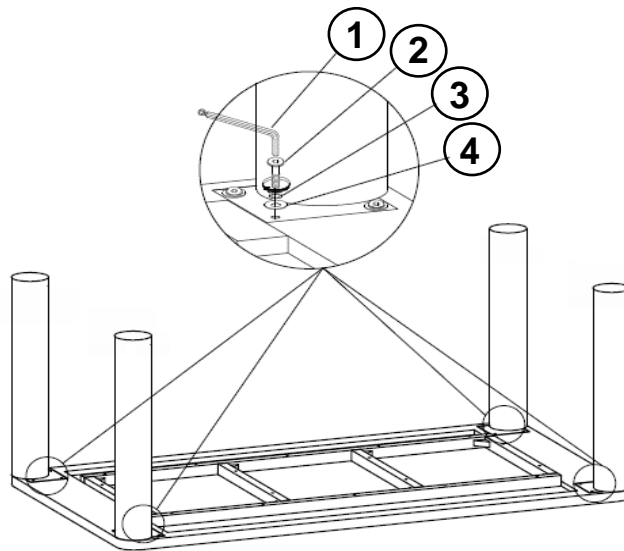

STEP 5

COMPLETE

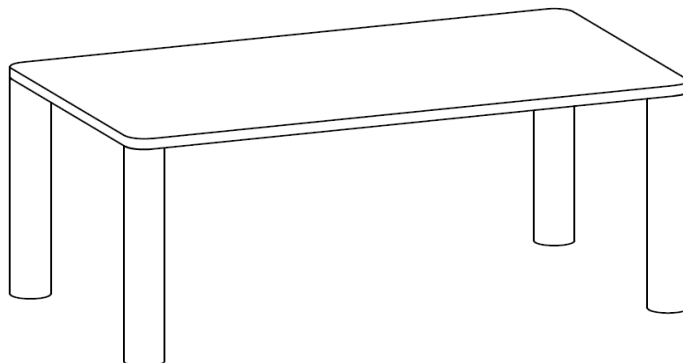

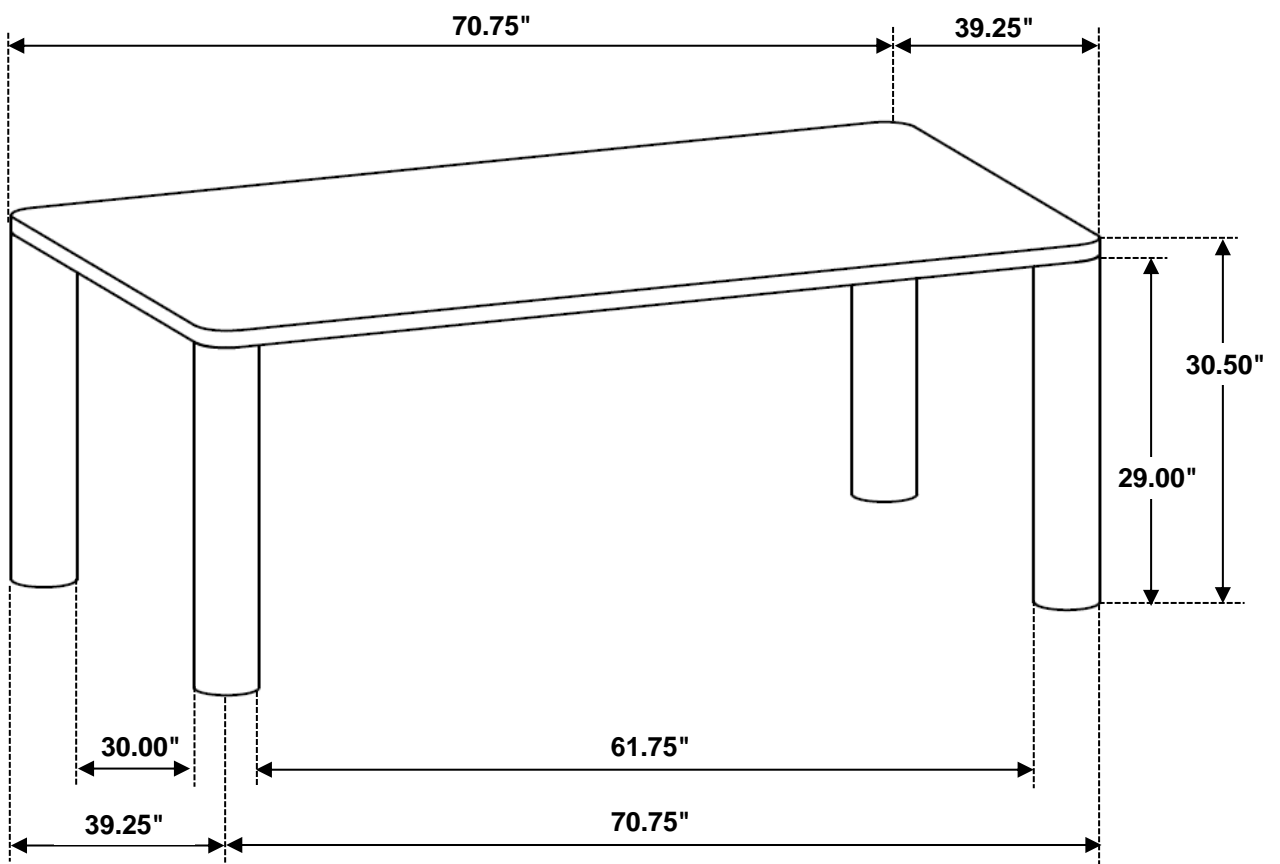

Note: Dimension tolerance $\pm 5\%$

ASSEMBLY INSTRUCTIONS



Fine Furniture for every stage of life

ASSEMBLY INSTRUCTIONS

ASSEMBLY TIPS:

1. Remove hardware from box and sort by size.
2. Please check to see that all hardware and parts are present prior to start of assembly.
3. Please follow attached instructions in the same sequence as numbered to assure fast & easy assembly.



WARNING!

1. Don't attempt to repair or modify parts that are broken or defective. Please contact the store immediately.
2. This product is for home use only and not intended for commercial establishments.

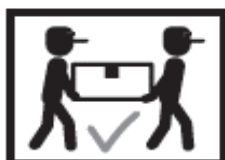

ASSEMBLY TIME

10 MINUTES

PARTS IDENTIFICATION

A SEAT AND BACK



1PC

B FRONT LEG



2PCS

C BACK LEG

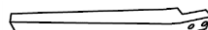

2PCS

HARDWARE IDENTIFICATION

1 ALLEN WRENCH
(M4 x 100mm - BLK)



1PC

2 SHORT BOLT
(M6 x 40mm - RBW)



4PCS

3 LONG BOLT
(M6 x 60mm - RBW)

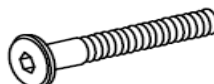

4PCS

4 LOCK WASHER
(M6 - RBW)



8PCS

5 FLAT WASHER
(M6 - RBW)



8PCS

NOTE:

Quantities shown are for one chair.

ASSEMBLY INSTRUCTIONS

STEP 1

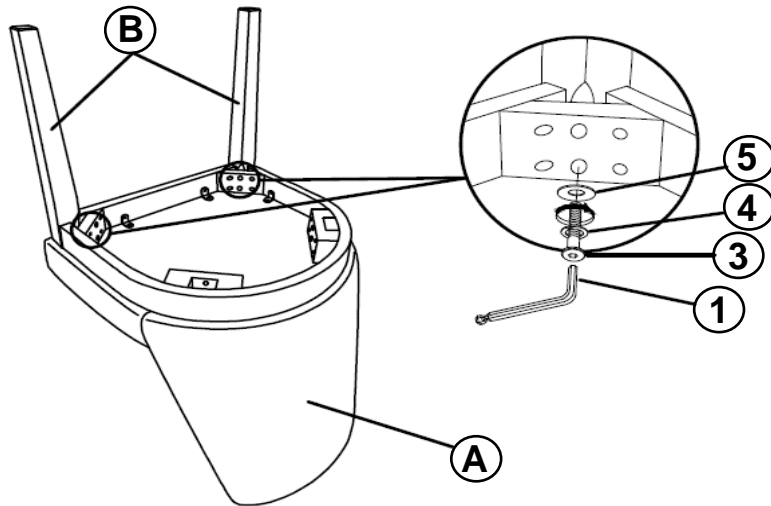

STEP 2

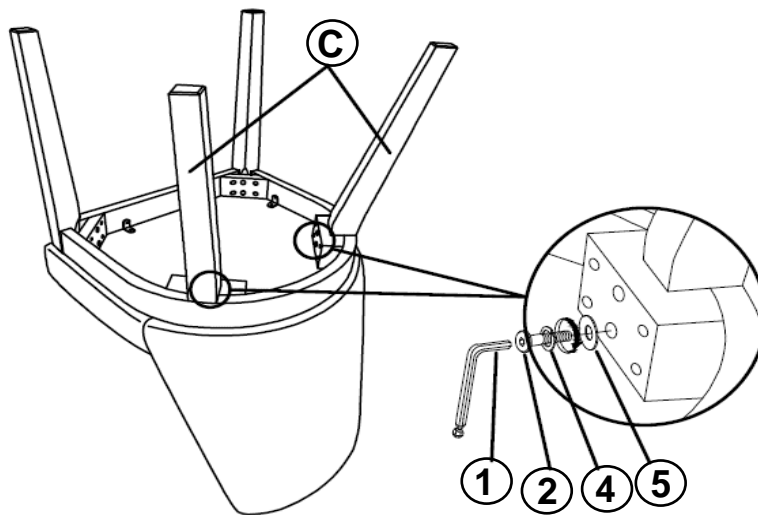

STEP 3

COMPLETE

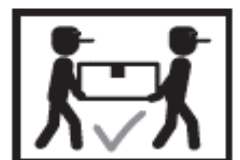
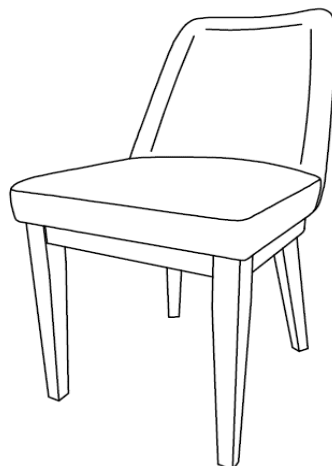

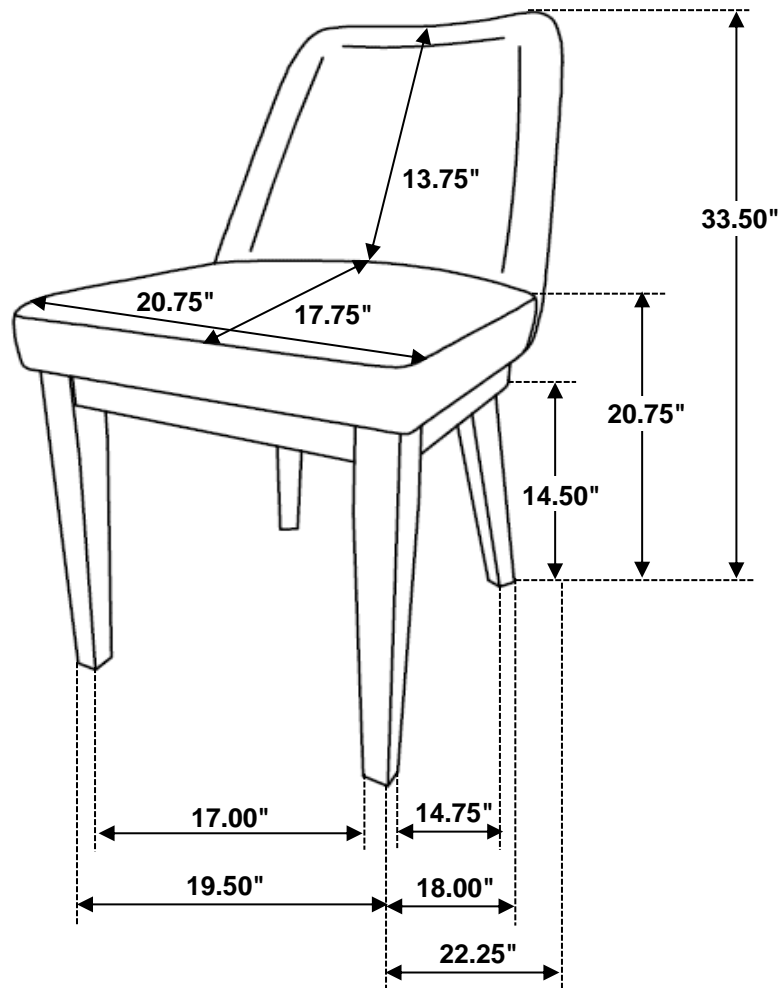

Note: Dimension tolerance $\pm 5\%$