

ASSEMBLY INSTRUCTIONS



Fine Furniture for every stage of life

OFFICE DESK

REVISION 0 : 09/26/2017
REVISION 1 : 06/04/2018
REVISION 2 : 08/25/2018
REVISION 3 : 07/15/2019

REVISION 4 : 06/27/2022
REVISION 5 : 09/23/2022

PAGE 1 OF 13

ITEM:

ASSEMBLY INSTRUCTIONS

ASSEMBLY TIPS:

1. Remove hardware from box and sort by size.
2. Please check to see that all hardware and parts are present prior to start of assembly.
3. Please follow attached instructions in the same sequence as numbered to assure fast & easy assembly.



WARNING!

1. Don't attempt to repair or modify parts that are broken or defective. Please contact the store immediately.
2. This product is for home use only and not intended for commercial establishments.

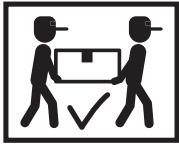

ASSEMBLY TIME

80 MINUTES





PARTS IDENTIFICATION

| | | | | | | | |
|---|------------------------------|--|------|---|-------------------------------|--|-------|
| A | LARGE LEFT SIDE PANEL | | 1 PC | I | LARGE RIGHT DRAWER SIDE PANEL | | 1 PC |
| B | LARGE RIGHT SIDE PANEL | | 1 PC | J | SMALL DRAWER BOTTOM PANEL | | 2 PCS |
| C | SMALL BOTTOM PANEL | | 1 PC | K | SMALL DRAWER FRONT PANEL | | 2 PCS |
| D | TOP DRAWER PANEL | | 1 PC | L | SMALL DRAWER BACK PANEL | | 2 PCS |
| E | BACK PANEL | | 1 PC | M | SMALL LEFT DRAWER SIDE PANEL | | 2 PCS |
| F | LARGE DRAWER FRONT PANEL | | 1 PC | N | SMALL RIGHT DRAWER SIDE PANEL | | 2 PCS |
| G | LARGE DRAWER BACK PANEL | | 1 PC | O | SMALL LEFT SIDE PANEL | | 1 PC |
| H | LARGE LEFT DRAWER SIDE PANEL | | 1 PC | P | SMALL RIGHT SIDE PANEL | | 1 PC |



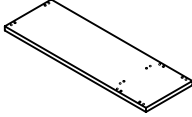

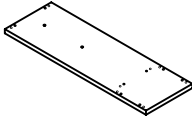
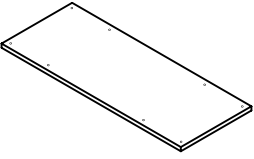
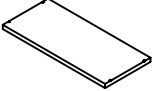

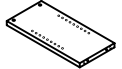
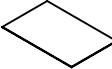



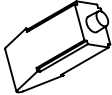
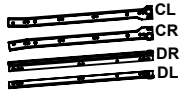
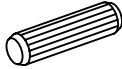



NOTE:

Phillips head screw driver is required in the assembly process; however, manufacturer does not provide this item.

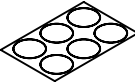
ITEM:

| | | | | | | | |
|---|------------------------|---|-------|----|----------------------------------|---|-------|
| Q | LARGE BOTTOM PANEL |  | 1 PC | U | SMALL ADJUSTABLE PANEL |  | 2 PCS |
| R | MIDDLE TOP PANEL |  | 1 PC | V | LARGE TOP PANEL |  | 1 PC |
| S | LARGE ADJUSTABLE PANEL |  | 1 PC | A1 | LARGE TOP PANEL PARTITION BOARDS |  | 2 PCS |
| T | DIVIDER PANEL |  | 2 PCS | B1 | LARGE DRAWER BOTTOM PANEL |  | 1 PC |

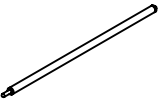
HARDWARE IDENTIFICATION

| Z | HARDWARE IDENTIFICATION | | | | | | |
|----|--|---|--------|----|--------------------------------|---|--------|
| NO | DESCRIPTION | FIGURE | Q'TY | NO | DESCRIPTION | FIGURE | Q'TY |
| 1 | GLUE 40g |  | 1 PC | 10 | SAMLL RAIL L = 400mm WHT |  | 2 SET |
| 2 | WOODEN DOWEL Ø 8x30mm |  | 34 PCS | 11 | SHORT SCREW Ø 3x12mm SR |  | 42 PCS |
| 3 | CAM BOLT Ø 7x35.5mm SR |  | 18 PCS | 12 | FOOT 50x50x18mm |  | 9 PCS |
| 4 | CAM LOCK Ø 15x12mm SR |  | 18 PCS | 13 | SCREW FOR FOOT Ø 5x23mm BLK |  | 18 PCS |
| 5 | LONG SCREW Ø 4.3x35mm SR |  | 20 PCS | 14 | SHORT BOLT M6x42mm SR |  | 4 PCS |
| 6 | LONG BOLT Ø 9.5x55mm FOR BOTTOM PANEL SR |  | 14 PCS | 15 | STICKER Ø 20mm |  | 3 PCS |
| 7 | PIN Ø 4.9x8mm SR |  | 12 PCS | 16 | LARGE RAIL L = 450mm WHT |  | 1 SET |
| 8 | HANDLE L= 120mm |  | 3 PCS | 17 | IRON BAR Ø 9.5x289.5mm SR |  | 2 PCS |
| 9 | HANDLE BOLT Ø 4x28mm SR |  | 6 PCS | | | | |

Z8,Z9,Z10,Z12,Z16,Z17 not included in blister packaging.

ITEM:

STEP 3

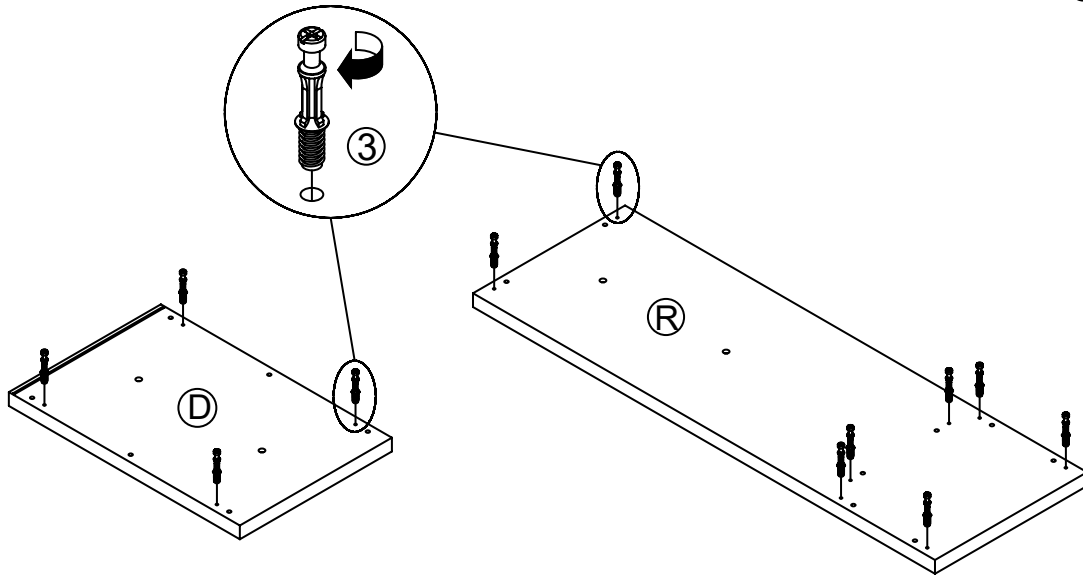
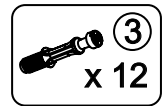

STEP 4

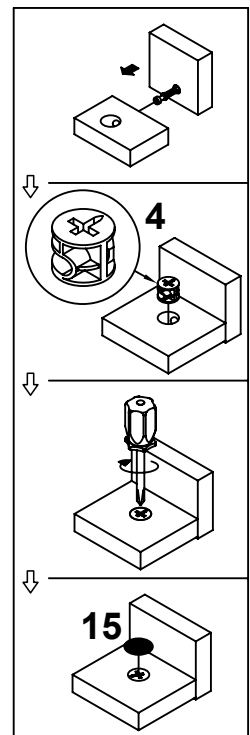
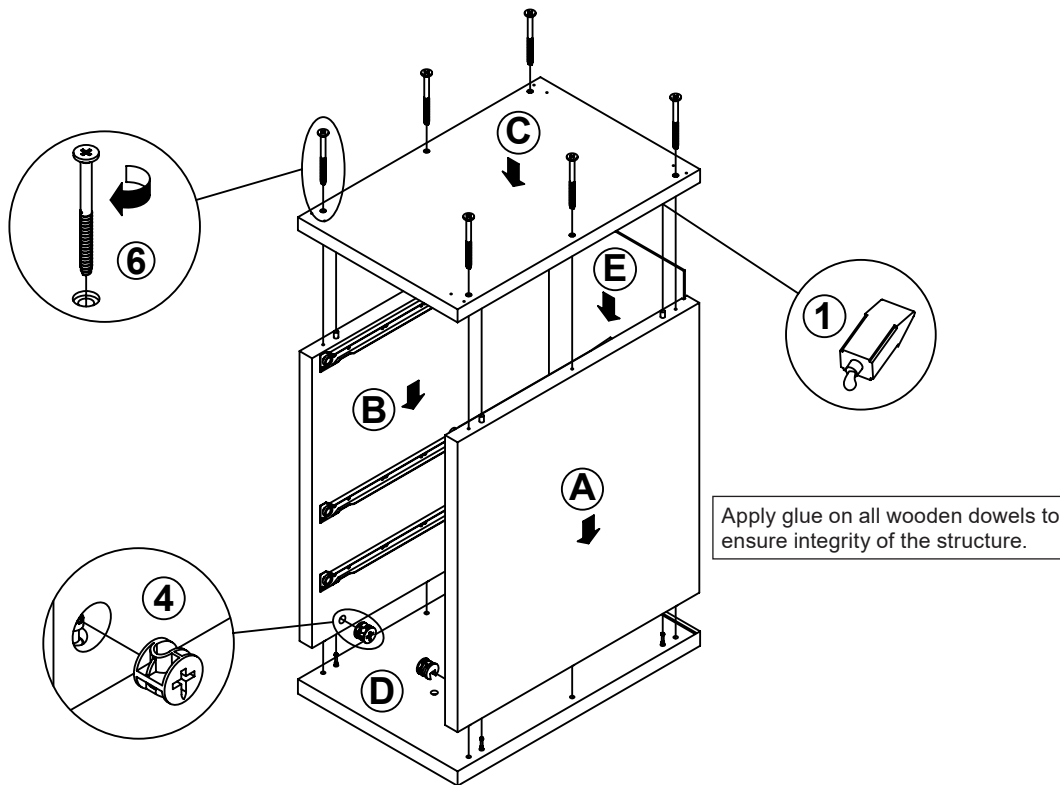
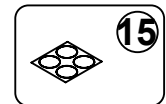
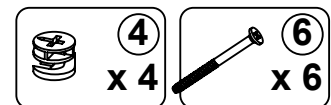

ITEM:

STEP 5

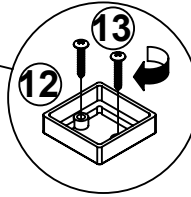
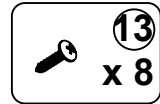
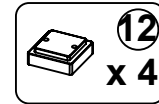
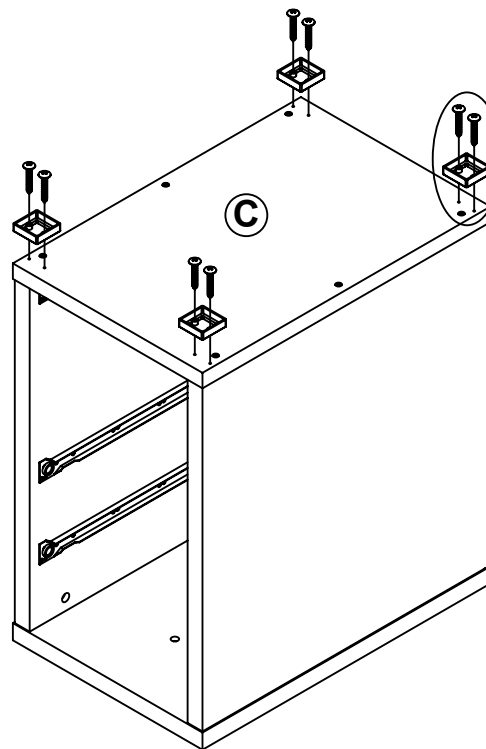

STEP 6

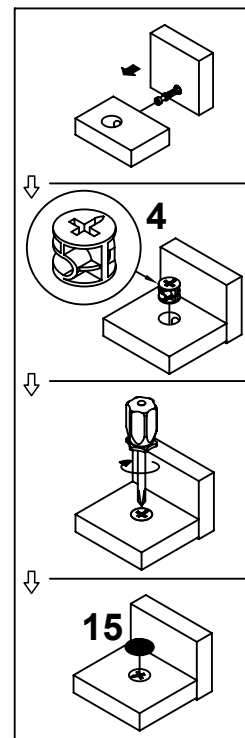
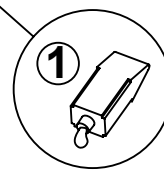
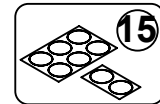
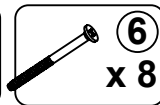
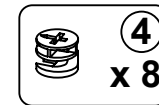
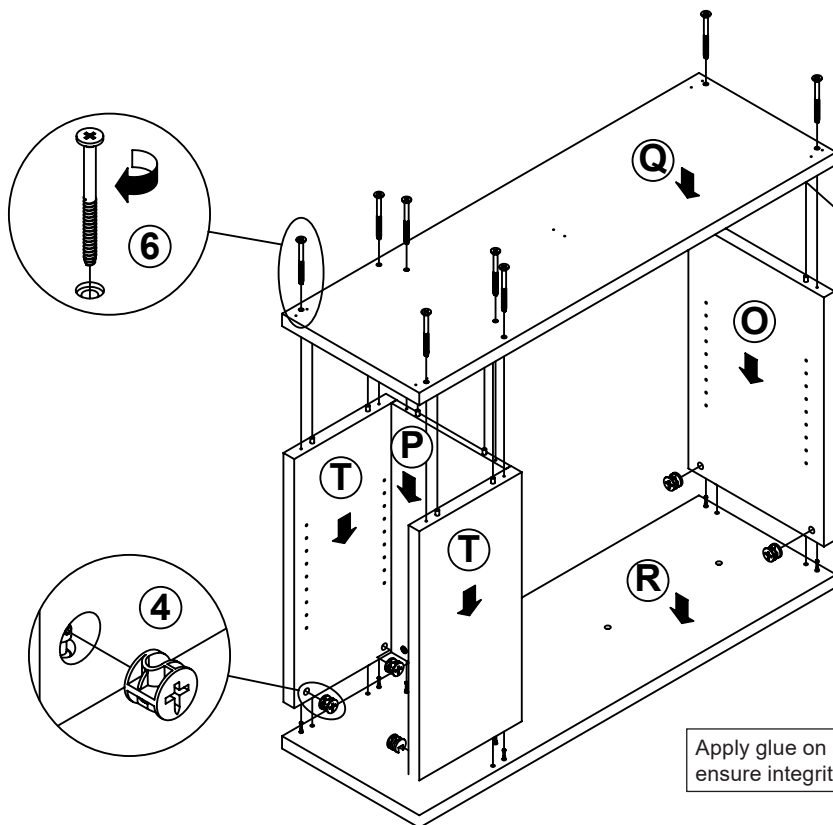

Apply glue on all wooden dowels to ensure integrity of the structure.

ITEM:

STEP 7

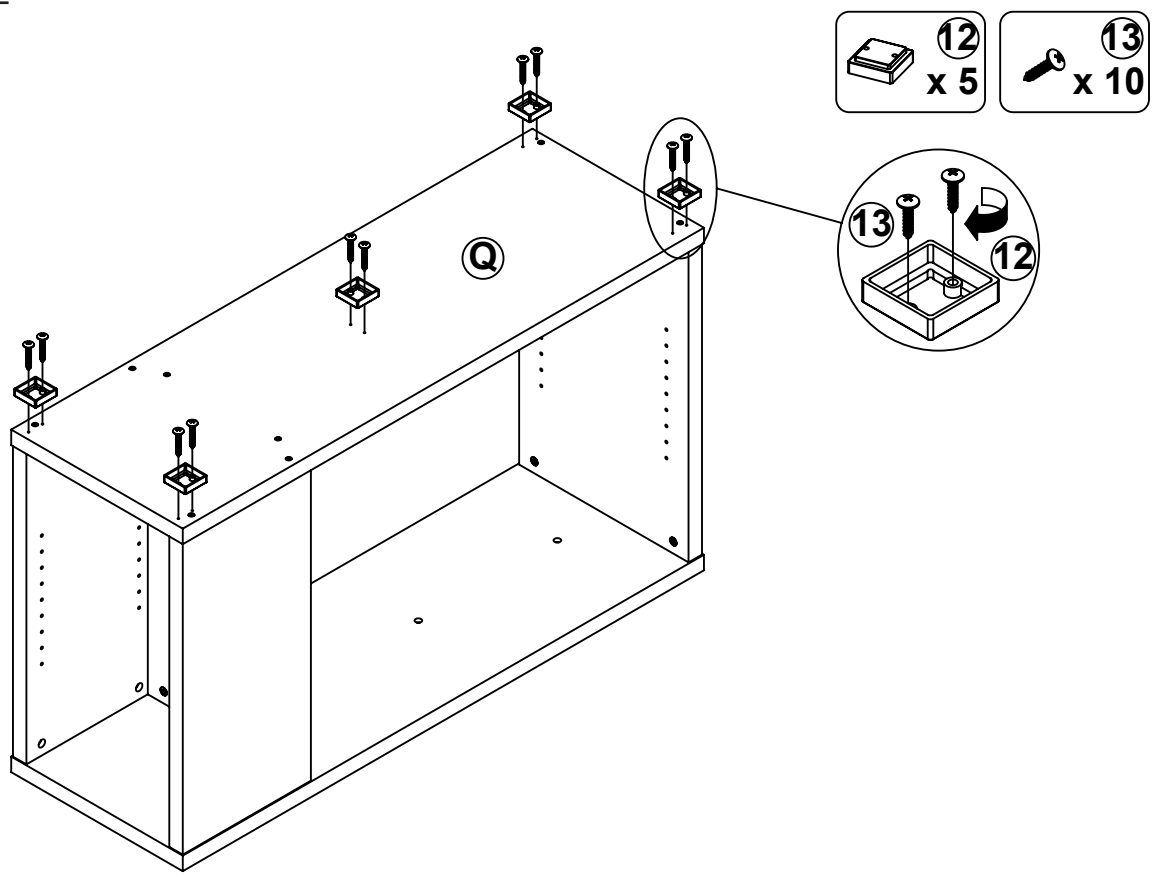

STEP 8

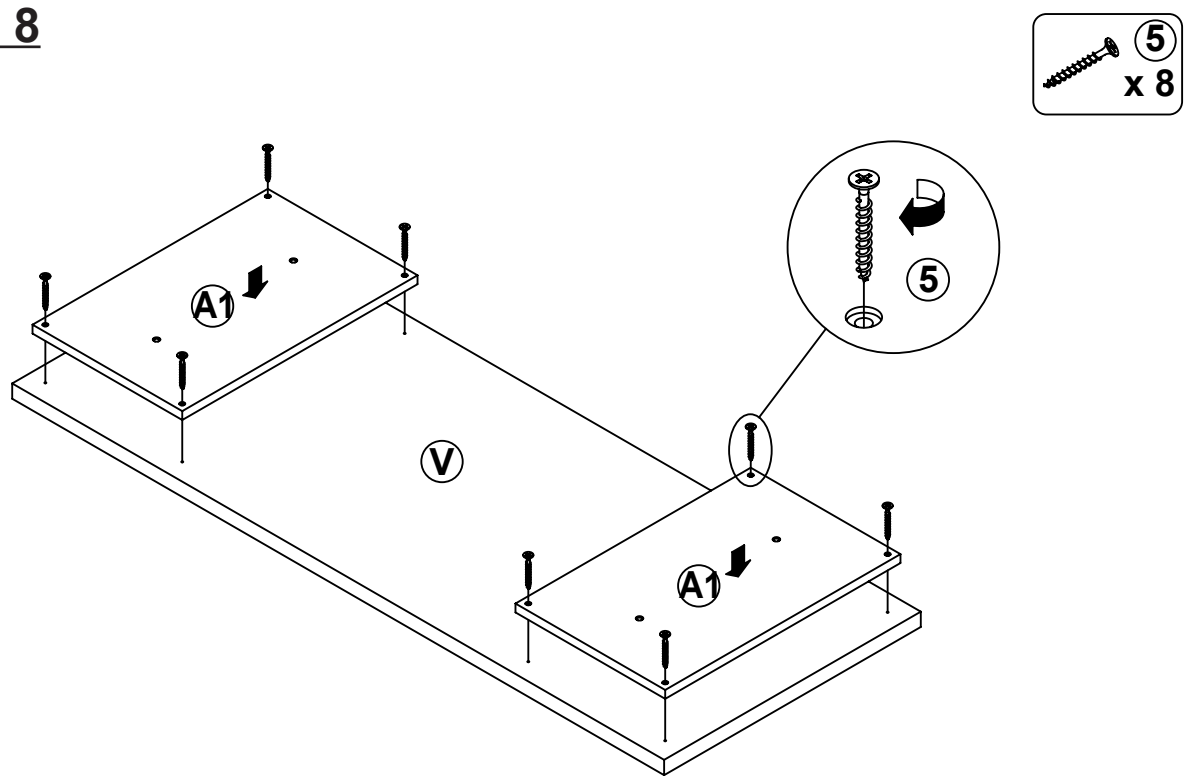

ITEM:

STEP 9

LEFT

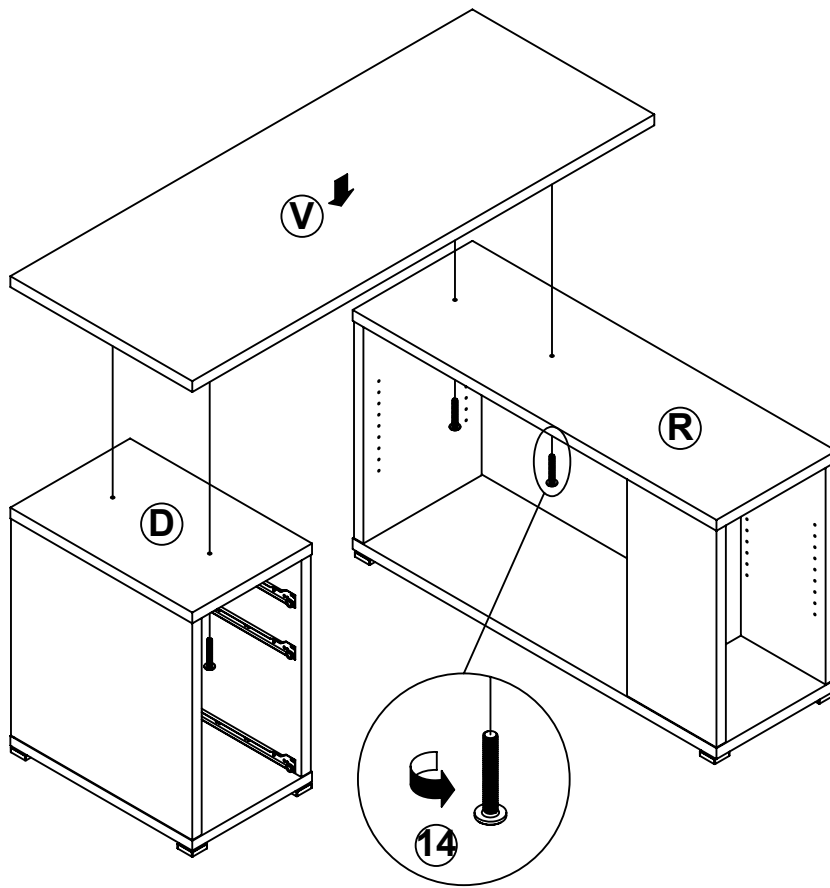
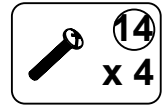

RIGHT

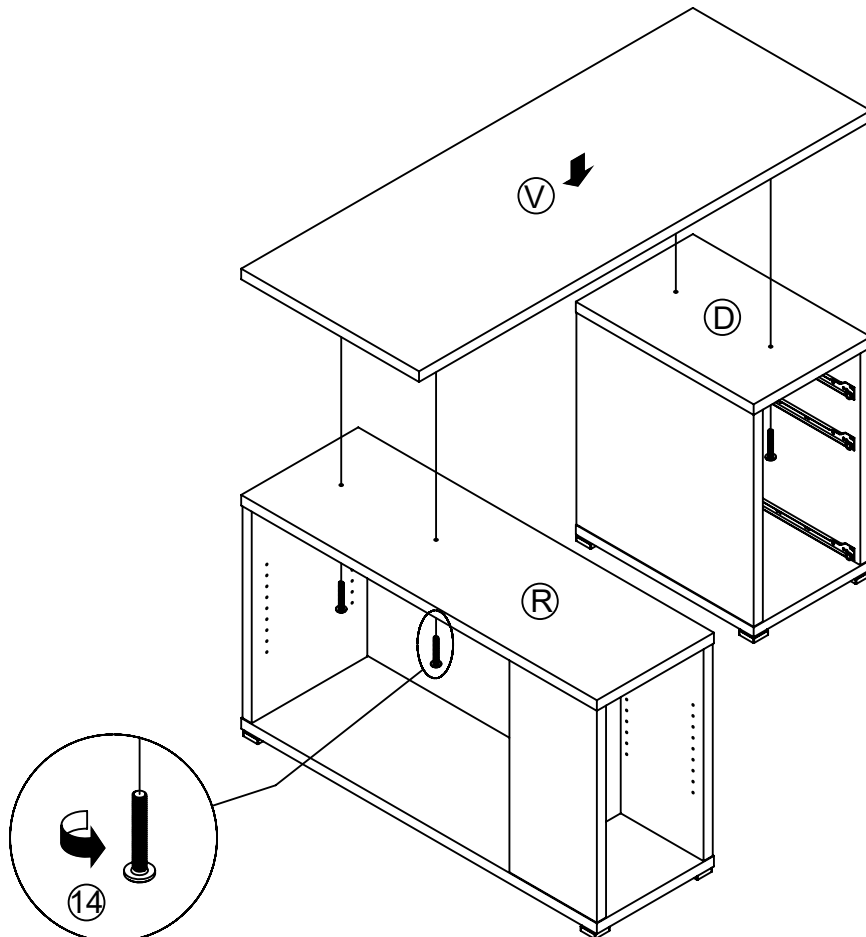

ITEM:

STEP 10

LEFT

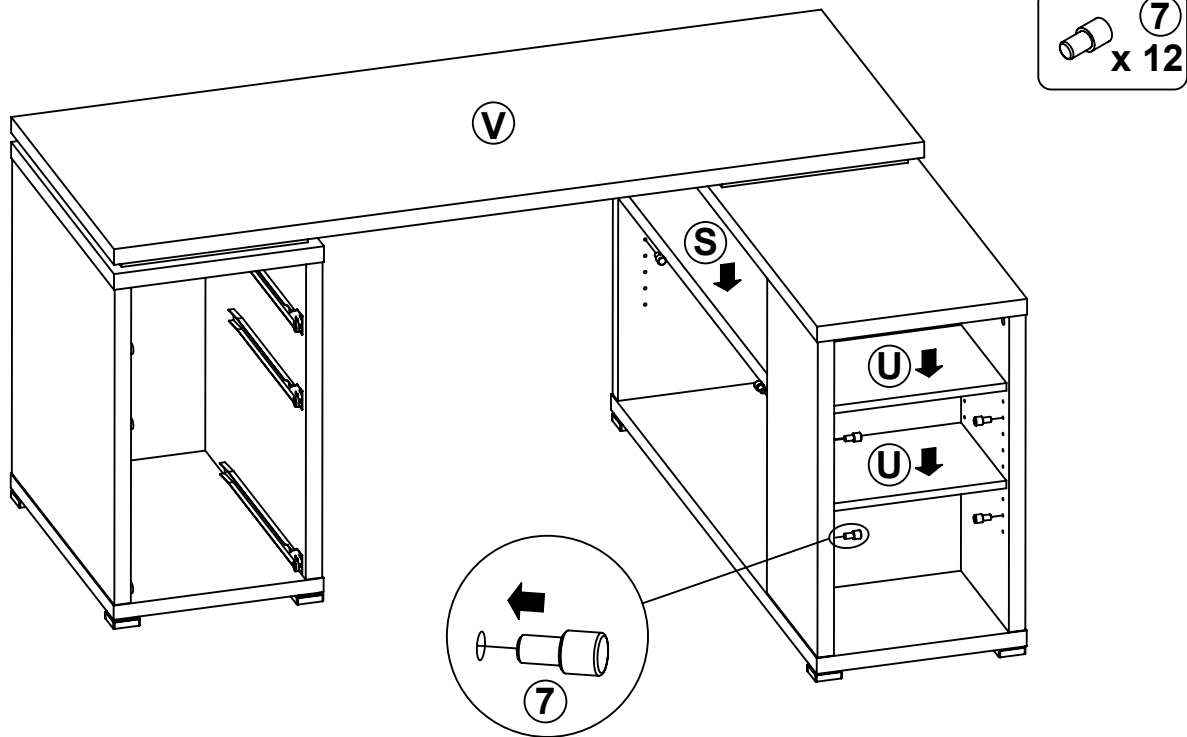

RIGHT

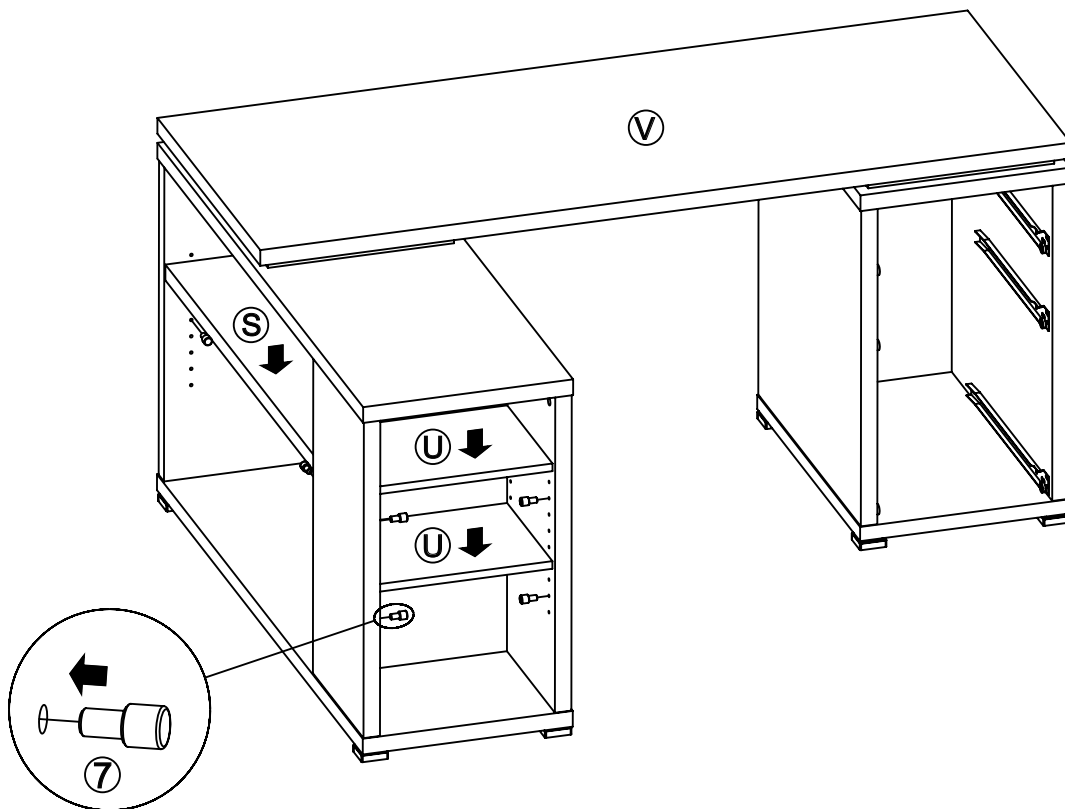

ITEM:

STEP 11

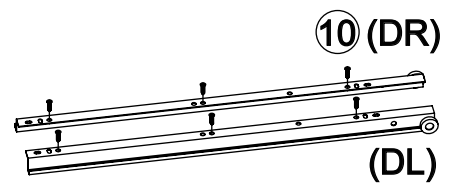
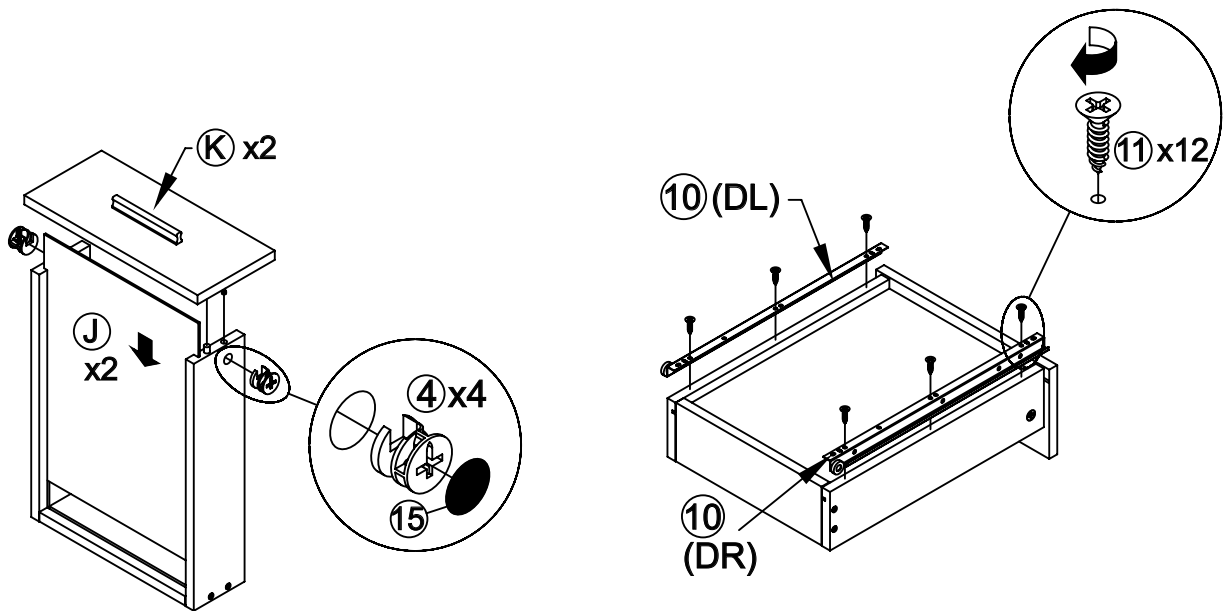
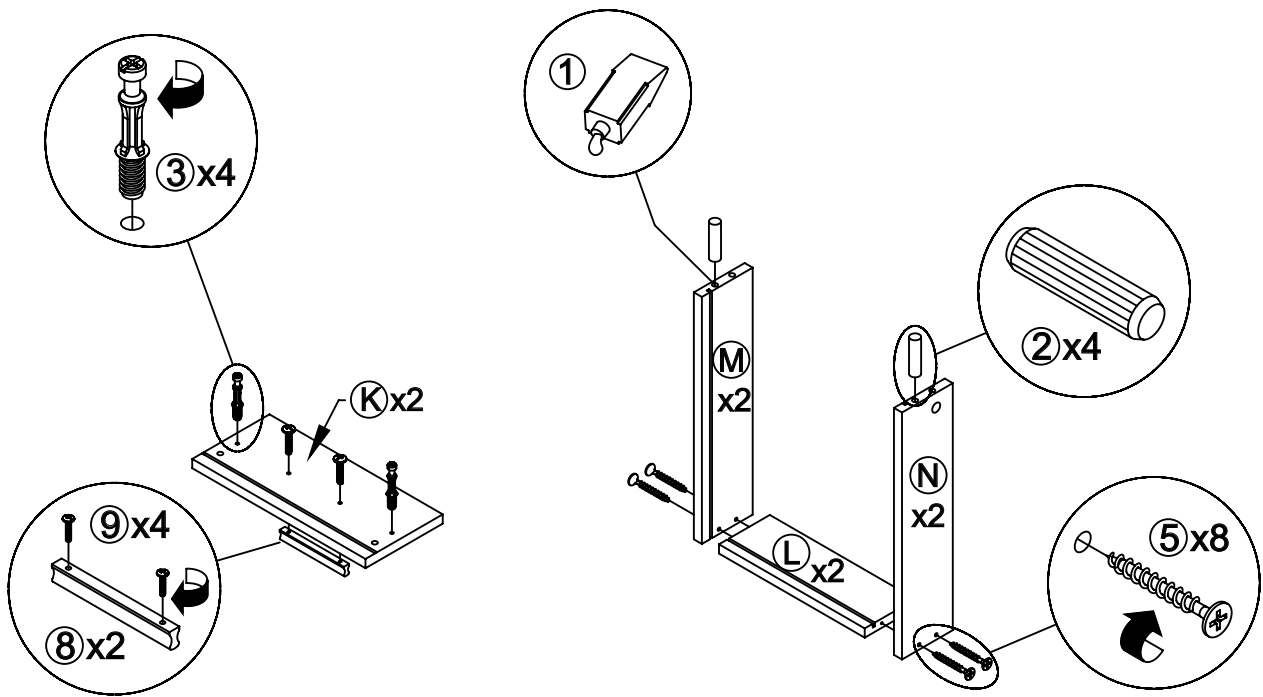

ITEM:

STEP 12

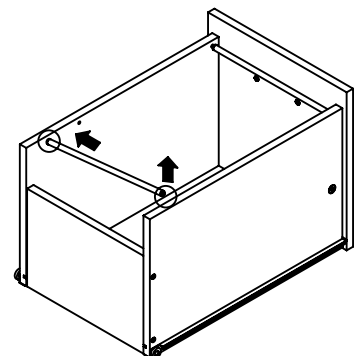
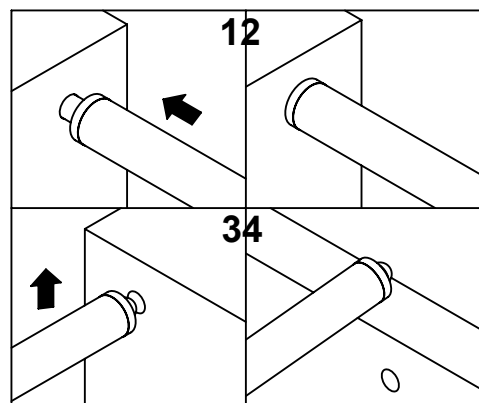
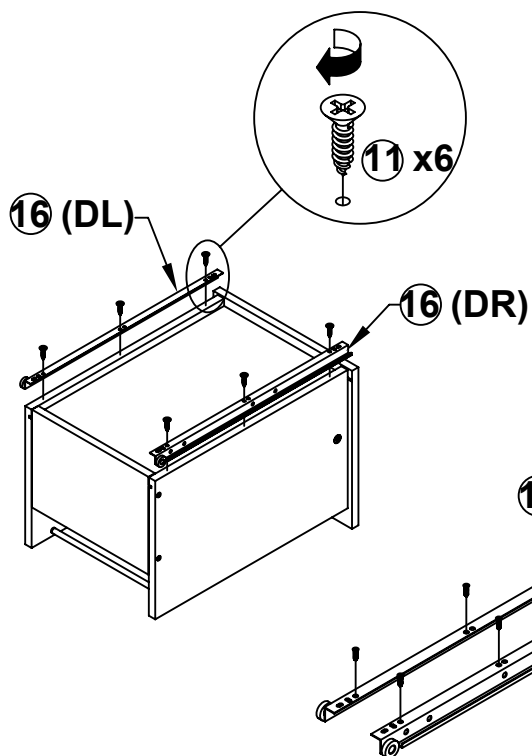
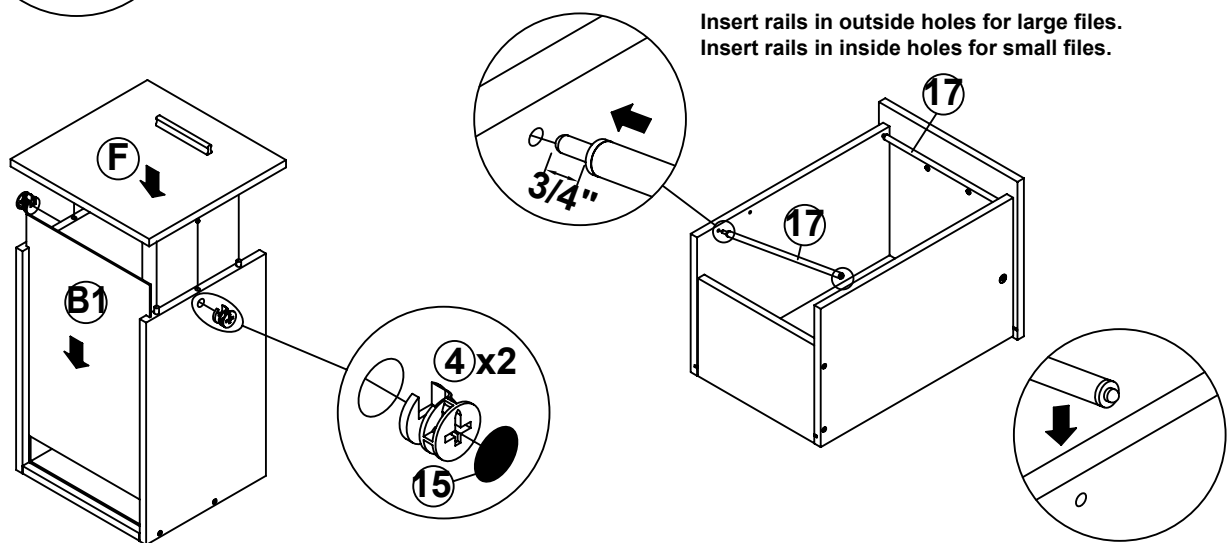
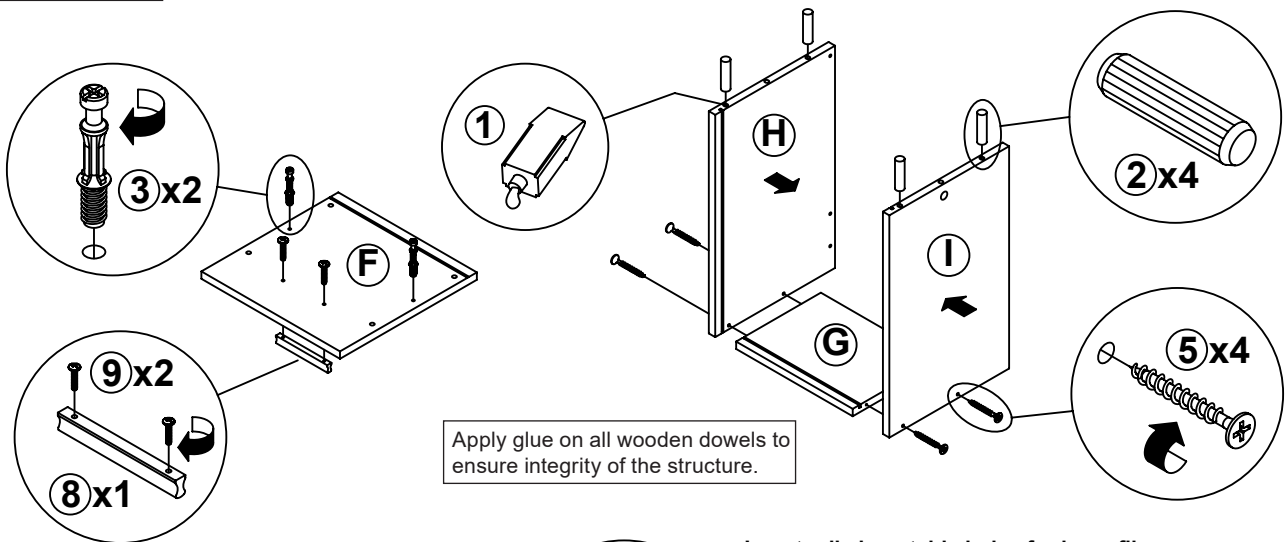

ITEM:

STEP 13
LEFT

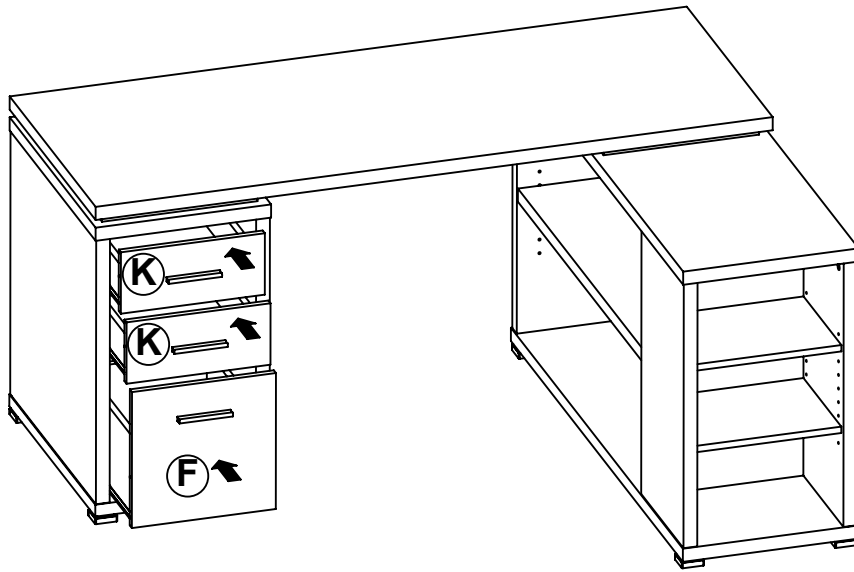

RIGHT

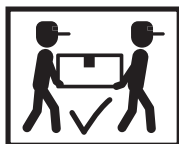
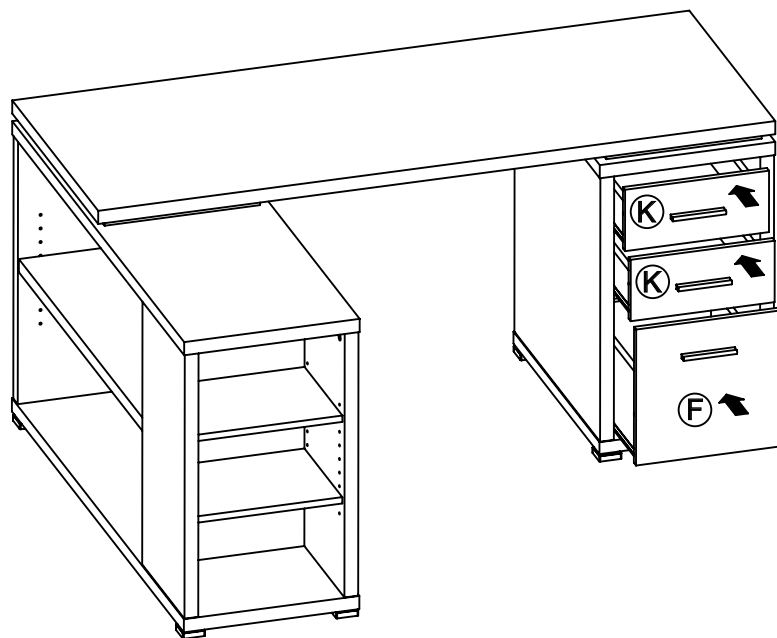

ITEM:

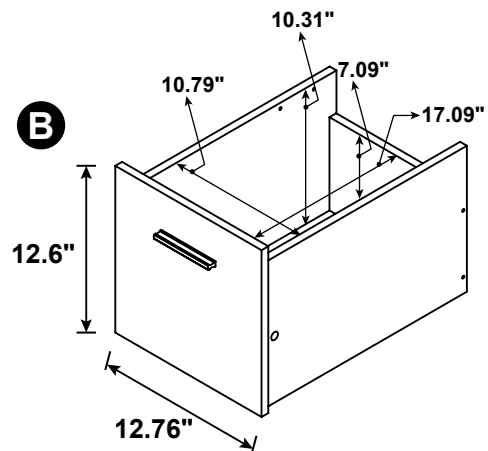
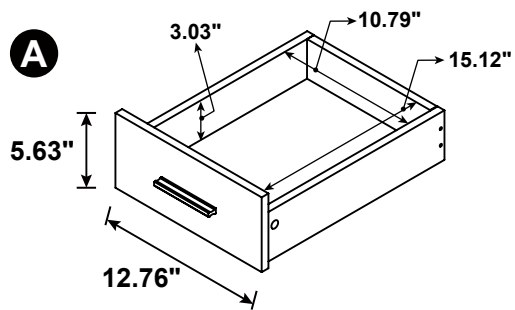
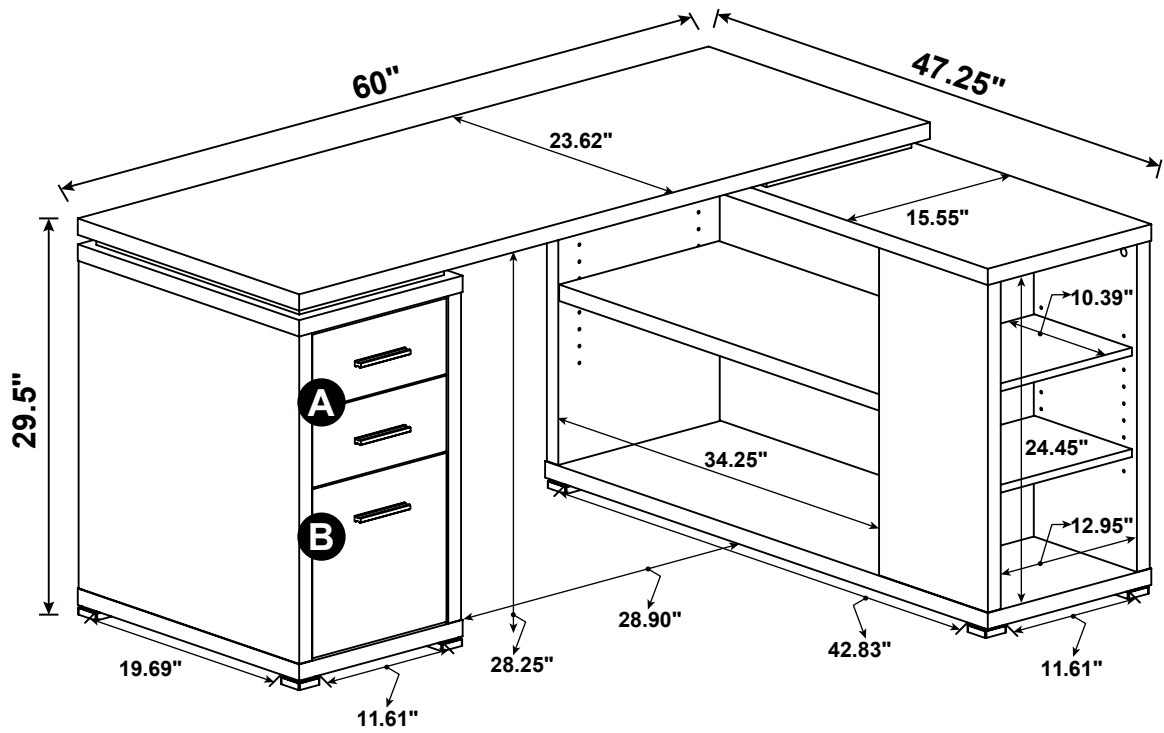

Note : Dimension tolerance $\pm 5\%$