

# Dresser with 4 Drawers

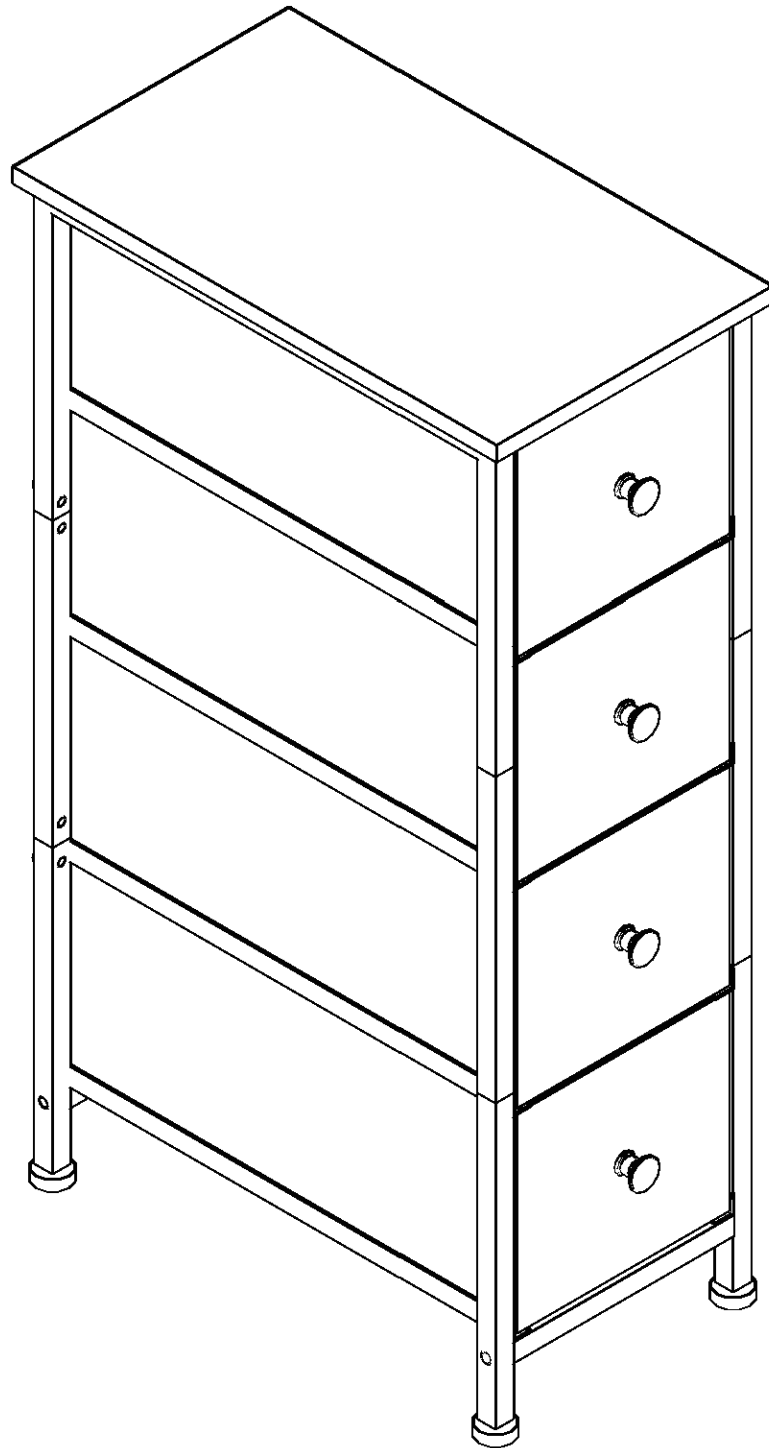

# PRE-ASSEMBLY PREPARATION

## Before you start:

1. Choose a clean, level, spacious assembly area. Avoid hard surfaces that may damage the product
2. Take care when lifting. Product should be assembled as near as possible to the point of use
3. Ensure that you have all required contents for complete assembly .
4. Always read the assembly instructions carefully before beginning assembly.
5. Keep all hardware parts and packaging out of reach of small children.
6. Do not over tighten the screws and bolts as this may damage the threads.

### Tools Needed (not included)

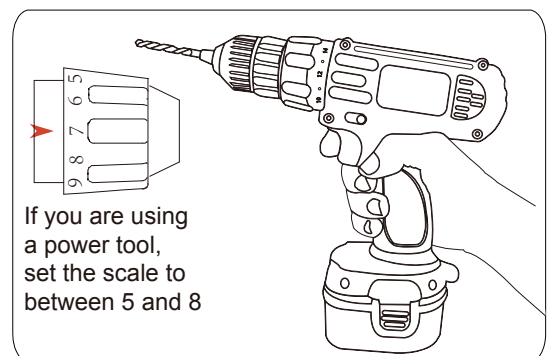
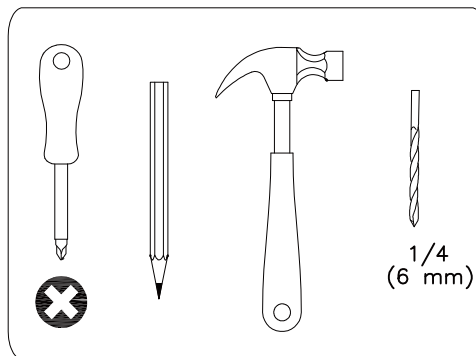

## **WARNING**



### **Furniture tipovers can be fatal to children. To minimize this risk:**







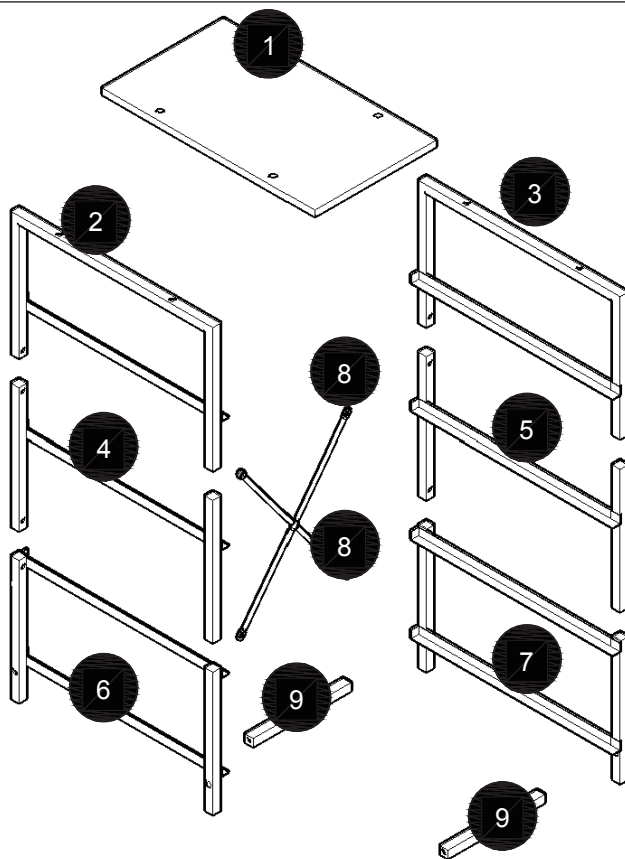

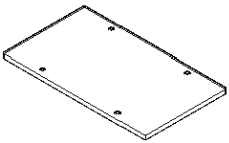
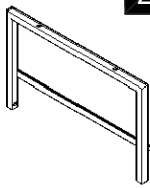
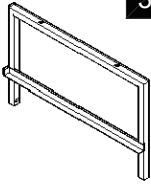
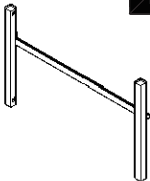
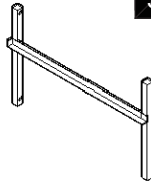
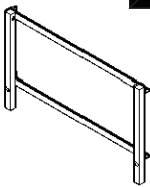
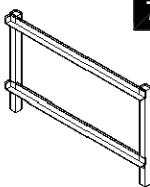
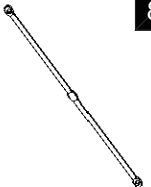

- **ALWAYS** use the tipover restraint provided.
- **DO NOT** place a TV or similar items on the product.
- **DO NOT** let children stand, climb or hang on drawers, doors, or shelves.
- **ONLY** open one drawer at a time.
- **STORE** the heaviest items in the bottom drawers.

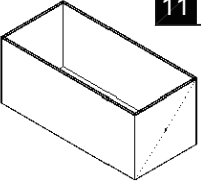
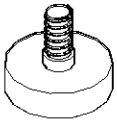
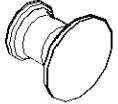

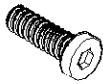
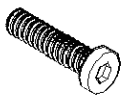
**This label must remain in place and cannot be removed.**

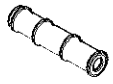
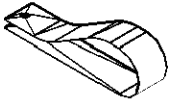

HARDWARE

 <b>1</b> x1	 <b>2</b> x1	 <b>3</b> x1	 <b>4</b> x1	 <b>5</b> x1
 <b>6</b> x1	 <b>7</b> x1	 <b>8</b> x2	 <b>9</b> x2	 <b>10</b> x8
 <b>11</b> x4	 <b>A</b> x4	 <b>B</b> x4	 <b>C</b> x12 6*10mm	 <b>D</b> x8 6*23mm
 <b>E</b> x4 6*30mm	 <b>F</b> x2 4*40mm	 <b>G</b> x2 6*30mm	 <b>H</b> x2	 <b>I</b> x4 4*8mm
 <b>J</b> x1	 <b>K</b> x4	 <b>N</b> x1		

C x6



D x2

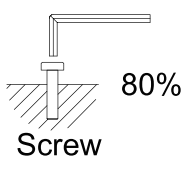
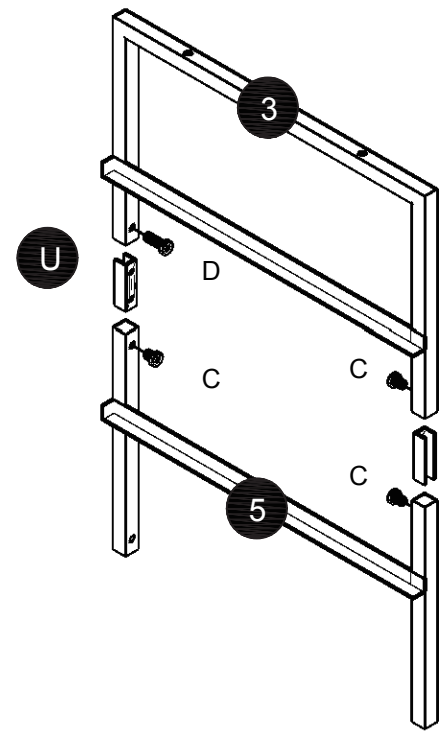
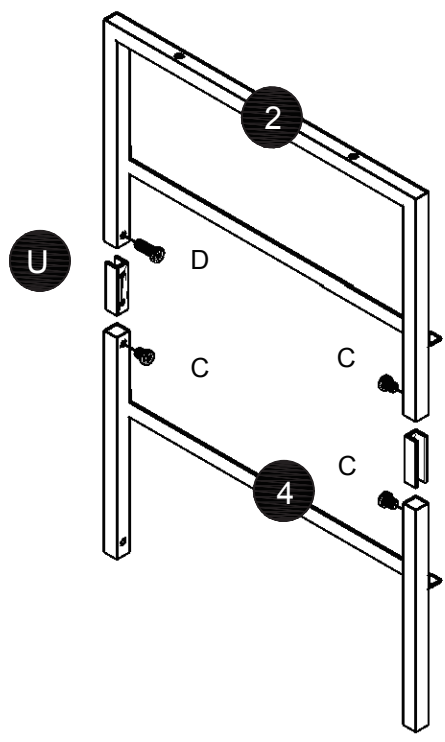

C x6



D x2

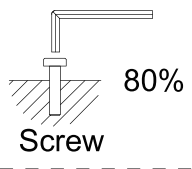
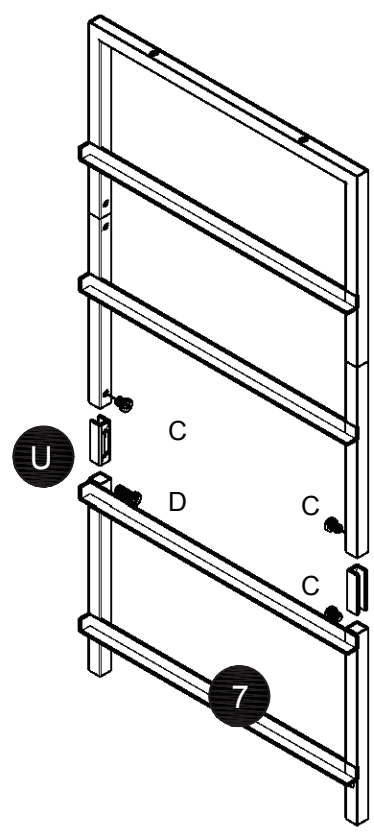
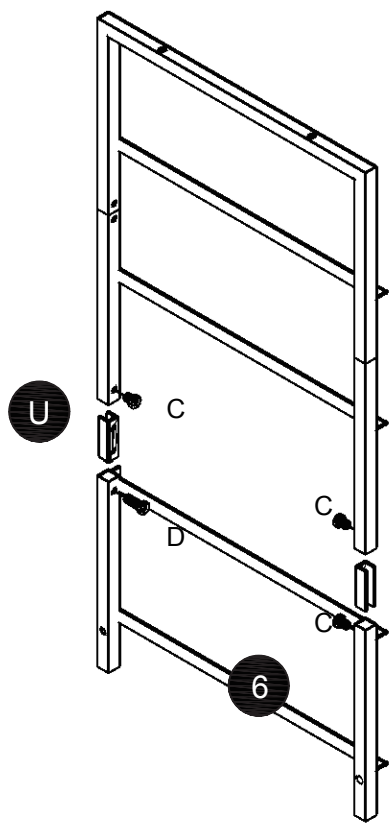

E x4

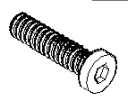

3

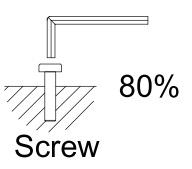
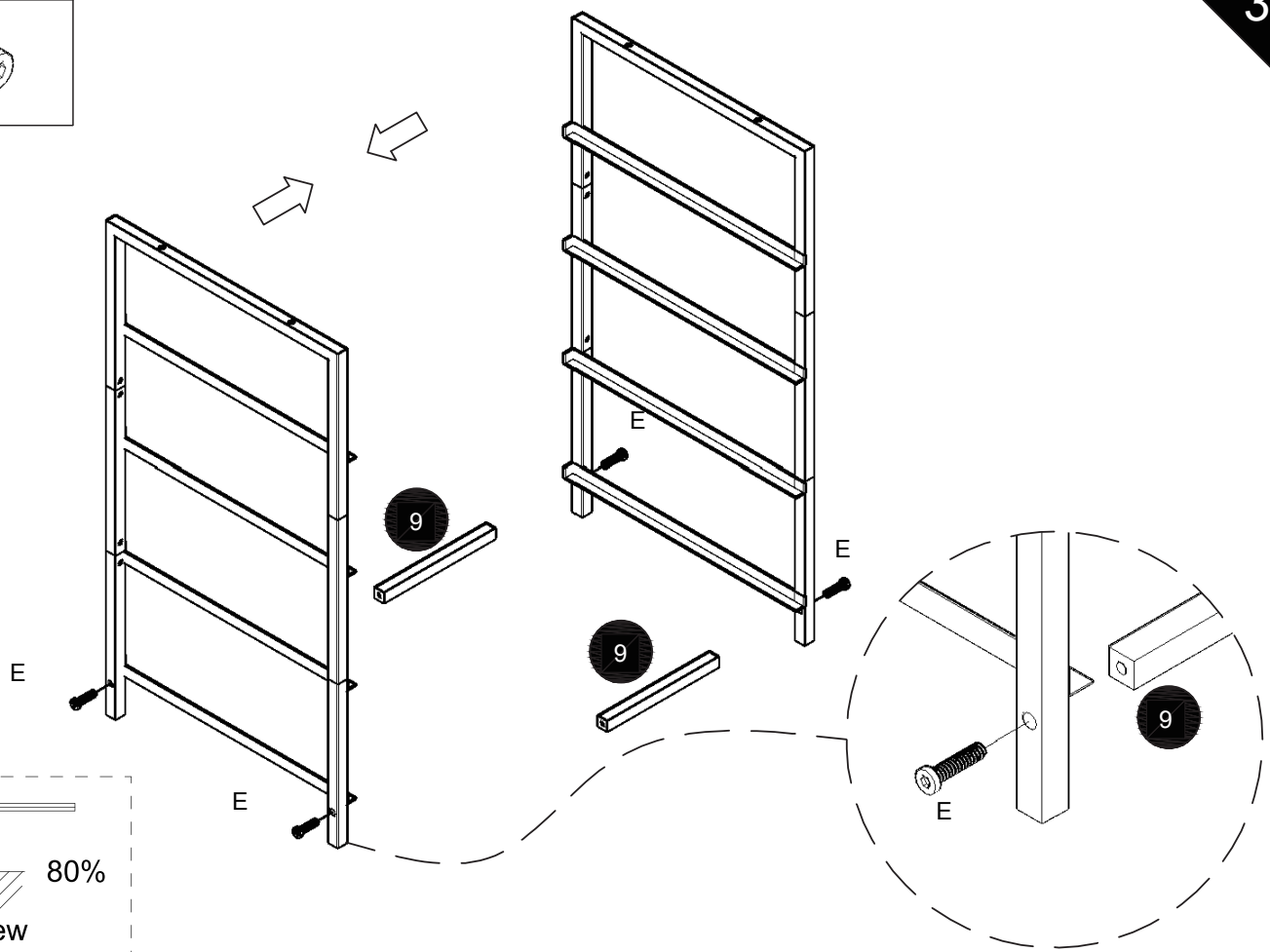

K x4



4

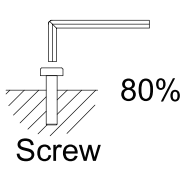
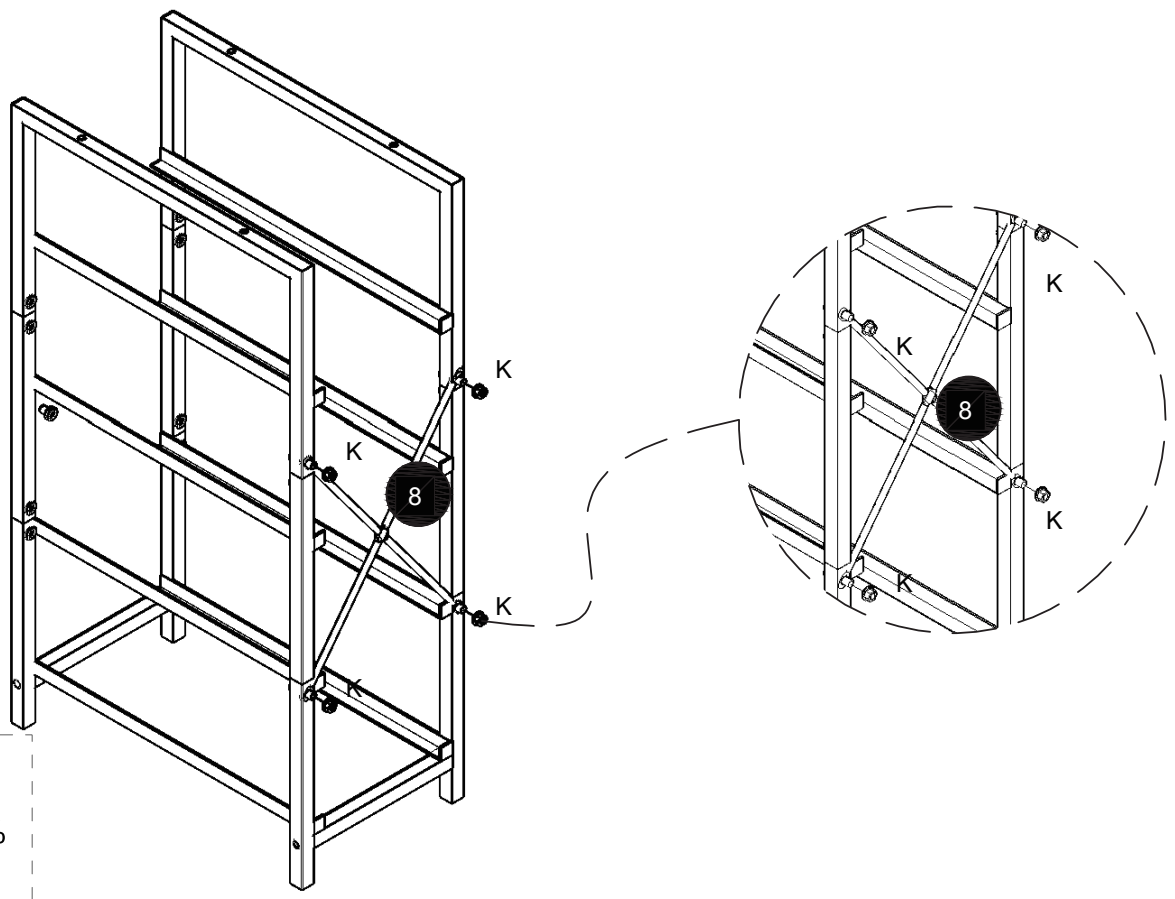

A x4



D x4

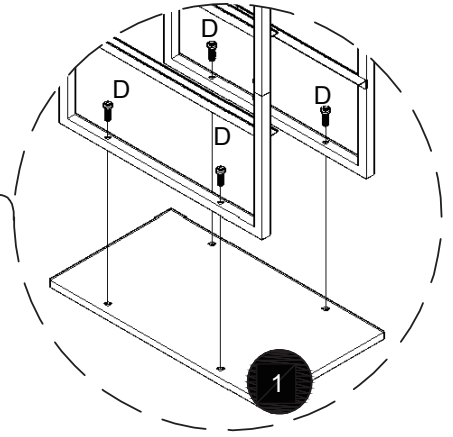
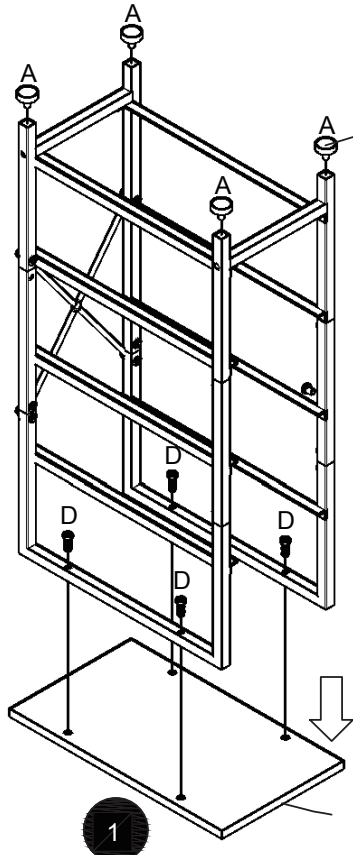
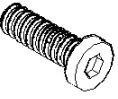

1

1

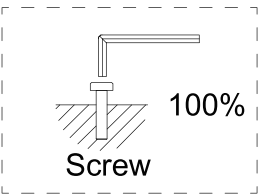

I x4



B x4

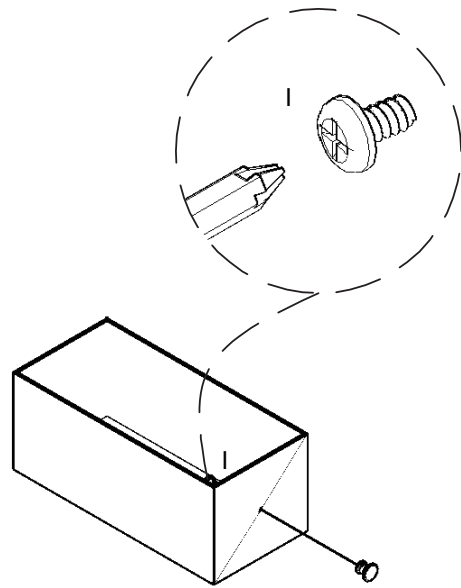
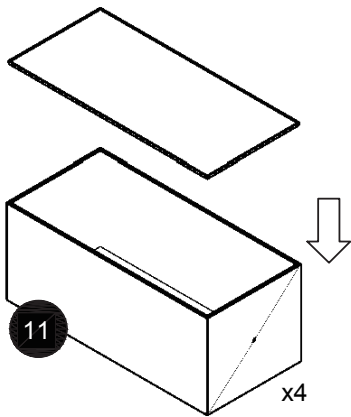

11

x4

B

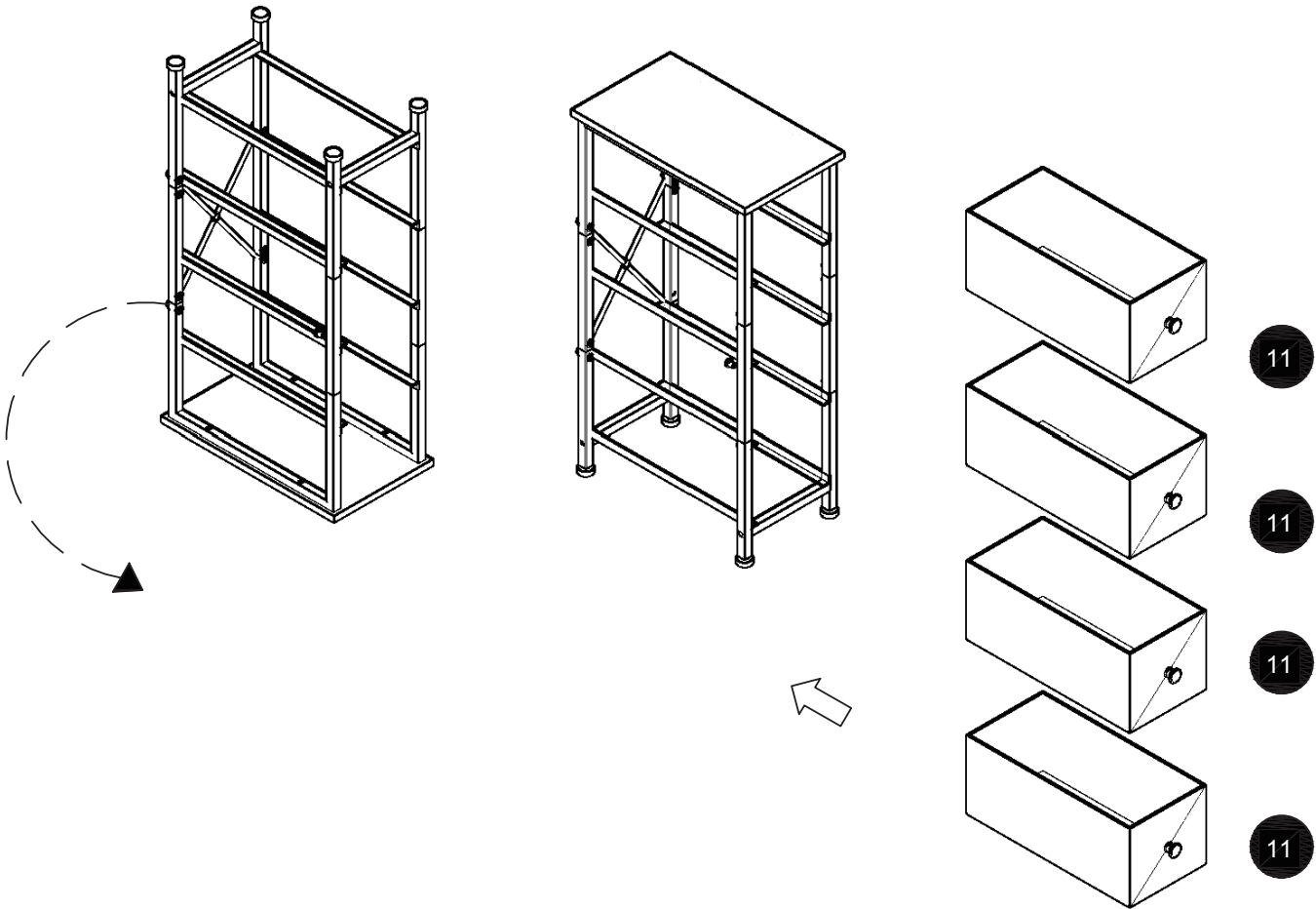

**G** x2

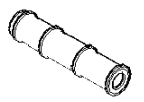

Please install anti-tip device as following steps if you need

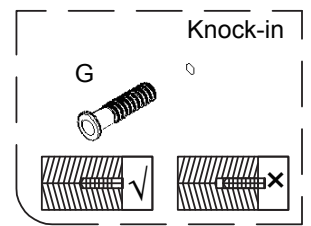
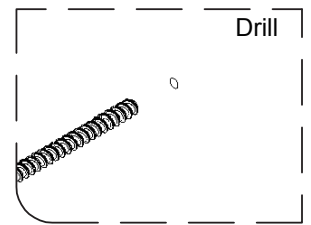
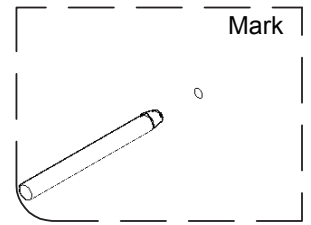
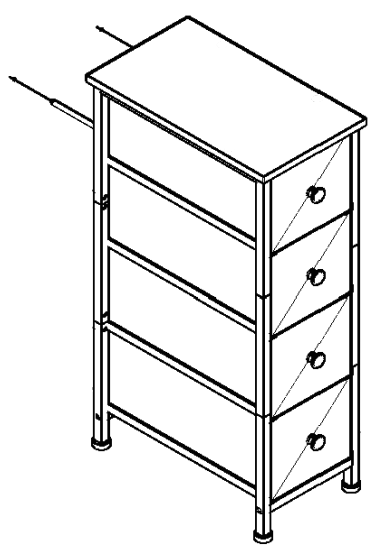

- Note:**
1. Mark on the wall
  2. Use an electric drill to drill deep holes in the wall
  3. Tap part G into the hole

F x2

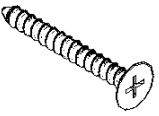

H x2

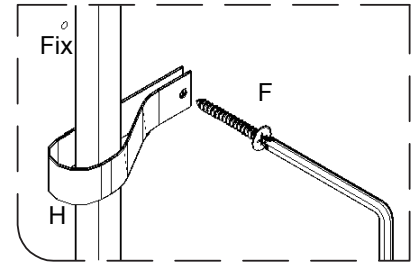
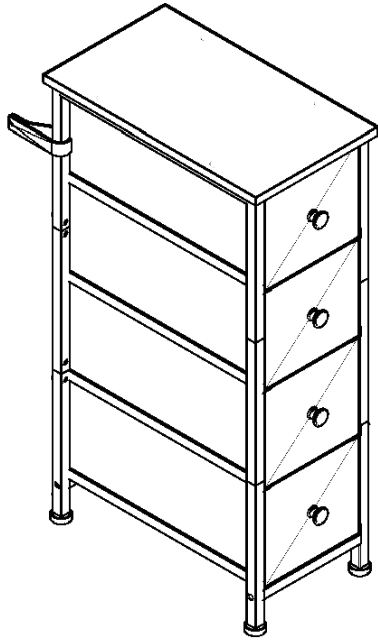

**Note:** Anti-tipping accessories can be installed on both sides.

