



ASSEMBLY INSTRUCTIONS

REVISION : A

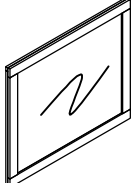

(BOX 1) Box Of Dresser

Item	Parts & Hardware	Description	Qty
A		Dresser	1 Pc

(BOX 2) Box Of Mirror

Item	Parts & Hardware	Description	Qty
B		Mirror	1 Pc
C		Mirror Support	2 Pcs

(BOX 2) Box Of Mirror (Hardware List)

Item	Parts & Hardware	Description	Qty
1	JCBC Screw M6 x35mm Spring Washer Ø 1/4" Flat Washer Ø 1/4" x 20mm		8 Pcs
2	L Key M4		1 Pc

REMARK : THE ANTI TIPPING HARDWARE IS LOCATED IN THE RIGHT SIDE FRONT DRAWER OF DRESSER

STEP 1

Attach Mirror Support (C) to the Mirror back (B), using JCBC Screw M6 x 35mm, Spring Washer Ø 1/4", Flat Washer Ø 1/4" x 20mm (1). Tighten using L Key M4 (2).

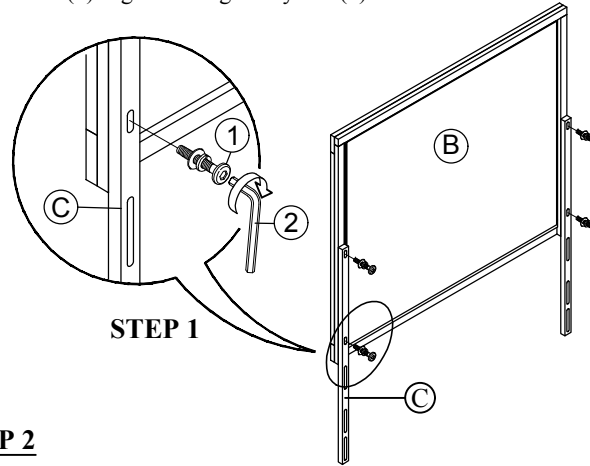

STEP 2

Place the mirror with support on the top of Dresser (A). Then *align center* as shown and tighten with JCBC screw M6 x 35mm, Spring Washer Ø 1/4", Flat Washer Ø 1/4" x 20mm (1). Tighten using L Key M4 (2).

