

# ASSEMBLY INSTRUCTIONS

---

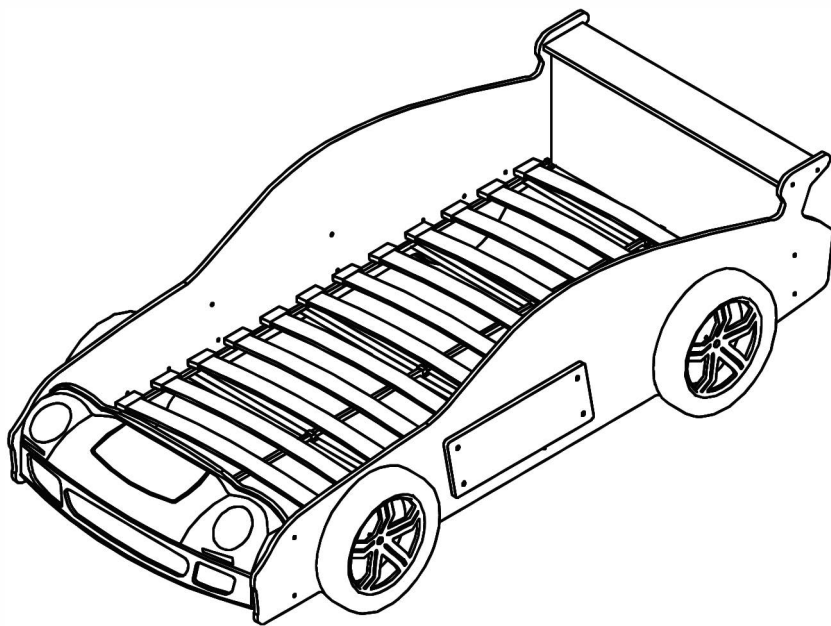

## TOOLS REQUIRED



**Allen Wrench**  
(Included)



**Phillips Screwdriver**  
(Not Included)



**2 - Persons Recommended**

## ASSEMBLY RATING



EASY —————> DIFFICULT

The Assembly Rating is a 5-point system showing the level of effort needed to assemble a specific product.



## **CHECK BEFORE STARTING**



### **Are you missing anything?**

Double-check all parts, hardware and accessories listed on Page 6 are accounted for.



### **Check out our Quick Tips!**

We recommend reviewing the pre-assembly handouts. Even experts need a refresher now and then!



### **Should we send any replacements?**

Are there any irregularities or flaws in the parts? We can send replacements!



### **Prep Time!**

Please review the assembly instructions and all diagrams prior to assembling. Arrange parts as recommended on Page 7 and group identical hardware together to make assembling easier.

# PRE ASSEMBLY INTRODUCTION

We understand building ready-to-assemble furniture can be a challenging experience for some. To help avoid confusion, we have provided some helpful tips that may speed up the process.

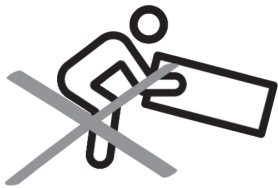

## Teamwork

ALWAYS have at least two people to help with transporting and assembling the product to avoid potential injury and/or damage.

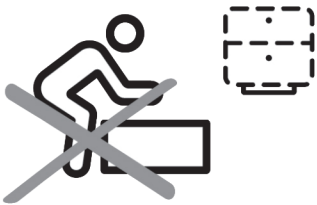

## Suitable Location

Assembling near the area of the intended location is highly recommended.



## Sufficient Space

Make sure you have enough space to move around during the assembly.



## Avoid Scratches

Use cardboard, blankets or a carpeted area while assembling furniture to prevent scratches.



## Flat Surface

Make sure the furniture rests on a flat and level surface with each leg evenly touching the floor.

# ASSEMBLY AND CARE ADVICE



**FAILURE TO FOLLOW THE GUIDELINES BELOW MAY RESULT IN INJURY AND/OR PROPERTY DAMAGE.**



Position each part correctly and insert screws or bolts into their respective holes.

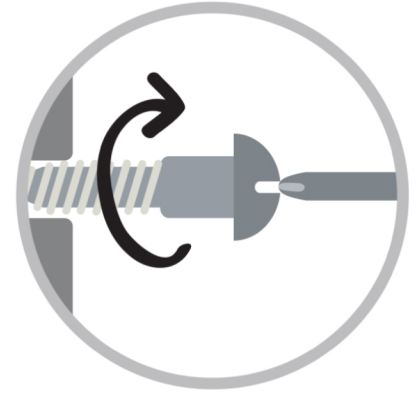

Turn clockwise to tighten and only tighten when step is completed or when instructed to do so.



Use the appropriate hand tools or power tools for assembly. Select steps, such as tightening screws and/or bolts, may require hand tools to avoid causing damage during assembly.



Save the instructions and store any supplied tools for later maintenance.



After two weeks, check and tighten any loose hardware and repeat again every six months thereafter.

**IT IS THE USER'S RESPONSIBILITY TO MAINTAIN THE FURNITURE. THE HARDWARE MAY LOOSEN OVER TIME AND MAY CAUSE THE FURNITURE TO BE WOBBLY AND UNABLE TO SUPPORT ITS INTENDED WEIGHT CAPACITY. THIS MAY LEAD TO COLLAPSE AND MAY CAUSE SERIOUS INJURY.**



- Please keep instructions for future reference.
- Check the quantity and irregularity of parts and hardware before you start.

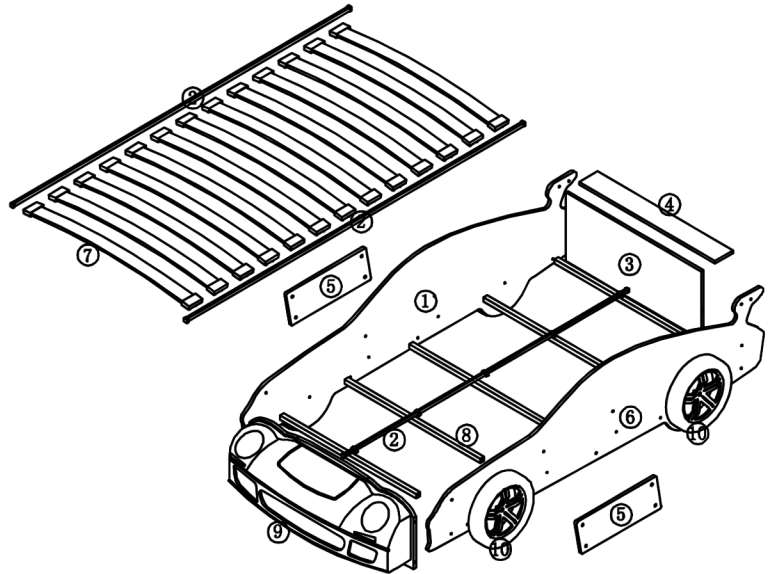

## PARTS

DESCRIPTION OF COMPONENT						
ITEM	WORK PIECE	MEASUREMENT	QTY	COLOUR	SHAPE	PACK IN
(1)	SIDE PANEL (L)	2235*632*15	1	WHITE		1/3
(2)	U SHAPED IRON	1910*15*15	3	SILVER		1/3
(3)	BACK BOARD	1000*390*15	1	WHITE		1/3
(4)	MIDDLE SUPPORT	1000*152*15	1	WHITE		1/3
(5)	MIDDLE DECORATE PIECE	564*200*15	2	WHITE		1/3
(6)	SIDE PANEL (R)	2235*632*15	1	WHITE		1/3
(7)	PLYWOOD SLAT	995*62*12	13	WHITE		2/3
(8)	SUPPORT POLE	1000*25*25	5	WHITE		2/3
(9)	FRONT BOARD	1000*329*300	1	WHITE		2/3
(10)	TYRE	350*350*35	4	BLACK		3/3
(11)	HARDWARE	216*114*57	1	-		3/3

## HARDWARE

A	B	C	D	E	F	G	H	I	J	K	J
M6*55 QTY:4	QTY:4	M6*50 QTY:22	QTY:5	QTY:30	QTY:26	QTY:12	QTY:2	QTY:2	QTY:8	M6*30 QTY:8	QTY:8

SCALE 1:1

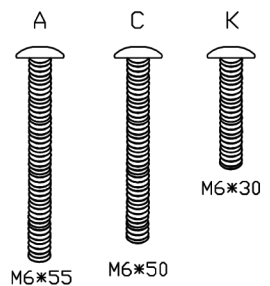

# ASSEMBLY INSTRUCTIONS

1

H



QTY:2

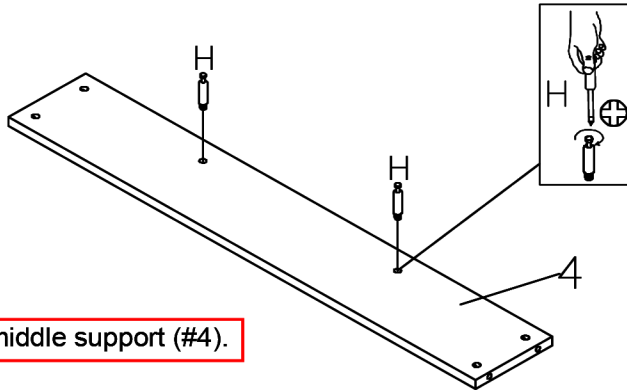

Secure cam bolts (#H) to middle support (#4).

Tip: Place parts on the flat level surface to ease alignment and assemble.

2

I



QTY:2

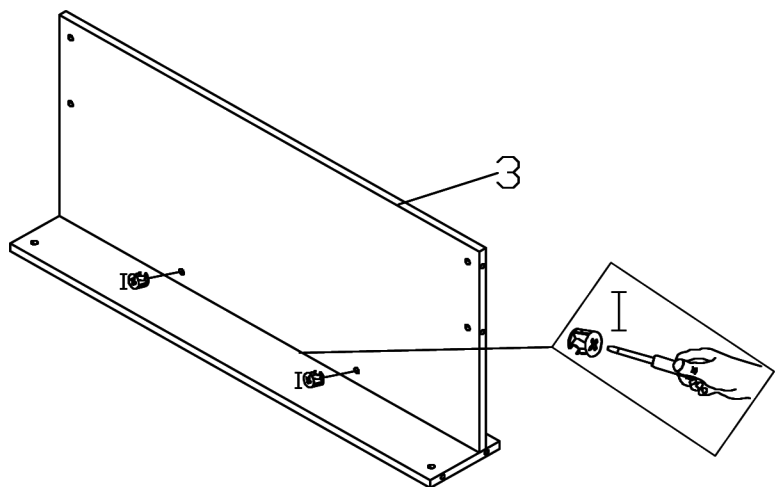

Align back board (#3) to the cam bolts of the middle support, then secure by using cam locks (#I).

# ASSEMBLY INSTRUCTIONS

## 3

C  M6\*50  
QTY:8

G   QTY:8

E  QTY:8

Align side panels (#1,6) to back panel, then secure by using bolts (#C) with washers (#E) to barrel nuts (#G). Cover barrel nuts (#G) by using barrel nut caps (#G).

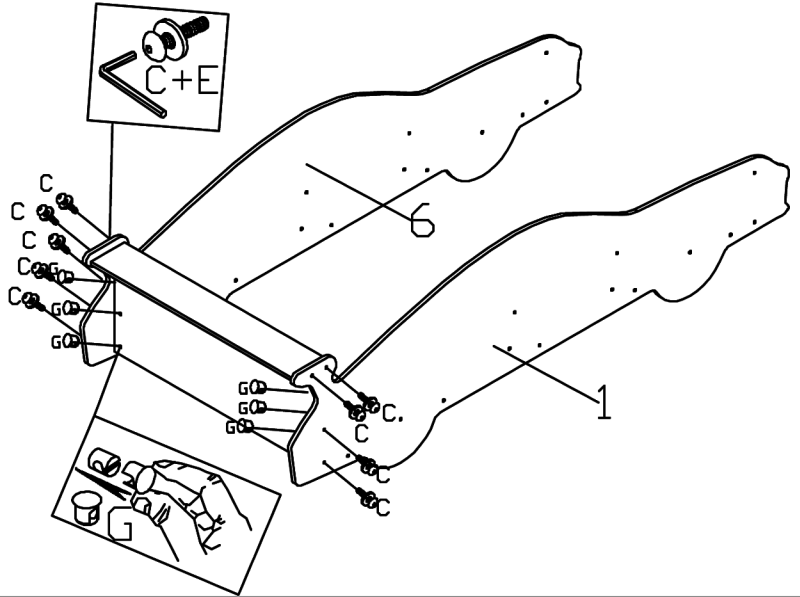

## 4

C  M6\*50  
QTY:10

E  QTY:10

Align support poles (#8) to the product, then secure by using bolts (#C) with washers (#E).

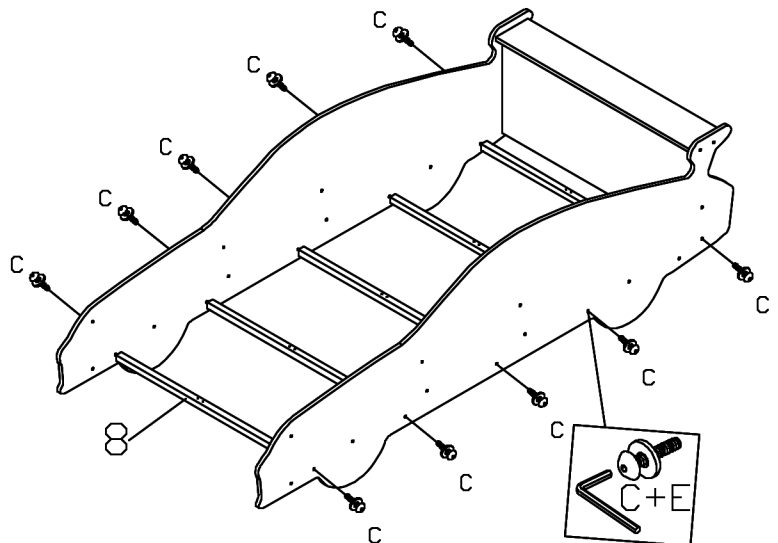

# ASSEMBLY INSTRUCTIONS

## 5

Align U-shaped iron (#2) to middle of product, then secure by attaching support brackets (#D).

D  QTY:5

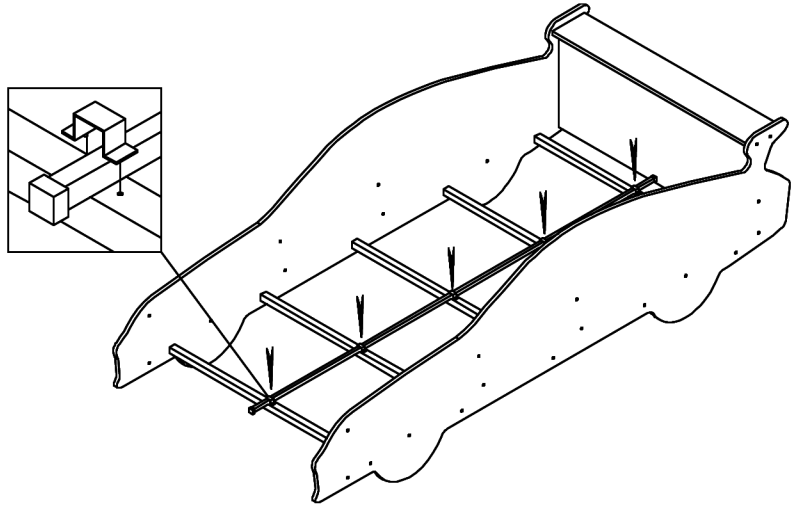

## 6

Align front panel (#9) to product, then secure by using bolts (#C) with washers (#E) to barrel nuts (#G). Cover barrel nuts (#G) by using barrel nut caps (#G).

C  M6\*50  
QTY:4

G  QTY:4

E  QTY:4

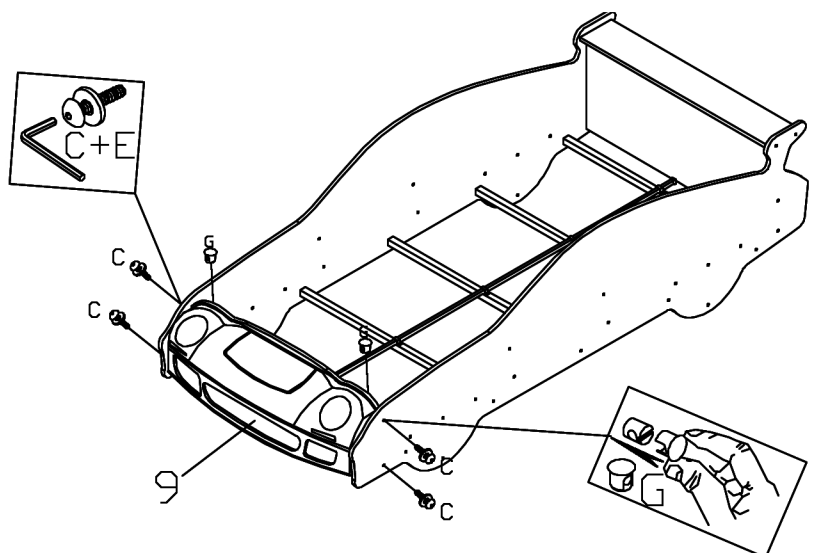

# ASSEMBLY INSTRUCTIONS

7

A  M6\*55  
QTY:4

B  QTY:4

Connect cords

Align tire caps (#B) to tire (#10), then secure by using bolts (#A).

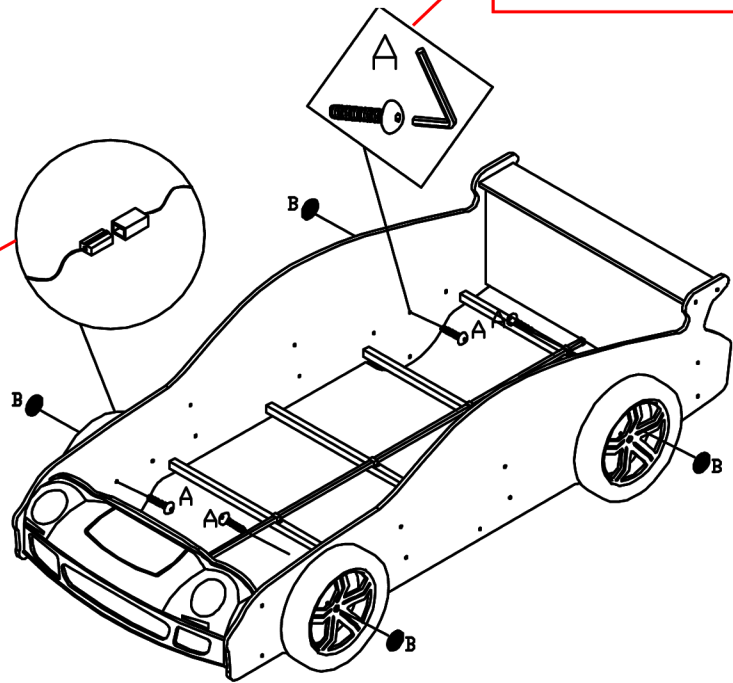

8

J  QTY:8

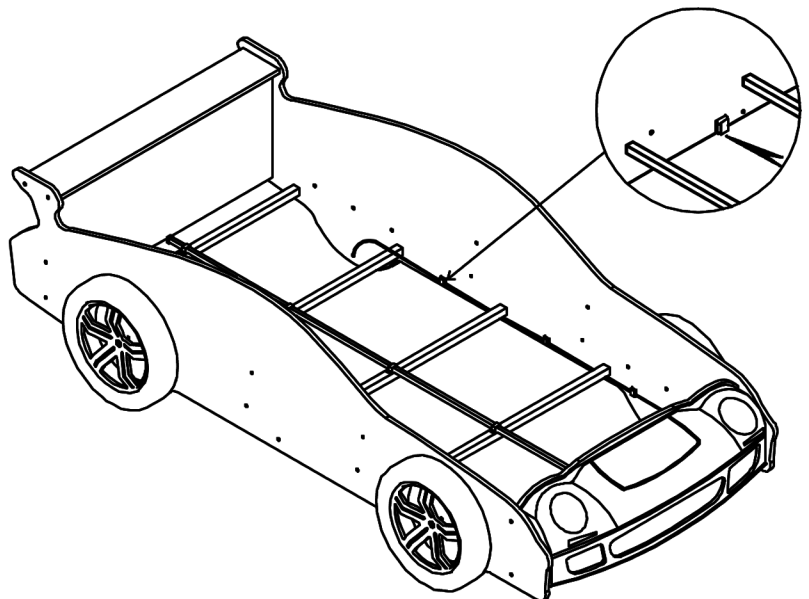

# ASSEMBLY INSTRUCTIONS

## 9

- K  M6\*30  
QTY:8
- E  QTY:8
- J  QTY:8

Align decorate pieces (#5) to product, then secure by using bolts (#K) with washers (#E) to nuts (#J).

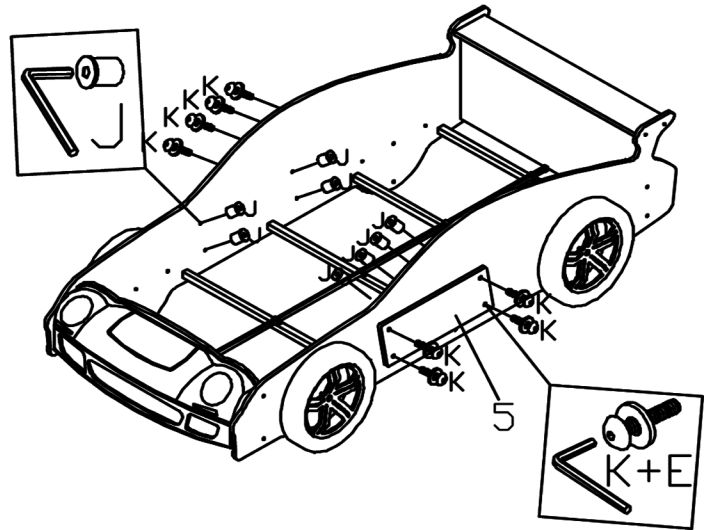

## 10

- F  QTY:26

Attach end caps (#F) to slats (#7).

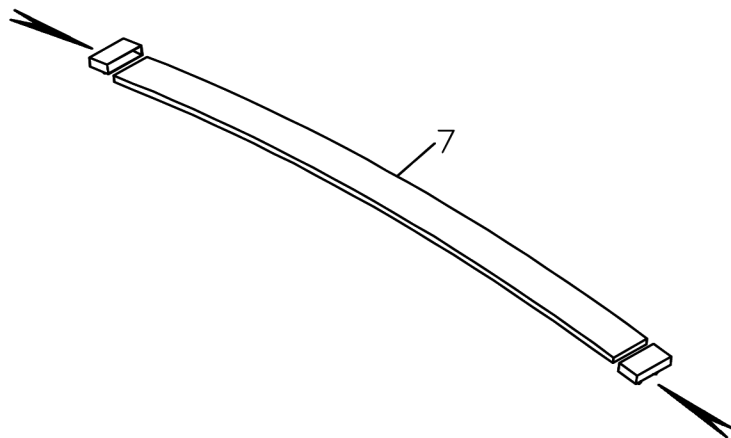

13X

# ASSEMBLY INSTRUCTIONS

11

Attach slats (#7) to U-shaped irons (#2).

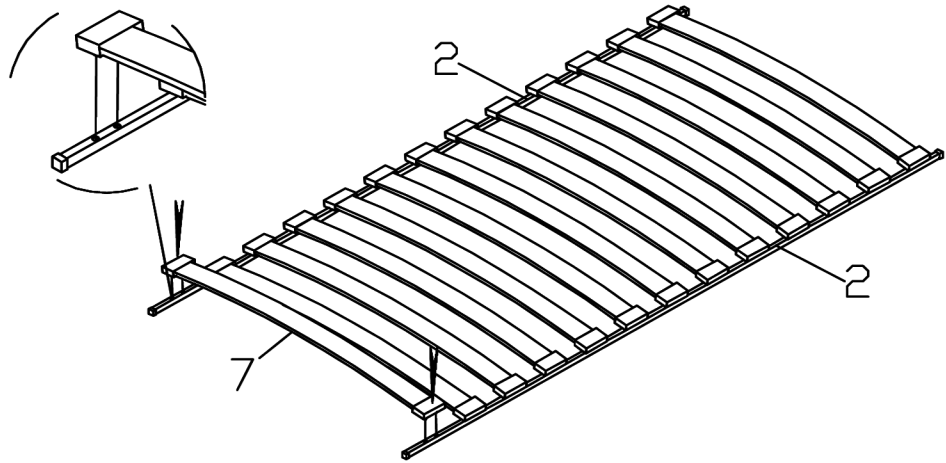

13X

12

Place slats to product.

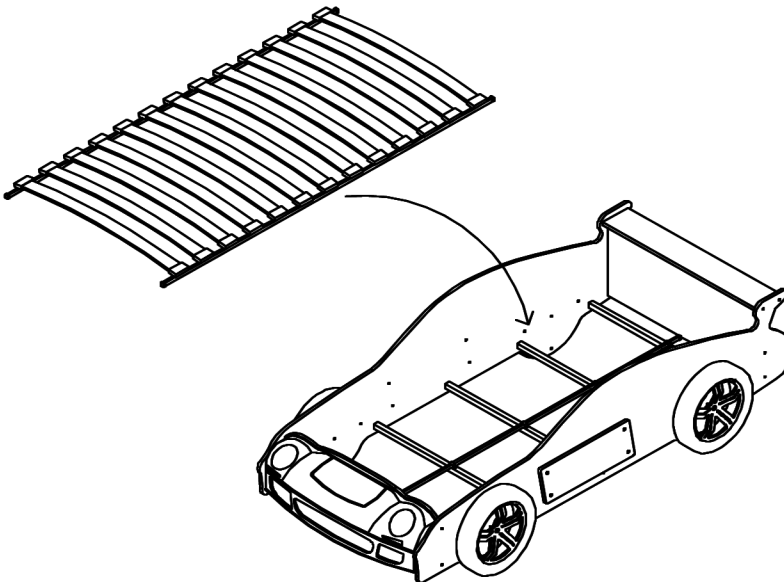

**ASSEMBLY  
COMPLETED**



Please ensure the furniture rests on an even and flat surface. If the product wobbles or feels loose, double-check all bolts and/or screws are properly tightened and secured.



**Keep this handy!**

Please retain this instruction manual and any order-related information for future reference.

# More Information

---

-User Age: 36 Months Or Above.

IMPORTANT, RETAIN FOR FUTURE REFERENCE: READ CAREFULLY

-Information regarding maintenance

Use dry, clean & soft cloth rub on the surface regularly; must not use any wet cloth, hardware or any hard material (such as keys, knife, sand-paper) rub on the surface. Keep away from water and any chemical substances.

-Conditions for use of the product domestic

-Installation only to be carried out by a competent person

-Article consists swallowable small parts, children  $\leq 3$  years should not be without parental guidance (surveillance or monitoring)

-Screw lock must be inserted before joining

-For the safety reason all of the hardware must be screwed tidely.

-This Product must be assembled by adult

-To avoid surface damage, tight all serew must not use over 5Nm power.

Use only mattress which is 74"-75" long, 37.5"-38.5" wide and 4"-6" height.