

TRIANGLE END TABLE

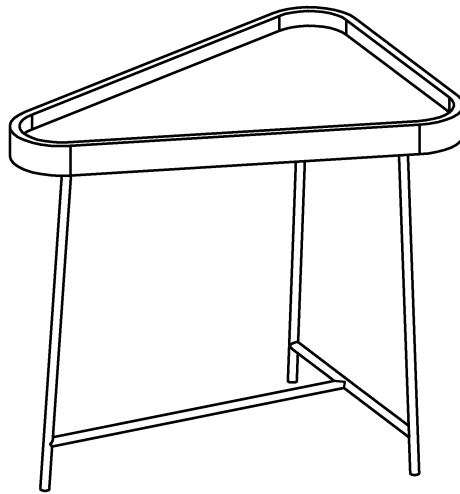





Assembly Instruction

We have designed our furniture with you, the customer in mind. Our clear, easy to follow step by step instructions will guide you through the project from start to finish. Feel confident that this will be a fun and rewarding project. The final product will be a quality piece of furniture that will go together smoothly and give years of enjoyment.

Please count and verify all parts are present before beginning assembly

Hardware List

| | | | |
|---|---|--|---|
| <p>A</p>  | <p>B</p>  | <p>C</p>  | <p>D</p>  |
| Short Bolt (6 pcs) | Long Bolt (1 pc) | Spring Washer (6 pcs) | Flat Washer (6 pcs) |
| <p>E</p>  | | | |
| Allen wrench (1 pc) | | | |

Parts List

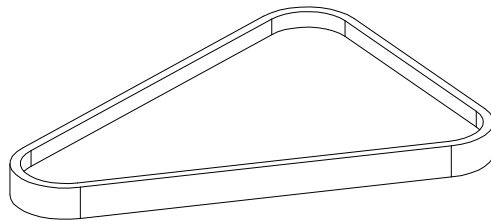

(1)- Top (1 pc)

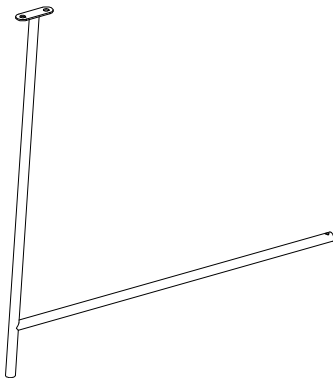

(2)- Leg With Stretcher (1 pc)

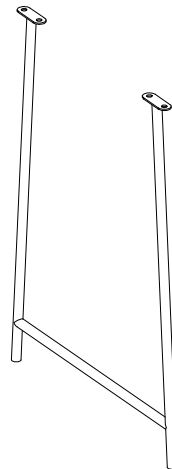

(3)- Double Leg With Stretcher (1 pc)

Assemble unit on carpet or other soft surface

Step 1

* Do Not Over tighten Sides

1. Connect Leg With Stretcher (2) to Double Leg With Stretcher (3) using Long Bolt (B) as shown.

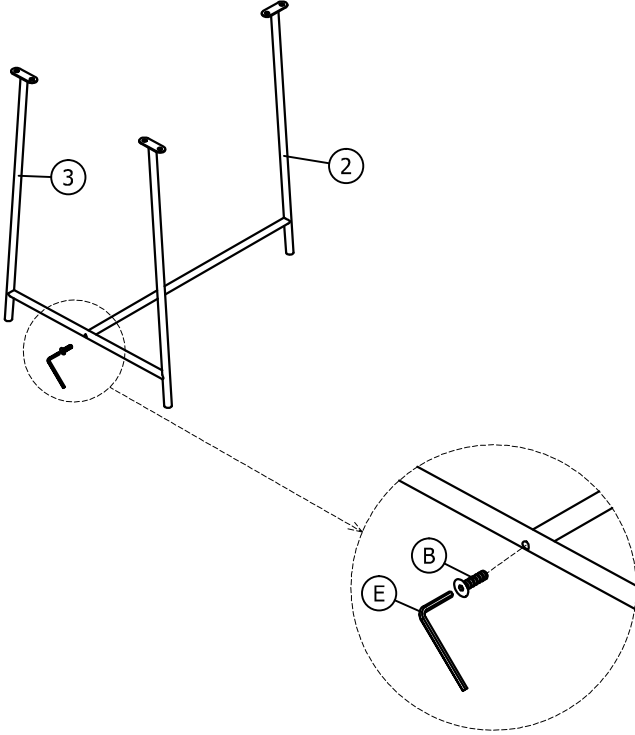

Step 2

1. Connect legs to Top (1) using Short Bolt (A), Spring Washer (C), Flat Washer (D) and Allen Wrench (E) as shown.

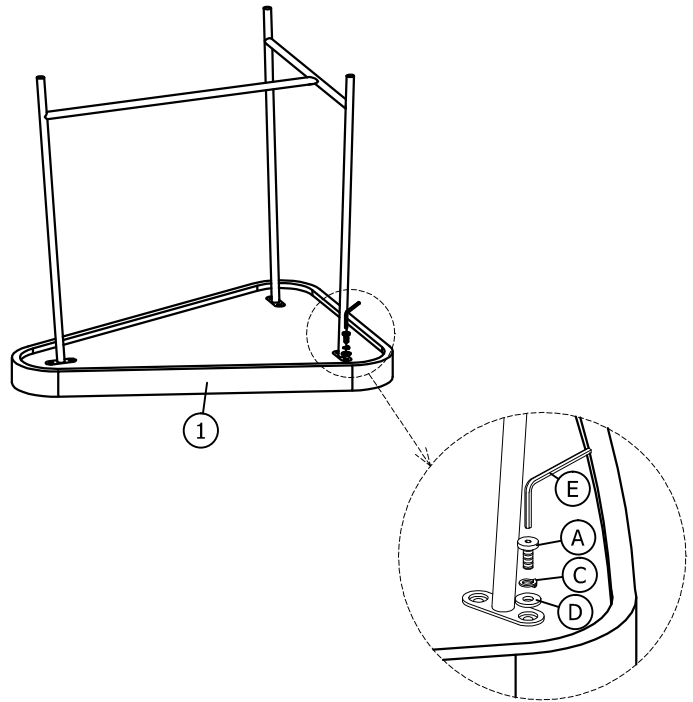

Step 3

1. Enjoy

