

ASSEMBLY INSTRUCTIONS

DINING CHAIR

A Chair Back

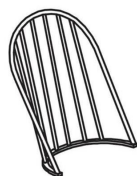

1 pc

B Left Leg



1 pc

C Right Leg



1 pc

D Seat



1 pc

E Center Cross Bar



1 pc

F Bolt with
Lock Washer
and Flat
Washer
1/4", 5/8"



10 pcs

G Pan Head Bolt
1/4", 1-3/4"



4 pcs

H Lock Washer
1/4"



4 pcs

I Flat Washer
1/2"



4 pcs

J Allen Wrench
2 3/4", 1/4"

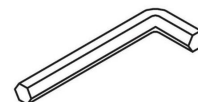

1 pc

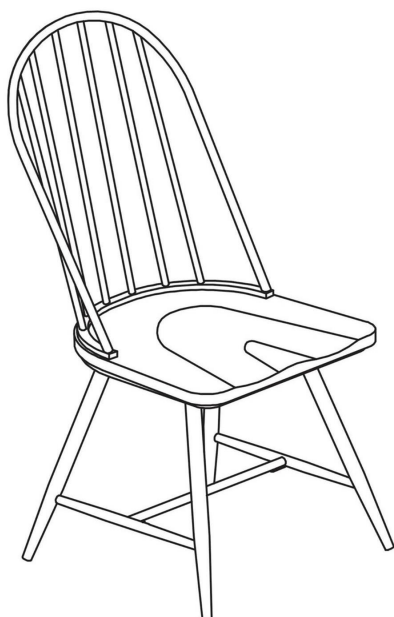

This page lists all the contents included in the box. Please take the time to identify the hardware as well as the individual components to this product. As you unpack and prepare for assembly, place the contents on a carpeted or padded area to protect them from damage.

1 Place Seat (D) upside down on a stable, smooth and carpeted surface. Then, attach Left & Right Leg (B & C) to Seat (D) using Bolt with Lock Washer and Flat Washer (F) with Allen Wrench (J).

Take the Allen Wrench and turn the bolts until the legs are secured. **DO NOT TIGHTEN COMPLETELY.** Stop when you feel you are adding force to tighten the bolts.

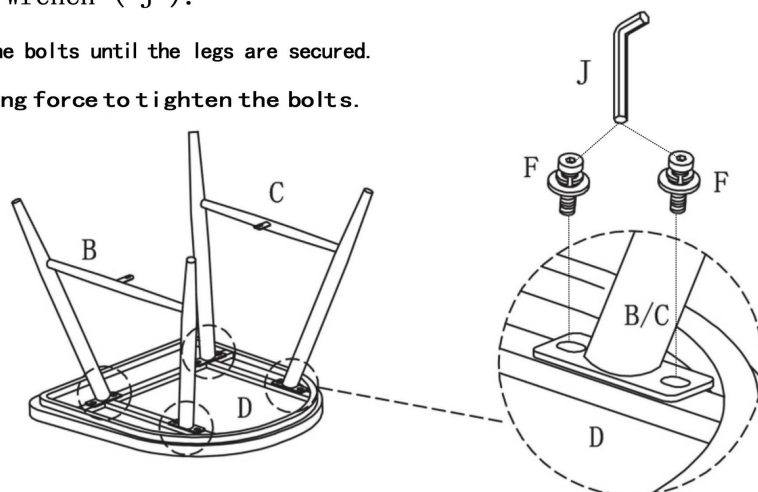

2 Align and attach Center Cross Bar (E) to Left & Right Leg (B & C) using Bolt with Lock Washer and Flat Washer (F) with Allen Wrench (J).

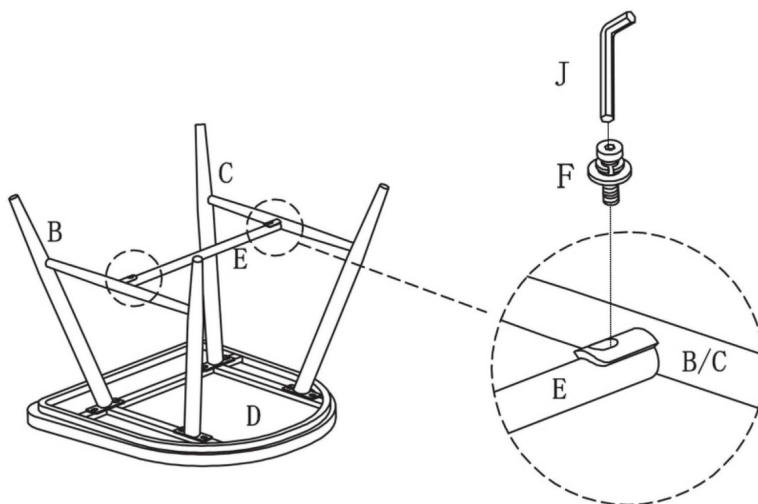

3 Stand the assembled seat with legs upright. Then, attach Chair Back (A) to Seat (D) using Pan Head Bolt (G), Lock Washer (H) and Flat Washer (I) with Allen Wrench (J).

Stand the chair on an even surface and check for balance. If it wobbles, press down on the uneven leg and tighten the bolts. Once balanced, apply even pressure to the center and tighten all bolts without over-tightening.

Helpful Tip: While tightening the bolts from underneath, have someone sit in the chair.

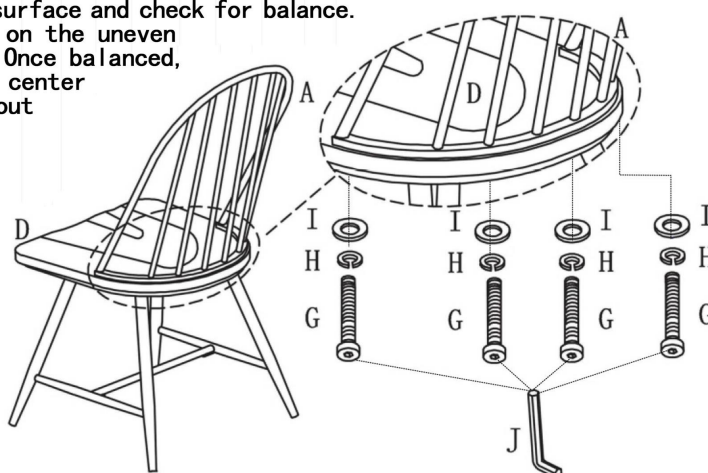

Cleaning & Care

Treat surfaces with care. Surfaces are resistant to scratches but are not scratch resistant. Clean surfaces with a dry or damp soft cloth. Do not use abrasive cleaners. Hardware may loosen over time. Periodically check that all connections are tight.