

ASSEMBLY INSTRUCTIONS

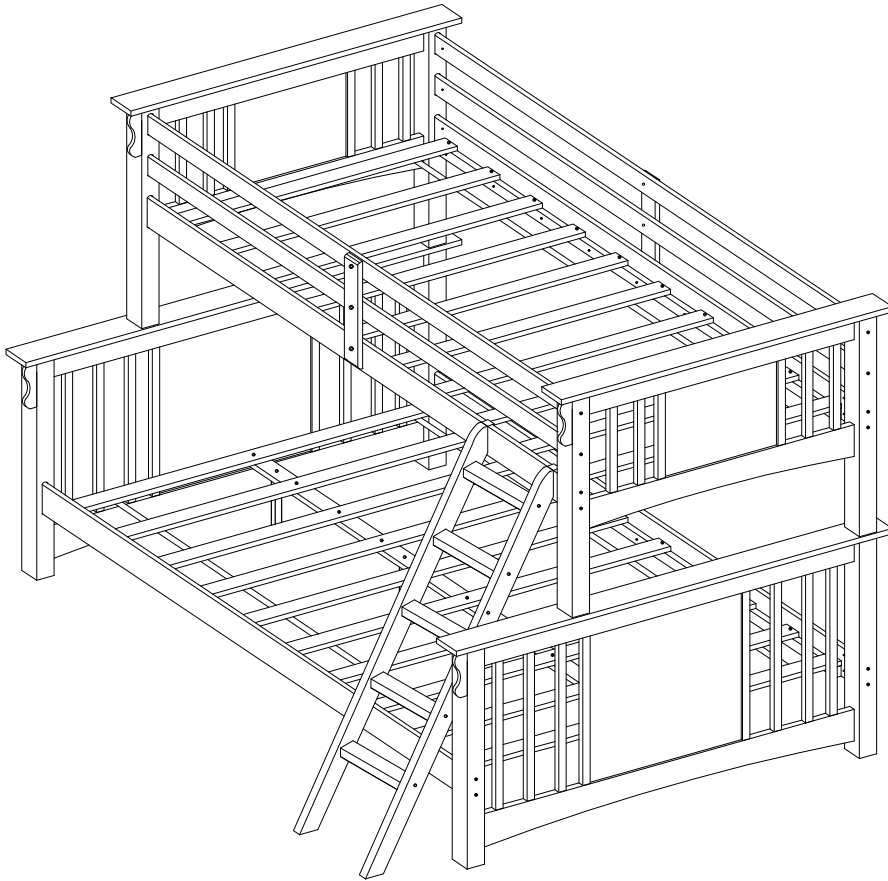

TOOLS REQUIRED



Allen Wrench

(Included)



Phillips
Screwdriver

(Not Included)



3 - People
Recommended

ASSEMBLY RATING



EASY —————> DIFFICULT

The Assembly Rating is a 5-point system showing the level of effort needed to assemble a specific product.

Thank you for your purchase!

We hope you enjoy this new addition to your home for many years to come.



CHECK BEFORE STARTING

Are you missing anything?

Double-check all parts, hardware and accessories listed on Page 6 are accounted for.

Check out our Quick Tips!

We recommend reviewing the pre-assembly handouts. Even experts need a refresher now and then!

Should we send any replacements?

Are there any irregularities or flaws in the parts? We can send replacements!

Prep Time!

Please review the assembly instructions and all diagrams prior to assembling. Arrange parts as recommended on Page 7 and group identical hardware together to make assembling easier.

PRE ASSEMBLY INTRODUCTION

We understand building ready-to-assemble furniture can be a challenging experience for some. To help avoid confusion, we have provided some helpful tips that may speed up the process.

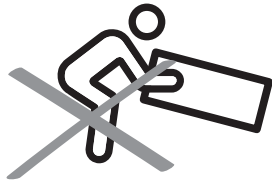

Teamwork

ALWAYS have at least two people to help with transporting and assembling the product to avoid potential injury and/or damage.

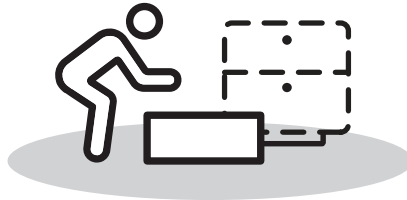
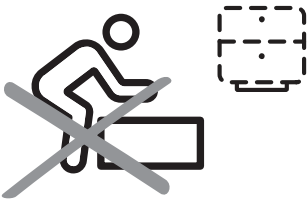

Suitable Location

Assembling near the area of the intended location is highly recommended.



Sufficient Space

Make sure you have enough space to move around during the assembly.



Avoid Scratches

Use cardboard, blankets or a carpeted area while assembling furniture to prevent scratches.

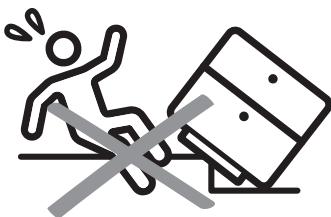

Flat Surface

Make sure the furniture rests on a flat and level surface with each leg evenly touching the floor.

ASSEMBLY AND CARE ADVICE



FAILURE TO FOLLOW THE GUIDELINES BELOW MAY RESULT IN INJURY AND/OR PROPERTY DAMAGE.



Position each part correctly and insert screws or bolts into their respective holes.

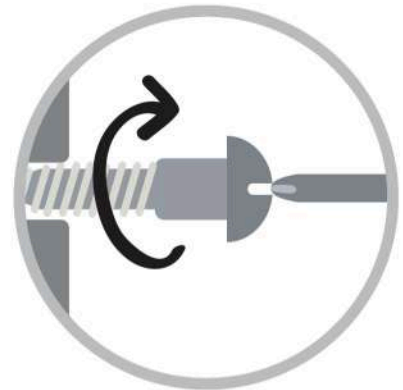

Turn clockwise to tighten and only tighten when step is completed or when instructed to do so.



Use the appropriate hand tools or power tools for assembly. Select steps, such as tightening screws and/or bolts, may require hand tools to avoid causing damage during assembly.



Save the instructions and store any supplied tools for later maintenance.

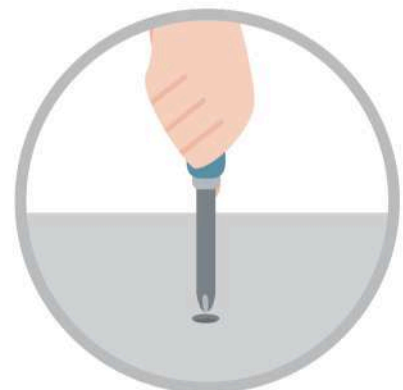

After two weeks, check and tighten any loose hardware and repeat again every six months thereafter.

IT IS THE USER'S RESPONSIBILITY TO MAINTAIN THE FURNITURE. THE HARDWARE MAY LOOSEN OVER TIME AND MAY CAUSE THE FURNITURE TO BE WOBBLY AND UNABLE TO SUPPORT ITS INTENDED WEIGHT CAPACITY. THIS MAY LEAD TO COLLAPSE AND MAY CAUSE SERIOUS INJURY.

BUNKBED



- Please keep instructions for future reference.
- Check the quantity and irregularity of parts and hardware before you start.

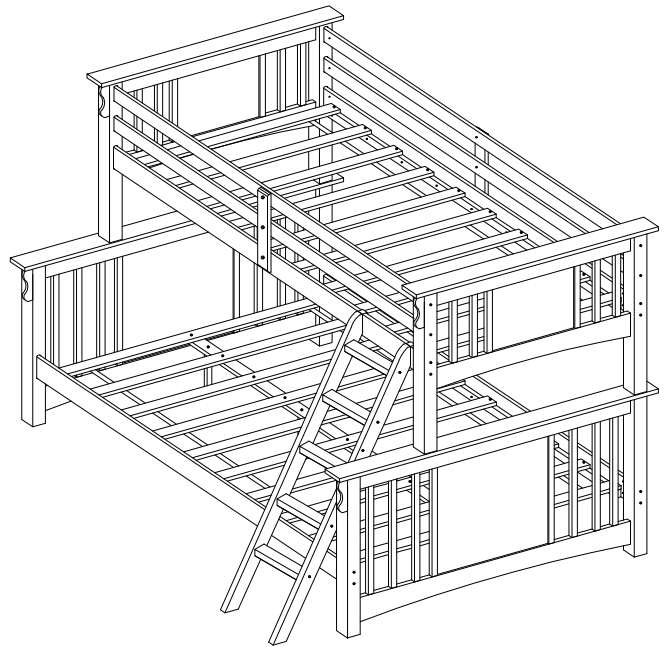

PARTS

#1 1pc

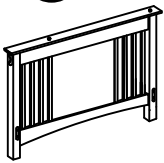

Lower End Guardrail (Lt)

#2 1pc

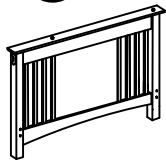

Lower End Guardrail (Rt)

#3 2pcs

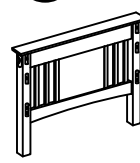

Upper End Guardrail (Lt,Rt)

#4 2pcs

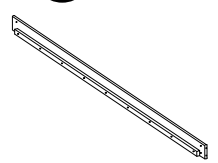

Lower Side Rail

#5 2pcs

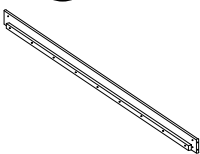

Upper Side Rail

#6 4pcs

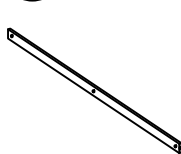

Guardrail

#7 1pc

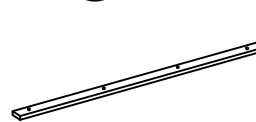

Support Slat Kit

#8 4pcs



Support Leg

#9 1Set

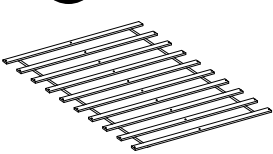

Full Slat Kit

#10 2 Set

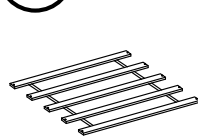

Twin Slat Kit

#11 2pcs

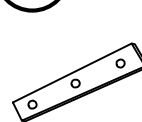

Guardrail Support

#12 5pcs

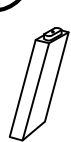

Ladder Steps

#13 1pc

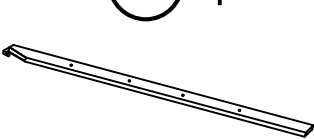

Ladder Rail (L)

#14 1pc



Ladder Rail (R)

HARDWARE

#A 24pcs



Bolt
Ø1/4" x 4-7/8"

#B 24pcs



Barrel Nut Ø1/4"x1/2"

#C 50pcs



Screw
#4x30mm

#D 6pcs



Bolt
Ø1/4" x 1-3/16"

#E 10pcs



Screw
Ø3/16" x 2"

#F 4pcs



Screw
#4x40mm

#G 4pcs

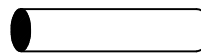

Metal Dowel
Ø9*90mm

#H 2pcs



Screw
#4x20mm

#I 1pc



Allen Wrench 4mm

#J 6pcs







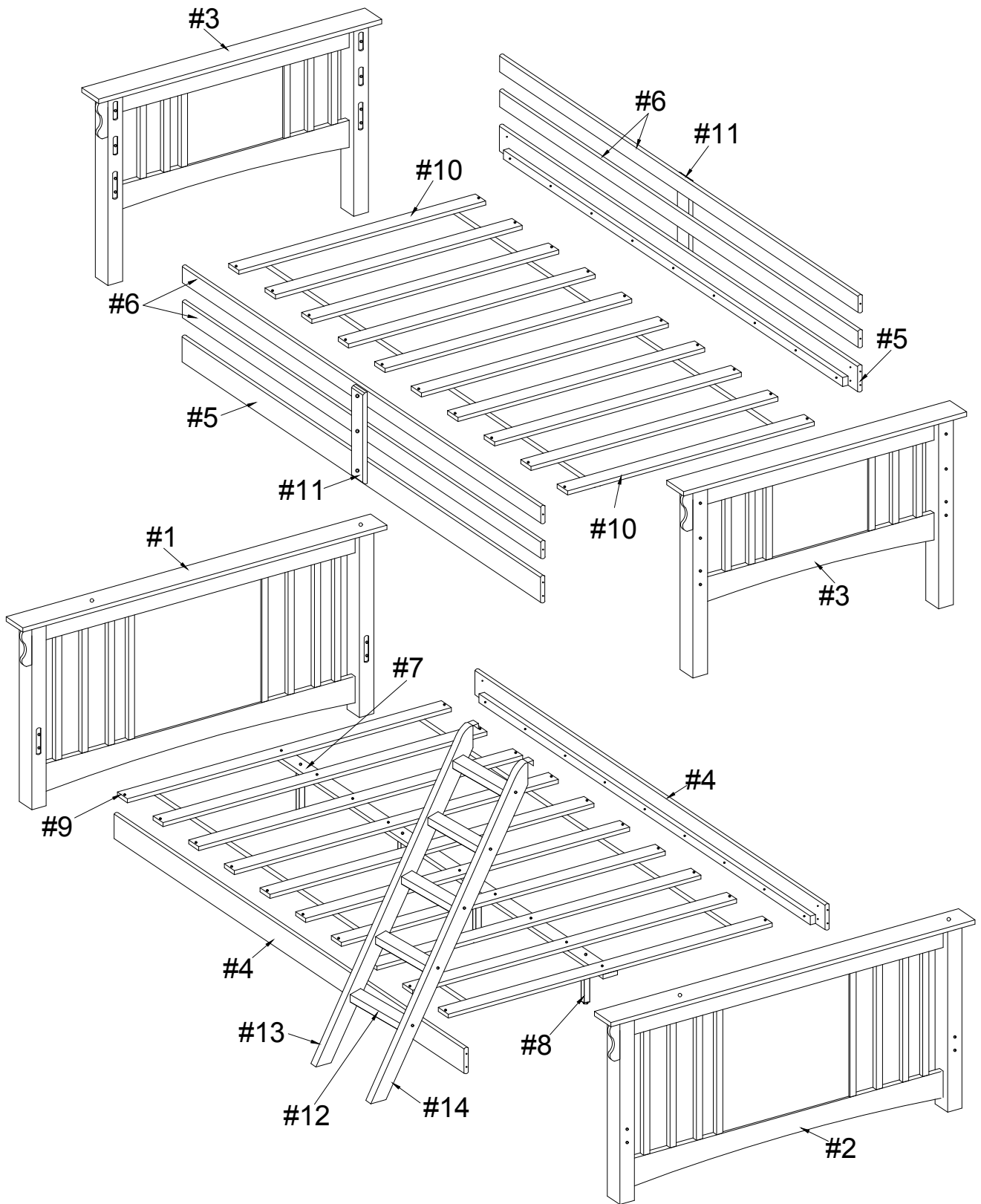



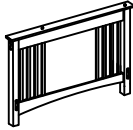
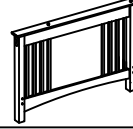
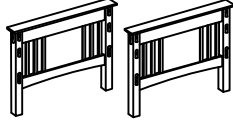
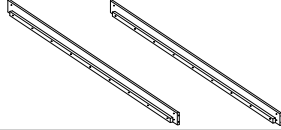

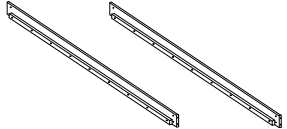

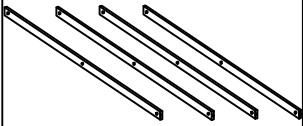

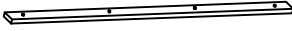

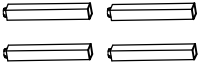
Hex Cap
Ø1/4" x 5/8"

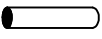
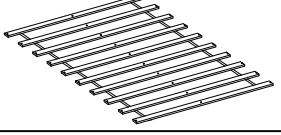
Exploded View

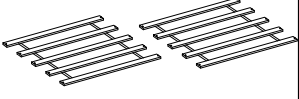

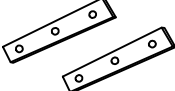
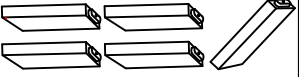
packed in 2 cases

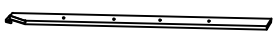
Carton	Disignation	Part	Hardware	
	Lower End Guardrail(Lt)	#1		
	Lower End Guardrail(Rt)	#2		
	Upper End Guardrail(Rt,Lt)	#3		
	Lower Side Rail	#4		 #Ax24pcs
	Upper Side Rail	#5		 #Bx24pcs  #Cx50pcs
	Guardrail	#6		 #Dx6pcs  #E x10pcs
	Support Slat Kit	#7		 #Fx4pcs
	Support Leg	#8		 #Gx4pcs  #Hx2pcs
	Full Slat Kit	#9		 #Ix1pc
	Twin Slat Kit	#10		 #Jx6pcs
	Guardrail Support	#11		
	Ladder Steps	#12		
	Ladder Rail (L)	#13		
	Ladder Rail (R)	#14		

ASSEMBLY INSTRUCTIONS

1

- Part #1 x 1pc
- Part #2 x 1pc
- Part #4 x 2pcs
- Hardware #A x 8pcs
- Hardware #B x 8pcs

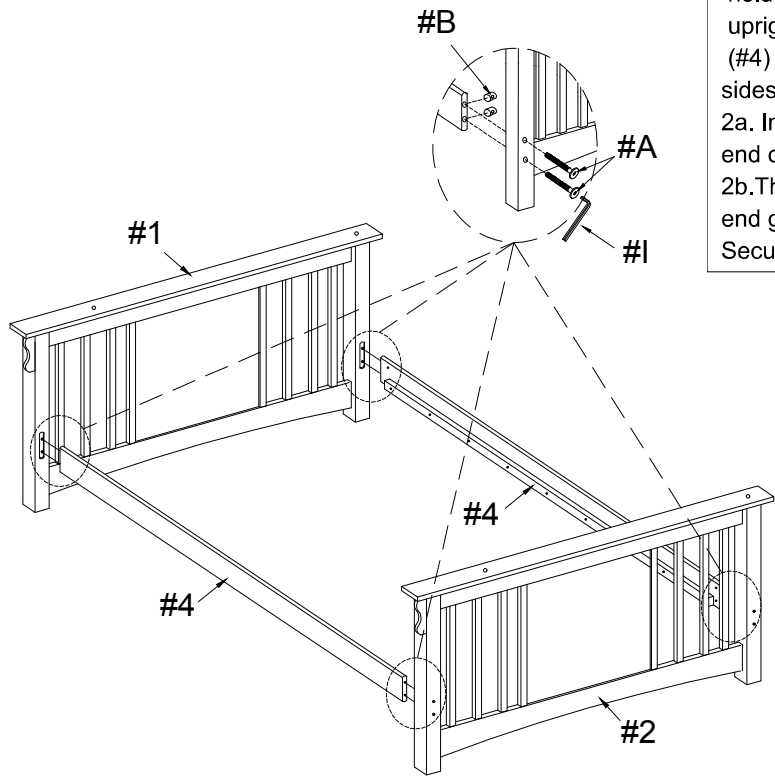

1. With the help of another person, hold the lower end guardrails (#1&2) upright and align the lower side rails (#4) to the pre-drilled holes along the sides of those guardrails.
2a. Insert 2 barrel nuts (#B) into each end of the lower side rails (#4).
2b. Then insert 2 bolts (#A) into the lower end guardrails (#1) to lock with the rails. Secure using the Allen wrench (#1).

2

- Part #7 x 1pc
- Part #8 x 4pcs
- Hardware #F x 4pcs

Align 4 support legs (#8) to the pre-drilled hole along the support slat kit (#7). Insert a screw (#F) into each hole from above and secure using a Phillips screwdriver.

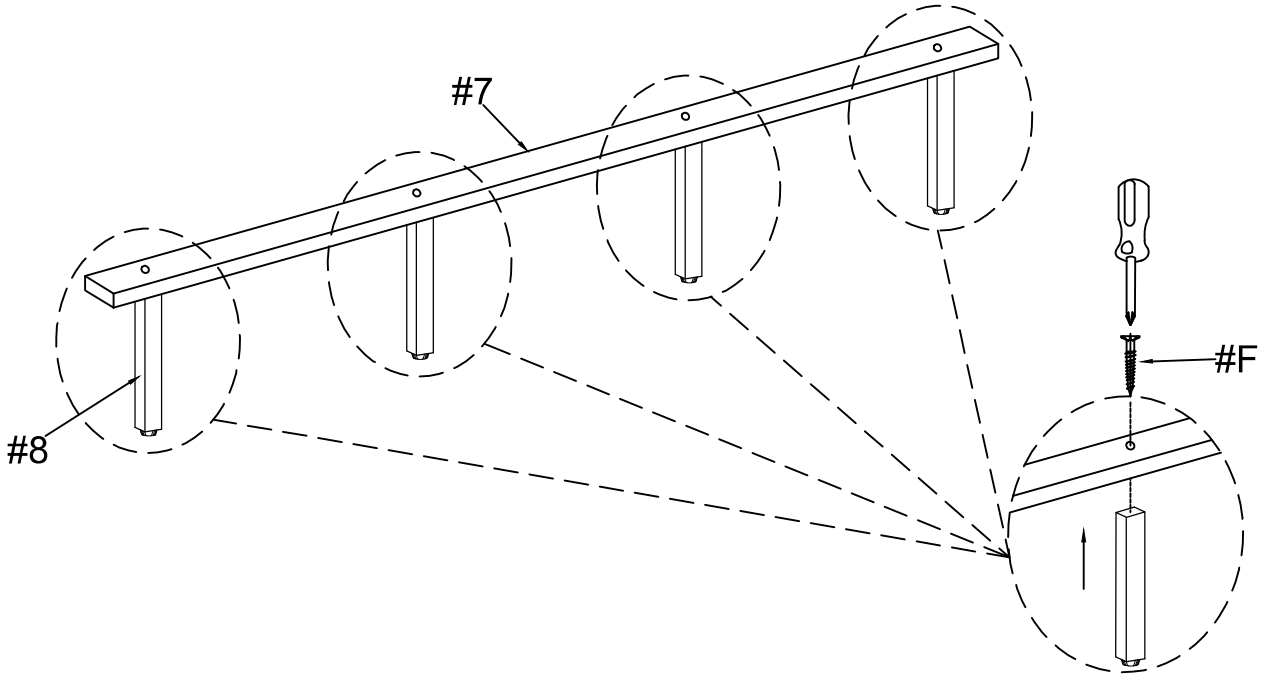

ASSEMBLY INSTRUCTIONS

3

Part **#9** x 1 Set
Hardware **#C** x 30pcs

1. Align the top of the center support (**#7**) to the full slat kit (**#9**).
Insert a screw (**#C**) into each hole from above and secure using a Phillips screwdriver

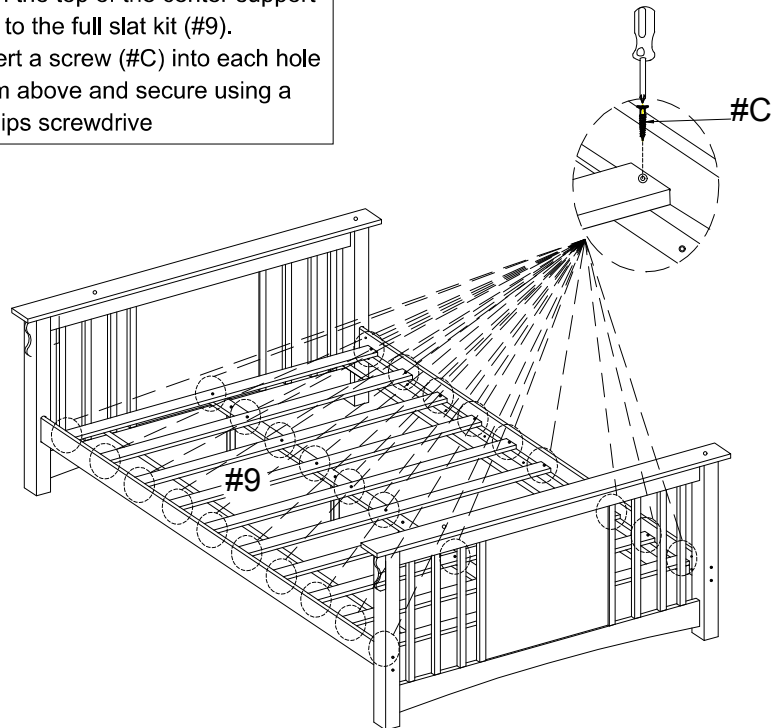

2. Place the full slat kit (**#9**) onto the lower side rails (**#4**). Align the ends of the slats to the pre-drilled holes located on the inner side of the lower side rails (**#4**). Insert a screw (**#C**) into each end and secure using a Phillips screwdriver.

4

Part **#3** x 2pcs
Part **#5** x 2pcs
Part **#6** x 4pcs
Hardware **#A** x 16pcs
Hardware **#B** x 16pcs

1. With the help of another person, hold the upper end guardrails (**#3**) upright and align the guardrails (**#6**) to the top 2 pre-drilled holes and the upper side rail (**#5**) to the bottom holes along the sides of those guardrails (**#3**).

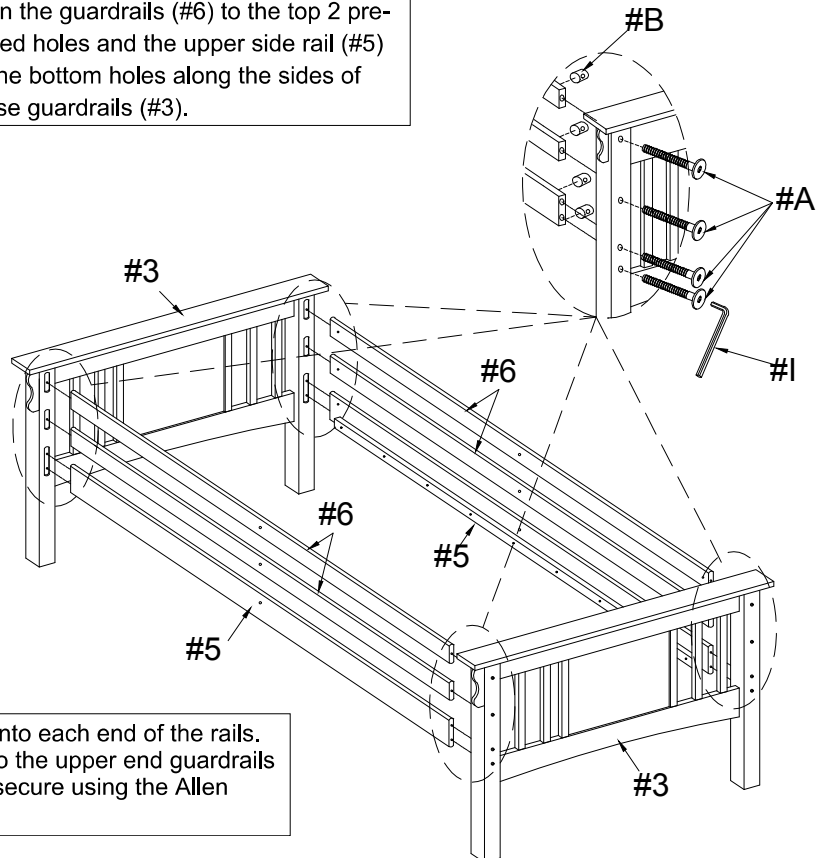

- 2a. Insert the barrel nuts (**#B**) into each end of the rails.
2b. Then insert 2 bolts (**#A**) into the upper end guardrails (**#3**) to lock with the rails, then secure using the Allen wrench (**#1**).

ASSEMBLY INSTRUCTIONS

5

Part #11 x 2pcs

Hardware #D x 6pcs

Hardware #J x 6pcs

Align the guardrail supports (#11) to the pre-drilled holes located along the sides of the upper side rails (#5) and guardrails (#6). Insert a total of 6 bolts (#D) and secure using the Allen wrench (#I)

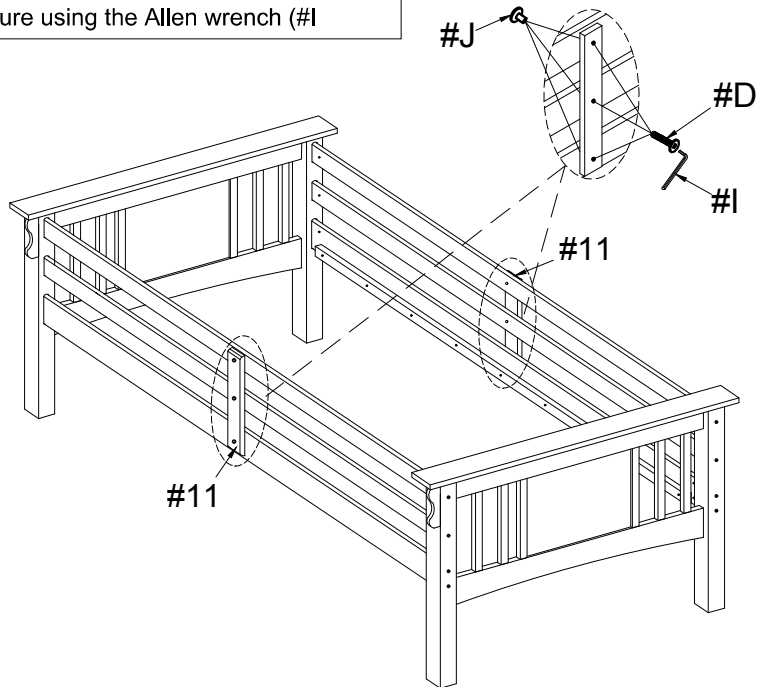

6

Part #10 x 2 Set

Hardware #C x 20pcs

Place the twin slat kit (#10) onto the upper side rails (#5). Align the ends of the slats to the pre-drilled holes located on the inner side of the upper side rails (#5). Insert a screw (#C) into each end and secure using a Phillips screwdriver.

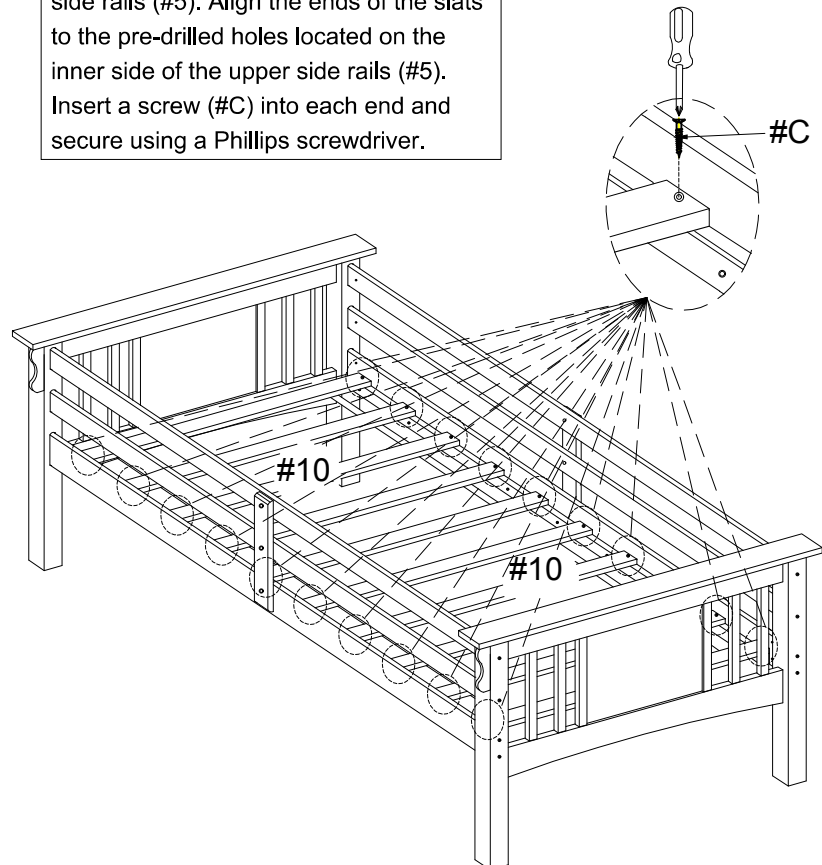

ASSEMBLY INSTRUCTIONS

7

Hardware **#G** x 4pcs

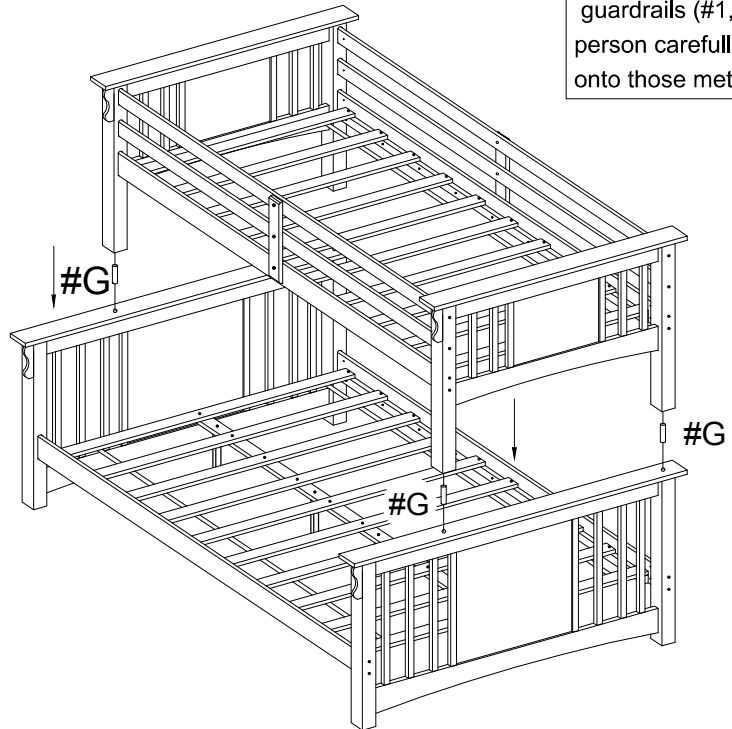

Insert a metal dowel (#G) into the large pre-drilled holes located on top of the lower end guardrails (#1,2). With the help of another person carefully place the upper bunk bed onto those metal dowels (#G).

8

Part **#12** x 5pcs

Part **#13** x 1pc

Part **#14** x 1pc

Hardware **#E** x 10pcs

Insert the ends of the ladder rung (#12) into the designated slots along the side of the ladder rails (#13,14). Insert 5 screws (#E) into each ladder rail and secure using the Allen wrench (#I).

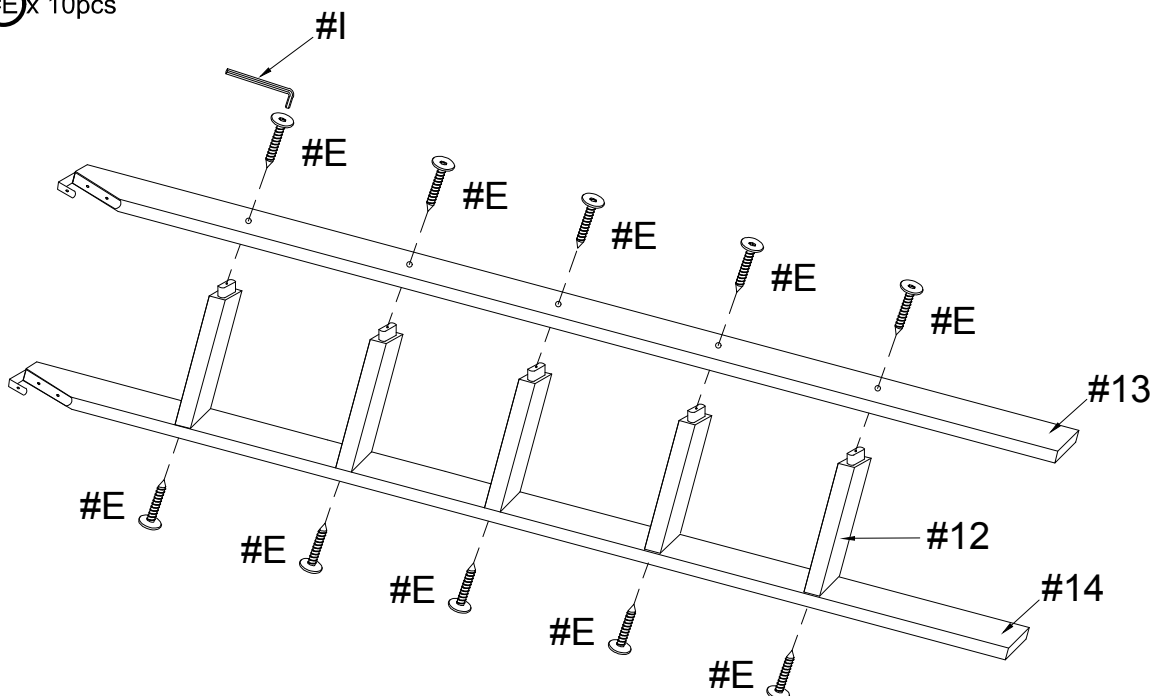

ASSEMBLY INSTRUCTIONS

9

Hardware  #H x 2pcs

Hook the top of the ladder rails onto the upper side rail (#5). Locate the pre-drilled holes on the inner side then align and insert 2 screws (#H). Secure using a Phillips screwdriver.

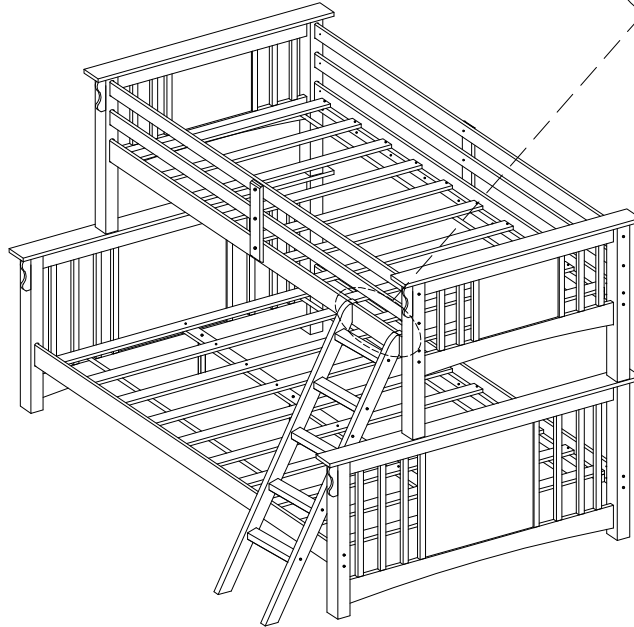
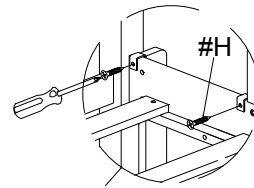

10

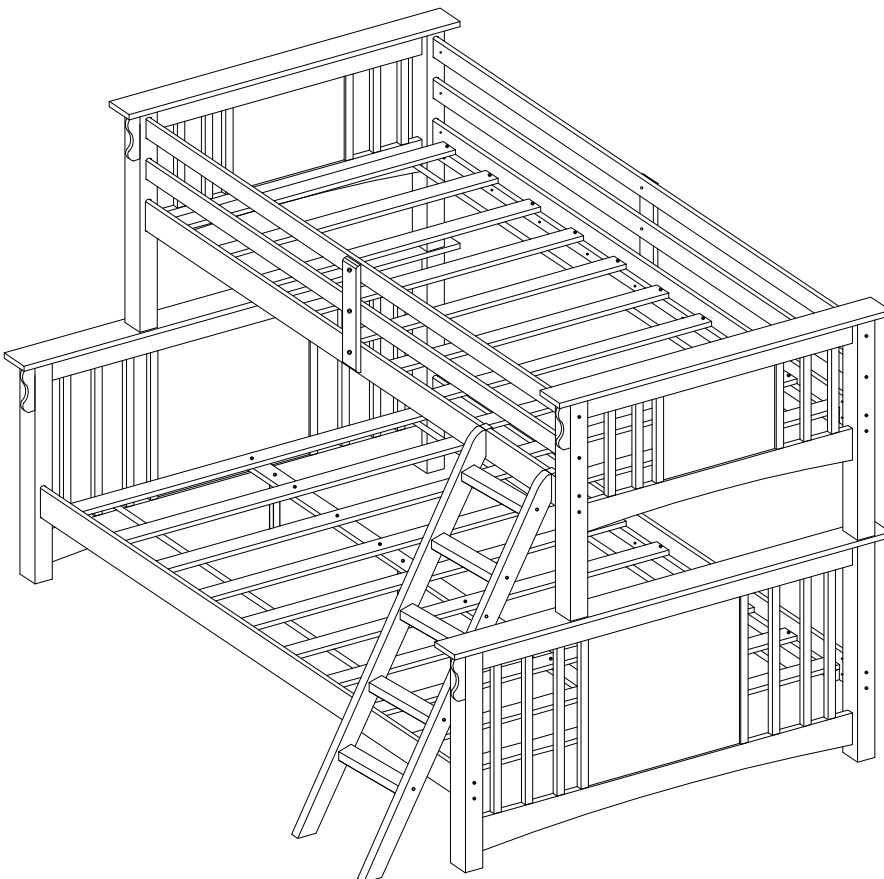

ASSEMBLY COMPLETED



Please ensure the furniture rests on an even and flat surface. If the product wobbles or feels loose, double-check all bolts and/or screws are properly tightened and secured.



Keep this handy!

Please retain this instruction manual and any order-related information for future reference.



Lift, don't drag!

To avoid damage to product please always LIFT the product when transporting or adjusting the placement.

Safety Warnings for Bunk Beds

1. Read and follow the information on the WARNINGS shown on the end structure of the upper bunk and on the carton.
2. Do not remove warning label from the bed.
3. Keep these instructions for future reference.
4. **IMPORTANT: Must use Bunkie mattress or Bunkie board.** The proper sizes for the **UPPER/LOWER TWIN-SIZE** Bunkie mattress or Bunkie board should be 74" long and 37½" - 38½" wide with no more than 6" thickness and for the **UPPER/LOWER FULL-SIZE** should be 74" long and 53" - 54" wide with no more than 6" thickness.
5. Surface of mattress must be at least 5 inches (127 mm) **BELOW** the upper edge of guardrails.
6. The **MAXIMUM** weight capacity for the upper bunk is not to exceed 175 lbs.
7. Do not allow children under 6 years of age to use the upper bunk.
8. Periodically check and ensure that the guardrails, ladder, handle and other components are in their proper position, free from damage, and that all connectors are tightened and secured.
9. **DO NOT** allow horseplay, rough playing or jumping on the beds and do not allow playing or hiding under the beds.
10. Always use the ladder for entering or leaving the upper bunk.
11. Do not use substitute parts. Contact the manufacturer or dealer for replacement parts.
12. Use of a nightlight may provide added safety precaution for a person using the upper bunk.
13. Always use the guardrails on both sides of the upper bunk.
14. If the bunk bed will be placed next to a wall, the guardrail that runs the full length of the bed should be placed against the wall to prevent entrapment between the bed and the wall.
15. The use of water or sleep flotation mattresses is prohibited.
16. No more than one person is allowed on the upper bunk at all times.



WARNING: STRANGULATION HAZARD

Never attach or hang objects to any part of the bunk bed that are not designed for use with the bed. Objects such as hanger, hook, belt, bag, rope, string, etc. should not be used on or around the bunk bed.