

# RECLINER CHAIR ASSEMBLY INSTRUCTIONS

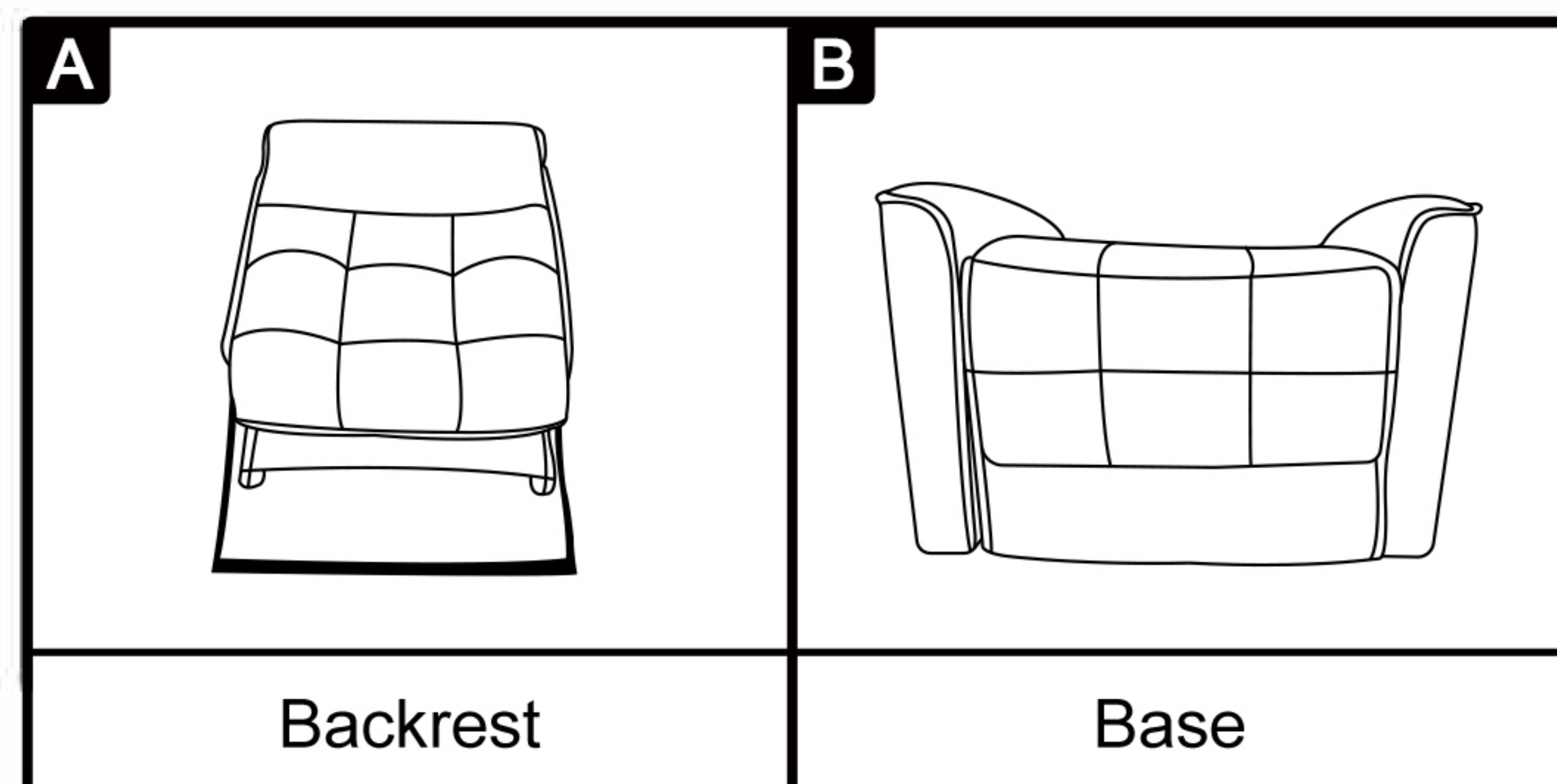

Send your order number to our after-sales service to get

- ① One-year warranty provided
  - ② Whether satisfied or not, please contact us so we can make improvements and ensure your optimal experience.
  - ③ Consultation on product installation and usage
- After-sales mailbox: [hztycservice@outlook.com](mailto:hztycservice@outlook.com)  
After-sales contact number: [855-510-1437](tel:855-510-1437)



Step 1: Insert the recliner backrest A into the seat base B slide rail, make sure to align and push the top part in until you hear "click".

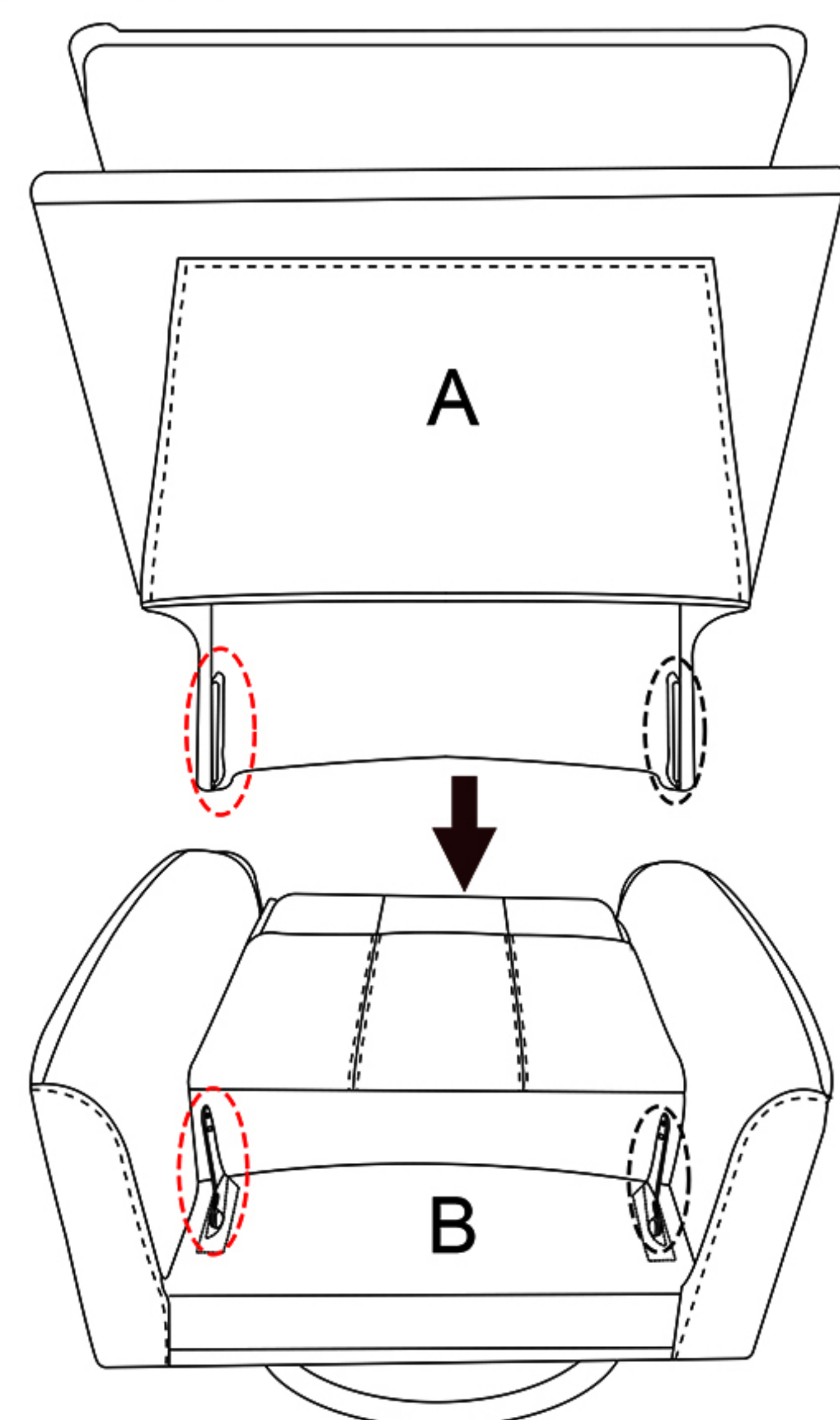

Step 2: Enjoy leisure time!

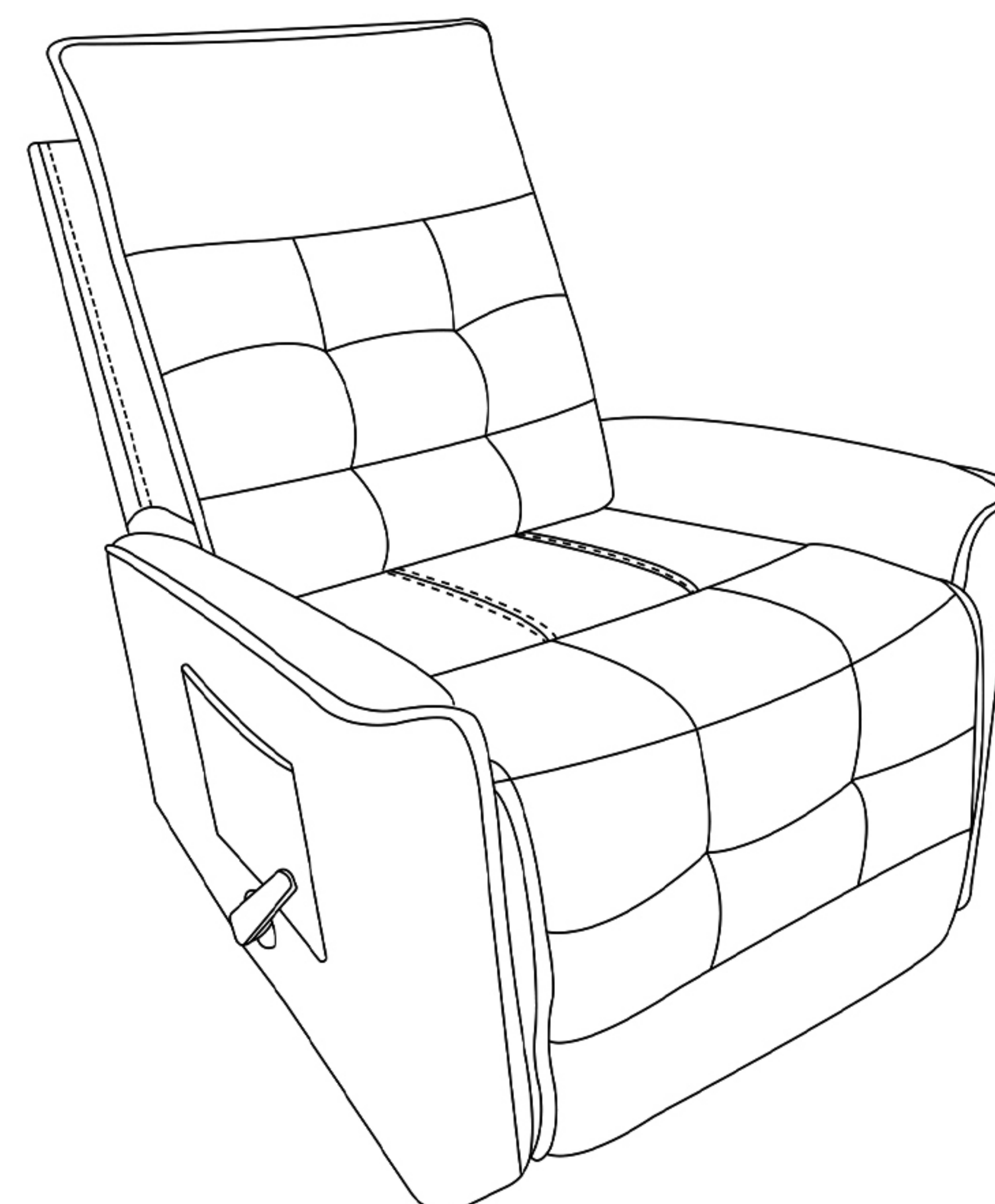

Scan QR Code  
Email Address

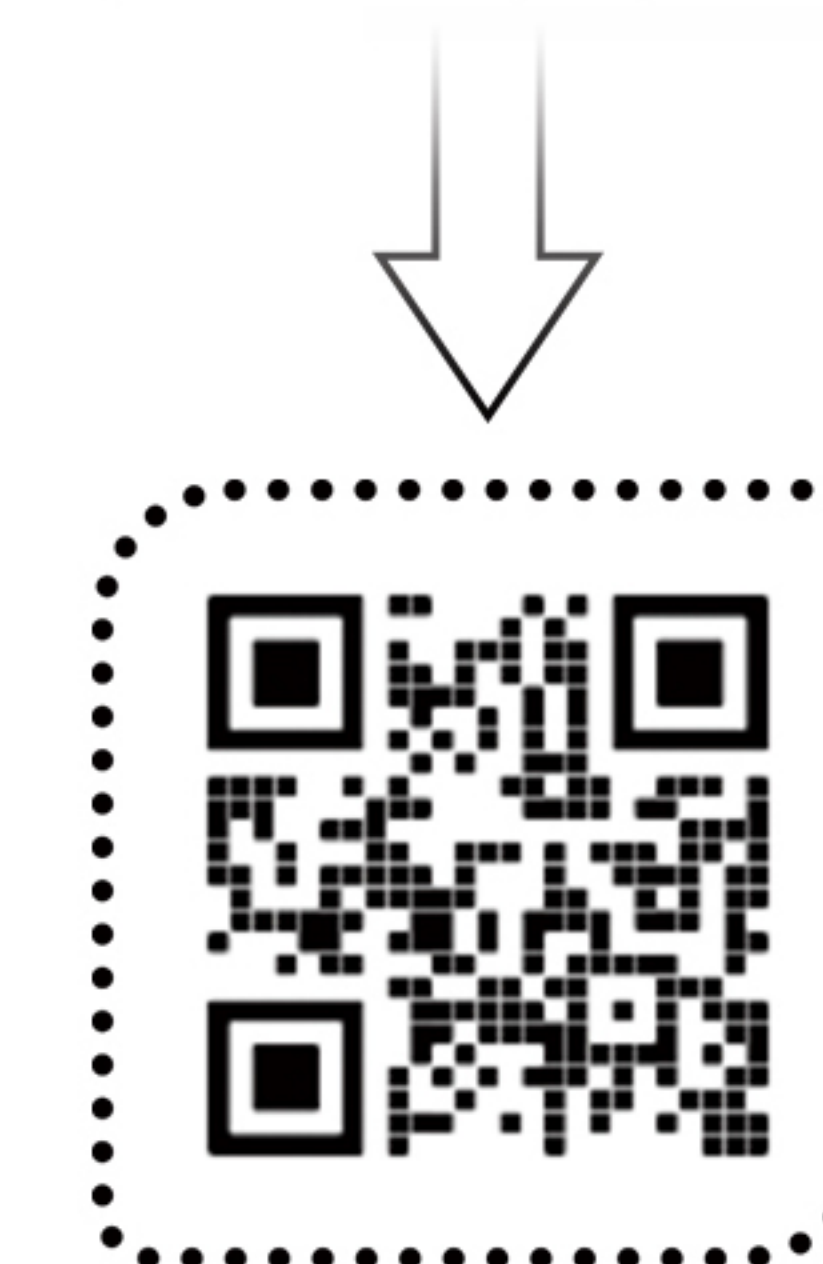

## Warm tips:

1. If you encounter the footrest of the recliner not opening and closing smoothly when first used, this is a normal phenomenon. Just use it more often to undergo a breaking-in period.
2. Please use the recliner on a flat surface or a carpet to avoid instability in the center of gravity.
3. Please contact our after-sales service team if you have any questions, we will be the first time for you to deal with the problem!

# RECLINER CHAIR ASSEMBLY INSTRUCTIONS

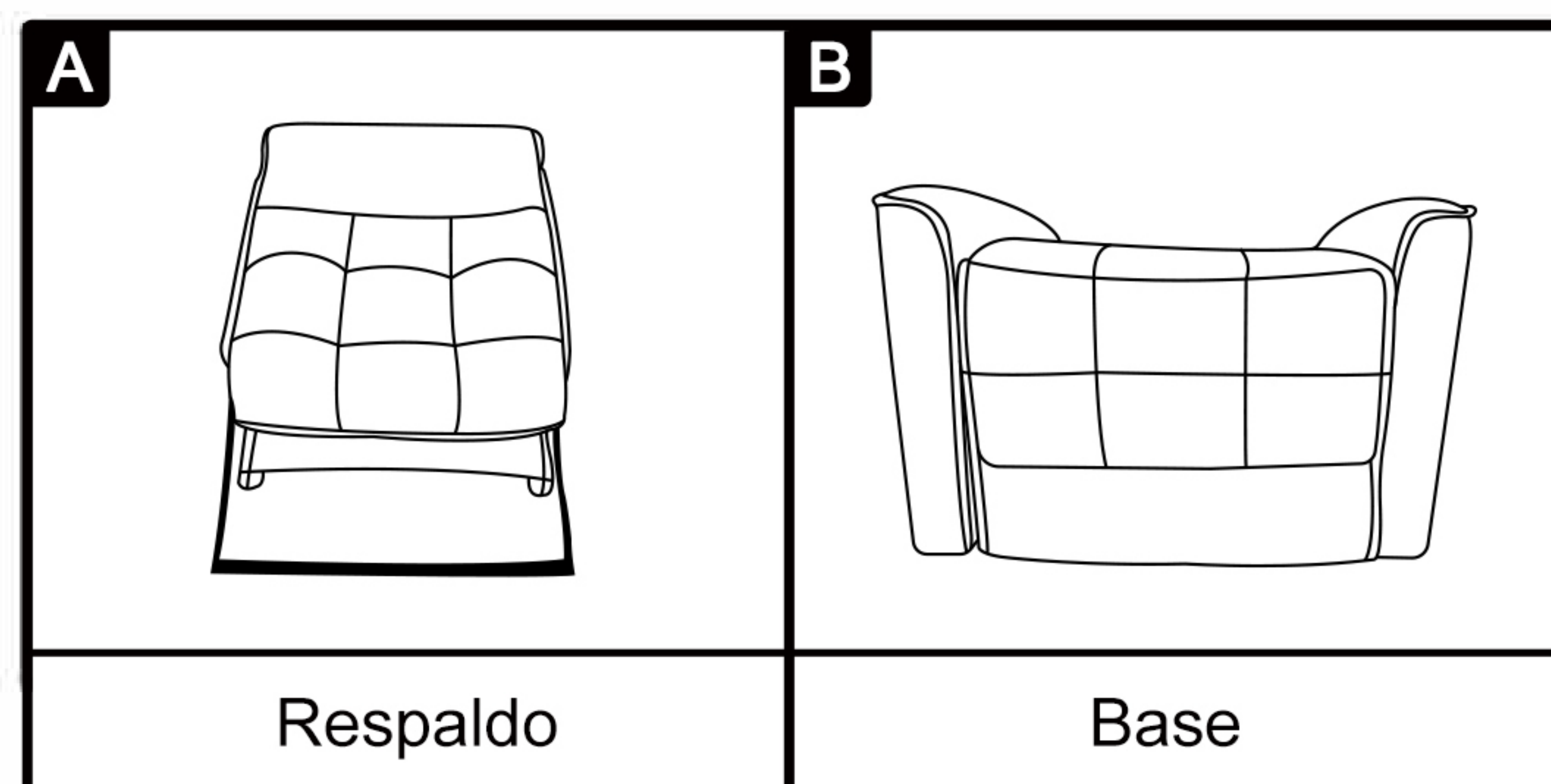

Envíe su número de pedido a nuestro servicio posventa para obtener

- ① Garantía de un año.
  - ② Contáctenos, satisfecho o no, para que podamos mejorar y optimizar su experiencia.
  - ③ Consultas sobre instalación y uso del producto
- Buzón de posventa: [hztycservice@outlook.com](mailto:hztycservice@outlook.com)  
Número de contacto posventa: [855-510-1437](tel:855-510-1437)



Paso 1: Inserte el respaldo de la silla reclinable A en la guía deslizante del asiento base B, asegúrese de alinear y empuje hasta escuchar un "clic".

Paso 2: Disfrutando de tiempo de ocio!

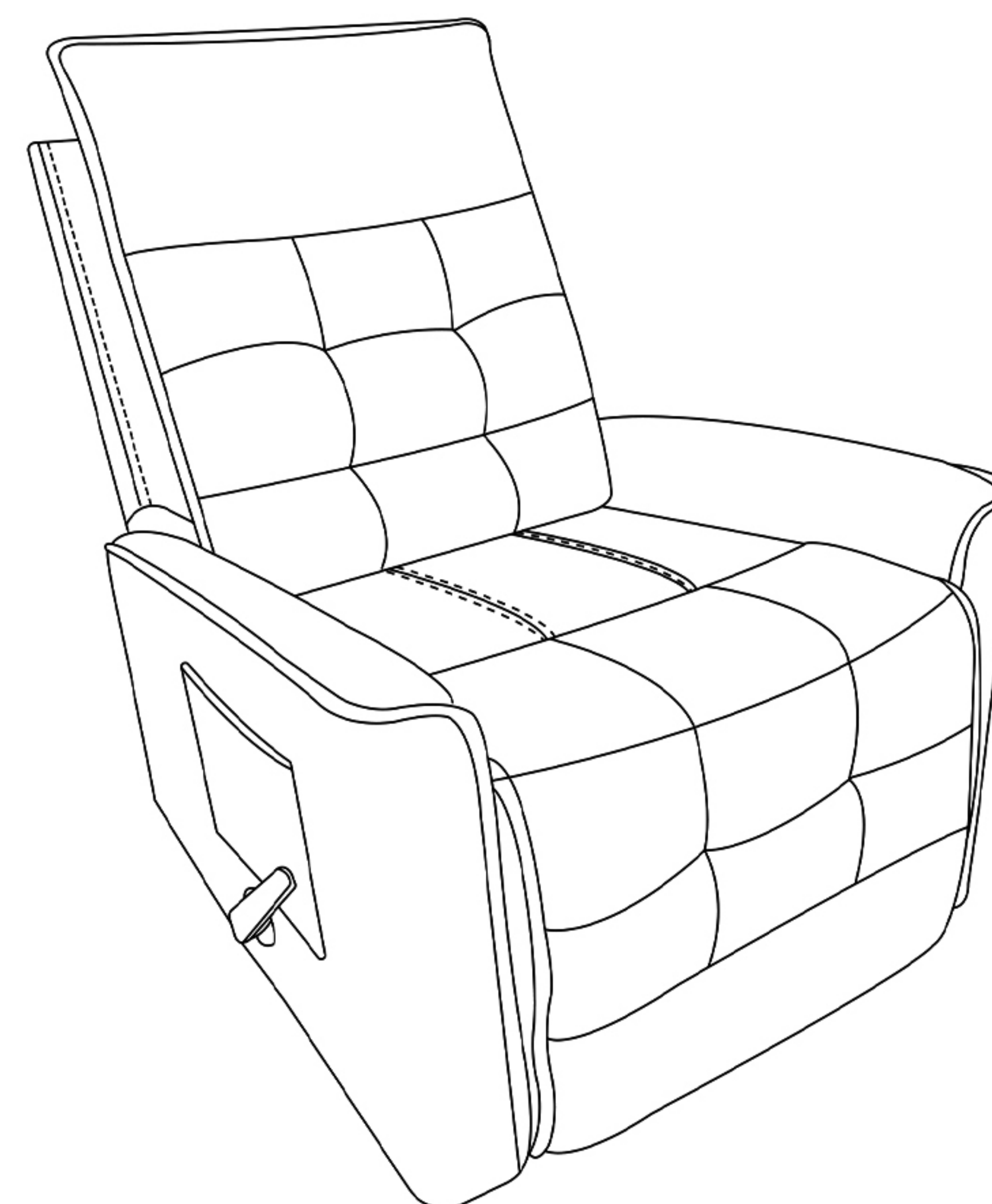
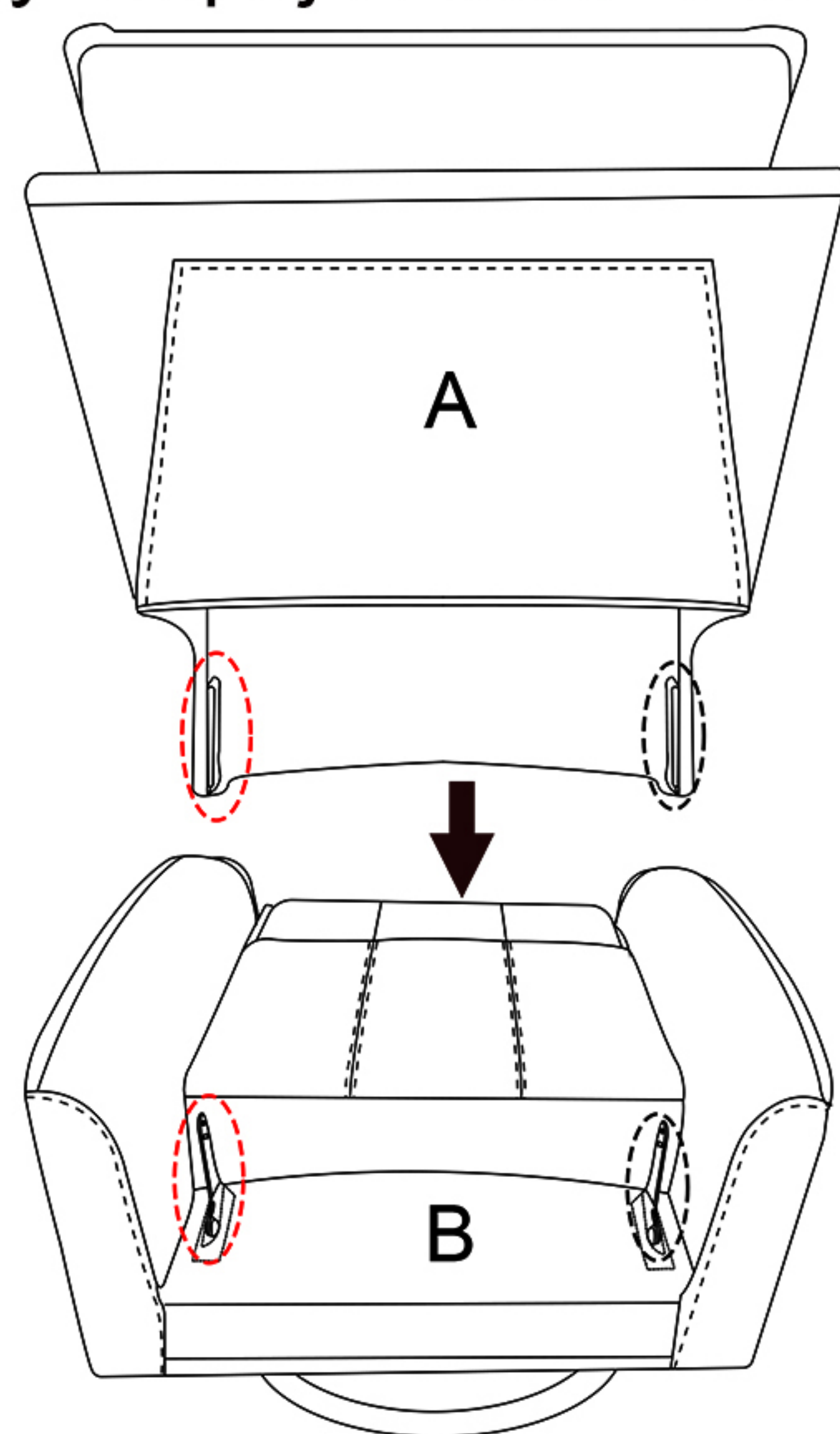

Escanee código QR - Dirección de correo electrónico

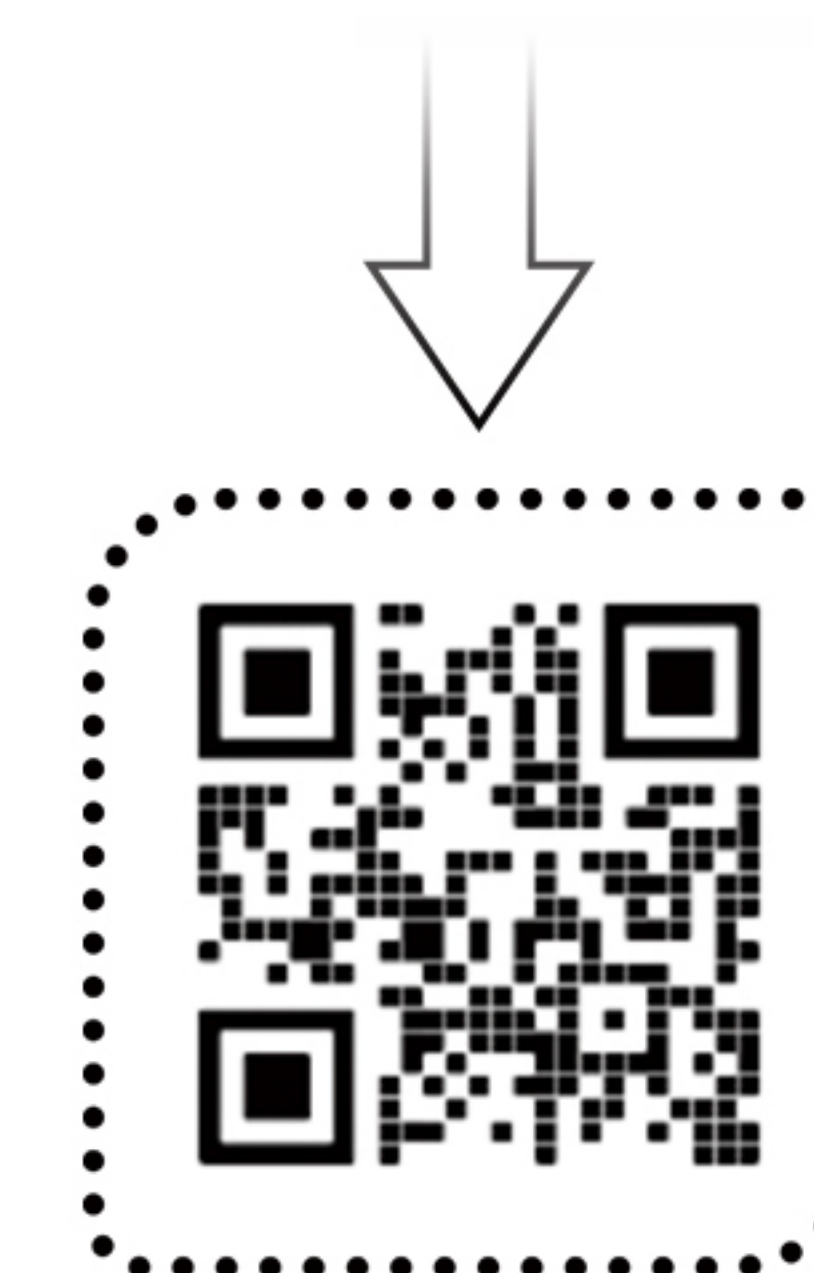

## Consejos útiles:

1. Si encuentras que el reposapiés del sillón reclinable no se abre y cierra suavemente cuando se usa por primera vez, esto es un fenómeno normal. Solo úsalo más a menudo para pasar por un período de adaptación.
2. Por favor, utiliza el sillón reclinable en una superficie plana o una alfombra para evitar la inestabilidad en el centro de gravedad.
3. Por favor, ponte en contacto con nuestro equipo de servicio postventa si tienes alguna pregunta, ¡seremos los primeros en ayudarte a resolver el problema!

# INSTRUCTIONS DE MONTAGE DU FAUTEUIL INCLINABLE

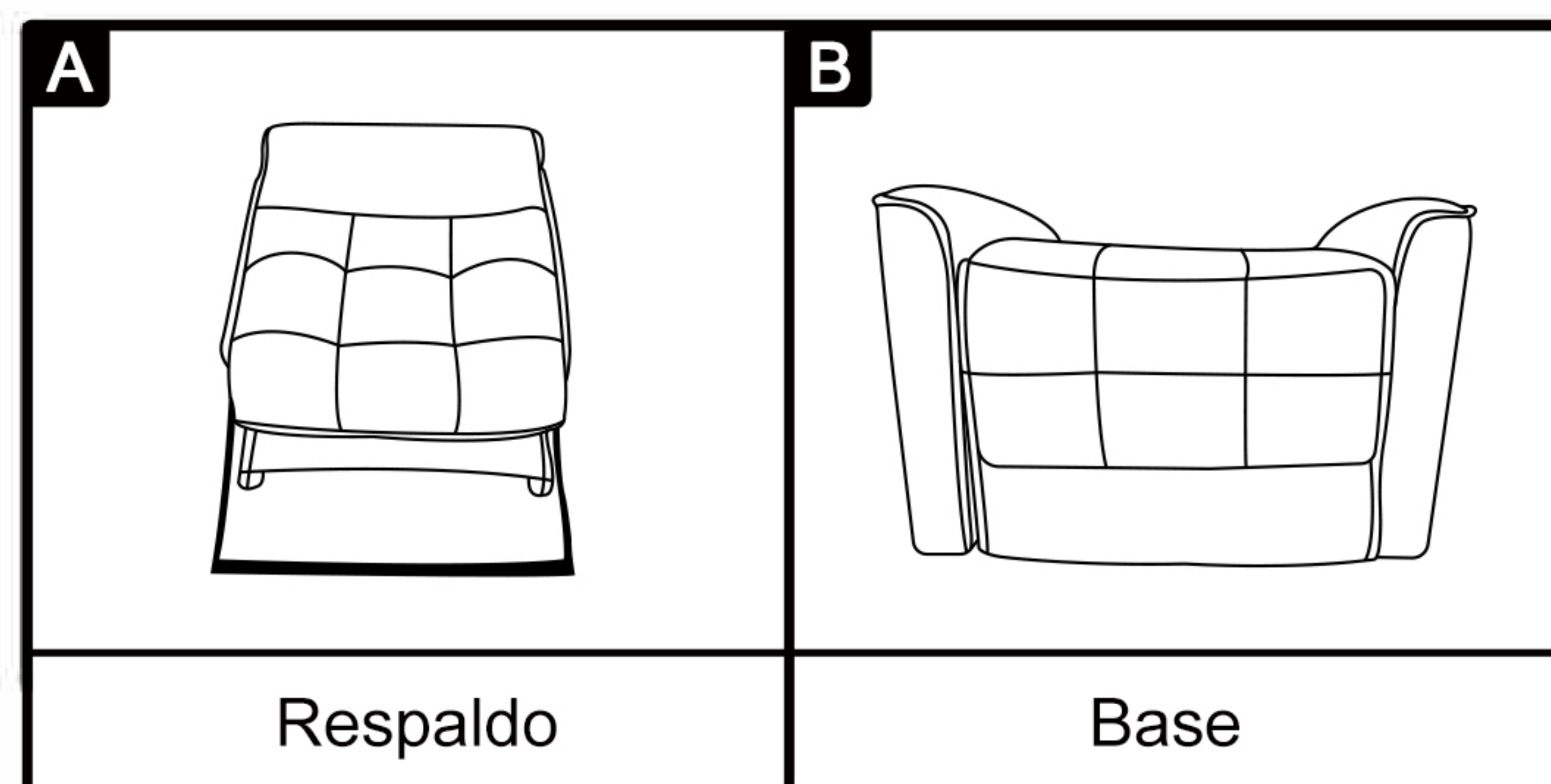

Envoyez votre numéro de commande à notre service après-vente pour obtenir

- ① Garantie d'un an.
- ② Que vous soyez satisfait ou non, contactez-nous pour nous permettre d'améliorer le produit et votre expérience.
- ③ Assistance pour l'installation et l'utilisation du produit.

Boîte aux lettres après-vente: [hztycservice@outlook.com](mailto:hztycservice@outlook.com)

Numéro de contact après-vente: [855-510-1437](tel:855-510-1437)



Étape 1: Insérez le dossier du fauteuil inclinable A dans le rail de la base du siège B, assurez-vous qu'il est aligné et poussez jusqu'à entendre un "clic".

Étape 2: Profitez du temps libre!

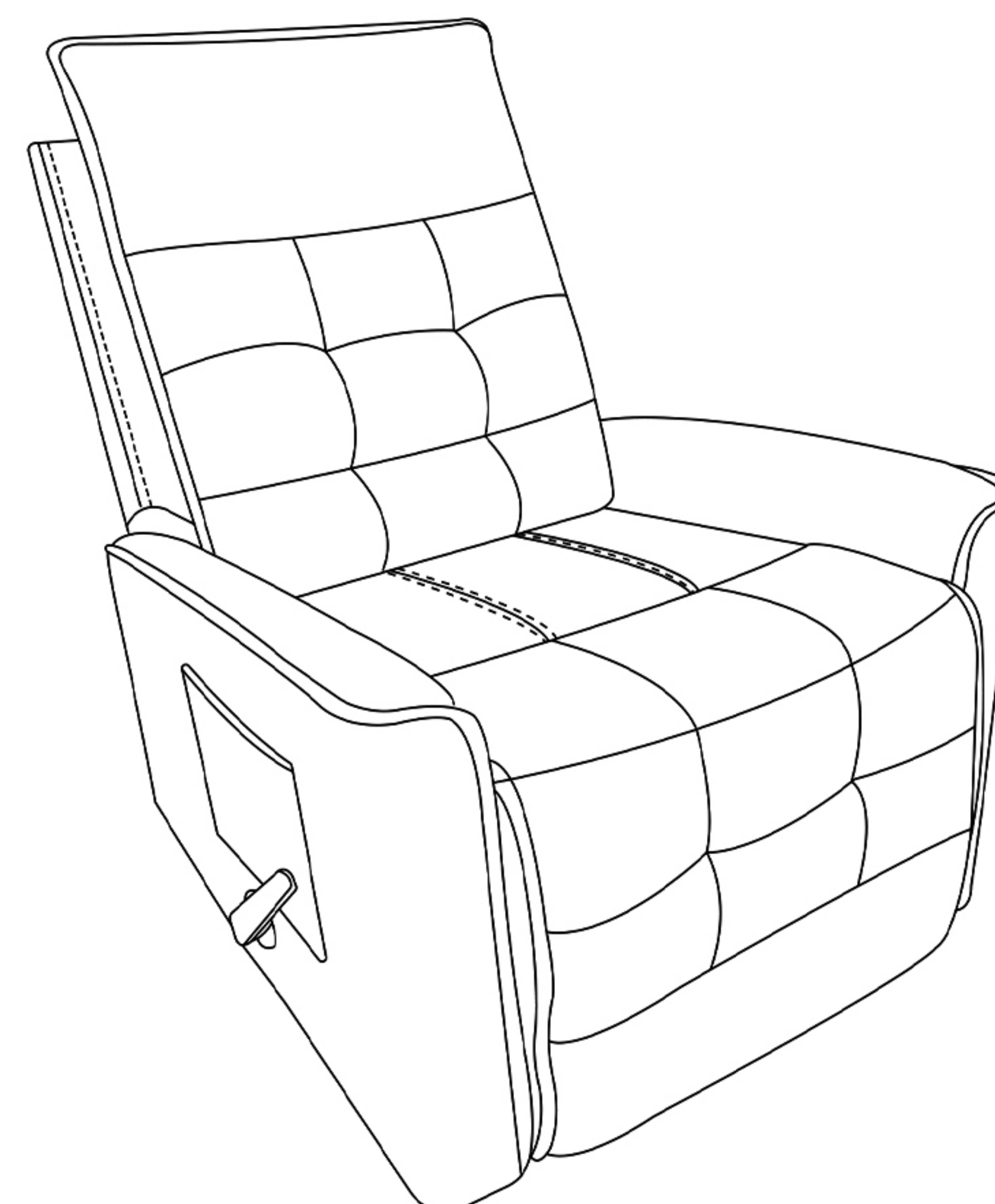
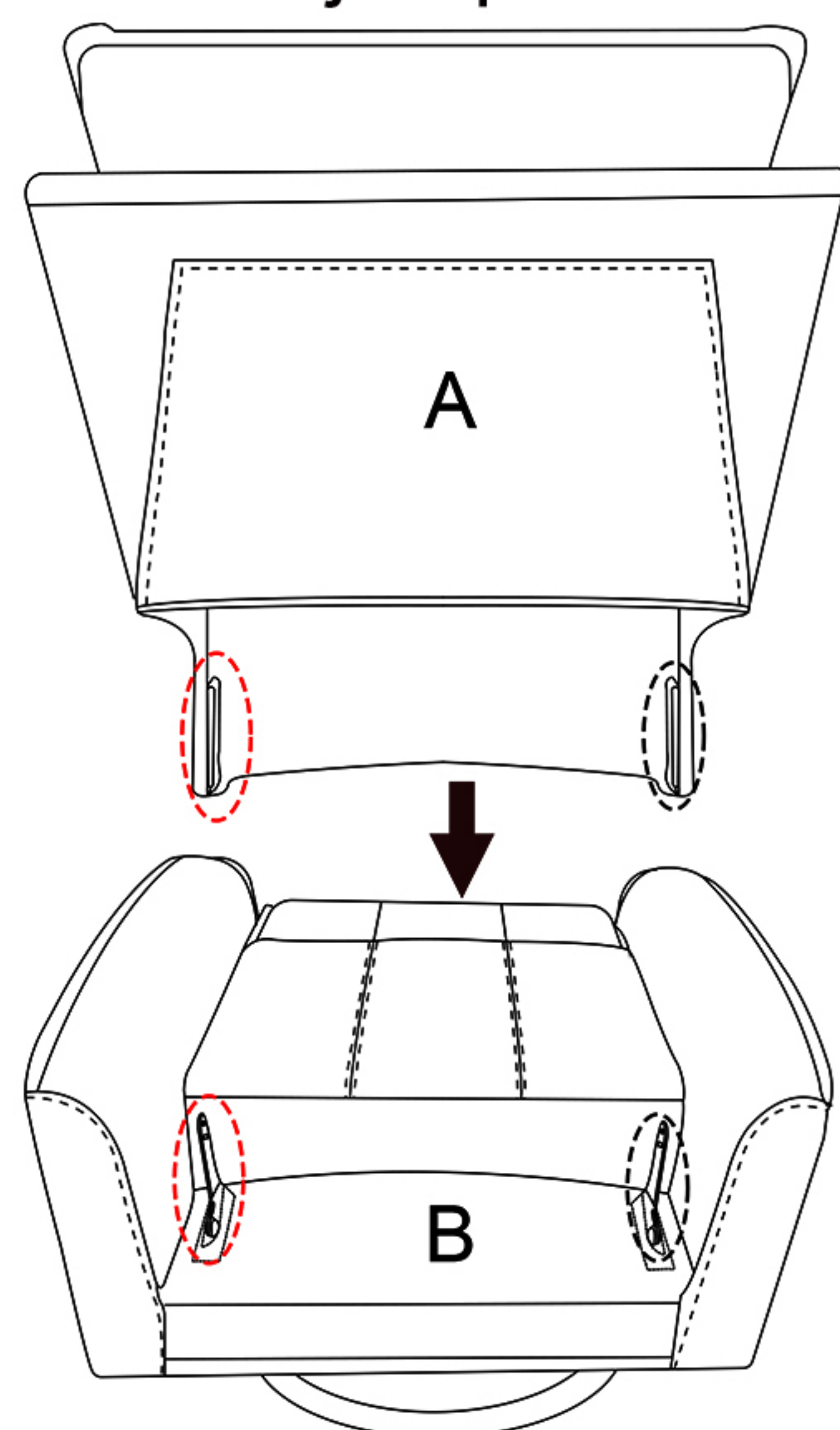

Scanner le QR code -  
Adresse e-mail

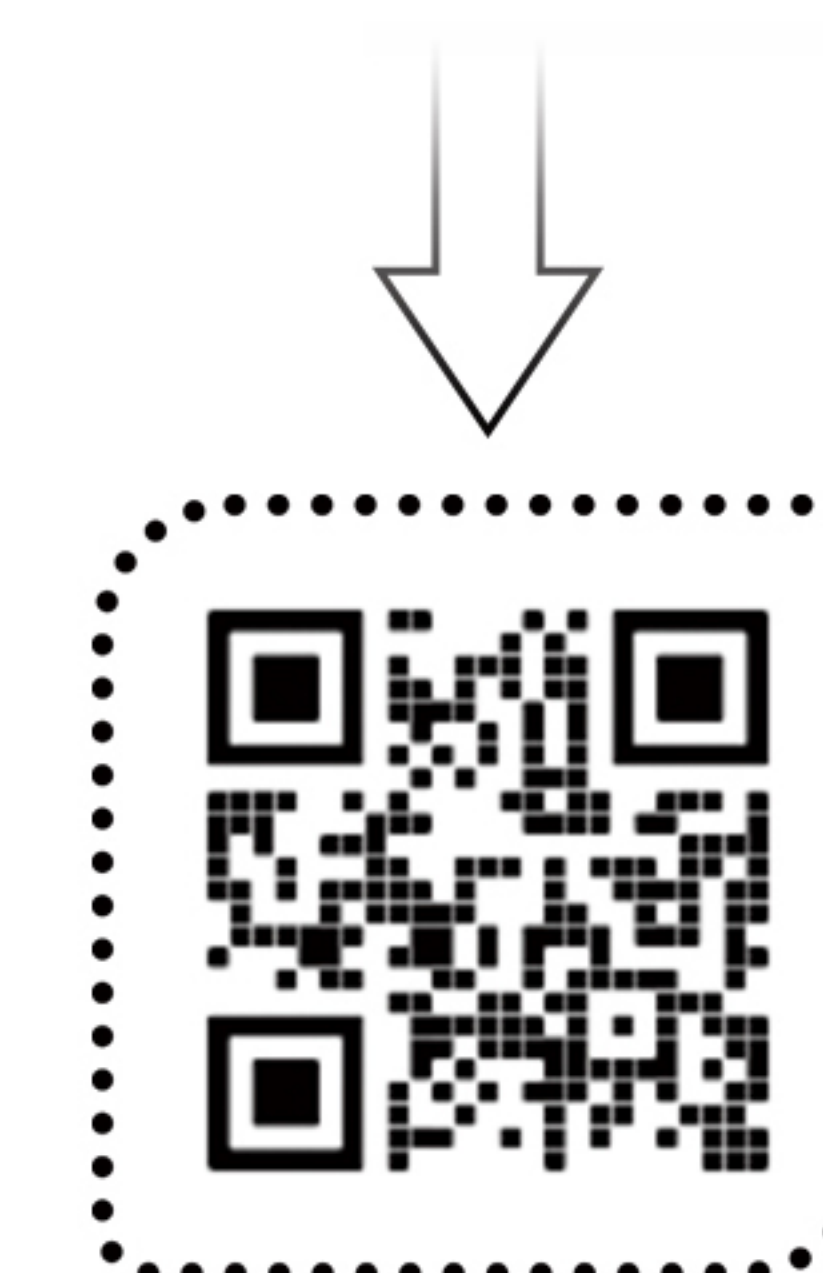

## Conseils chaleureux:

1. Si vous rencontrez des difficultés avec le repose-pieds du fauteuil inclinable qui ne s'ouvre pas et ne se ferme pas en douceur lors de la première utilisation, c'est un phénomène normal. Utilisez-le simplement plus souvent pour qu'il subisse une période de rodage.
2. Veuillez utiliser le fauteuil inclinable sur une surface plane ou sur un tapis pour éviter toute instabilité au niveau du centre de gravité.
3. Veuillez contacter notre équipe de service après-vente si vous avez des questions, nous traiterons le problème pour vous dans les plus brefs délais!

# ISTRUZIONI PER L'ASSEMBLAGGIO DELLA POLTRONA RECLINABILE

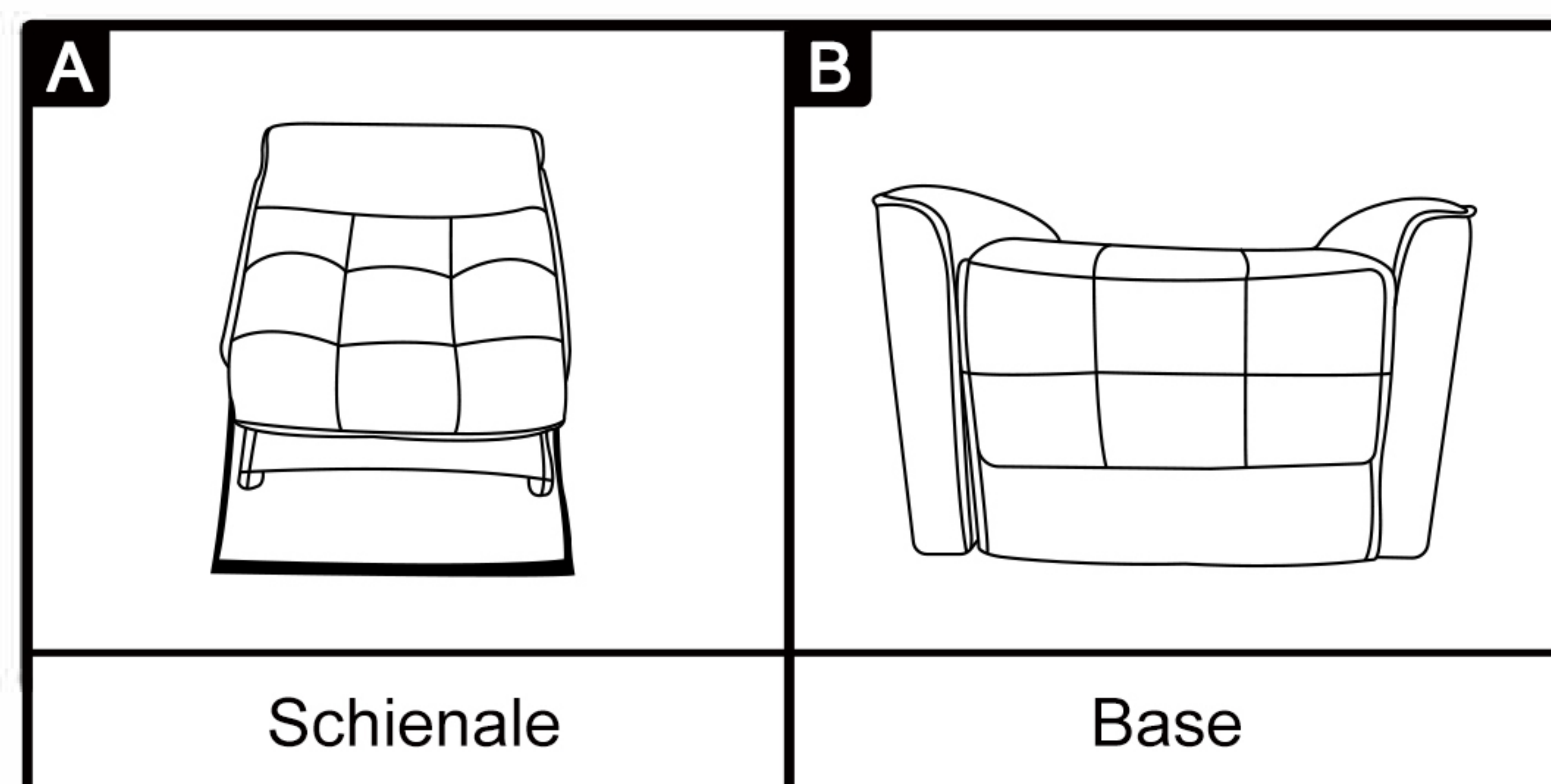

Inviare il numero d'ordine al nostro servizio post-vendita per ottenere

- ① Garanzia di un anno.
- ② Che siate soddisfatti o meno, contattateci per permetterci di migliorare e ottimizzare la vostra esperienza.
- ③ Consultazioni su installazione e utilizzo del prodotto.

Email del servizio post-vendita: [hztycservice@outlook.com](mailto:hztycservice@outlook.com)

Numero di contatto del servizio post-vendita: [855-510-1437](tel:855-510-1437)



Passo 1: Inserire il poggiatesta della poltrona A nei binari della base della sedia B, assicurarsi che sia allineato e spingere fino a sentire un "clic".

Passo 2: Godersi del tempo libero!

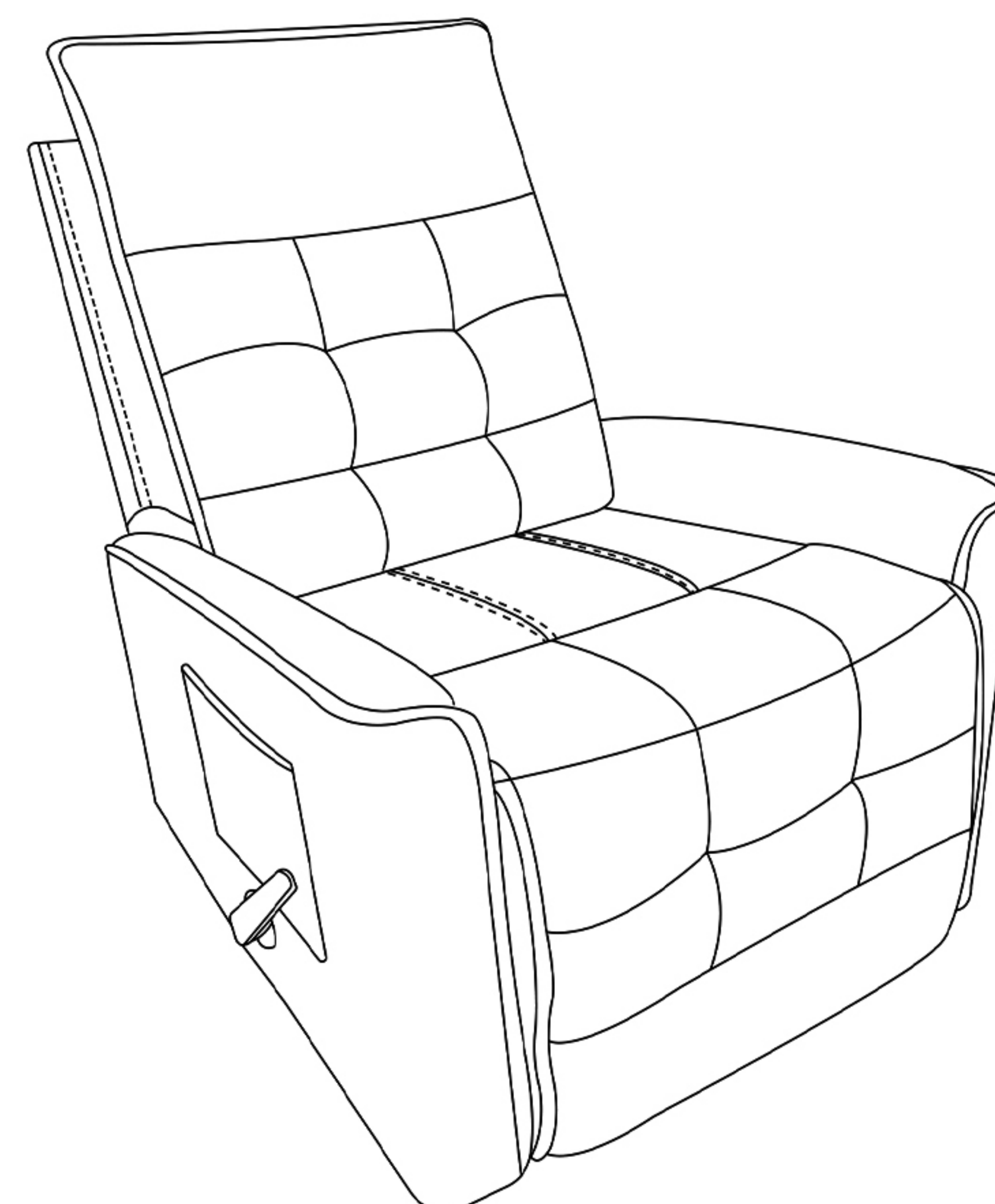
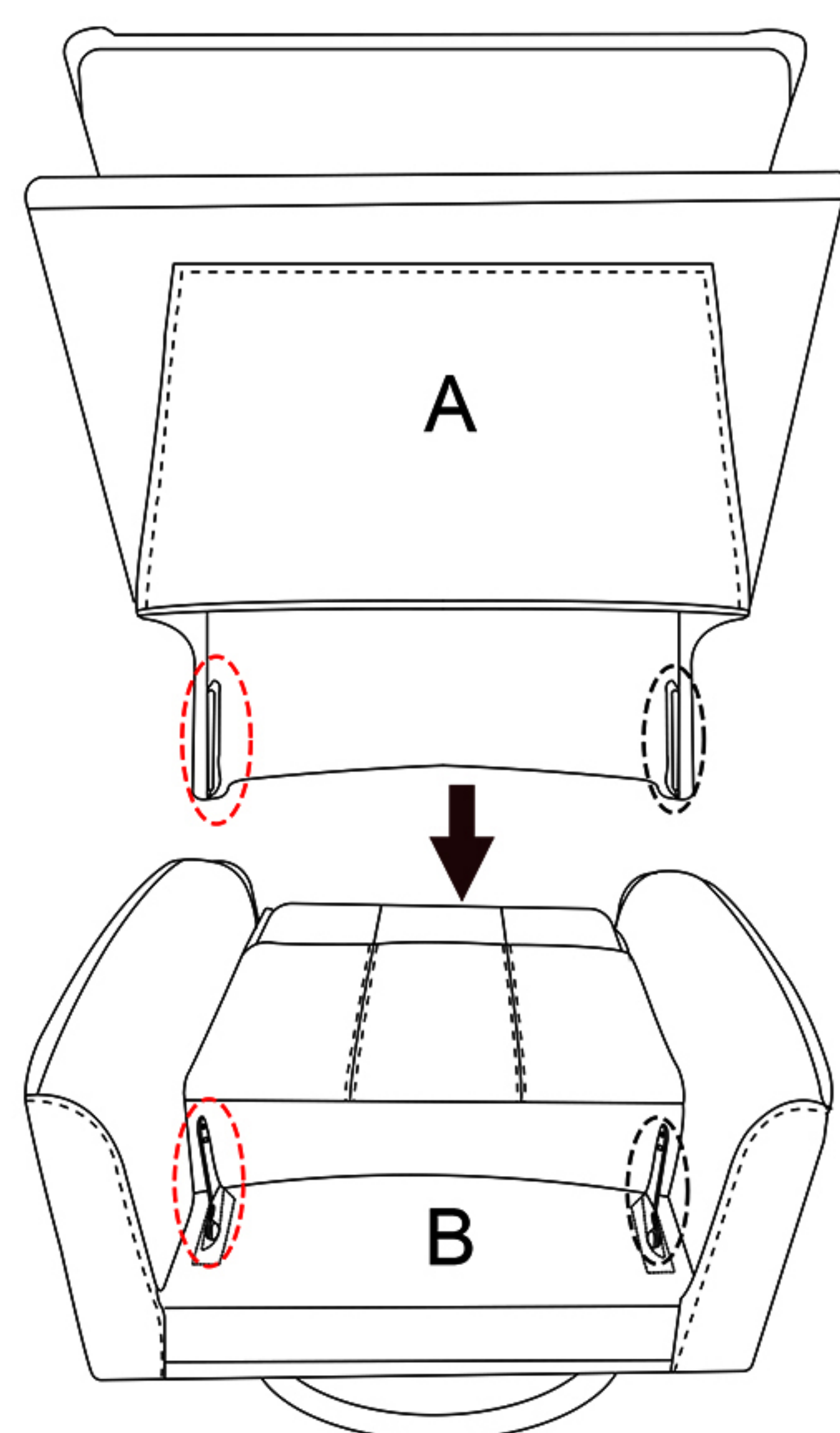

Scansiona il codice QR - Indirizzo email

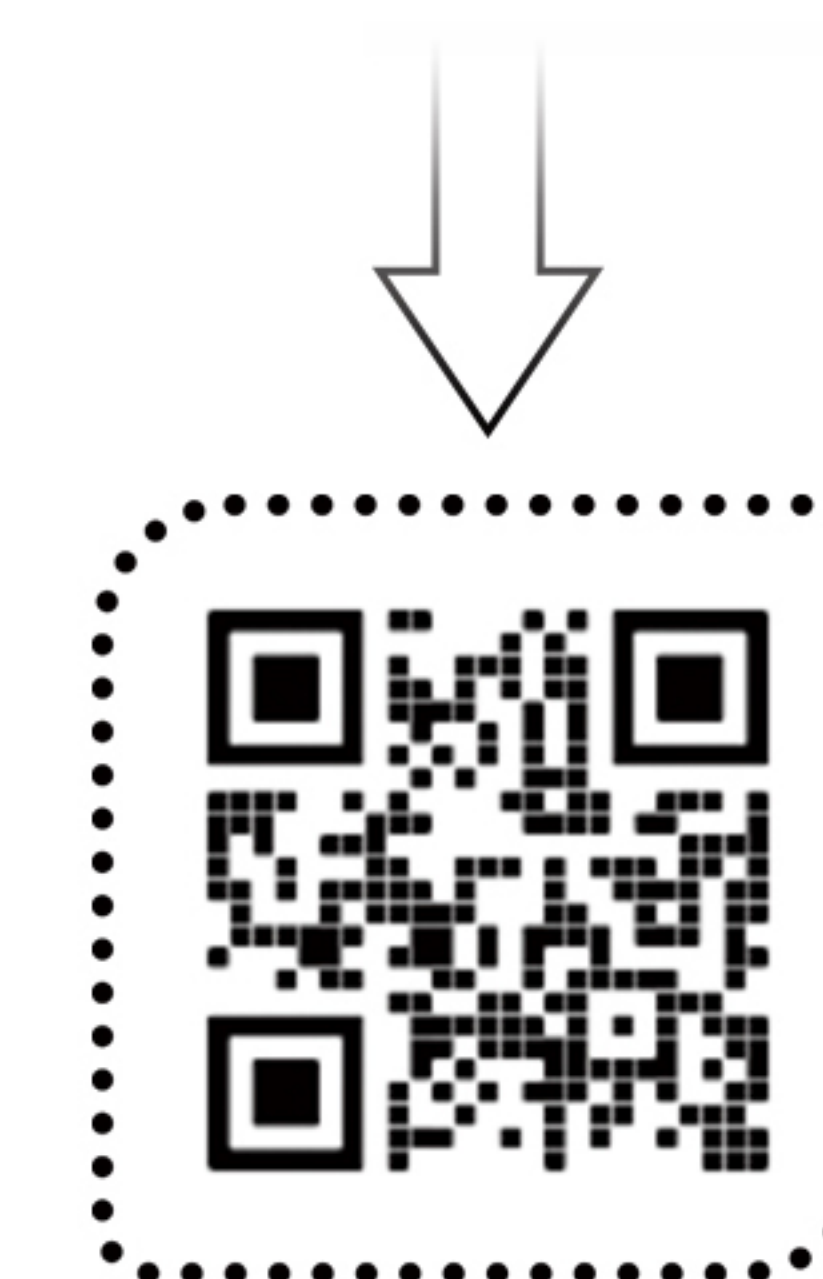

## Suggerimenti utili:

1. Se incontri il poggiatesta della poltrona reclinabile che non si apre e si chiude facilmente quando viene utilizzato per la prima volta, questo è un fenomeno normale. Usalo più spesso per un periodo di rodaggio.
2. Si prega di utilizzare la poltrona reclinabile su una superficie piana o su un tappeto per evitare instabilità nel centro di gravità.
3. Si prega di contattare il nostro team di assistenza post-vendita se hai domande, saremo i primi a gestire il problema per te!

# RELAXSESSEL MONTAGEANLEITUNG

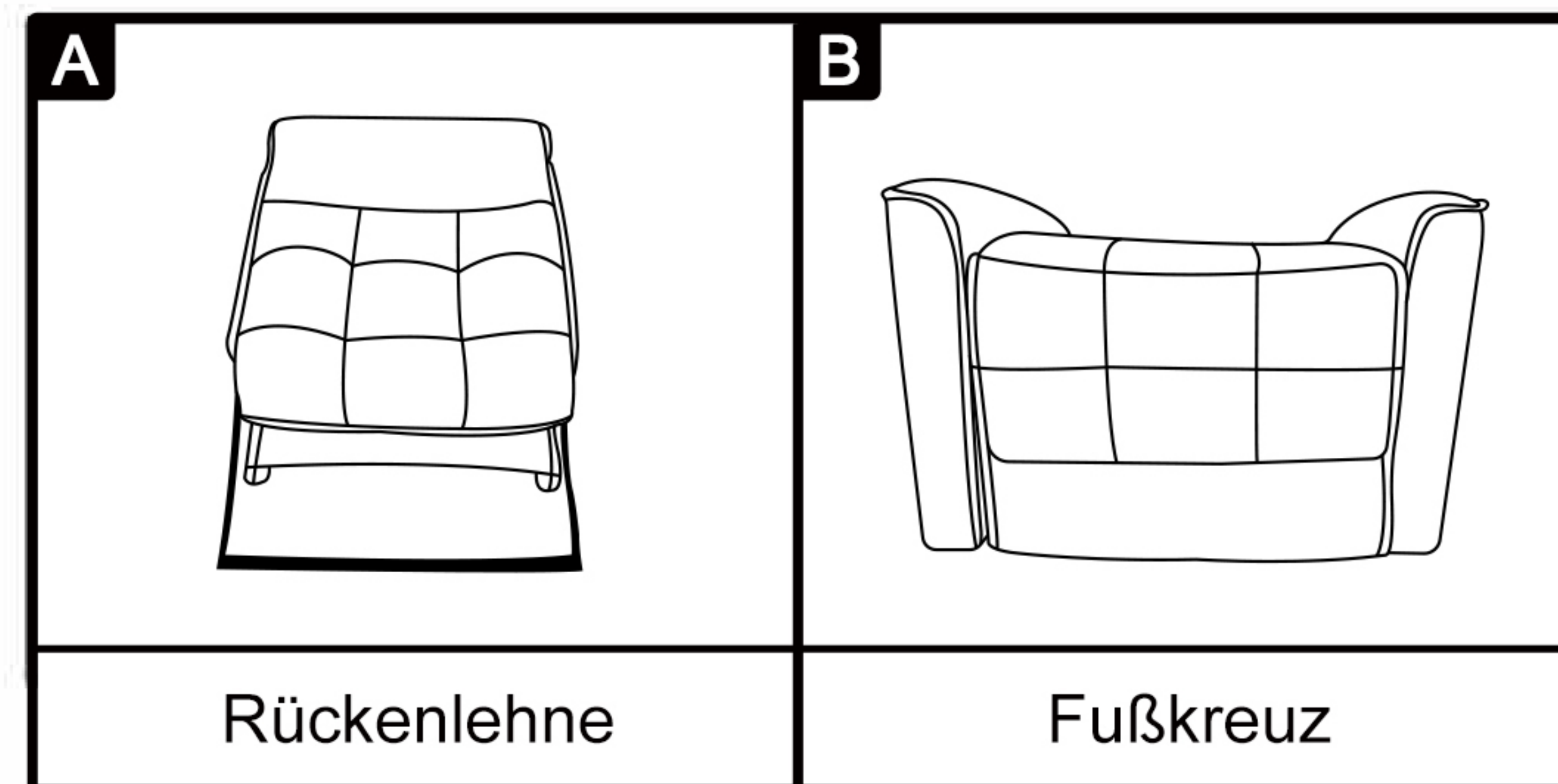

Senden Sie Ihre Bestellnummer an unseren Kundendienst, um Folgendes zu erhalten

- ① Einjährige Garantie.
- ② Kontaktieren Sie uns – ob zufrieden oder nicht – damit wir Verbesserungen vornehmen und Ihr Erlebnis optimieren können.
- ③ Beratung zur Produktinstallation und -anwendung.

Kundendienst-E-Mail: [hzytcservice@outlook.com](mailto:hzytcservice@outlook.com)

Kundendienst-Telefonnummer: [855-510-1437](tel:855-510-1437)



Schritt 1: Setzen Sie die Rückenlehne A des Liegestuhls in die Schienen des Sitzesockels B ein, richten Sie sie aus und drücken Sie sie, bis Sie ein "Klick" hören.

Schritt 2: Genießen Sie Ihre Freizeit!

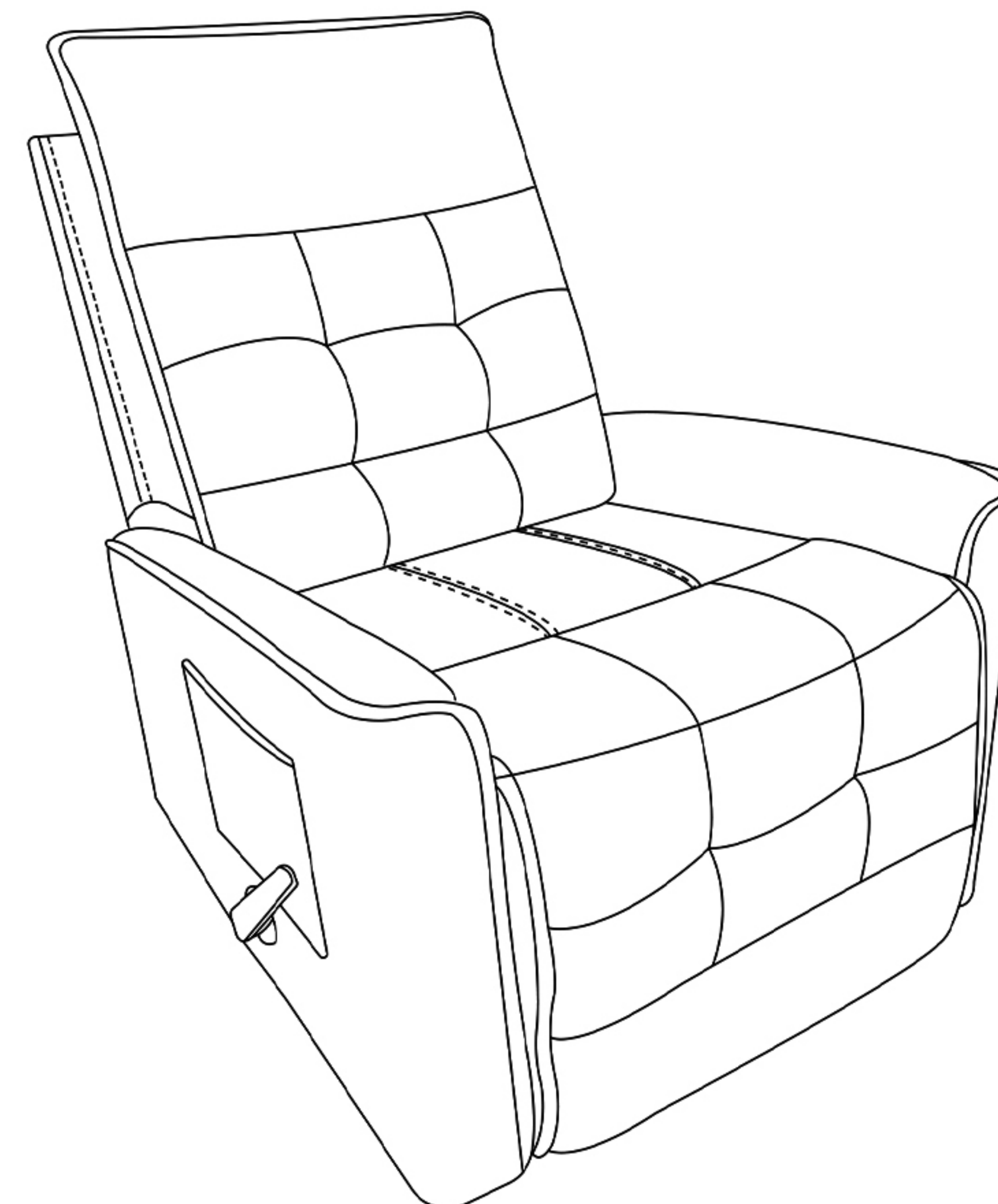
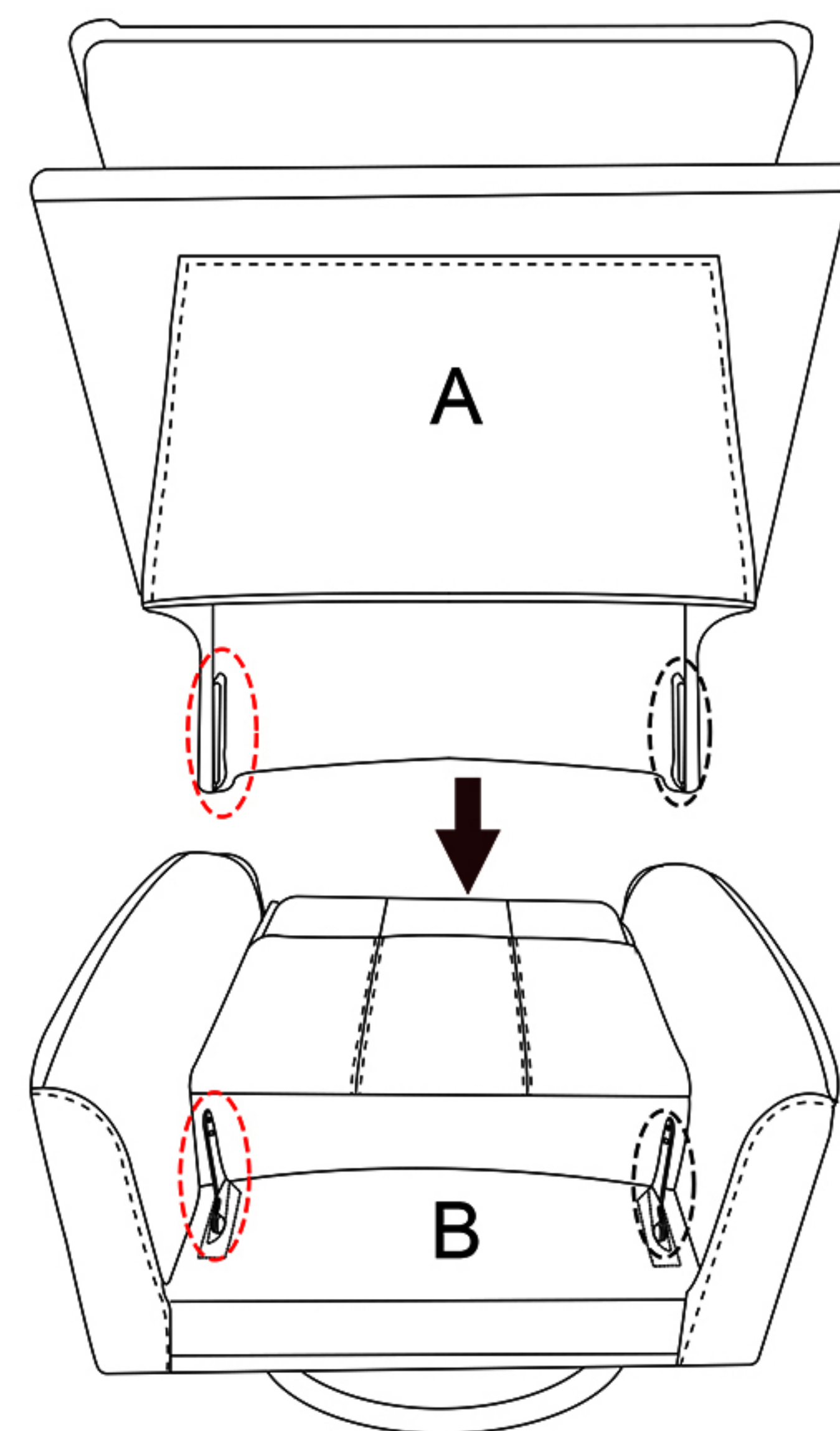

QR-Code scannen -  
E-Mail-Adresse

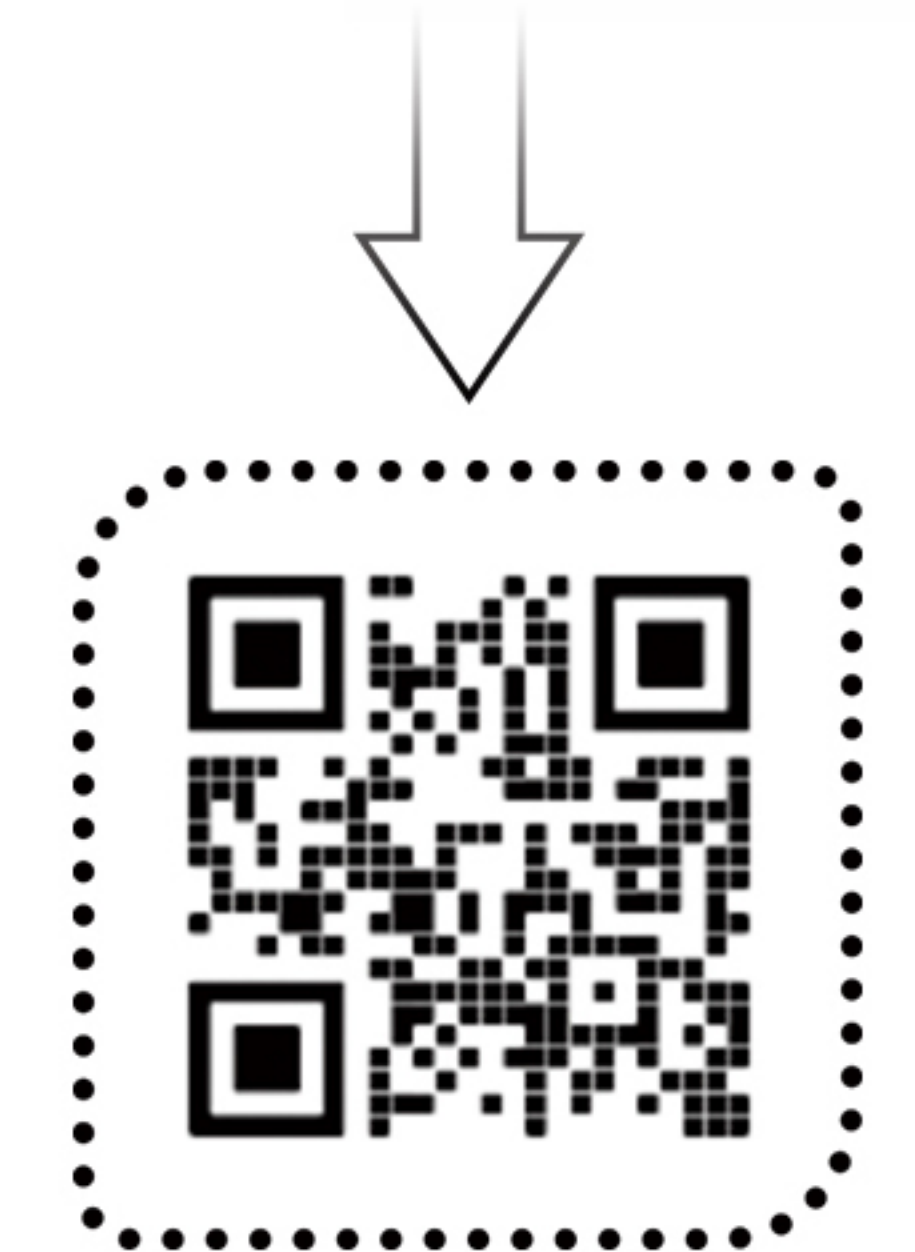

## Warme Tipps:

1. Wenn Sie beim ersten Gebrauch feststellen, dass sich die Fußstütze des Liegesessels nicht reibungslos öffnen und schließen lässt, handelt es sich um ein normales Phänomen. Verwenden Sie sie einfach öfter, um eine Einlaufzeit zu durchlaufen.
2. Verwenden Sie den Liegesessel bitte auf einer ebenen Fläche oder einem Teppich, um Instabilität im Schwerpunkt zu vermeiden.
3. Bitte kontaktieren Sie unser Kundendienstteam, wenn Sie Fragen haben. Wir werden das Problem für Sie beim ersten Mal bearbeiten!

# 리클라이너 조립 지침

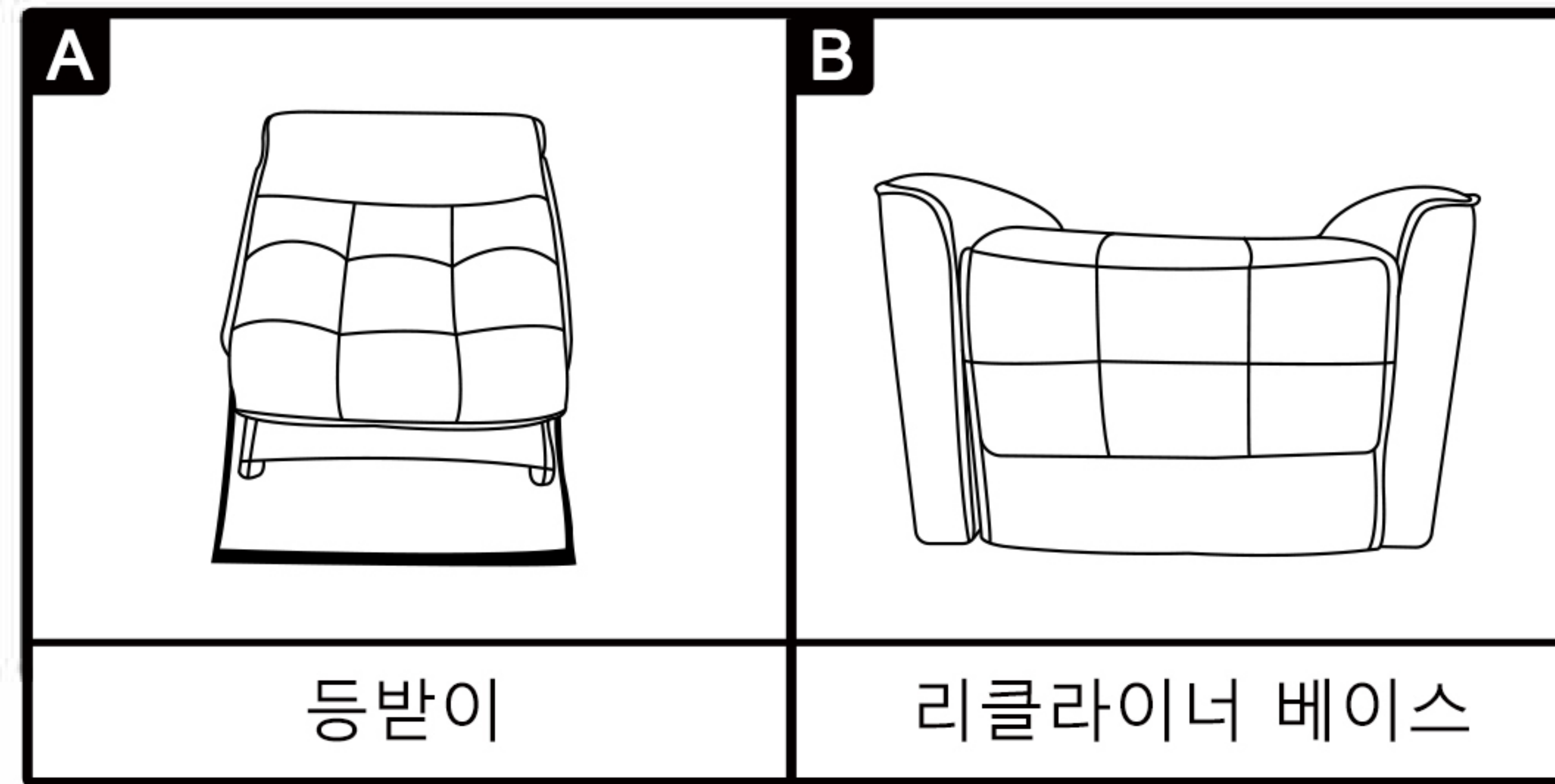

주문 번호를 애프터서비스에 보내면 다음을 받을 수 있습니다.

- ① 1년 품질 보증.
- ② ~~만족하셨든 그렇지 않으셨든~~ ~~처리가 개선하여 더 나은 경험을 제공할 수 있도록~~ 연락 주세요.

③ 제품 설치 및 사용 방법 관련 문의.  
 판매 후 우편함 [hztycservice@outlook.com](mailto:hztycservice@outlook.com)  
 판매 후 연락 번호: 855-510-1437



1단계: 리클라이너 등받이 A를 시트 베이스 B의 슬라이드에 삽입합니다. 정렬되었는지 확인하고 "딸깍" 소리가 들릴 때까지 밀어줍니다.

2단계: 휴식을 즐기세요!

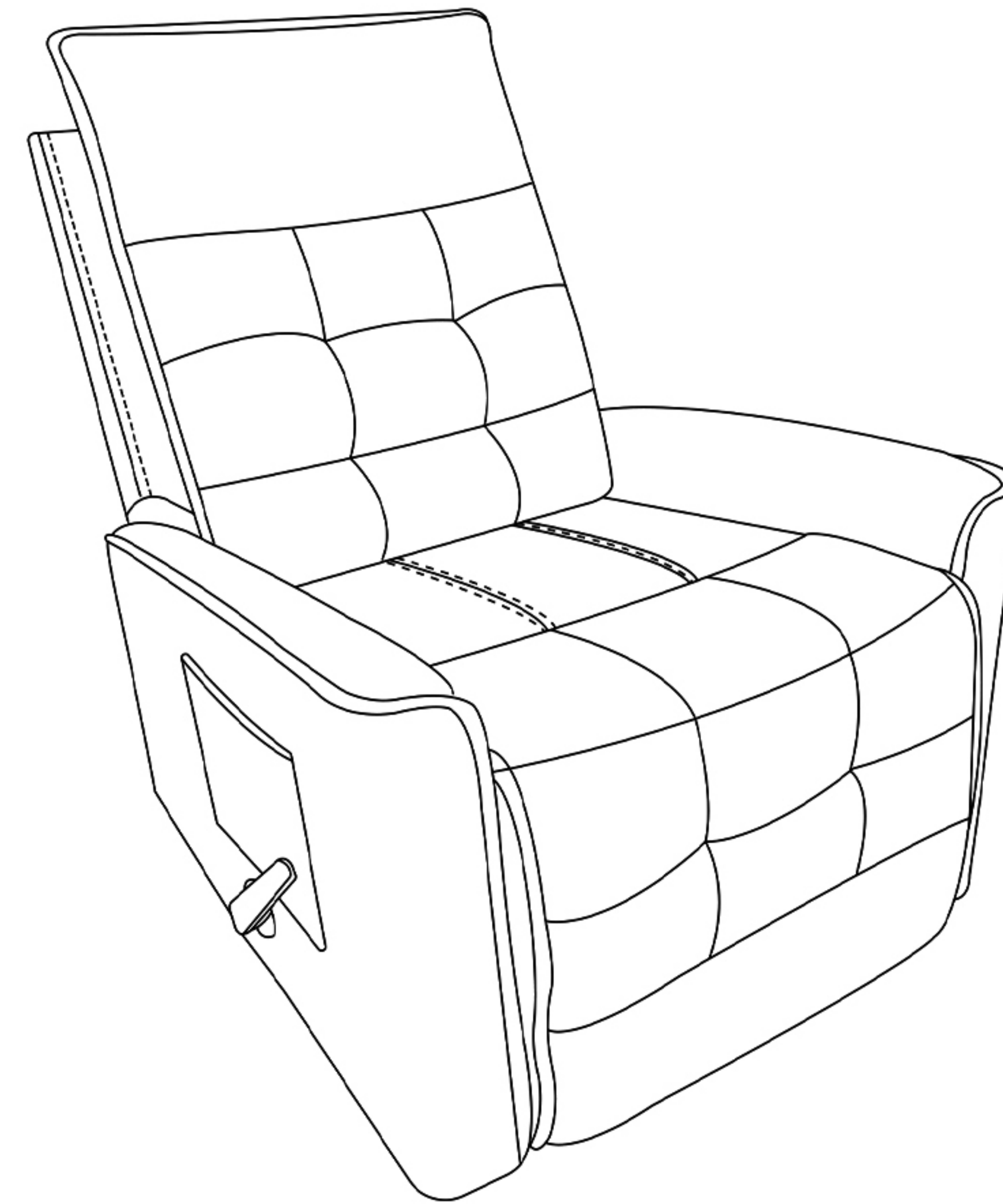
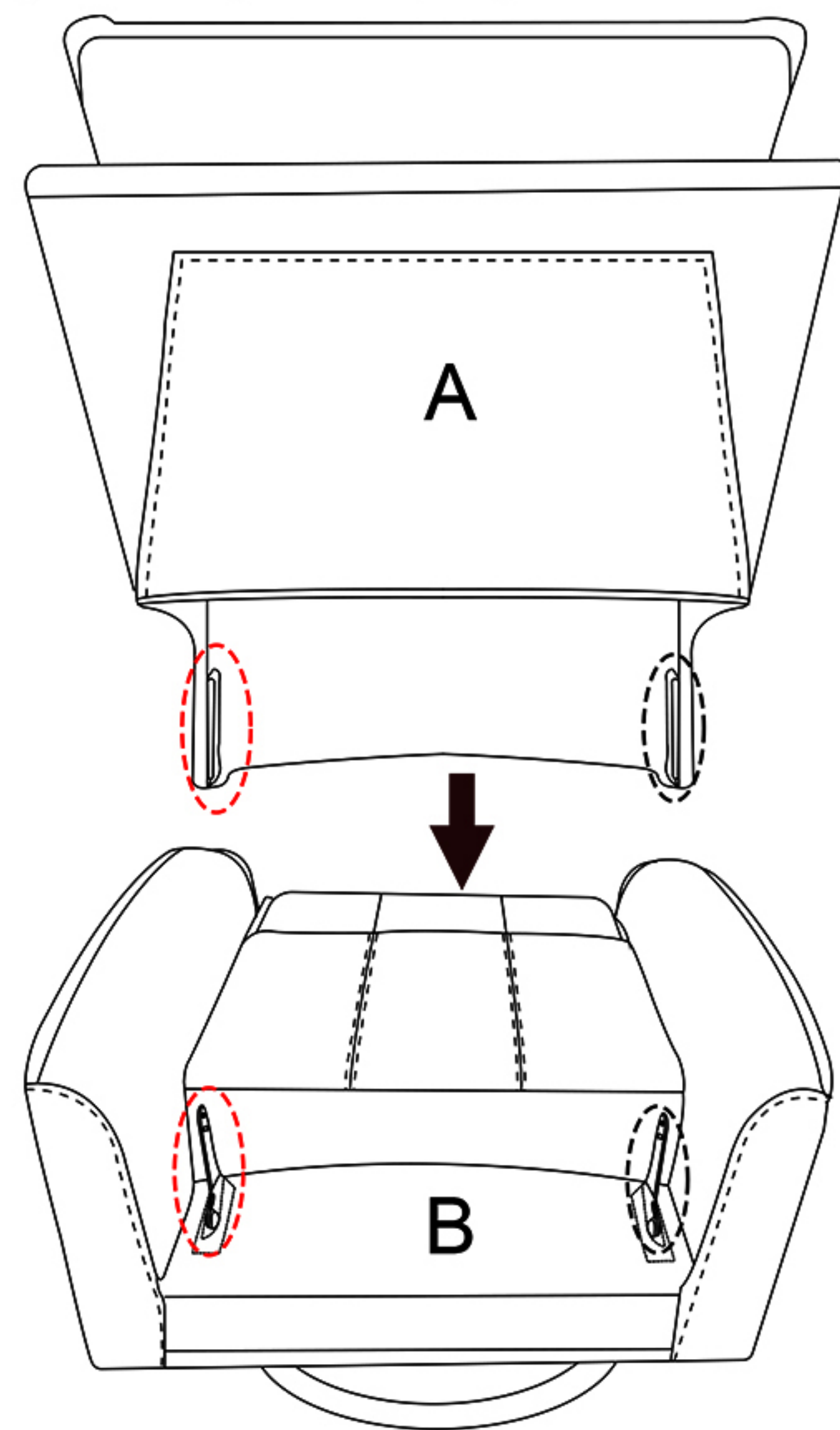

QR 코드 스캔 -  
이메일 주소

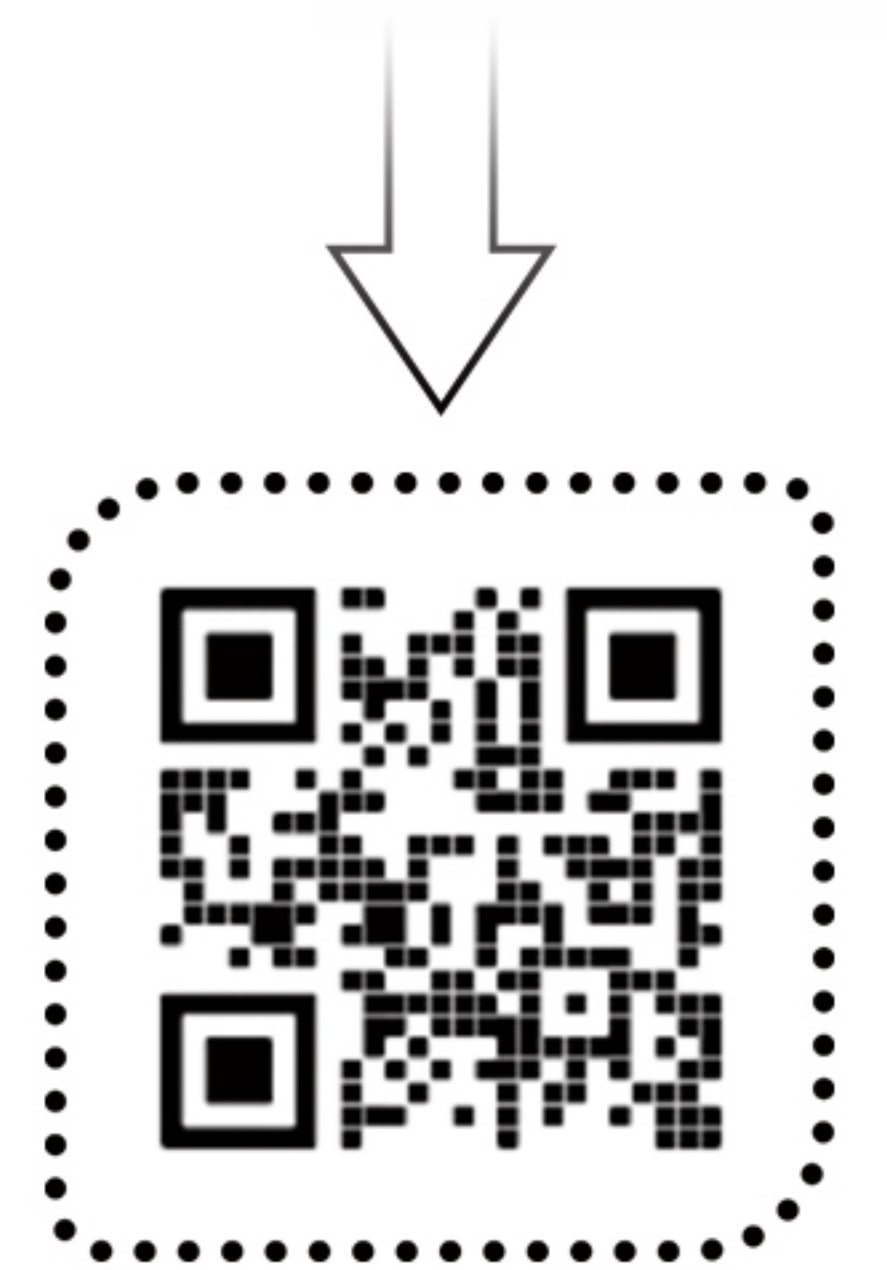

## 따뜻한 팁:

1. 처음 사용할 때 리클라이너의 발판이 부드럽게 열리고 닫히지 않는 경우 이는 정상적인 현상이며, 더 자주 사용하여 침입 기간을 거치기 만하면됩니다.
2. 무게 중심이 불안정하지 않도록 평평한 표면이나 카펫 위에서 리클라이너를 사용하세요.
3. 질문이 있으시면 애프터 서비스 팀에 연락하시면 문제를 가장 먼저 처리해 드리겠습니다!