

Assembly Instructions

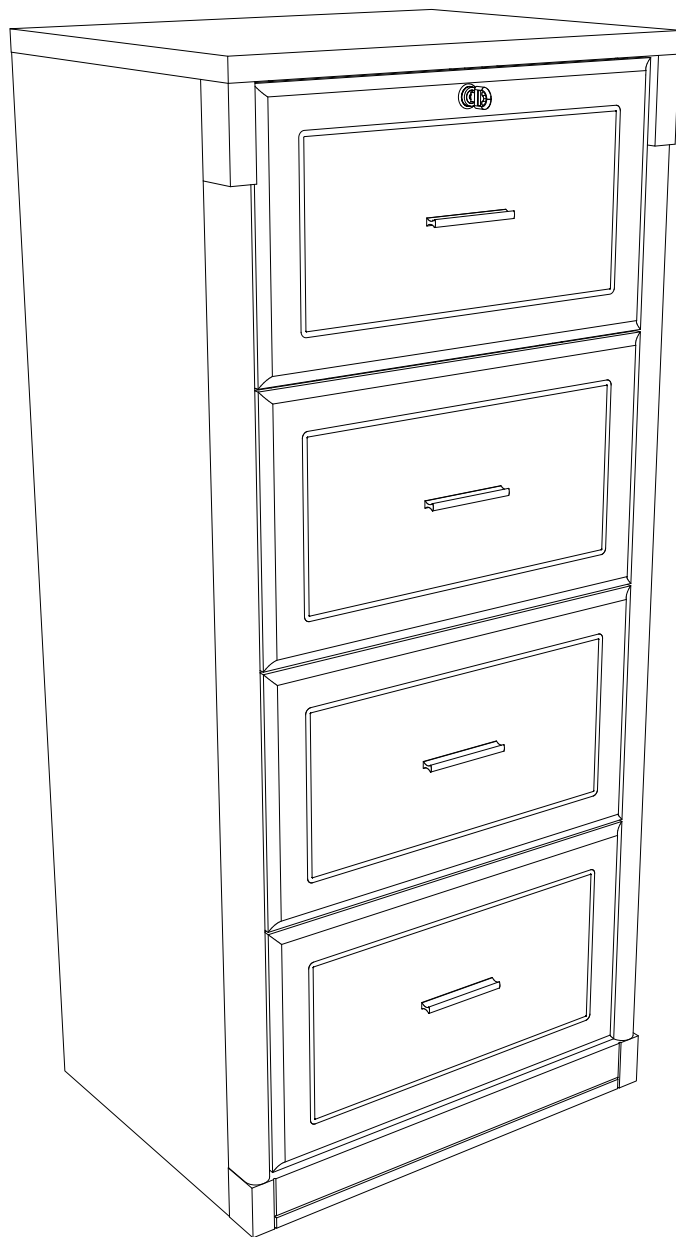

Filing Cabinet

Contact Us

We're here to help you.

Your satisfaction is our top priority. If you encounter any issues with this product, such as missing or damaged parts, we're here to help. Please retain the original packaging and take photos of the packaging and the product, then contact us as soon as possible.

Warm Tips

1. Carefully read these instructions and keep them for future reference.
2. Check the parts list and confirm everything's there before starting assembly.
3. When assembling, put all parts on a soft, smooth surface like a carpet to avoid scratches.
4. Don't fully tighten screws until all parts are confirmed in place to avoid misalignment.

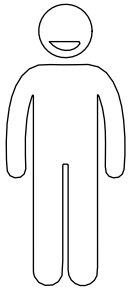

X2

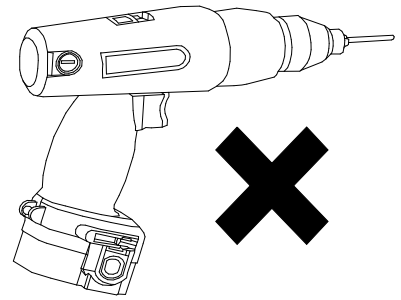
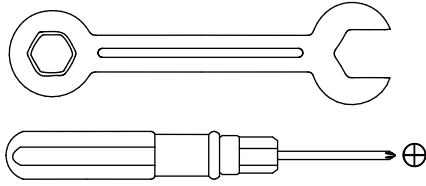

We recommend using hand tools for assembly.

If an electric screwdriver is used, reduce power and torque to avoid damage to the product.

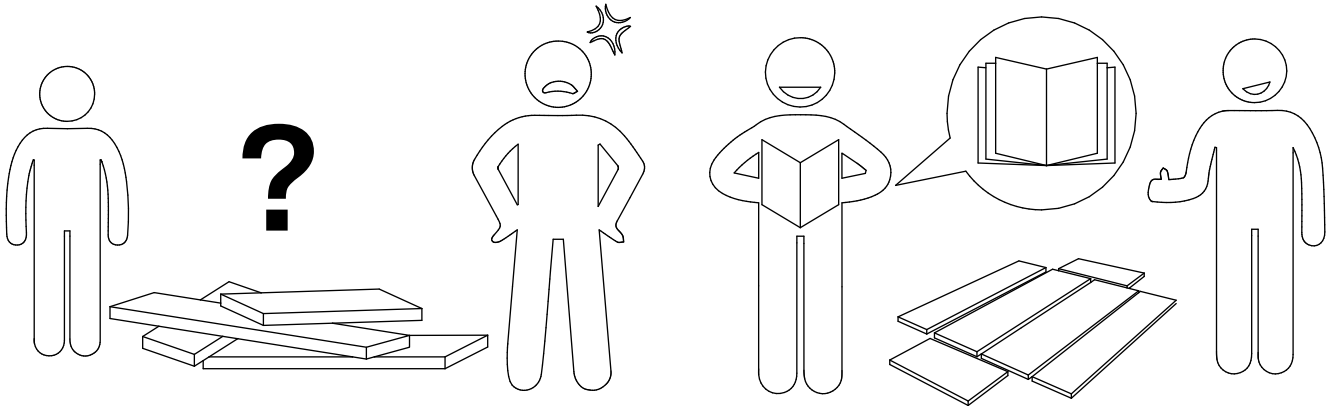

AVOID SCRATCHES

In order to avoid scratching, this furniture should be assembled on a soft surface, such as a rug.

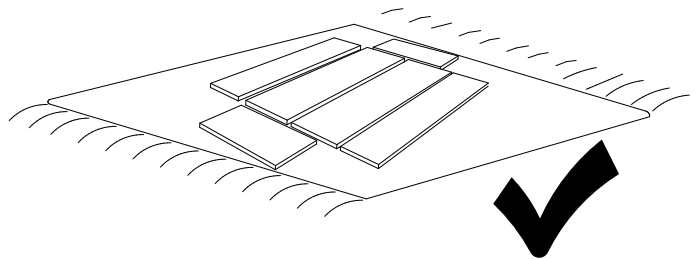
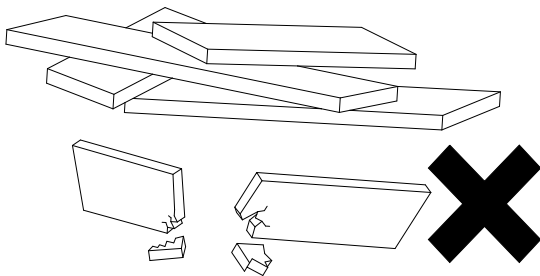

Install the Anti-Tip Straps

Using the anti-tip straps can reduce the risk of tipping over, but can not eliminate it.

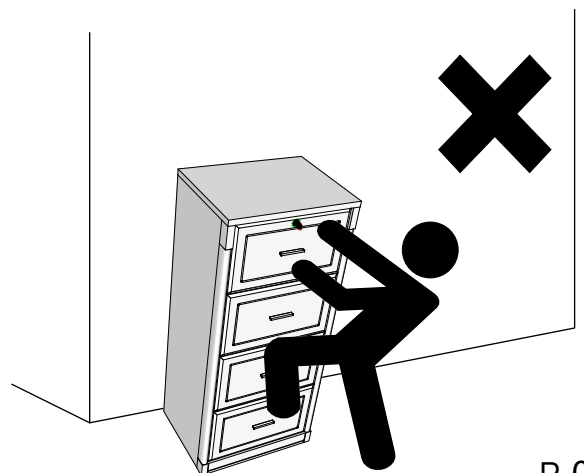
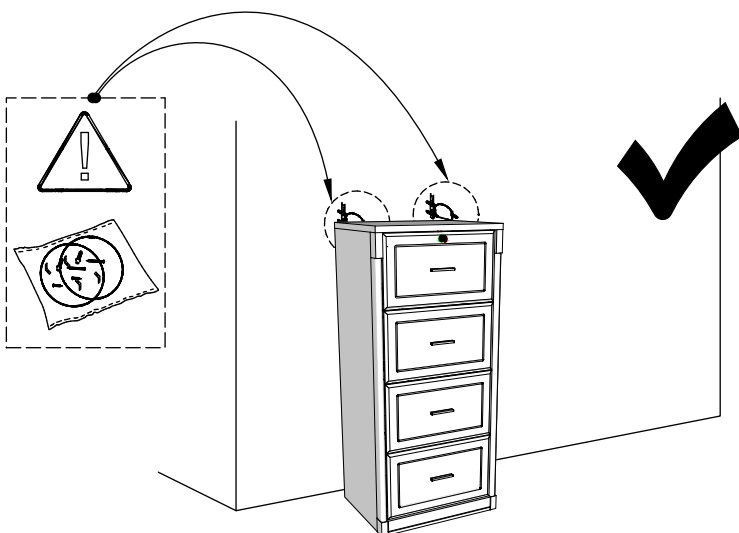

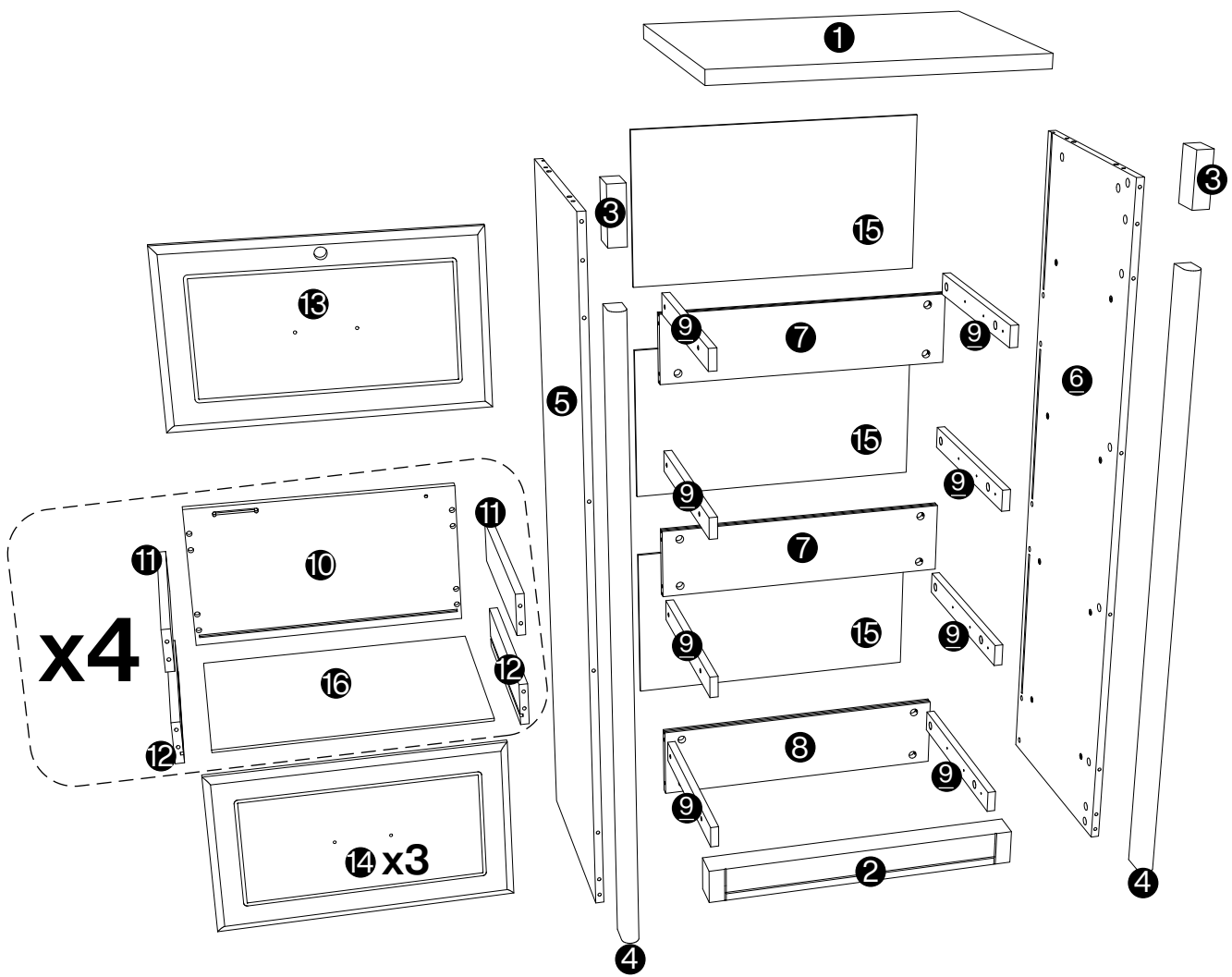







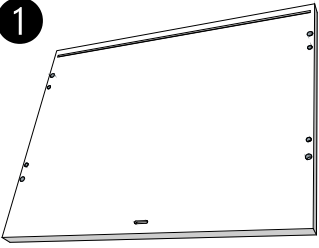
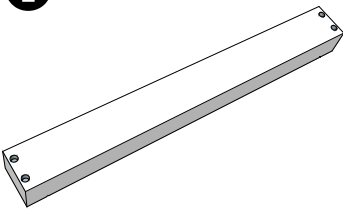
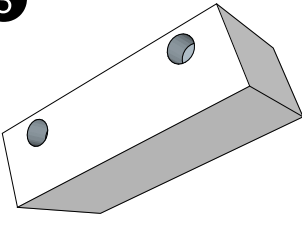
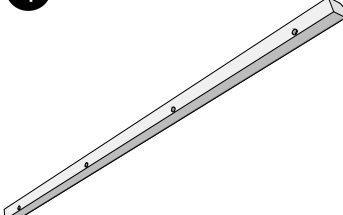
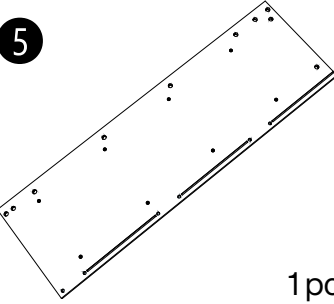
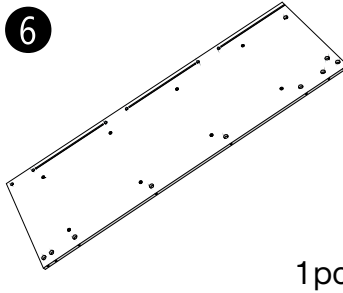
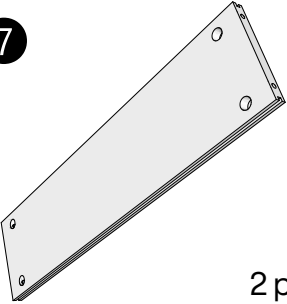
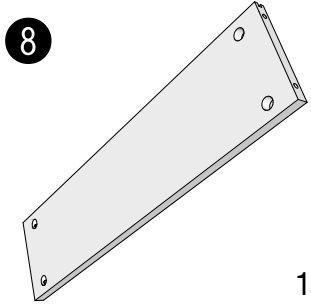
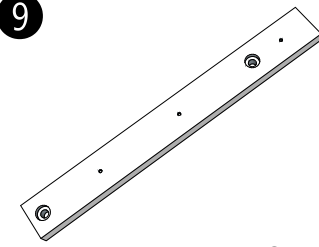
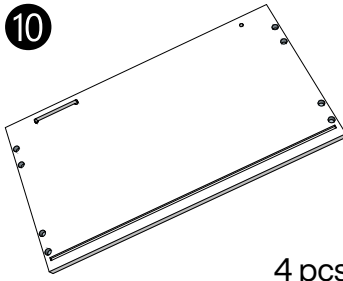
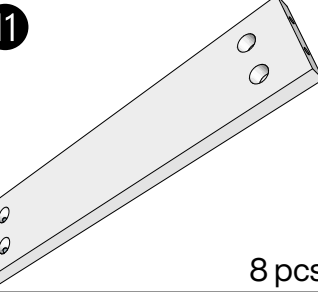
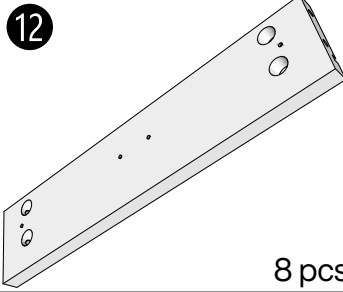
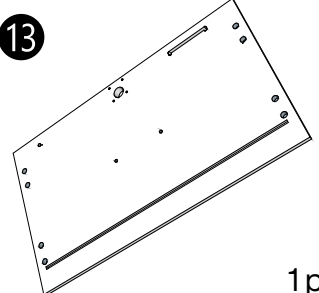
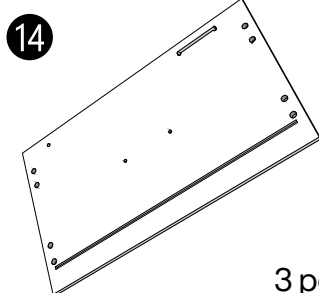
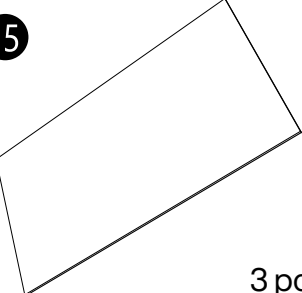
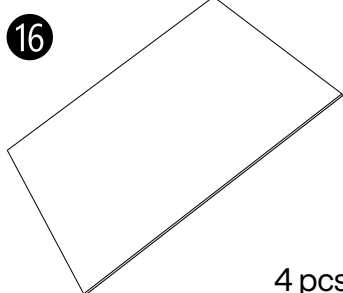

⚠ Caution

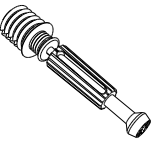
Make sure all parts are included. Most board parts are labeled or stamped on the raw edge. Contact us for a free replacement if you encounter any damaged or missing parts.

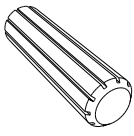
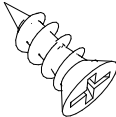
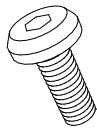
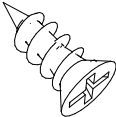
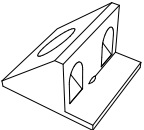
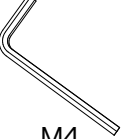
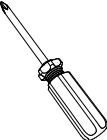
Parts List

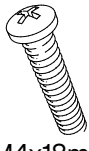
 1 pc	 1 pc	 2 pcs	 2 pcs
 1 pc	 1 pc	 2 pcs	 1 pc
 8 pcs	 4 pcs	 8 pcs	 8 pcs
 1 pc	 3 pcs	 3 pcs	 4 pcs

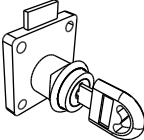
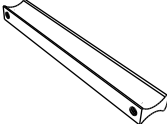
Hardware List

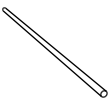
A	B	C	D	E	F	G	H
 M6x40mm	 Ø15x12mm	 Ø8x30mm	 Ø3.5x14mm	 M6x20mm	 Ø3x18mm		 M4
97 pcs	97 pcs	5 pcs	49 pcs	17 pcs	23 pcs	19 pcs	1 pc
I	J	K	L	M	N	O	P
		 M4x18mm					
1 pc	5 pcs	9 pcs	1 pc	1 pc	4 pcs	8 pcs	8 pcs

Installation of Cams and Pins

Step 1-2: Align the plastic part with the mounting hole and press it in. If you can't press it in, loosen the screw counter clockwise or completely remove the screw from the plastic part and try again.
Step 3-4: After pressing the plastic part into place, use a screwdriver to tighten the screw clockwise.

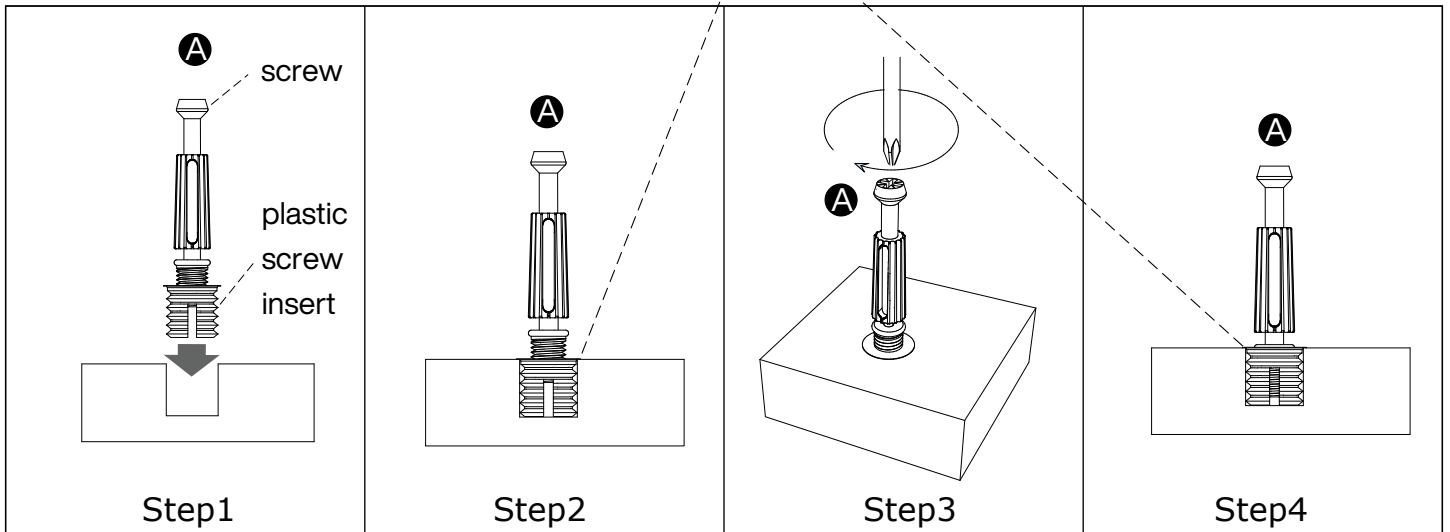
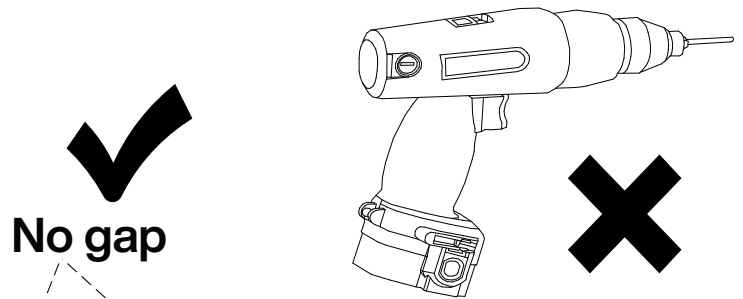

Screw the pin into the hole. Set the cams correctly by aligning the head of the cams with the lock pins. Lock the cam by turning the cam head with a screwdriver until it is tightened. Please do not use an electric screwdriver to assemble the unit.

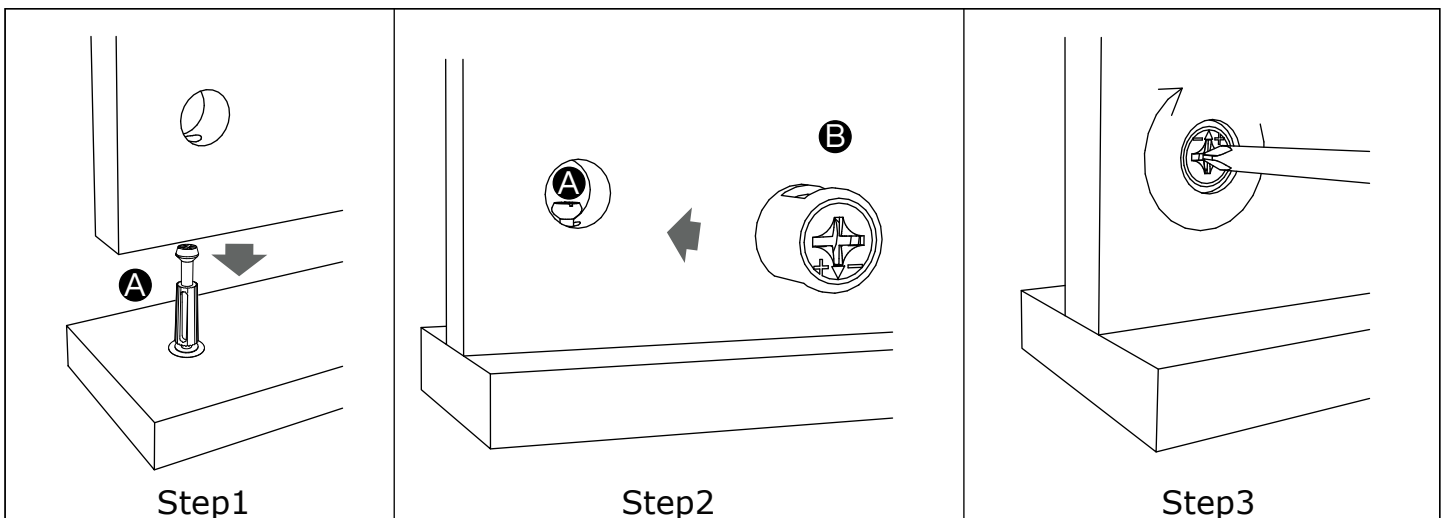

1

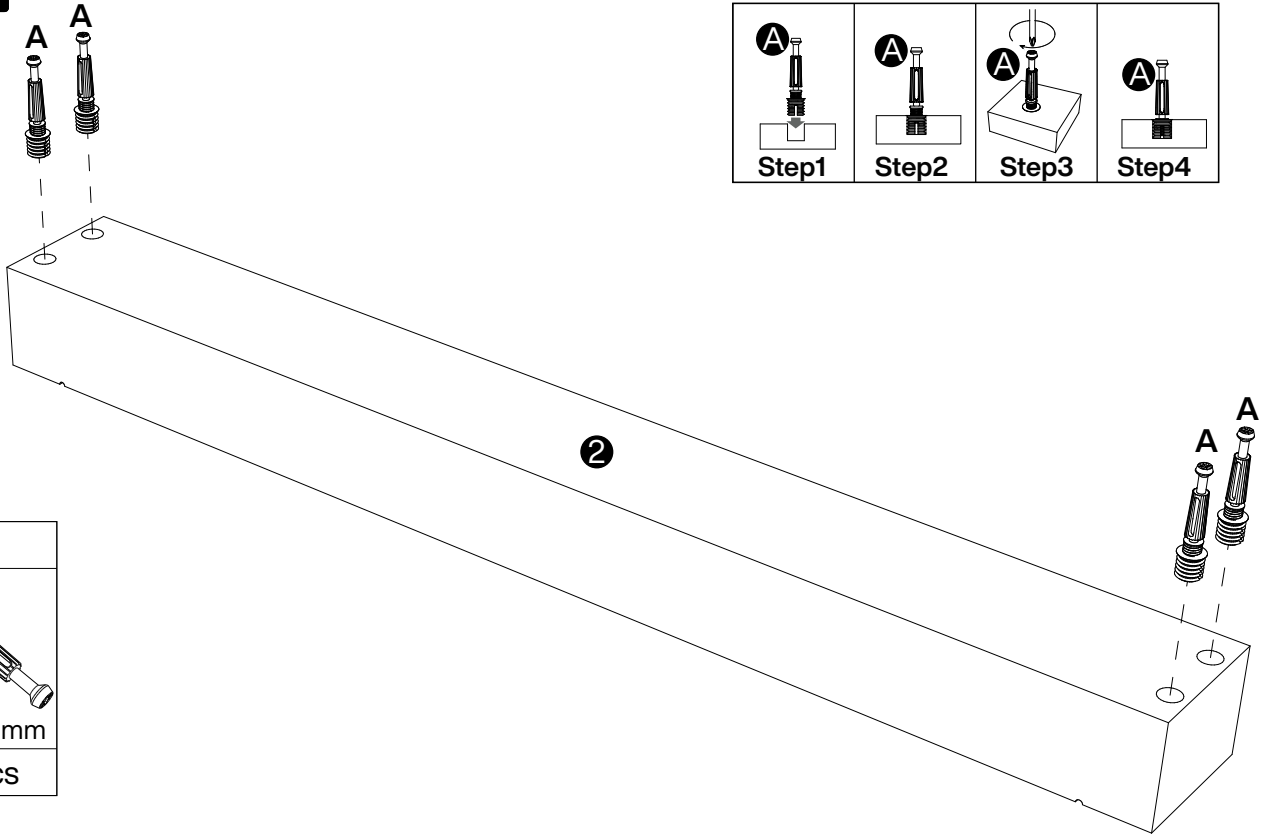

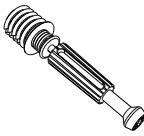
A

M6x40mm
4 pcs

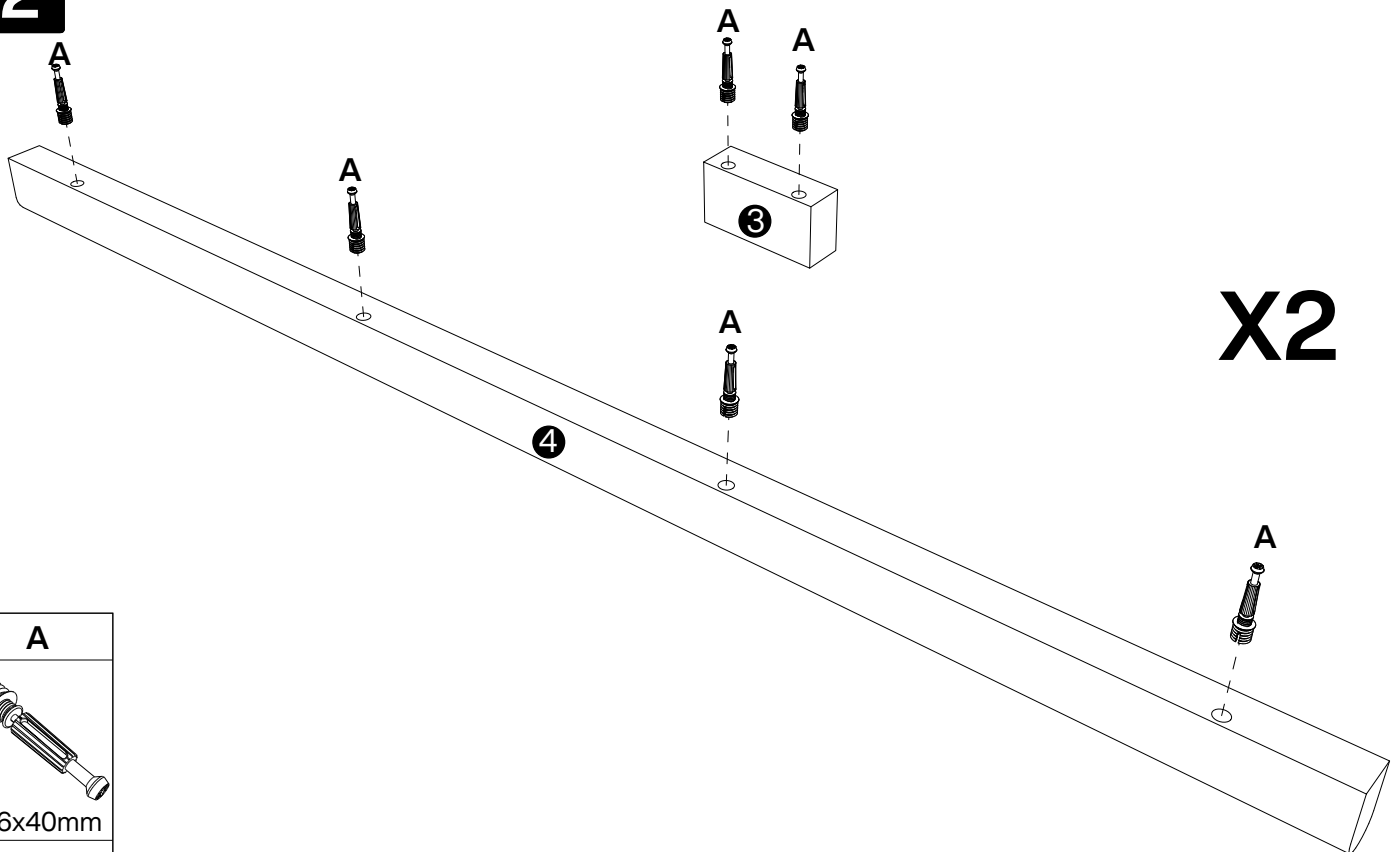
2

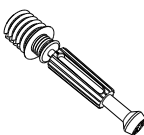

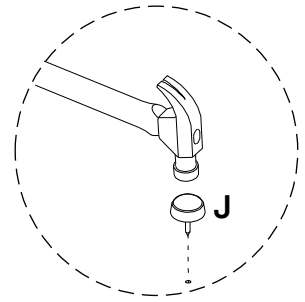
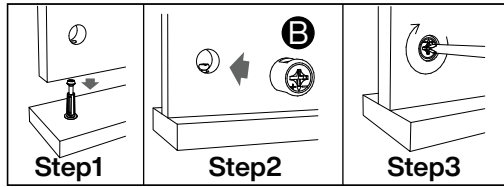

A

M6x40mm
12 pcs

3

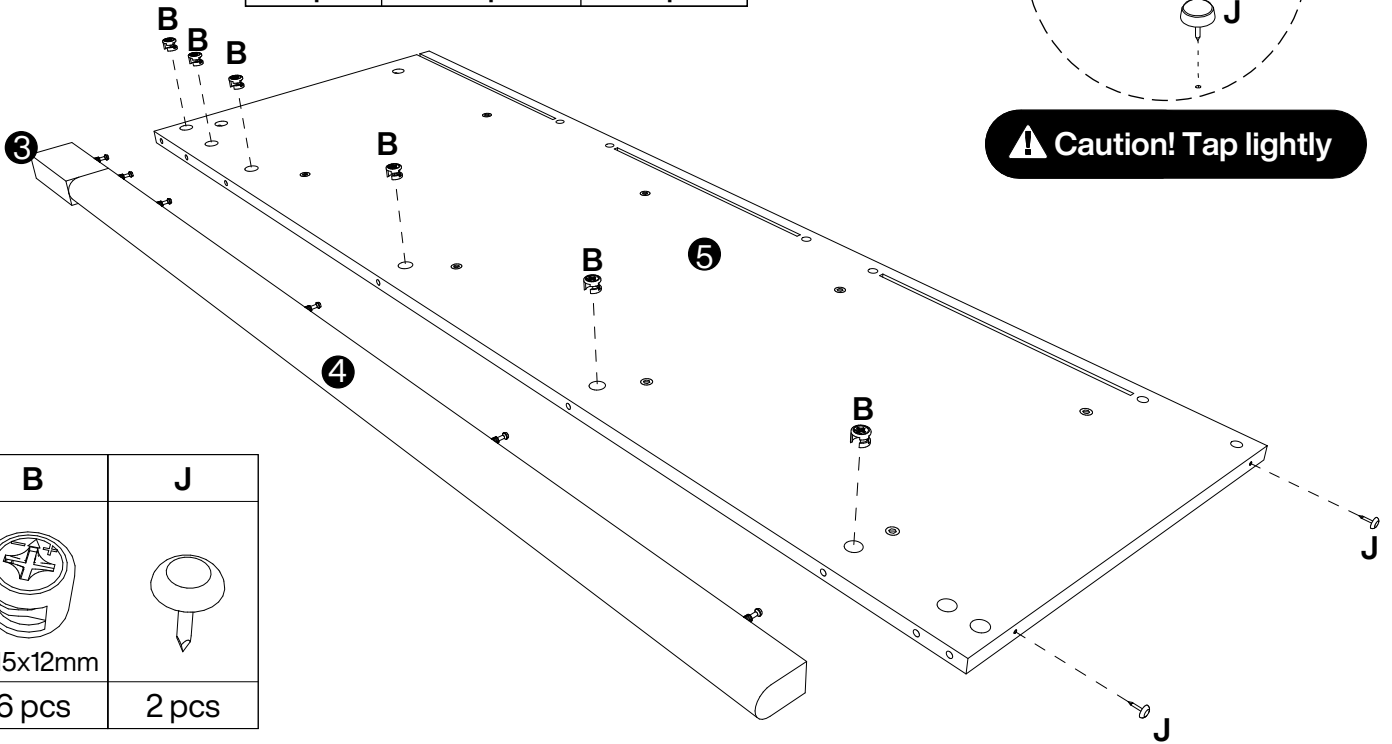



⚠ Caution! Tap lightly

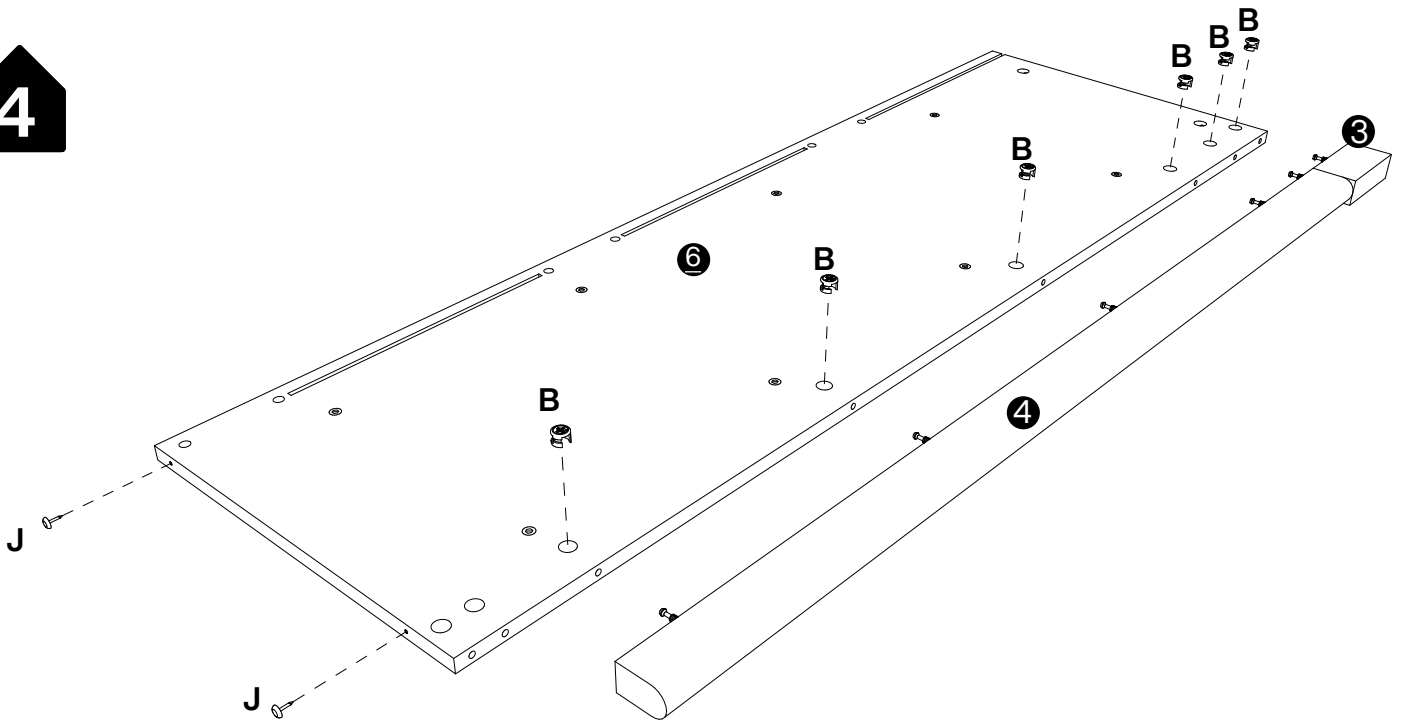

B	J
	
Ø15x12mm	
6 pcs	2 pcs

4

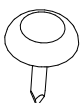

B	J
	
Ø15x12mm	
6 pcs	2 pcs

5

Reverse side,
Pay attention
to the hole
position

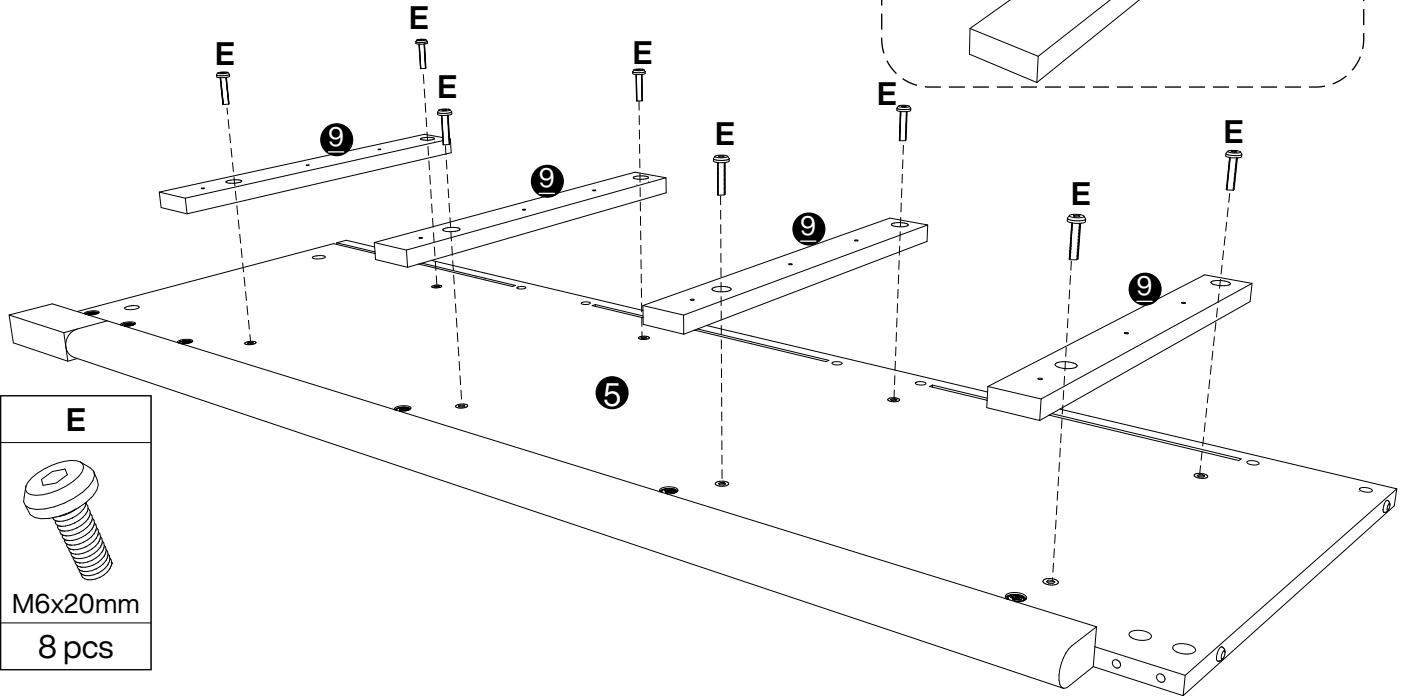
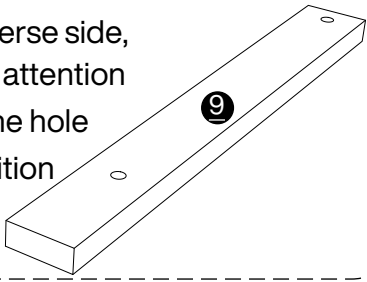

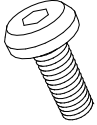
E

M6x20mm
8 pcs

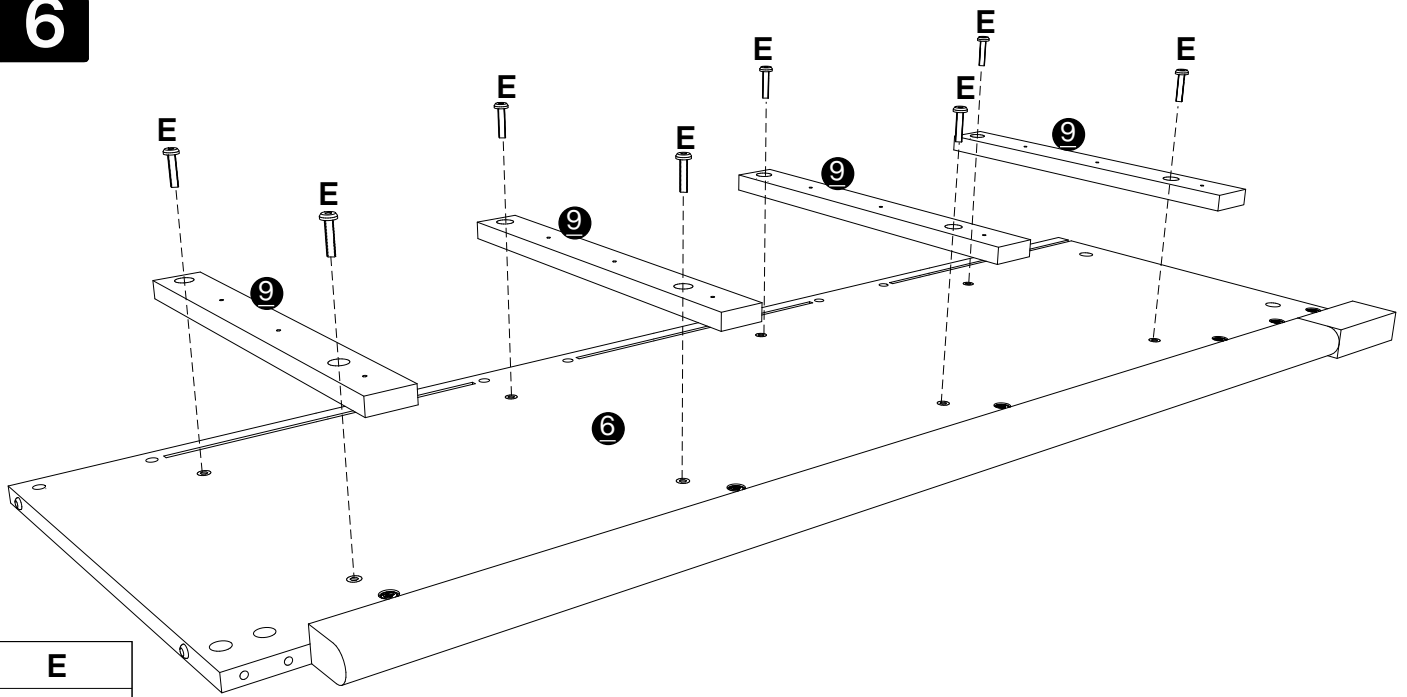
6

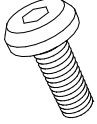

E

M6x20mm
8 pcs

7

Please split component "O" into "O-1" and "O-2" before assembling the slide and then proceed to the next step of assembly

Step 1

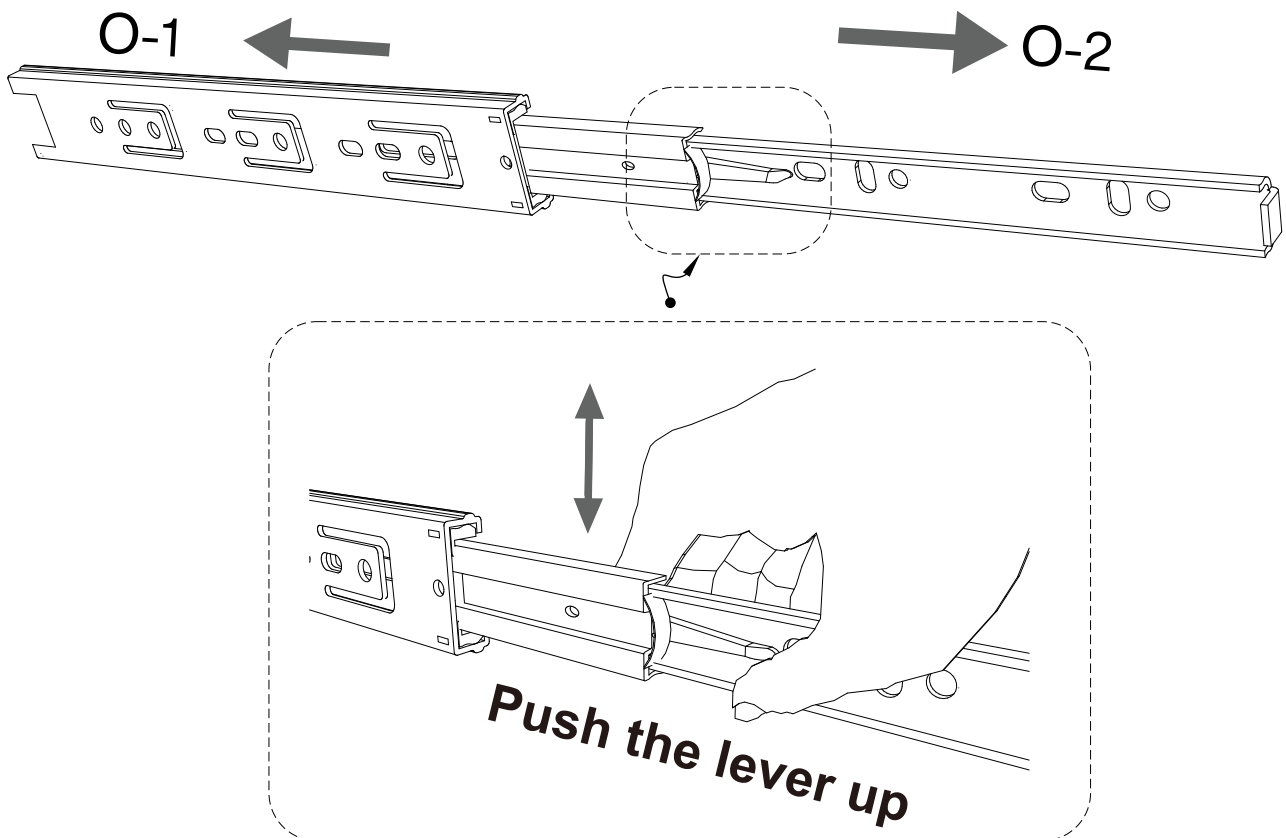
Pull apart component "O" to each side, and then gently push up the lever of component "O-2"



Step 2

Split component "O-1" and "O-2"

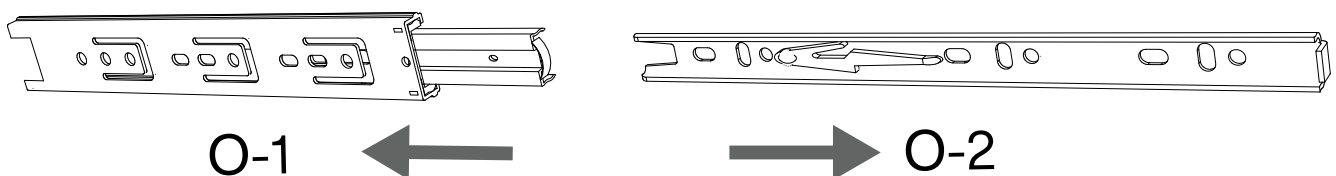

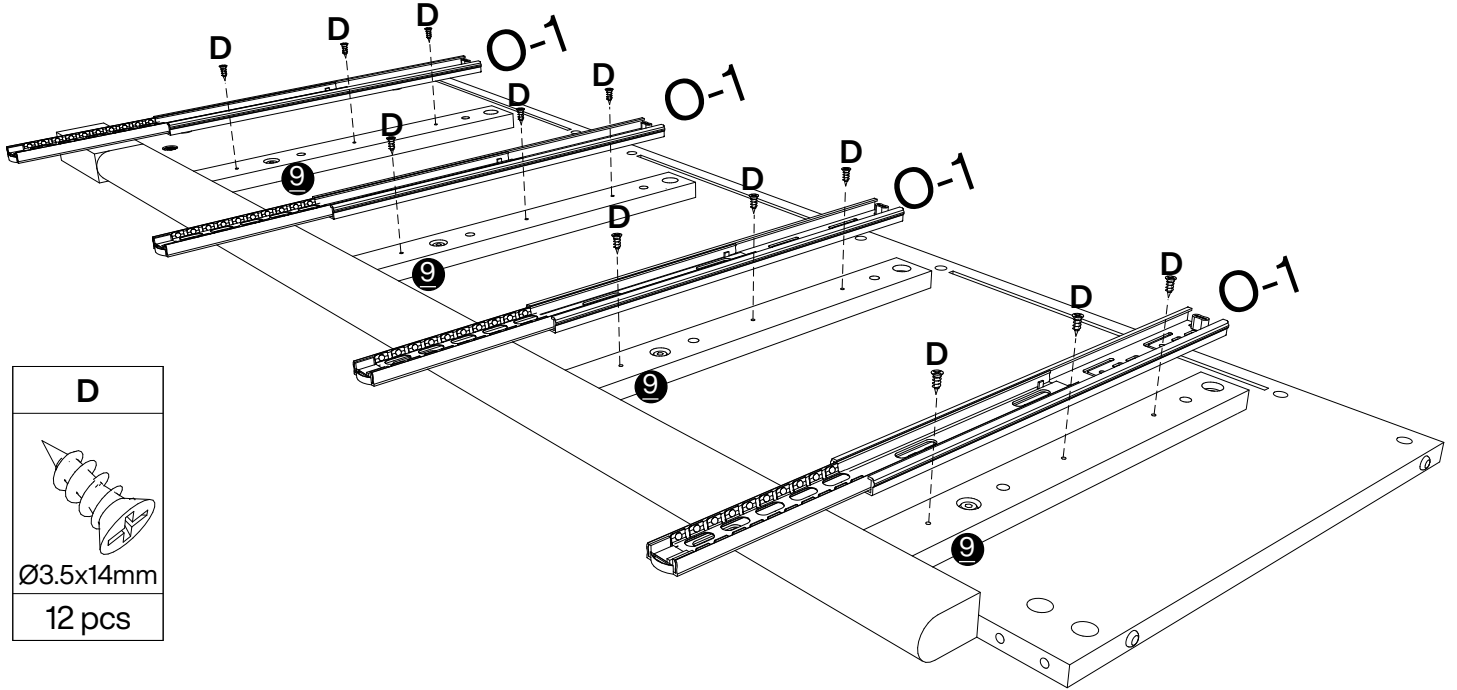
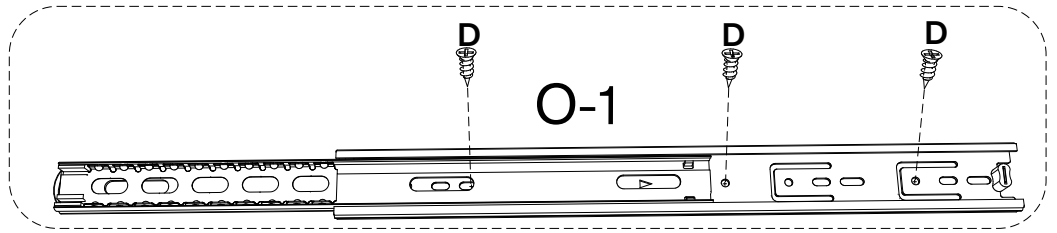

8

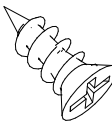

D

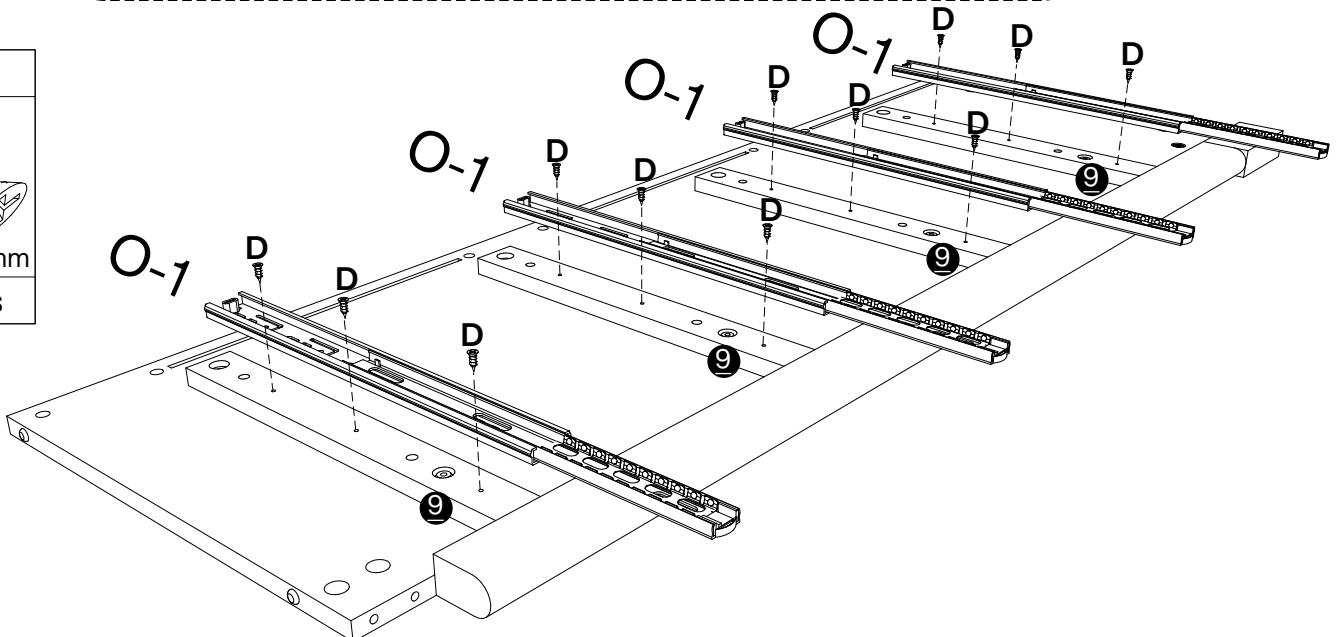
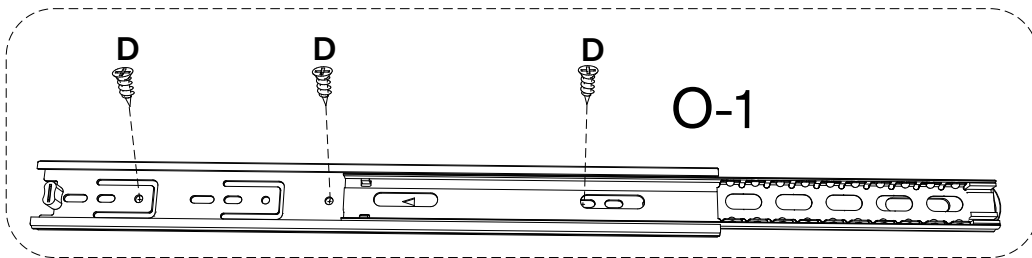
Ø3.5x14mm
12 pcs

9

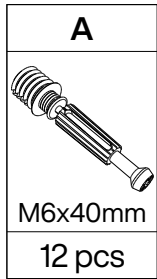
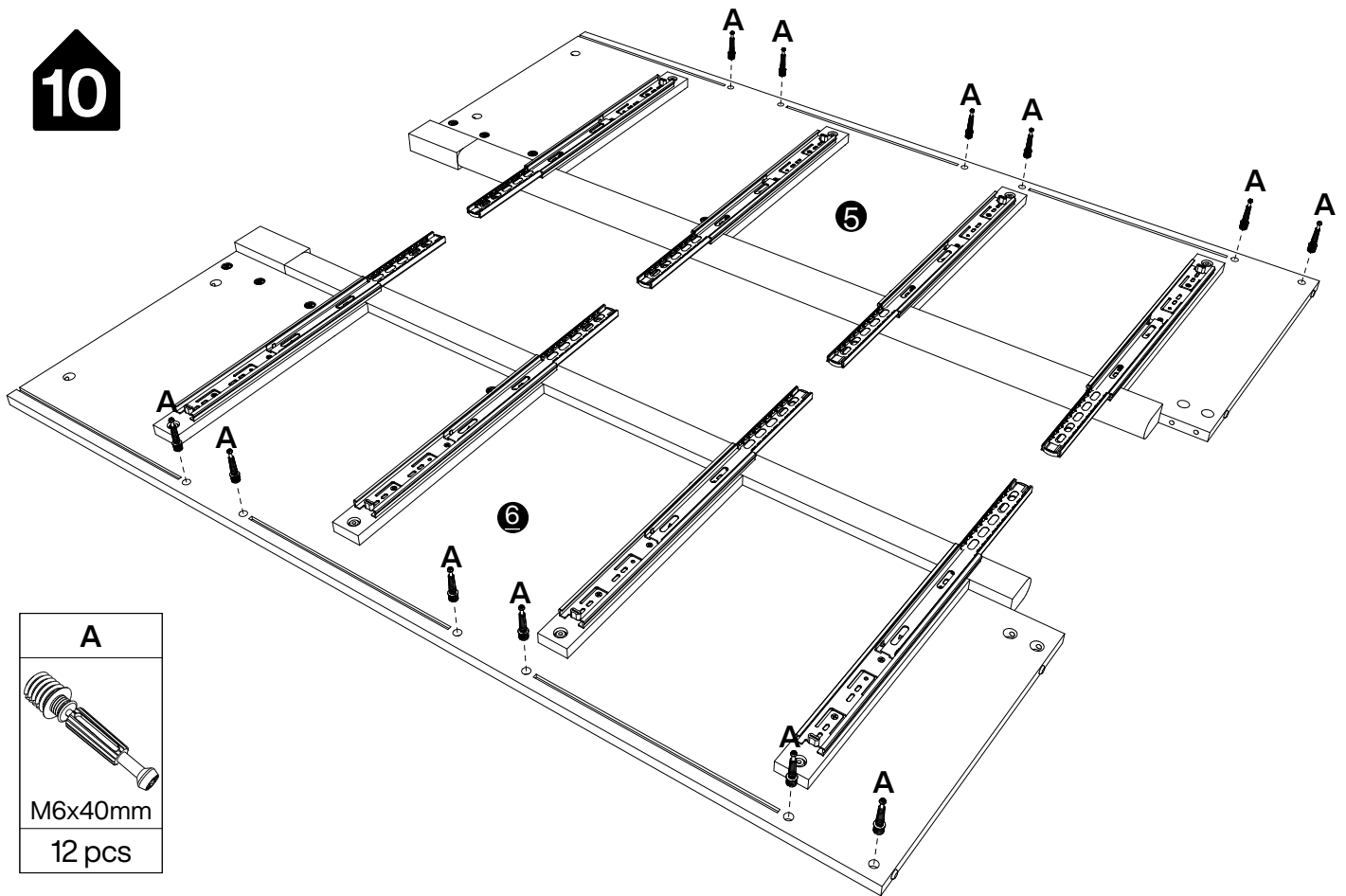

D

Ø3.5x14mm
12 pcs

10

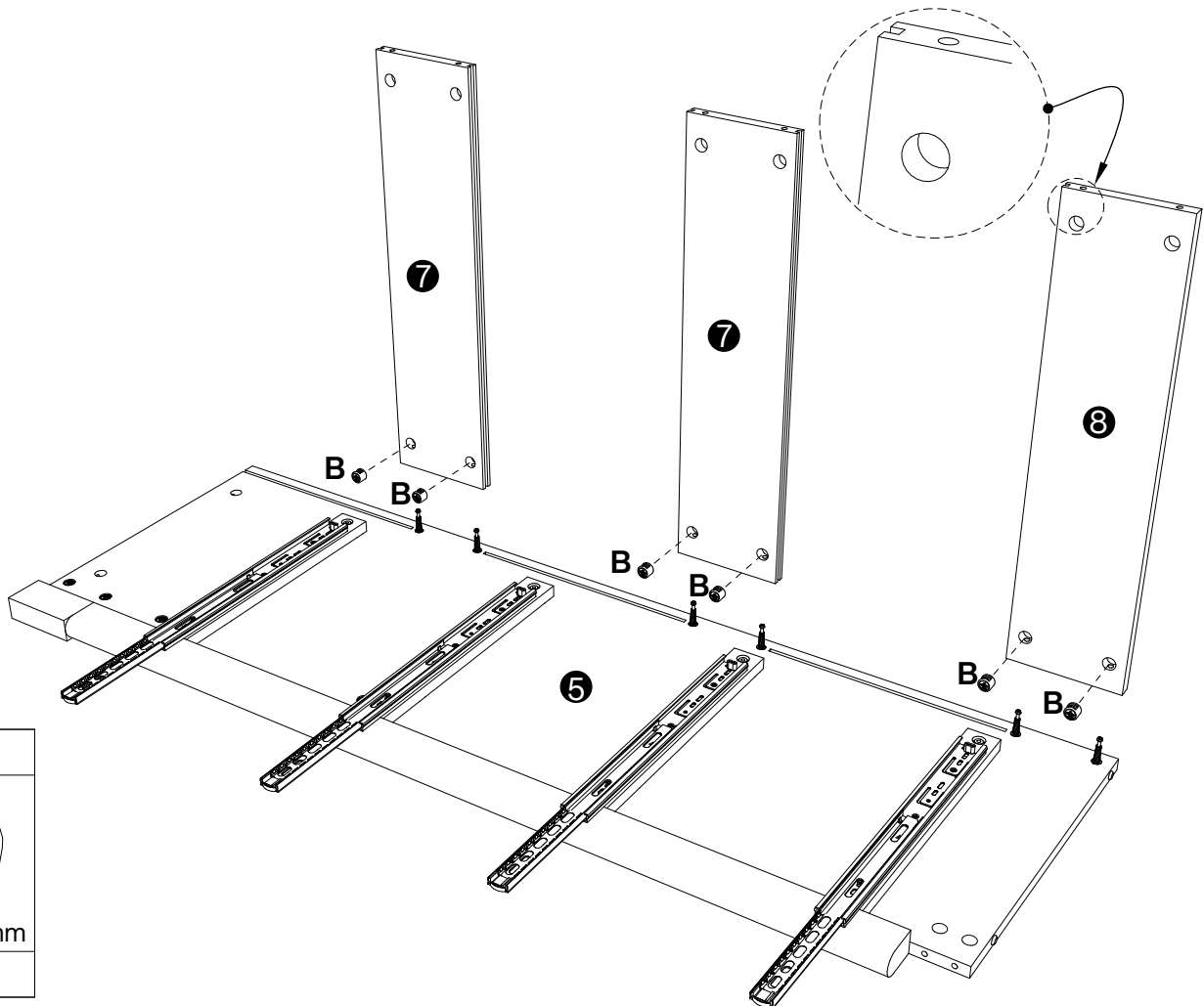

11



12

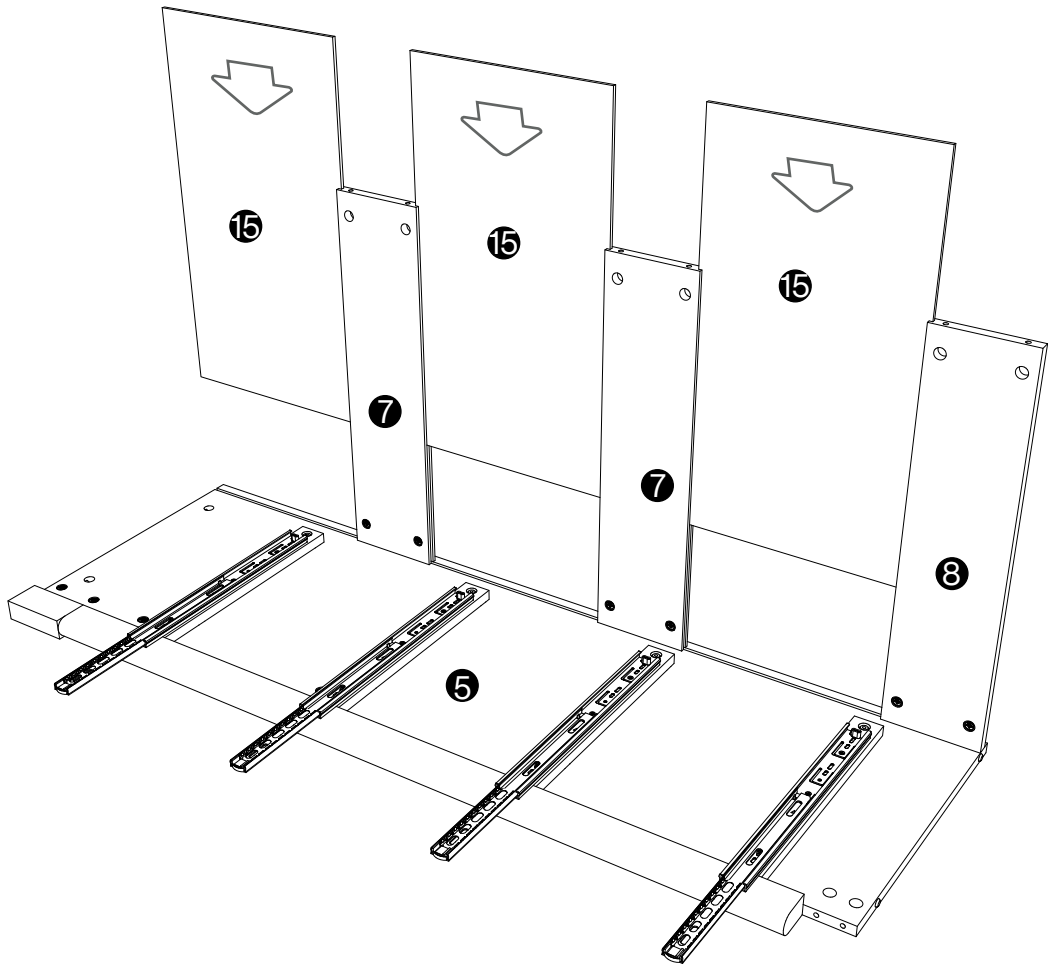

13

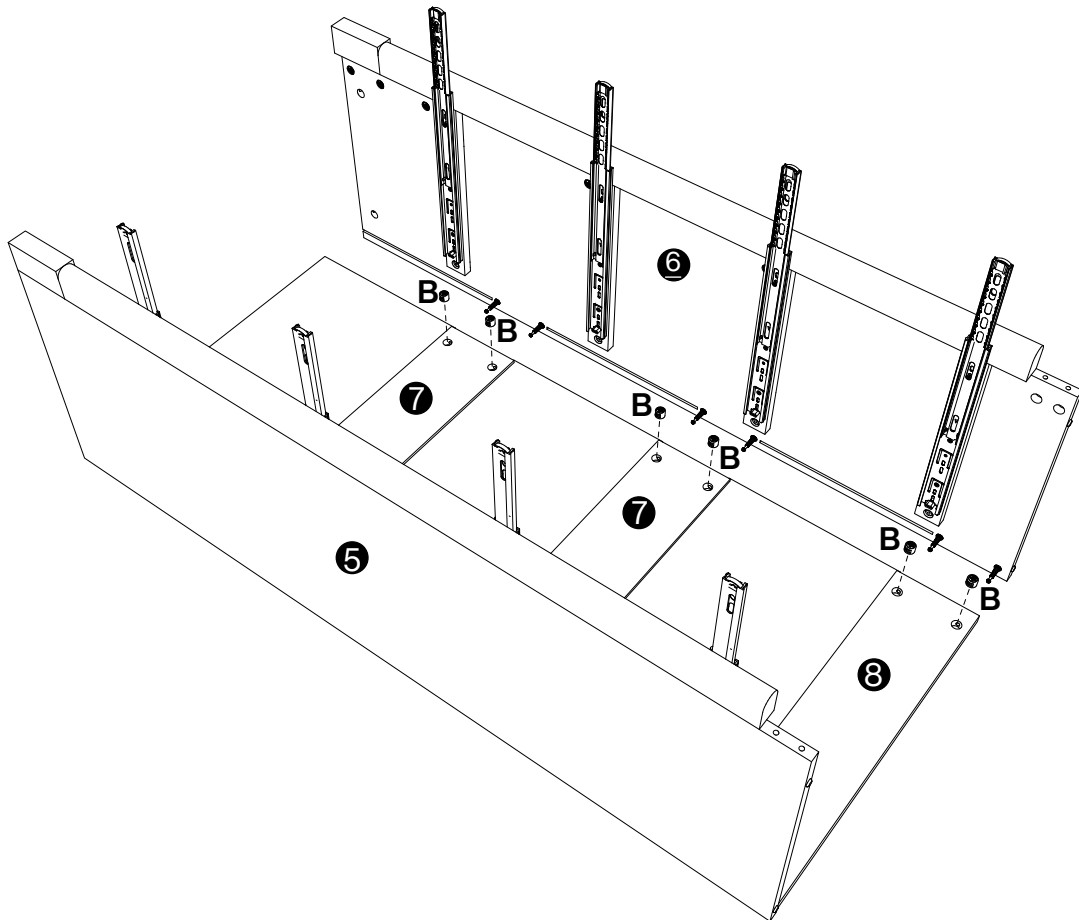

14

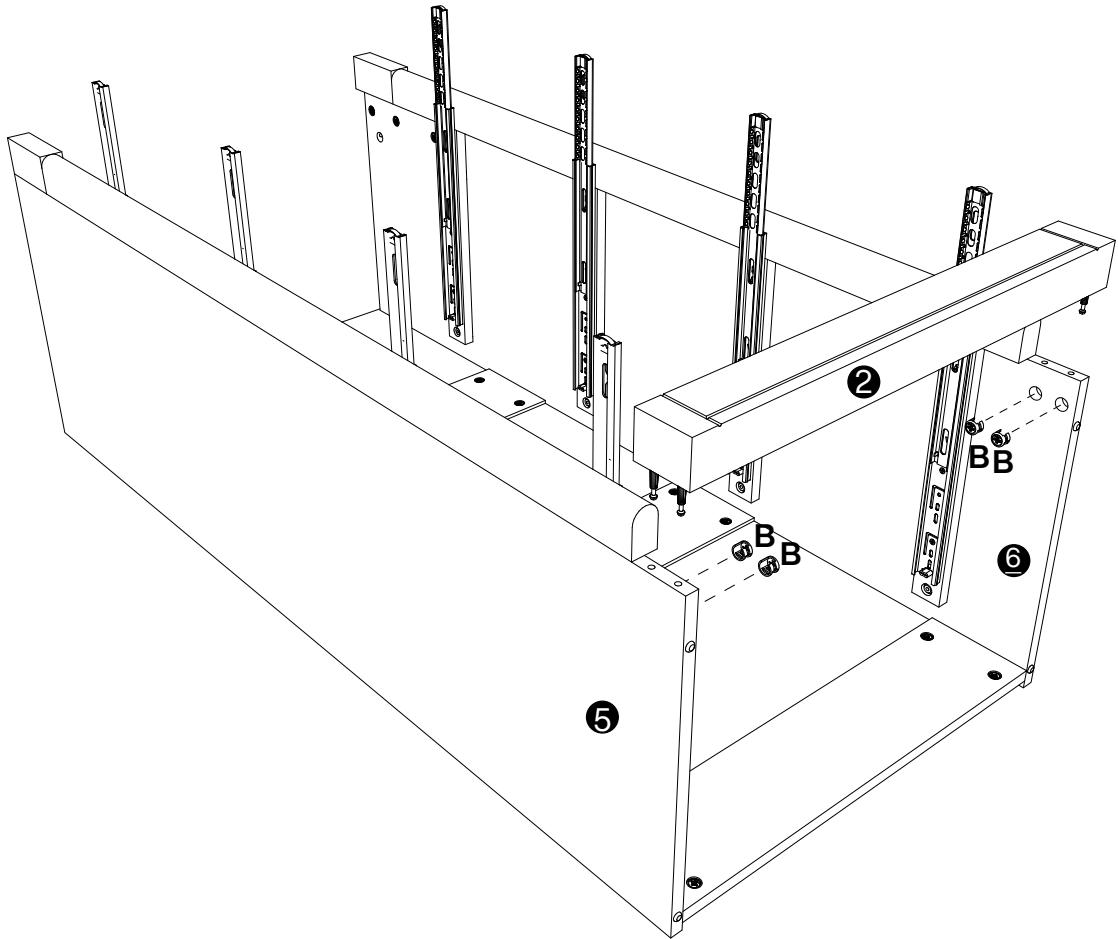

B

Ø15x12mm
4 pcs

15

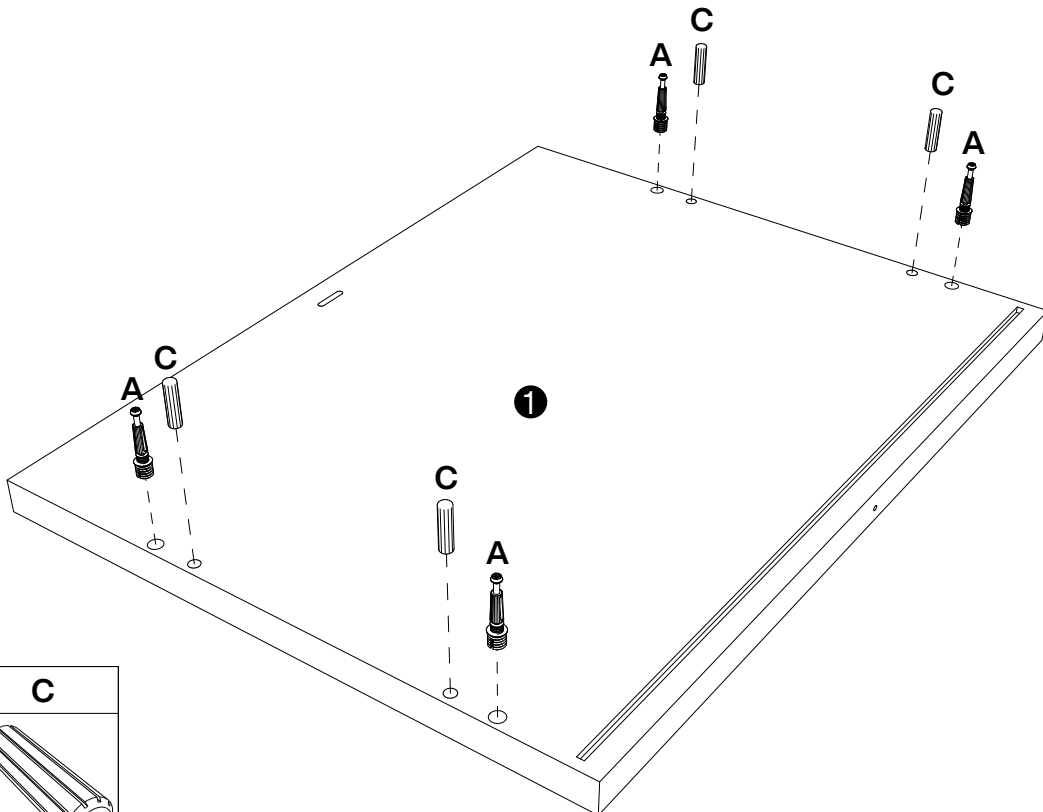

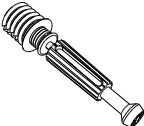
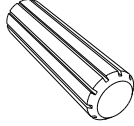
A	C
	
M6x40mm	Ø8x30mm
4 pcs	4 pcs

16

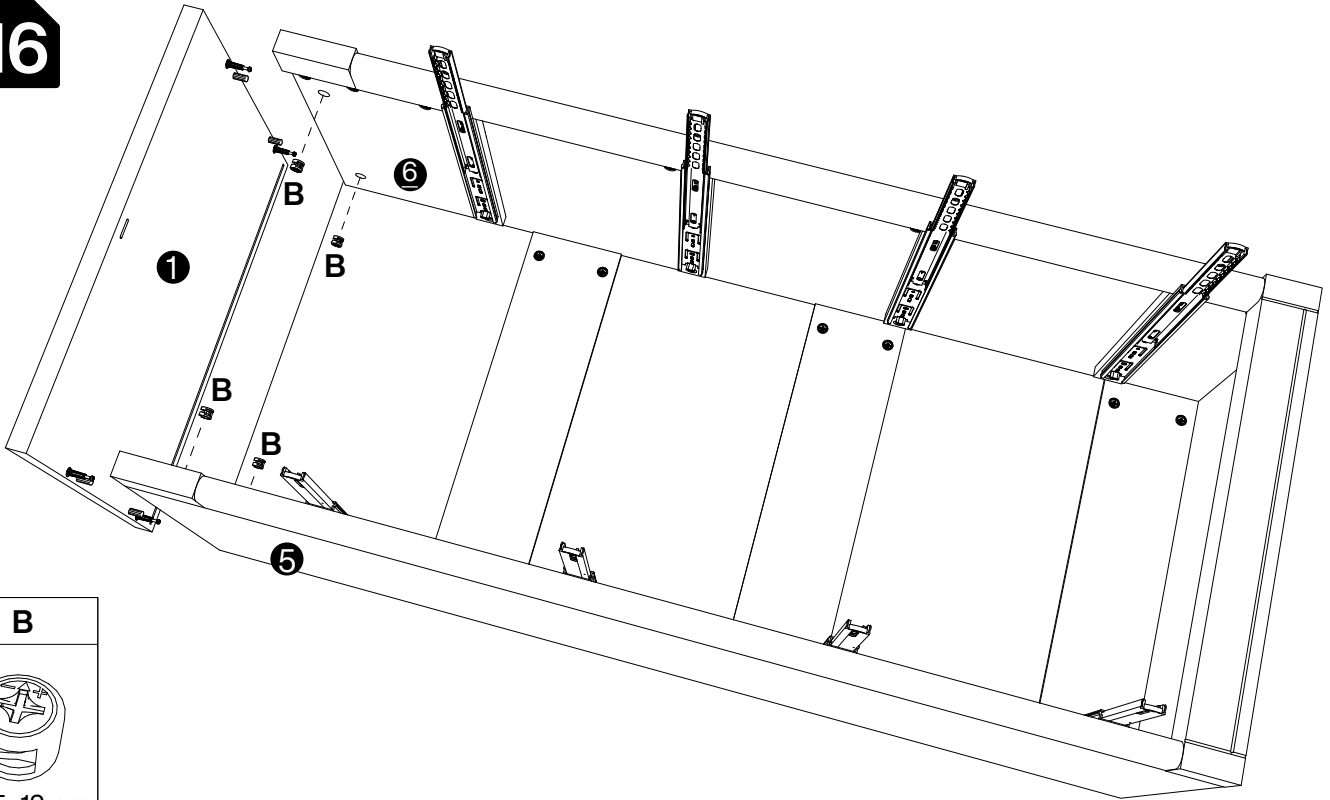

B

Ø15x12mm
4 pcs

17

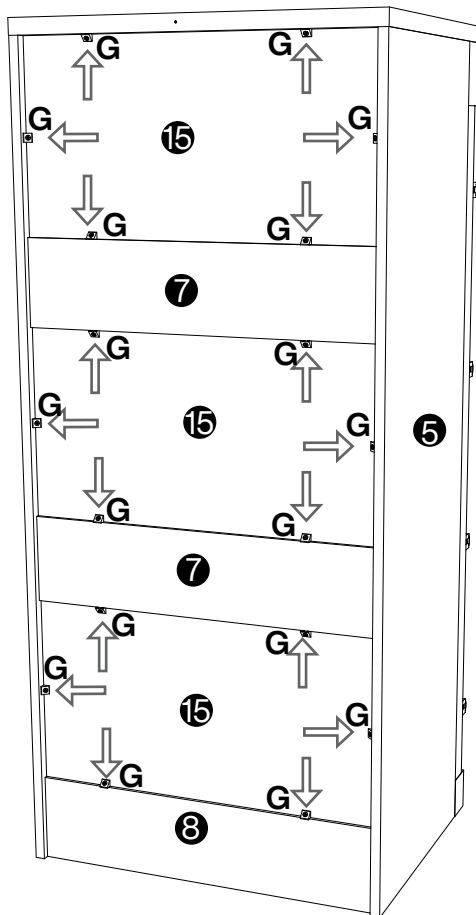



F

Ø3x18mm
18 pcs
G

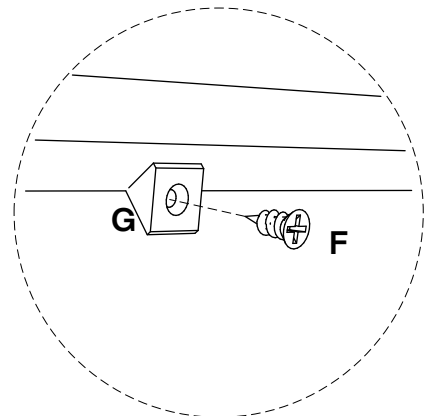
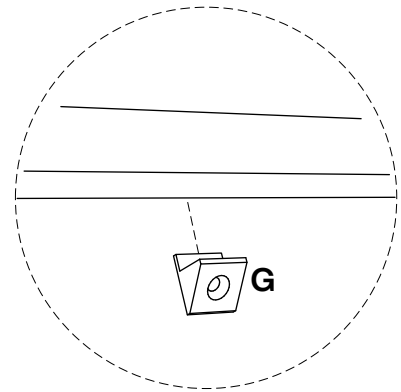
18 pcs



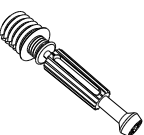
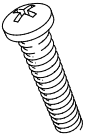

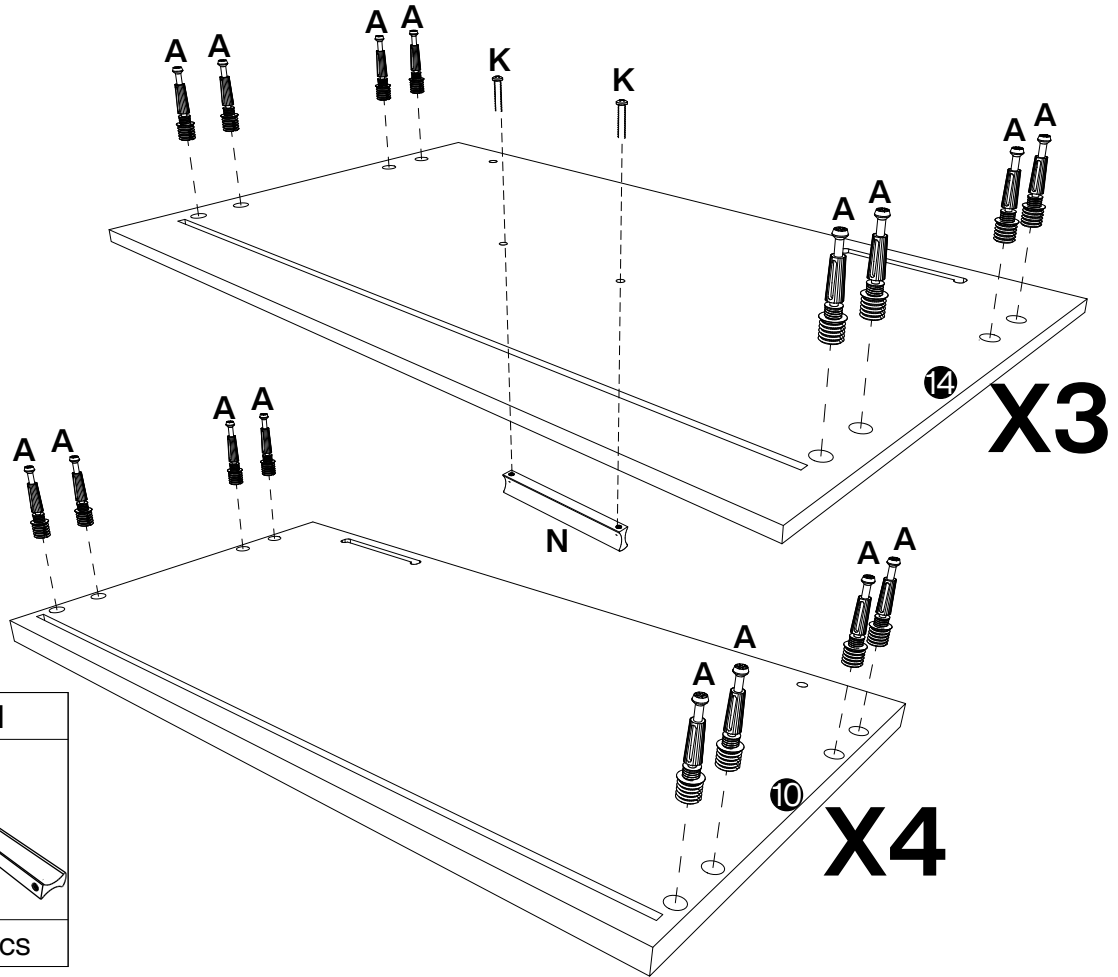

18

A	
	
M6x40mm	
56 pcs	
K	N
	
M4x18mm	
6 pcs	3 pcs

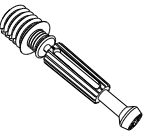

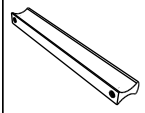
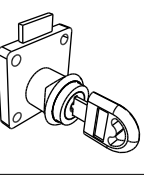

19

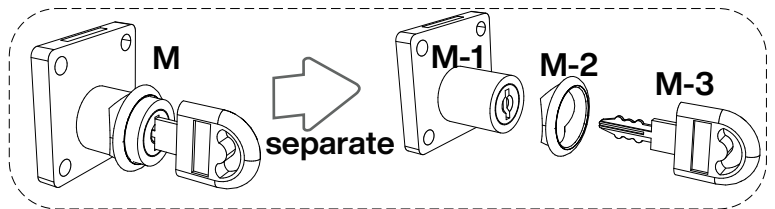
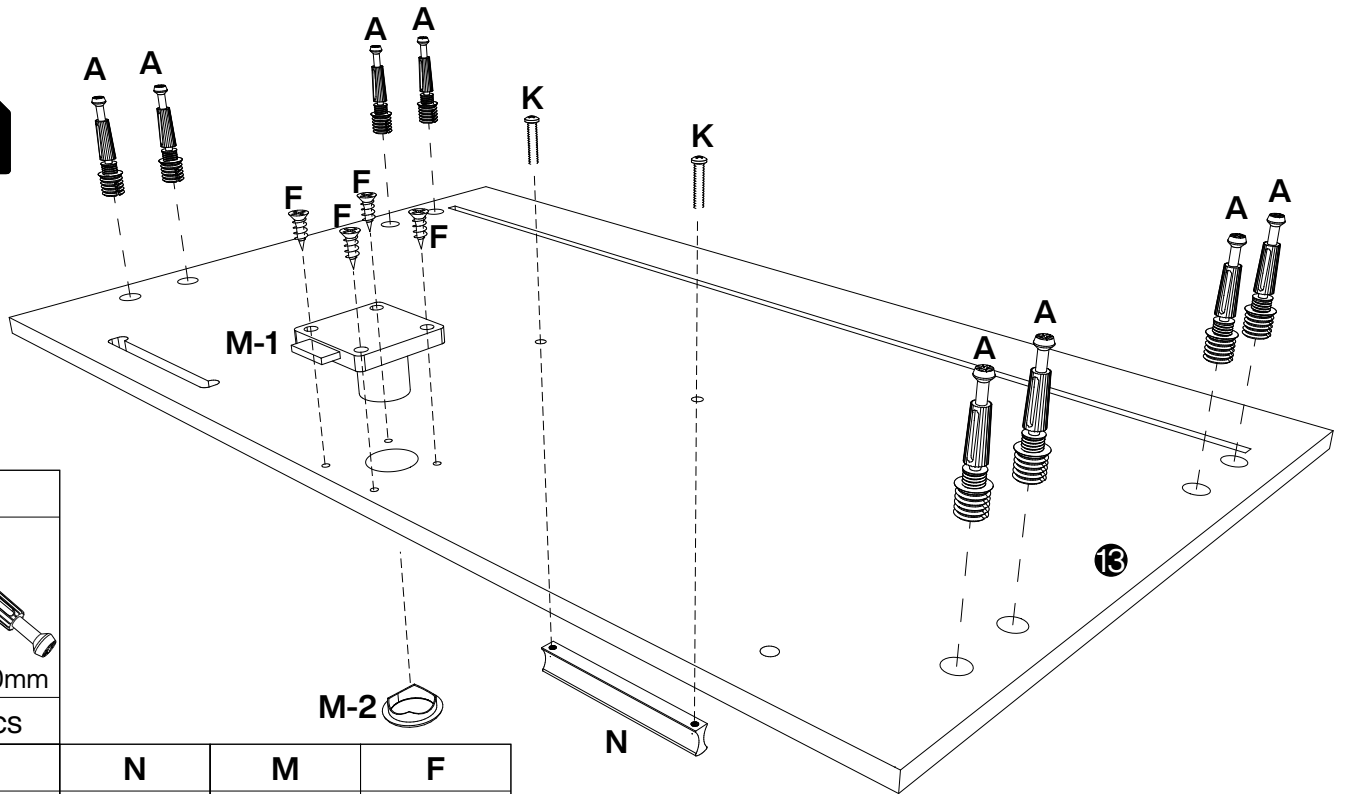
A			
			
M6x40mm			
8 pcs			
K	N	M	F
			
M4x18mm			Ø3x18mm
2 pcs	1 pc	1 pc	4 pcs

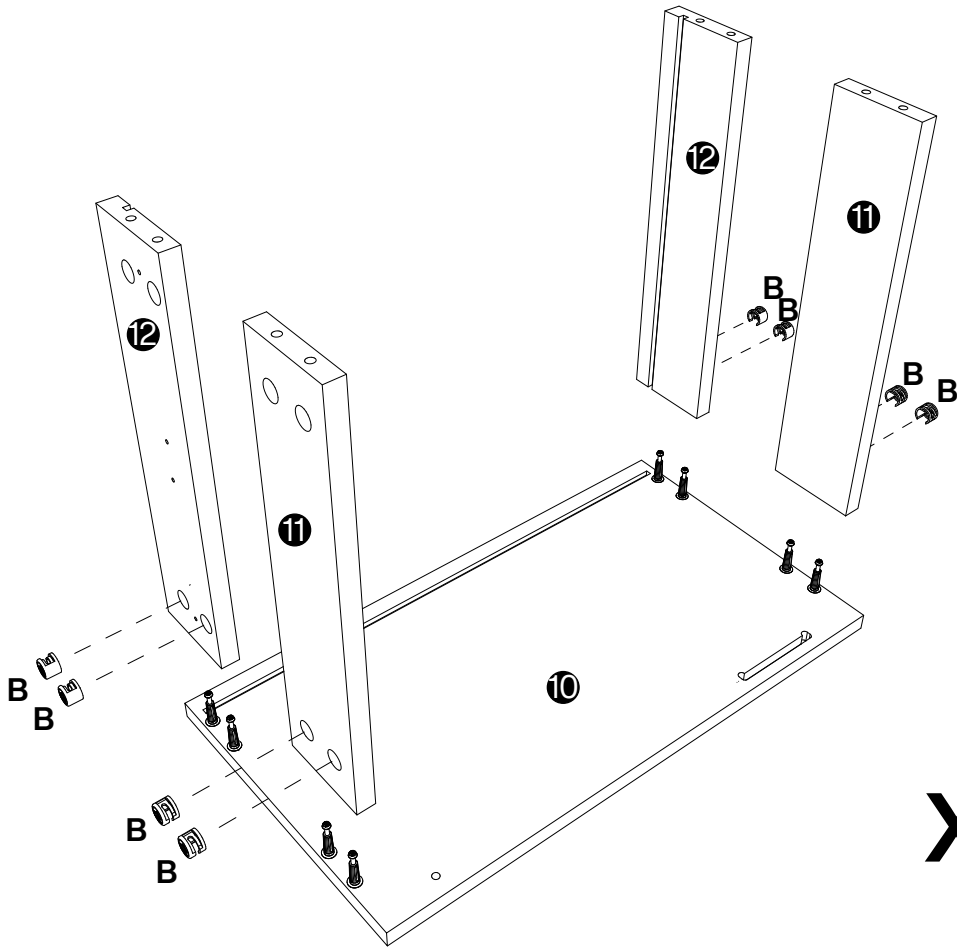

20



B

Ø15x12mm
32 pcs

X4

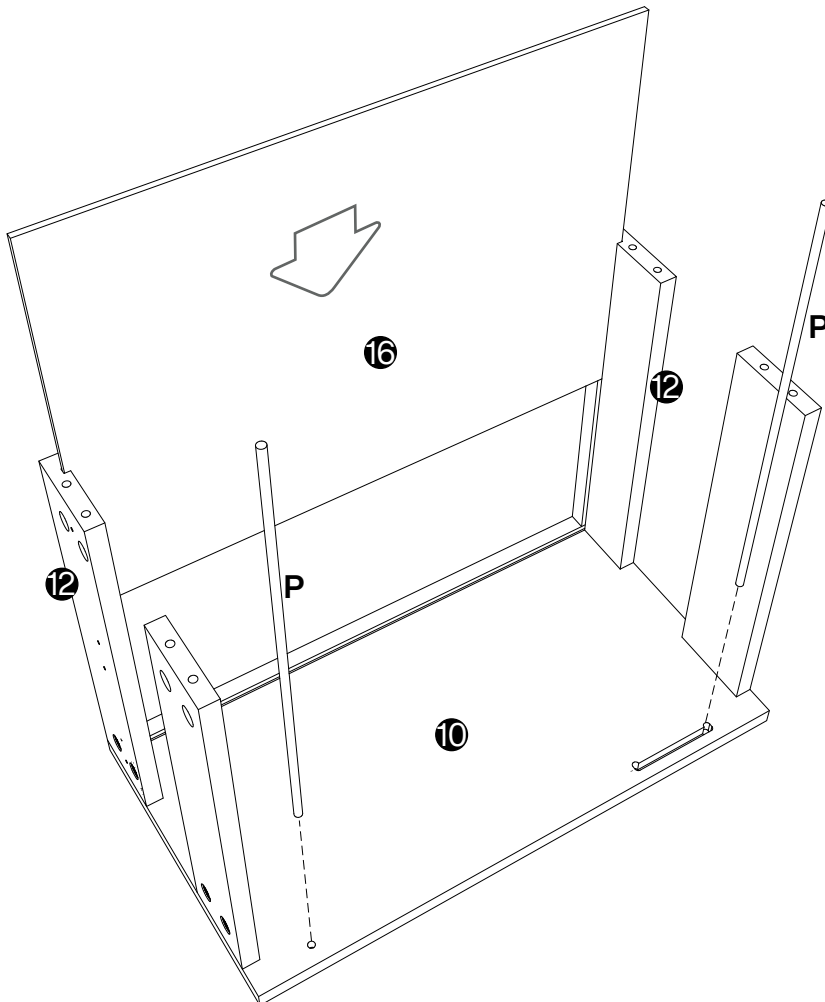
21

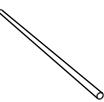

P

8 pcs

X4

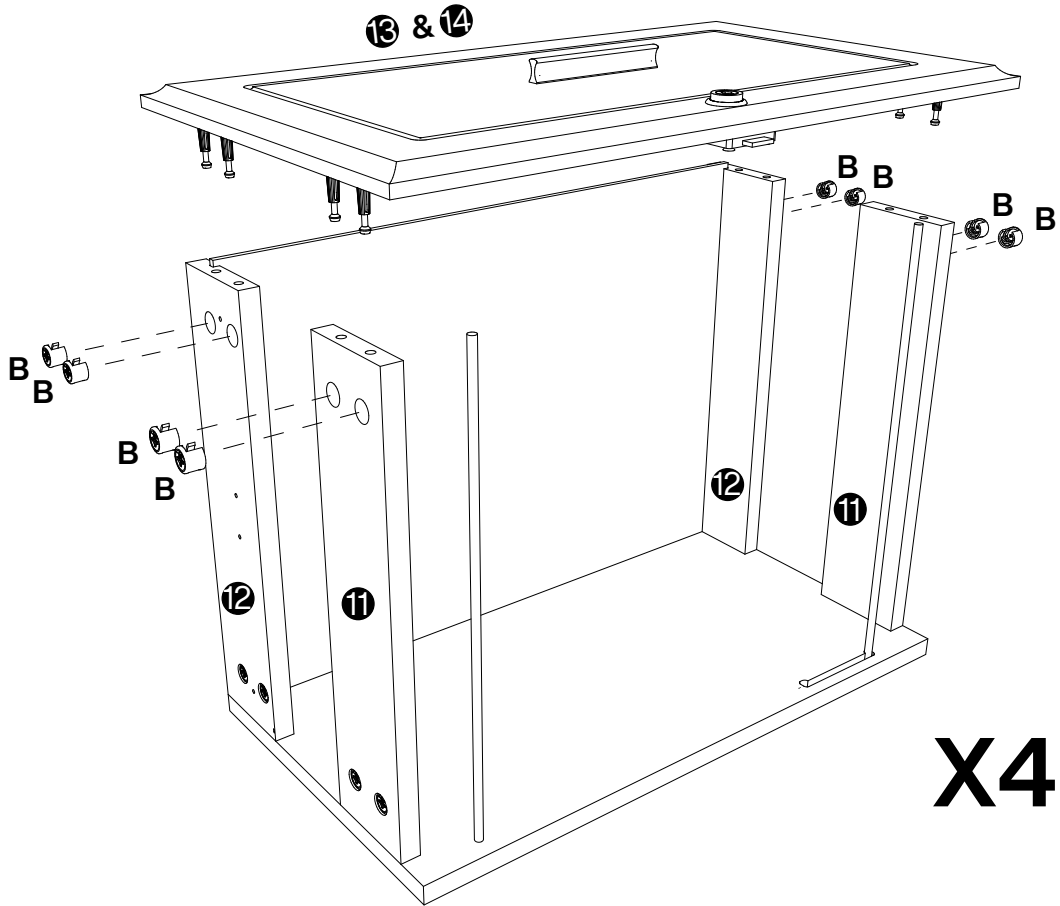
22



B

Ø15x12mm
32 pcs

X4

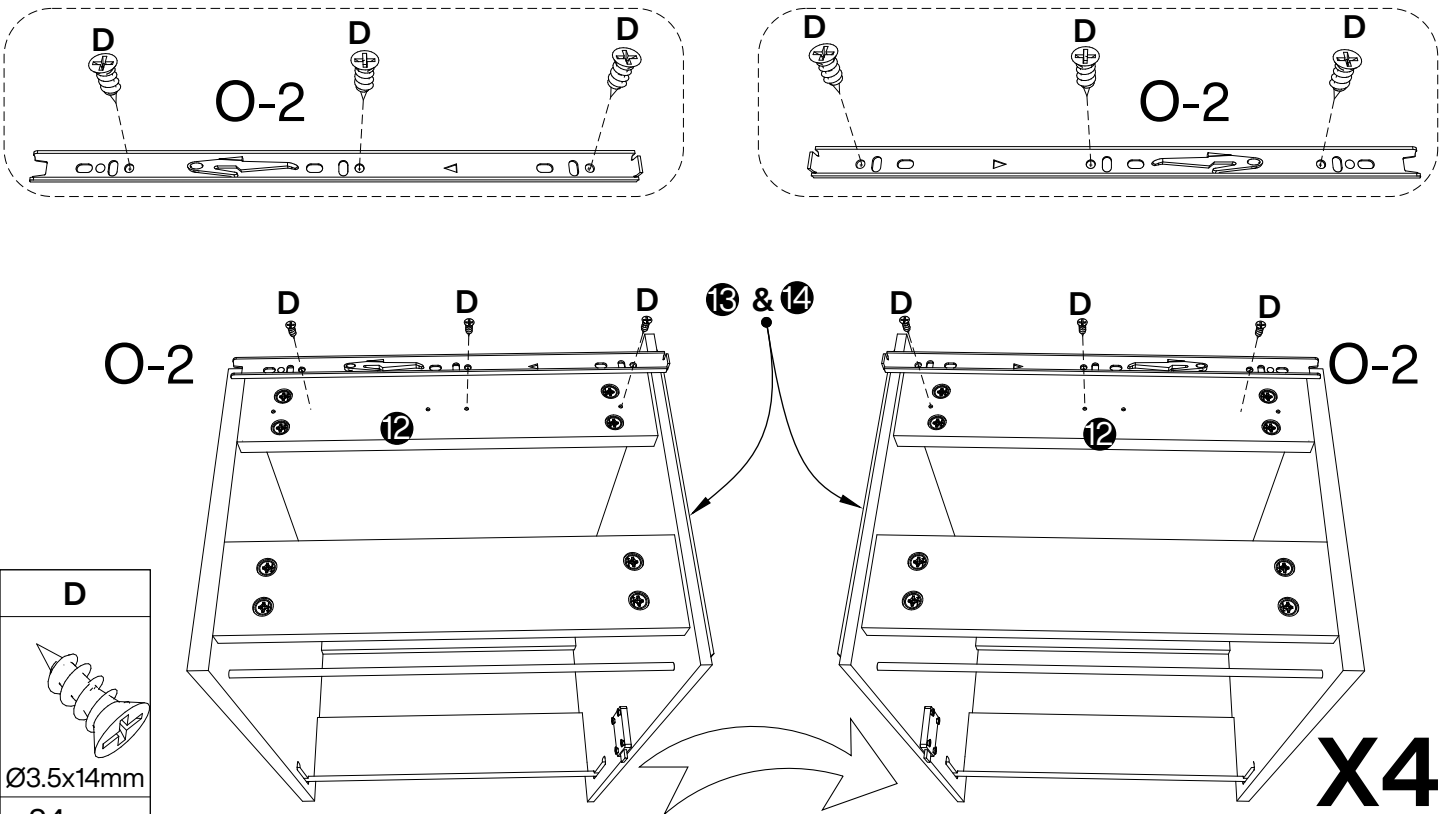
23



D

Ø3.5x14mm
24 pcs

X4

Rotate 180°

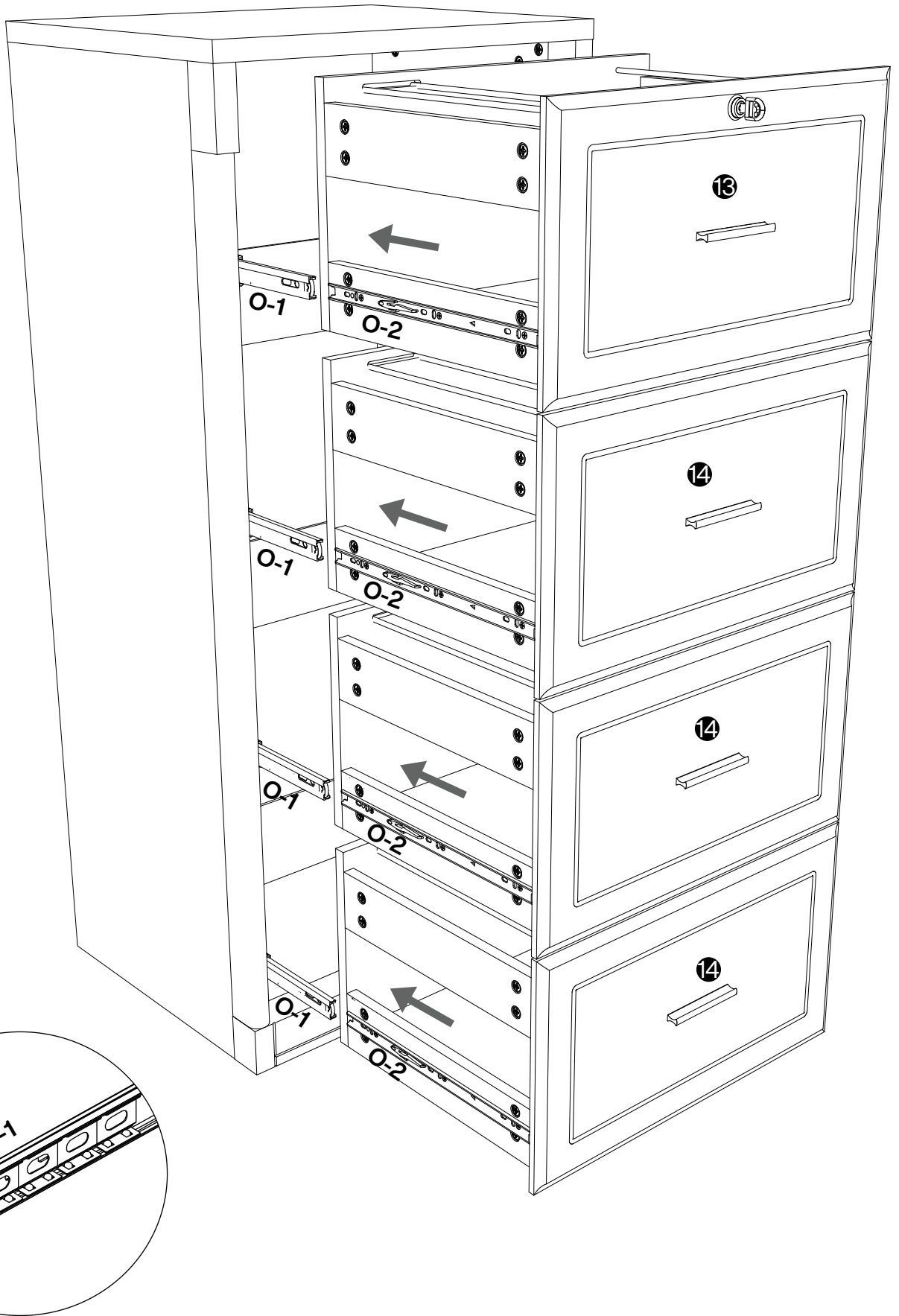
24



Move the movable iron piece with the small iron ball to the front and align the mounting rail.

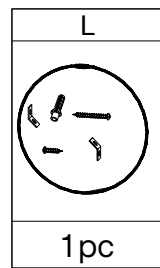

Wall

Step 1

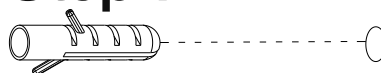

Step 2

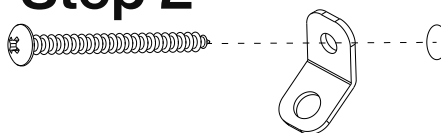

Step 3

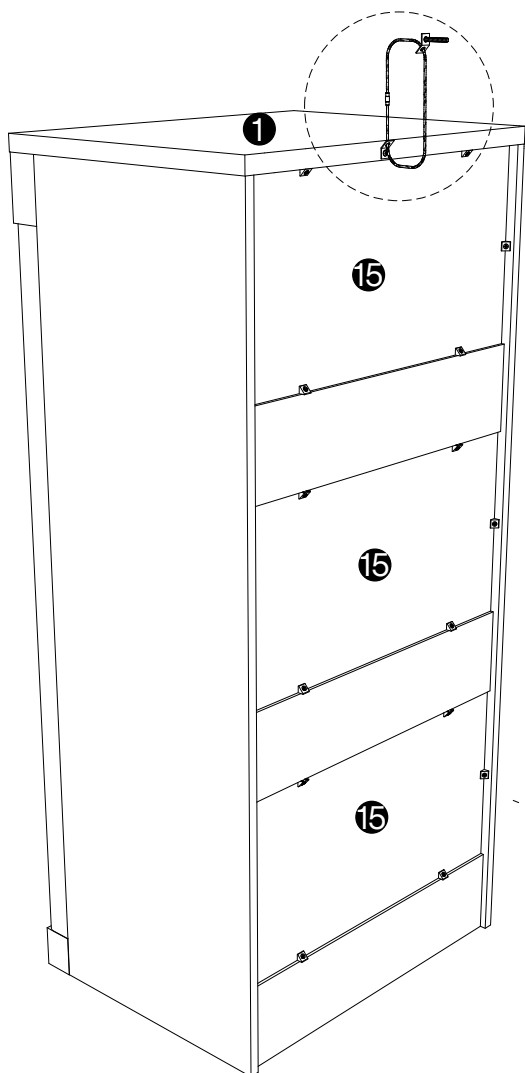
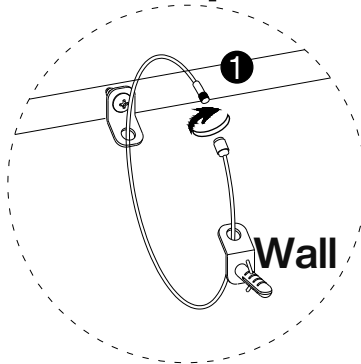

Thank you for your support!

