

Thank you for purchasing. We hope you get years of enjoyment from your new bed. The unique brushing process highlights the woods natural grain. All our wood is plantation grown. No two pieces of wood are the same, enjoy the natural beauty of wood, every piece of wood has unique grain and color and knots, these differences in texture and color create the look only solid wood provides.

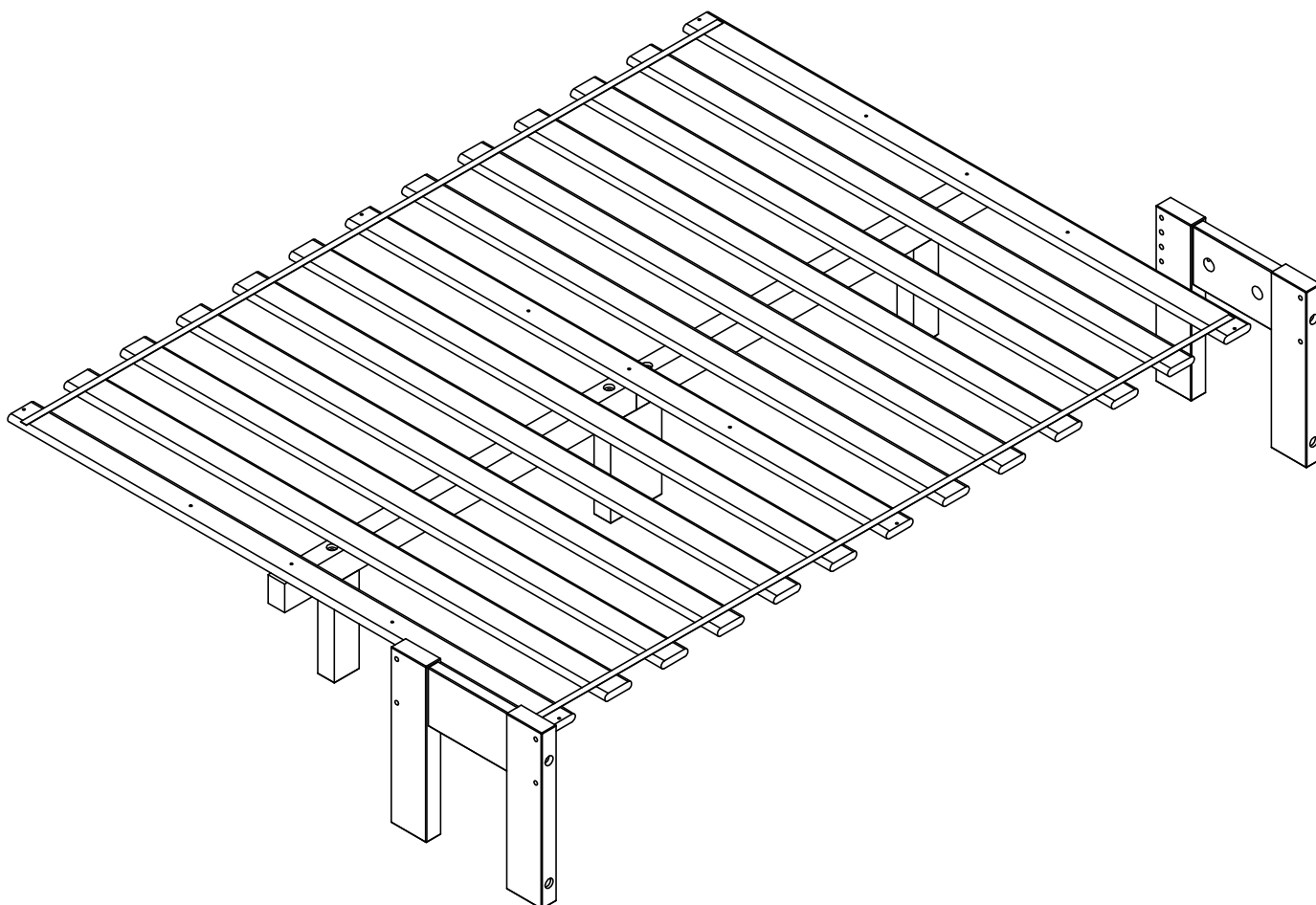

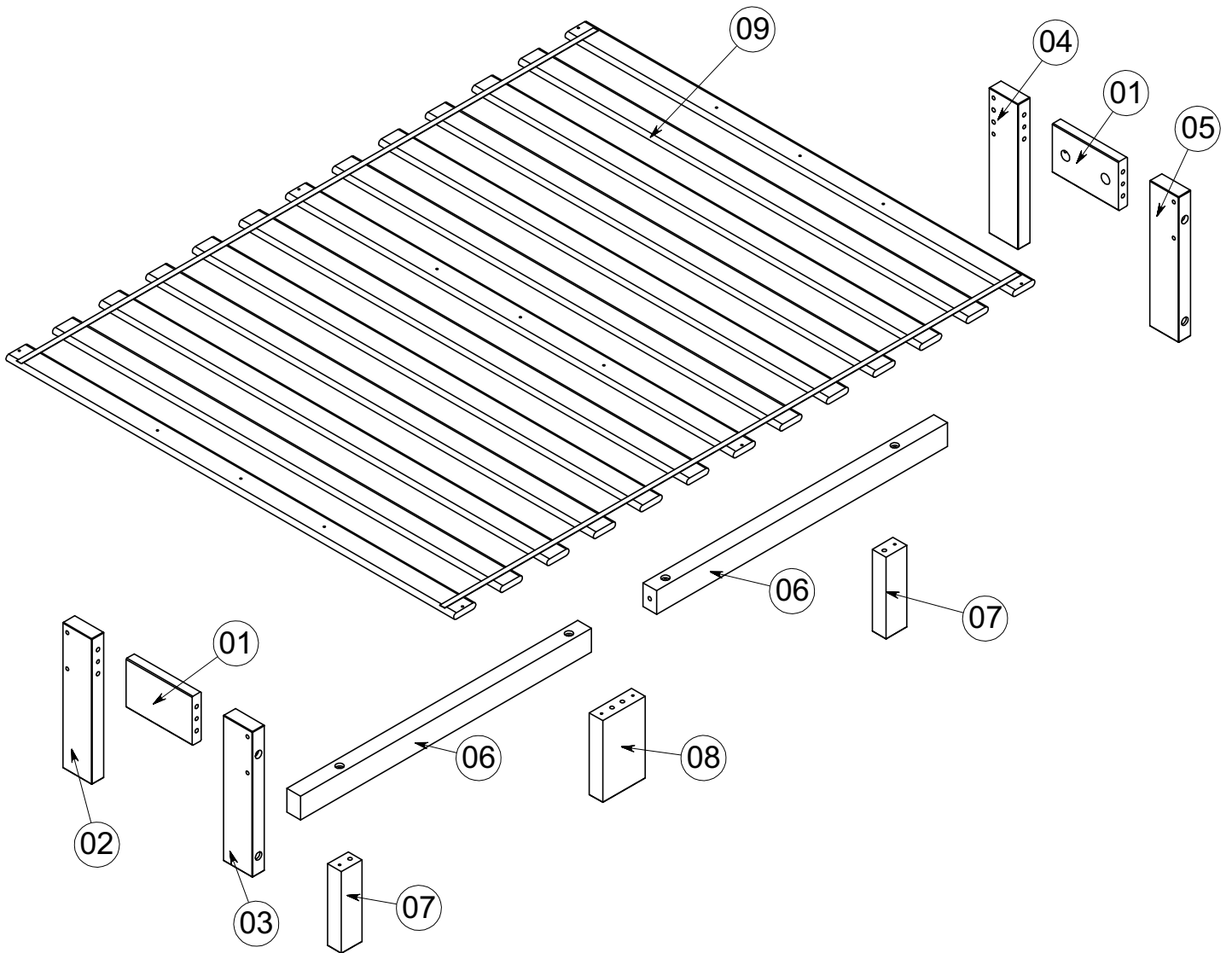

## **FULL CONVERSION KIT**





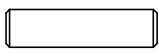

# COMPONENTS

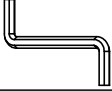

## HARDWARE

<b>A</b>	 10X40	<b>08</b>
<b>B</b>	 (17) 1/4X130	<b>04</b>
<b>D</b>	 (17) 1/4X80	From Bunk
<b>F</b>	 CC 4X35	<b>03</b>
<b>G</b>		<b>04</b>

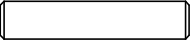
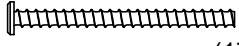
<b>H</b>		<b>02</b>
<b>L</b>	 3/16X30	<b>08</b>
<b>M</b>	 (17) 3/16X12	<b>16</b>
<b>N</b>		<b>02</b>
<b>O</b>	 10X50	<b>05</b>
<b>P</b>	 (17) 7X90	<b>04</b>

# STEP 1

INSERT DOWEL (A,O) TO COMPONENTS SHOWN

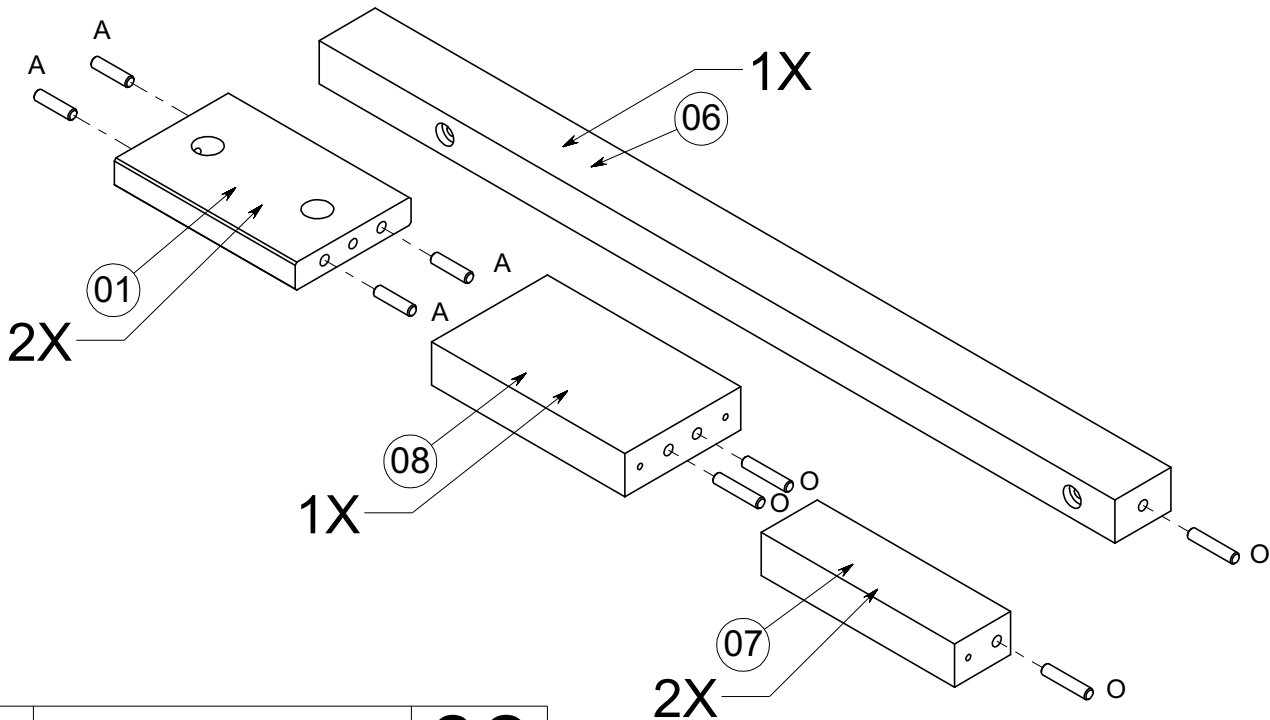

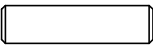
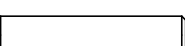
<b>A</b>		10X50	<b>08</b>
<b>O</b>		10X50	<b>05</b>



# STEP 2

INSERT CROSS BOARD (01) TO POSTS (02, 03, & 04, 05)

TIGHTEN CROSS BOARD (01) USING BOLTS (B) & NUTS (G)

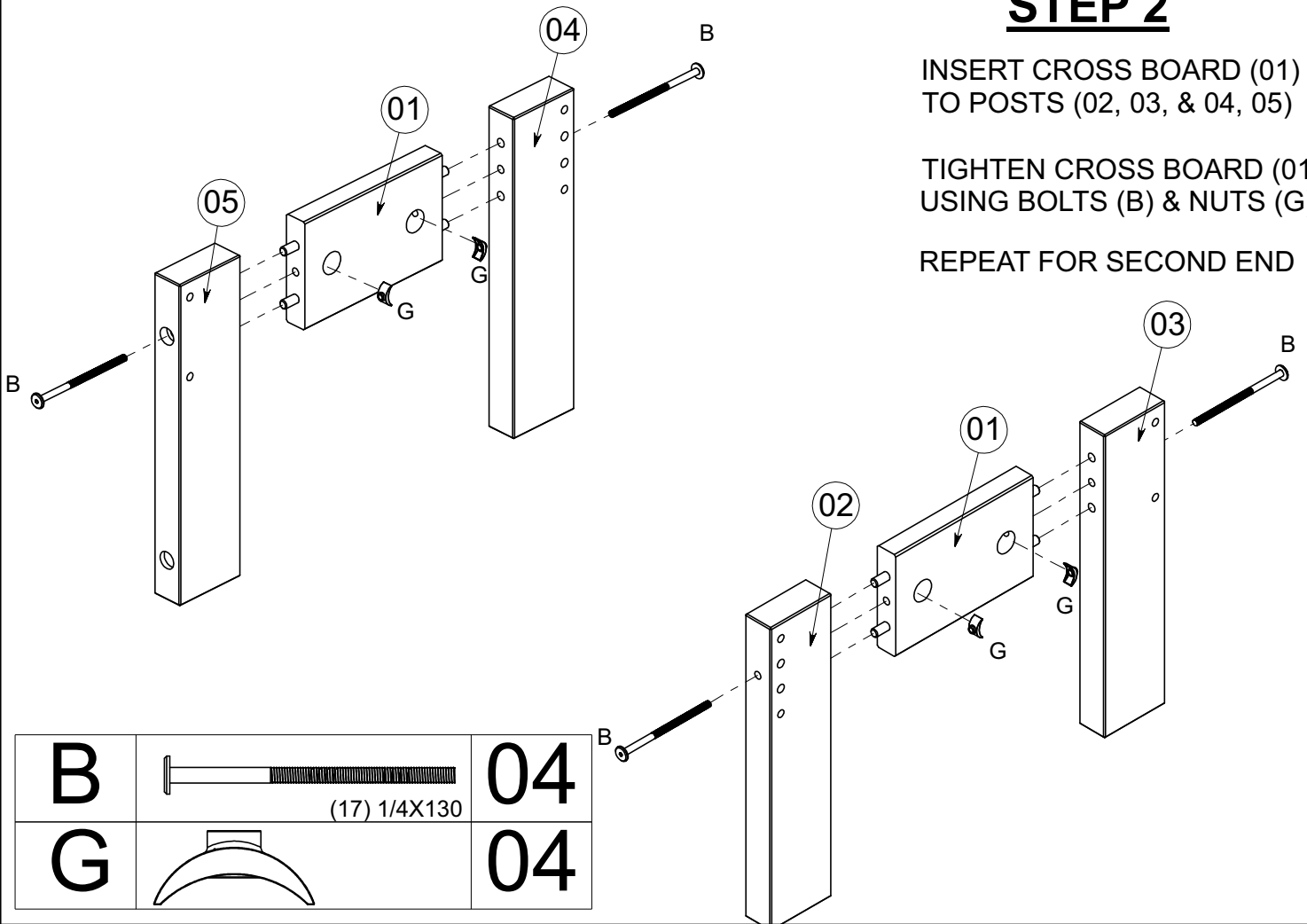
REPEAT FOR SECOND END



<b>B</b>		(17) 1/4X130	<b>04</b>
<b>G</b>			<b>04</b>

### STEP 3

ONLY IF BUNK IS ASSEMBLED  
REMOVE BOTTOM, FRONT  
SIDERAIL.

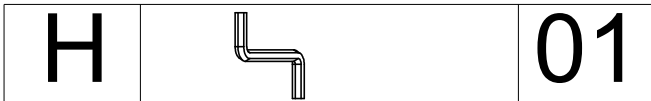
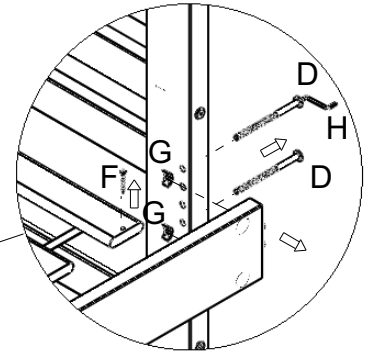
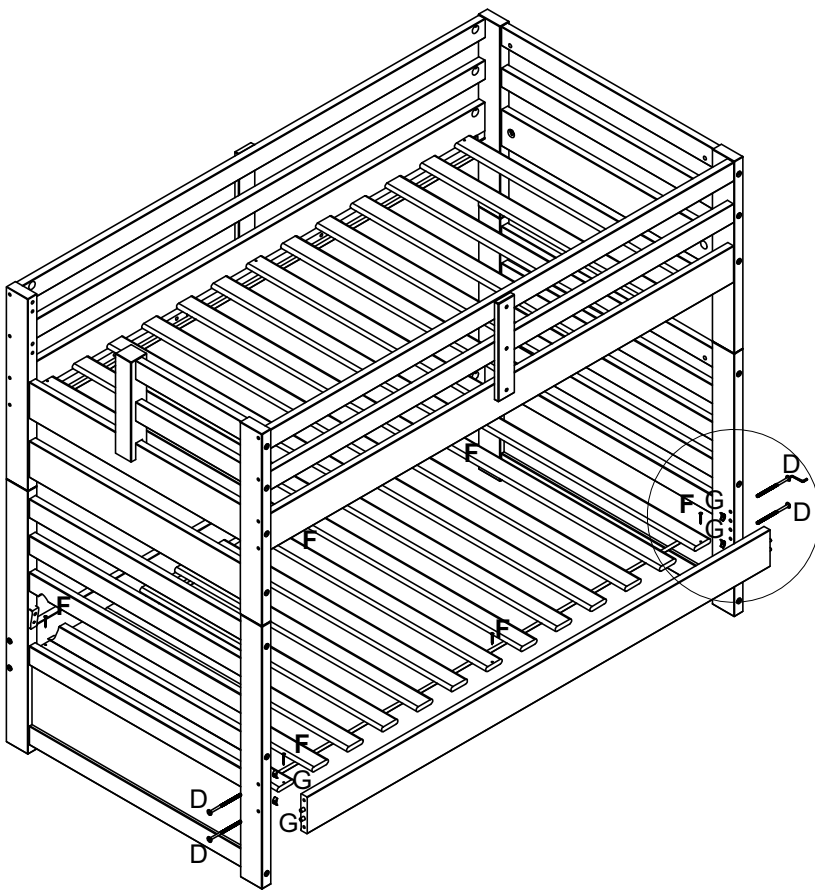

### STEP 4

ATTACH BOTH CENTER BEAMS (06)  
INSERT LEGS (07) TOWARDS THE  
ENDS OF THE BEAM  
THEN INSERT LEG (08) TO THE  
CENTER OF THE BEAM  
TIGHEN LEGS (07, 08) USING  
BOLTS (P)

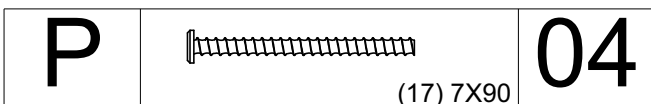
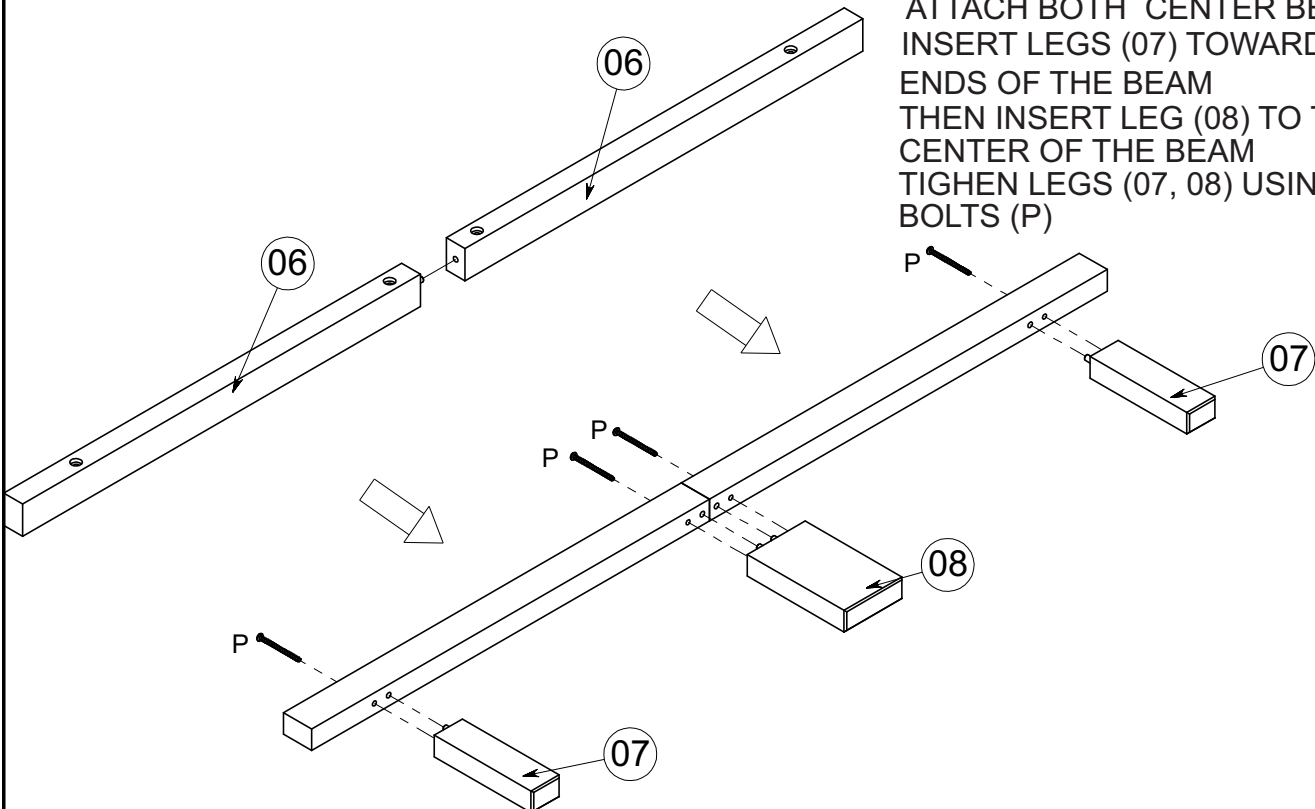

## STEP 5

INSERT SIDERAIL FROM BUNK BED TO THE CONVERSION ENDS (02)  
TIGHTEN SIDERAIL USING  
BOLTS (D) & NUTS (G)

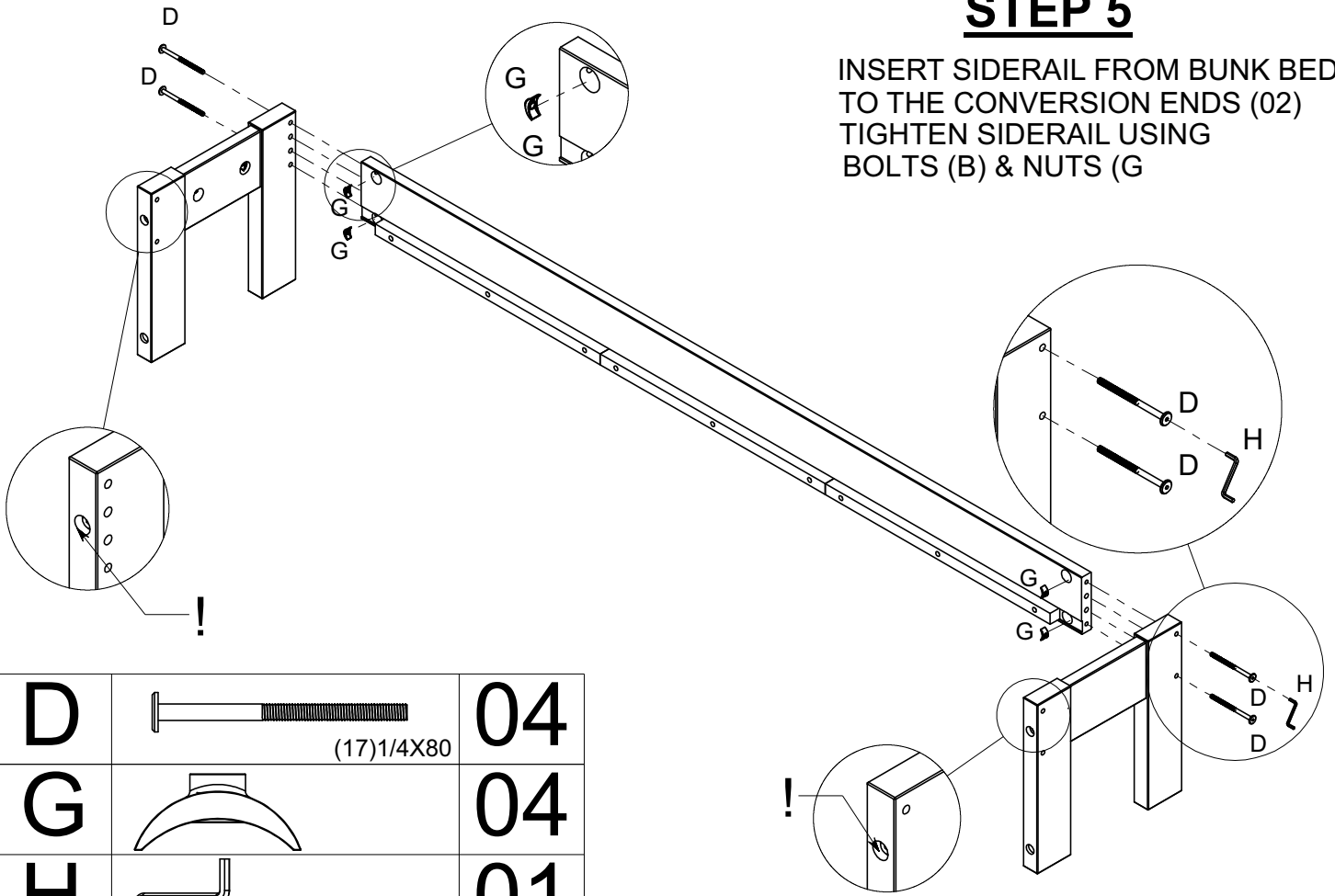

<b>D</b>	(17) 1/4X80	<b>04</b>
<b>G</b>		<b>04</b>
<b>H</b>		<b>01</b>

## STEP 6

ATTACH ASSEMBLY TO BUNK  
USING METAL PLATE (N), THREAD  
RODS (L) & THREAD SLEEVE (M)  
THEN TIGHTEN

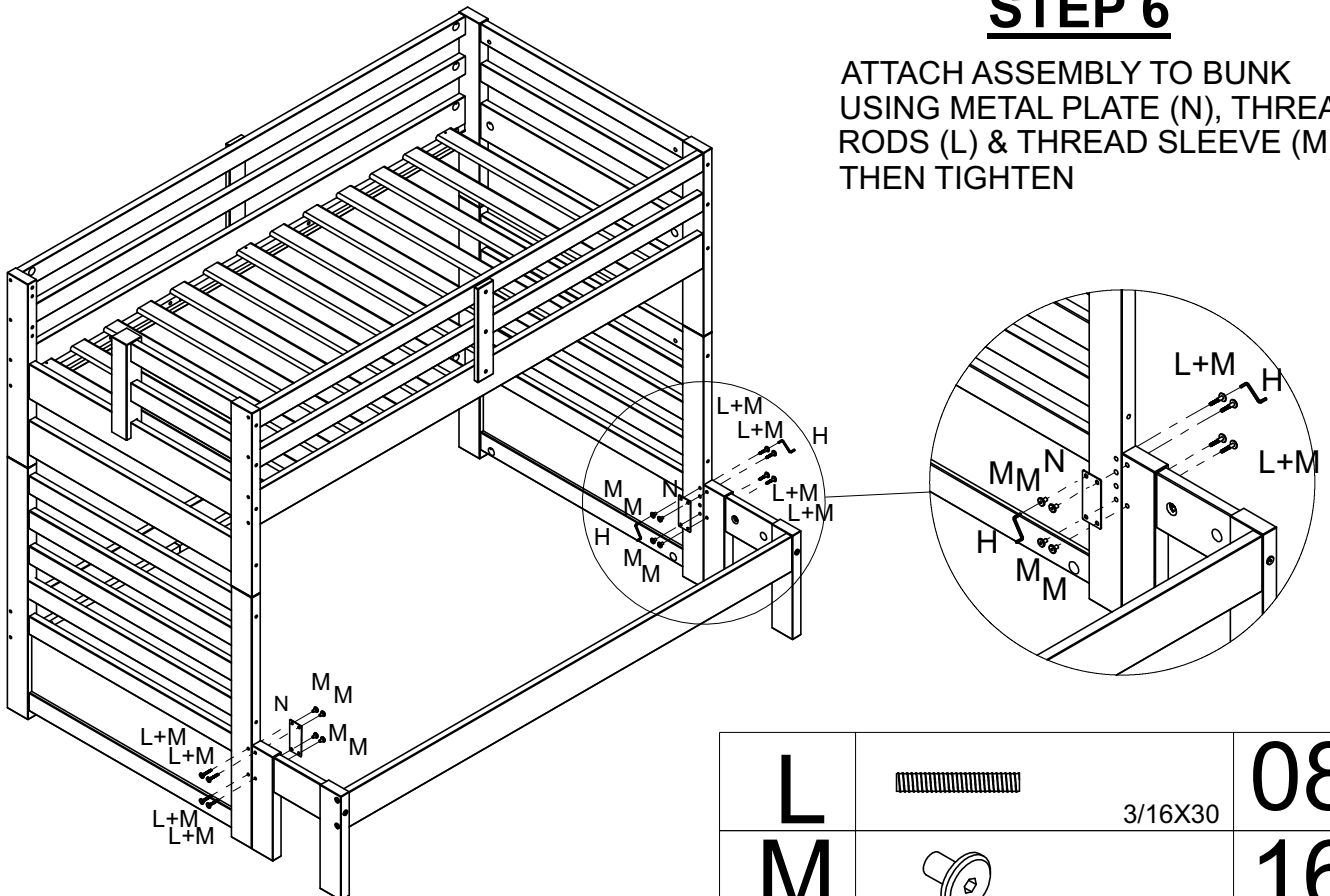

<b>H</b>		<b>02</b>
----------	--	-----------

<b>L</b>	3/16X30	<b>08</b>
<b>M</b>	(17) 3/16X12	<b>16</b>
<b>N</b>		<b>02</b>

## **STEP 7**

PLACE CENTER  
SUPPORT  
INTO MIDDLE OF THE  
BOTTOM BED

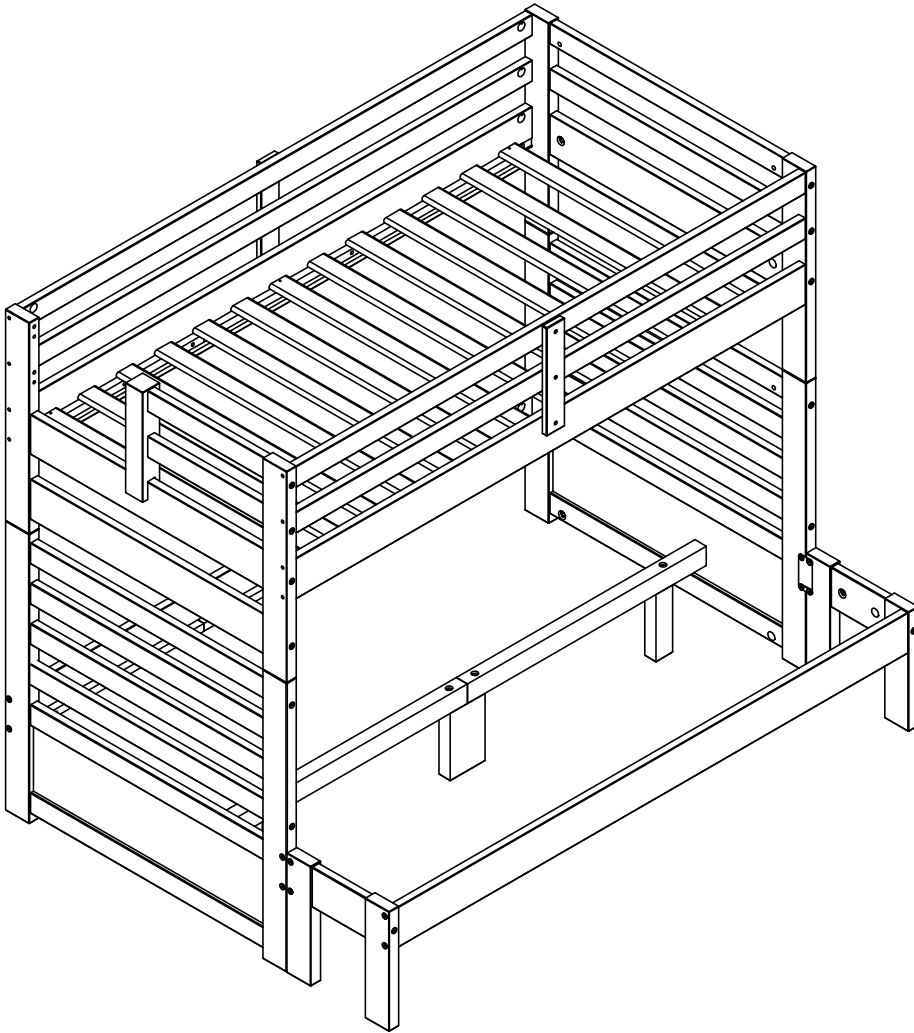

## **STEP 8**

LAY OUT SLAT KIT (09) ON THE  
CLEAT OF SIDERAILS.  
\*\*BE SURE THE END SLATS ARE FLUSH  
WITH THE END OF THE CLEAT.

ATTACH BOTH END SLAT BOARDS  
& MIDDLE SLAT BOARD TO THE CLEAT  
& CENTER SUPPORT WITH  
SCREWS (F)

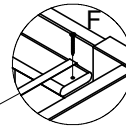
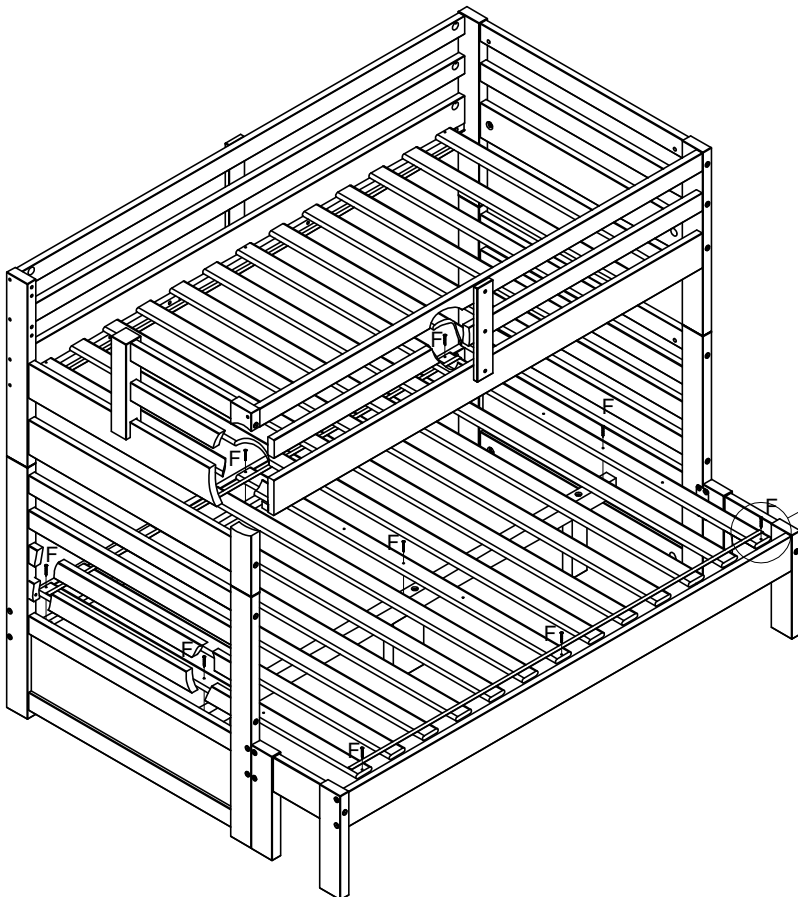

**F**



CC 4X35

**09**